

## Chapter 4

### Roadside Safety

4.1	Clear Zone .....	4-1
4.1.1	Clear Zone Concept.....	4-1
4.1.2	Clear Zone Criteria.....	4-2
4.2	Hazard Standards .....	4-4
4.2.1	Canal Hazards .....	4-4
4.2.2	Drop-off Hazards.....	4-7
4.3	Roadside Barriers .....	4-9
4.3.1	Warrants .....	4-9
4.3.2	Barrier Selection .....	4-10
4.3.3	End Treatments .....	4-10
4.3.4	Transitions .....	4-11
4.3.5	Placement .....	4-11
4.3.6	Upgrading Existing Barrier Systems .....	4-13
	4.3.6.1 Resetting Guardrail .....	4-14
4.4	Median Barriers.....	4-15
4.4.1	Warrants .....	4-15
4.4.2	Selection .....	4-15
4.4.3	End Treatments .....	4-15
4.5	Crash Cushions.....	4-17
4.5.1	Warrants .....	4-17
4.5.2	Selection .....	4-17
4.5.3	Design.....	4-18
4.6	Roadside Appurtenances.....	4-19

4.6.1	Sign Supports .....	4-19
4.6.2	Mailbox Supports .....	4-19
4.6.3	Other Appurtenances.....	4-19
4.6.4	Location Criteria .....	4-19
4.6.5	Bus Benches and Transit Shelters.....	4-19
4.7	Non-Standard Roadside Safety Devices.....	4-20

### Tables

Table 4.3.1	Minimum Offset of Barriers (Measured from the face of the barrier).....	4-12
-------------	---	------

### Figures

Figure 4.1.2.1	Clear Zone Plan View .....	4-2
Figure 4.1.2.2	Clear Zone Cross Section .....	4-3
Figure 4.2.2	Drop-off Hazards in Urban Sections .....	4-7
Figure 4.3.1	Placement of Curb-Guardrail Combinations .....	4-13

### Exhibits

Exhibit 4-A	Minimum Standards for Canal Hazards (Rural and Urban Flush Shoulders) .....	4-5
Exhibit 4-B	Minimum Standards for Canal Hazards (Urban Curb or Curb and Gutter).....	4-6

## Chapter 4

# Roadside Safety

### 4.1 Clear Zone

#### 4.1.1 Clear Zone Concept

A roadside that is traversable and unobstructed by fixed objects will allow vehicles that leave the roadway to recover safely. The clear zone is the relatively flat unobstructed area that is to be provided for safe use by errant vehicles. The designer should provide as much clear zone as practical.

If natural or man-made hazards, including slopes steeper than 1:3, occur within the clear zone, the designer should attempt the following treatments, in order of priority:

1. Eliminate the hazard.
  - a. Remove the hazard.
  - b. Relocate the hazard outside the clear zone.
  - c. Make the hazard traversable or crashworthy.
2. Shield the hazard with a longitudinal barrier or crash cushion. This treatment should only be taken if the barrier or crash cushion presents a lesser hazard.
3. Leave the hazard unshielded. This treatment should be taken only if a barrier or crash cushion is more hazardous than the hazard, if the likelihood of striking the hazard is very small or if the expense of treatment outweighs the benefits in terms of crash reduction.

If crash data or safety reports indicate that early treatment of the hazards will result in fewer or less severe crashes, designers should consider directing that those treatments be accomplished as the first order of work, if feasible and practical.

## 4.1.2 Clear Zone Criteria

The clear zone must be wide enough so that the sum of all the recoverable terrain within is equal to or greater than the recoverable terrain value obtained in the appropriate **Table 2.11.11**, **Table 21.5** or **Table 25.4.14.1**. The process for determining the clear zone width is to extend the clear zone width as shown in **Figure 4.1.2.1** and **4.1.2.2** until the recoverable terrain is obtained. If non-recoverable terrain is encountered before obtaining the full amount of recoverable terrain, then the remaining amount must be provided beyond the non-recoverable terrain. Where right of way permits, the portion of recoverable terrain provided beyond the non-recoverable terrain must be a minimum of 10 feet. The clear zone is to be free of hazardous objects, hazardous terrain, and non-traversable terrain. Also, clear zones may be widened based on crash history.

Figure 4.1.2.1 Clear Zone Plan View

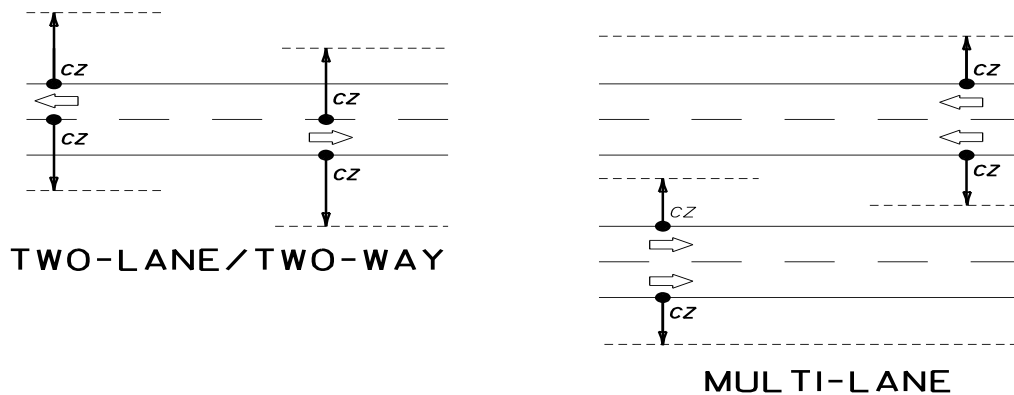

**Figure 4.1.2.2 Clear Zone Cross Section**

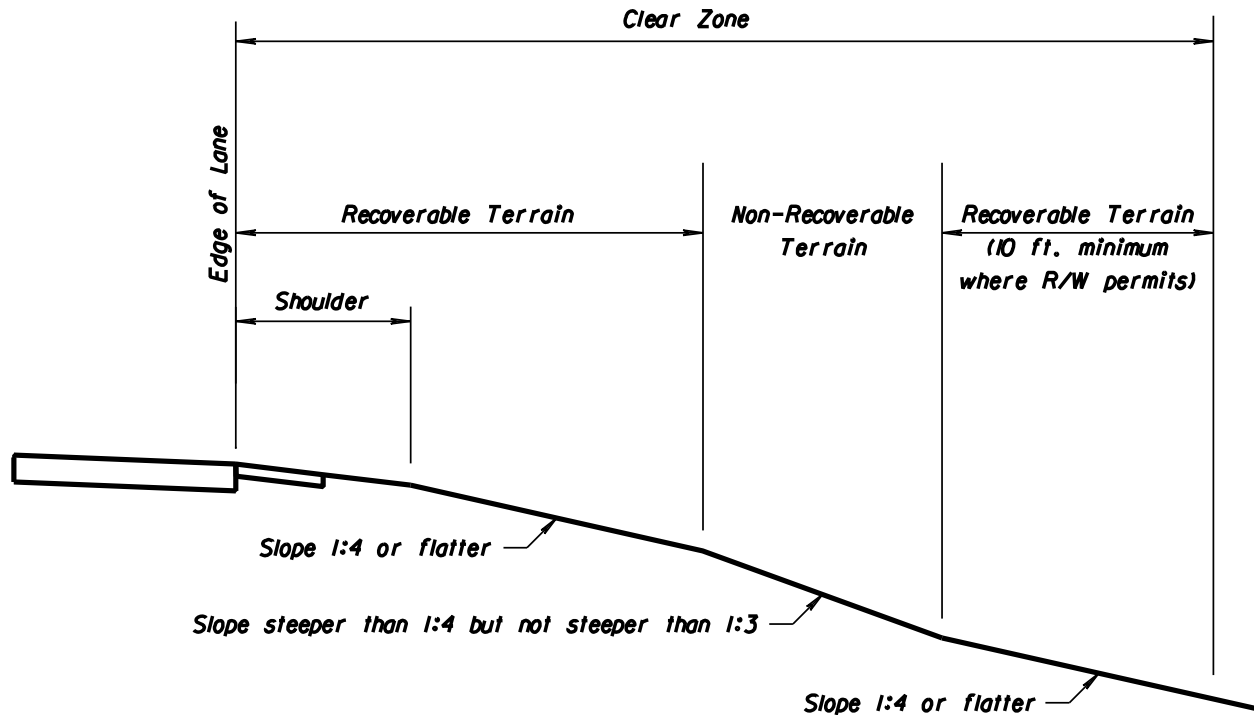

Note: See **Chapter 2, Table 2.4.1** for new construction slope criteria.

See **Chapter 25, Section 25.4.9** for RRR slope criteria.

Roadside Terrain includes all surfaces along the roadway other than Travel Lanes, Auxiliary Lanes, and Ramps. For the purpose of establishing Clear Zones, Roadside Terrain is defined as recoverable, non-recoverable, non-traversable, and hazardous as follows:

1. Recoverable when it is safely traversable and on a slope that is 1:4 or flatter.
2. Non-recoverable when it is safely traversable and on a slope that is steeper than 1:4 but not steeper than 1:3.
3. Non-traversable when it is not safely traversable or on a slope that is steeper than 1:3.
4. Hazardous when a slope is steeper than 1:3 and deeper than 6 feet.

## 4.2 Hazard Standards

### 4.2.1 Canal Hazards

A canal is defined as an open ditch parallel to the roadway for a minimum distance of 1000 ft. and with a seasonal water depth in excess of 3 ft. for extended periods of time (24 hours or more).

For rural and urban flush shoulder highways, the distance from the outside edge of the through travel lane to the top of the canal side slope nearest the road will be no less than 60 ft. for highways with design speeds of 50 mph or greater. For highways with design speeds less than 50 mph this minimum distance may be reduced to 50 ft. for rural and urban flush shoulder highways or 40 ft. for urban curb or curb and gutter highways. When new canal or roadway alignment is required, distances greater than those above should be provided, if possible, to accommodate possible future improvements to the roadway (widening, etc.).

On fill sections, a flat berm (maximum 1:10 slope) of width no less than 20 ft. will be provided between the toe of the roadway front slope and the top of the canal side slope nearest the roadway. This minimum berm width applies to all types of highways, both rural and urban construction. (See **Exhibits 4-A & 4-B**)

When the slope between the roadway and the "extended period of time" water surface is 1:6 or flatter, the minimum distance can be measured from the edge of the through lane to the "extended period of time" water surface and a berm is not required.

In sections with ditch cuts, 20 ft. will be provided between the toe of the front slope and the top of the canal.

Guardrail or other protective devices shall be installed 5 ft. from the canal front slope where it is not possible to meet the above minimum criteria. The design is complicated when clear zone and slope criteria are combined with canal hazard criteria. Extreme caution must be taken to ensure that all criteria are met.

If the minimum standards for canal hazards cannot be met, then the standard guardrail treatments as provided in the **Design Standards** should be used.

### Exhibit 4-A Minimum Standards for Canal Hazards (Rural and Urban Flush Shoulders)

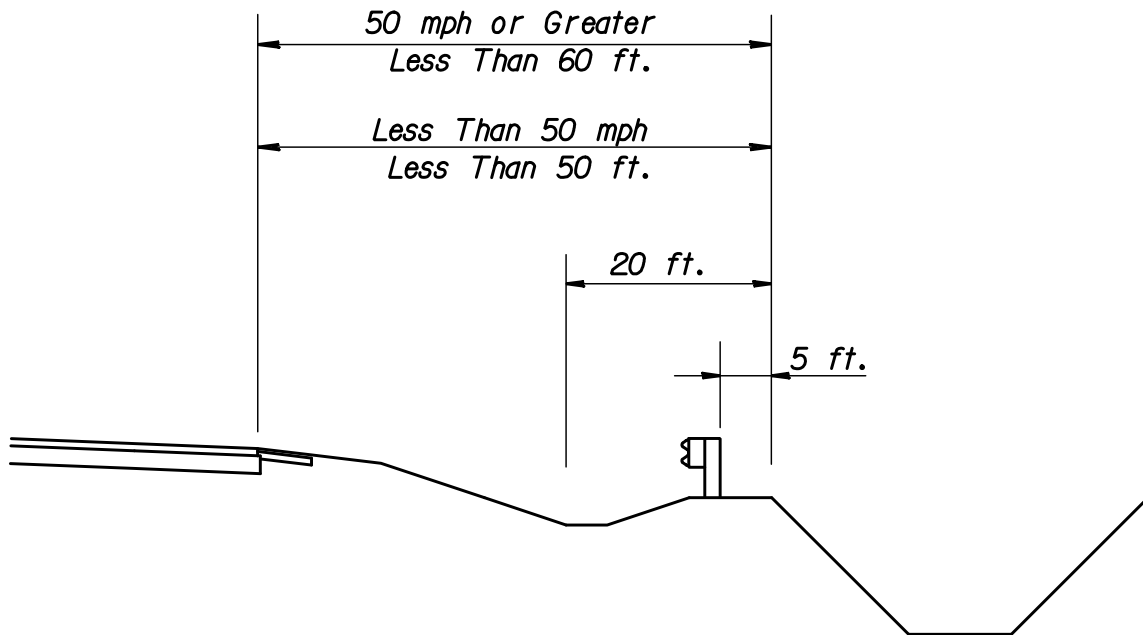
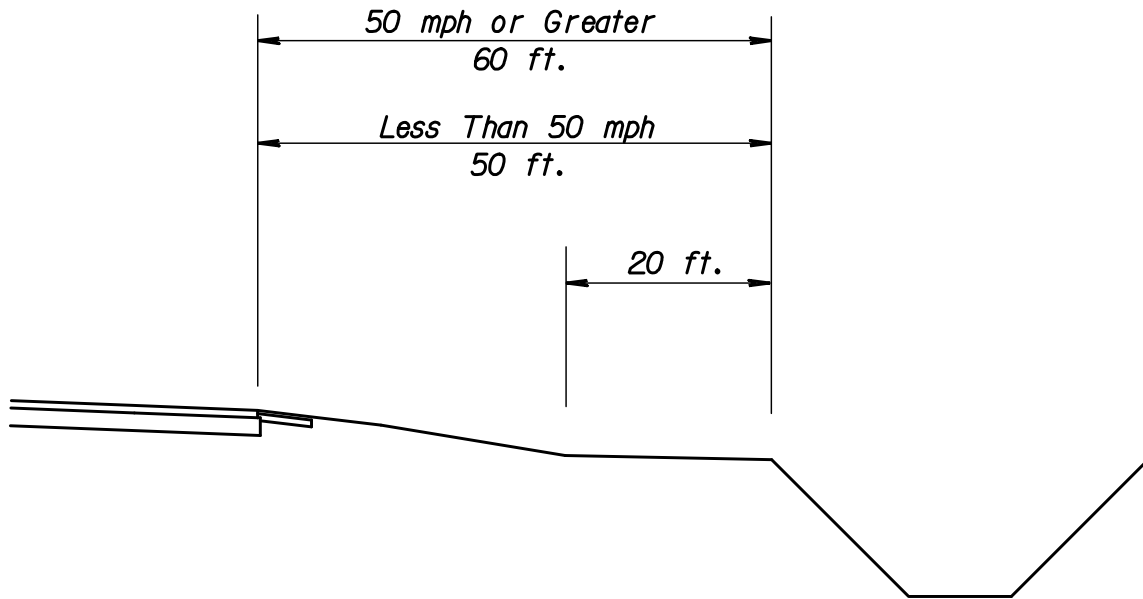

**Exhibit 4-B Minimum Standards for Canal Hazards  
(Urban Curb or Curb and Gutter)**

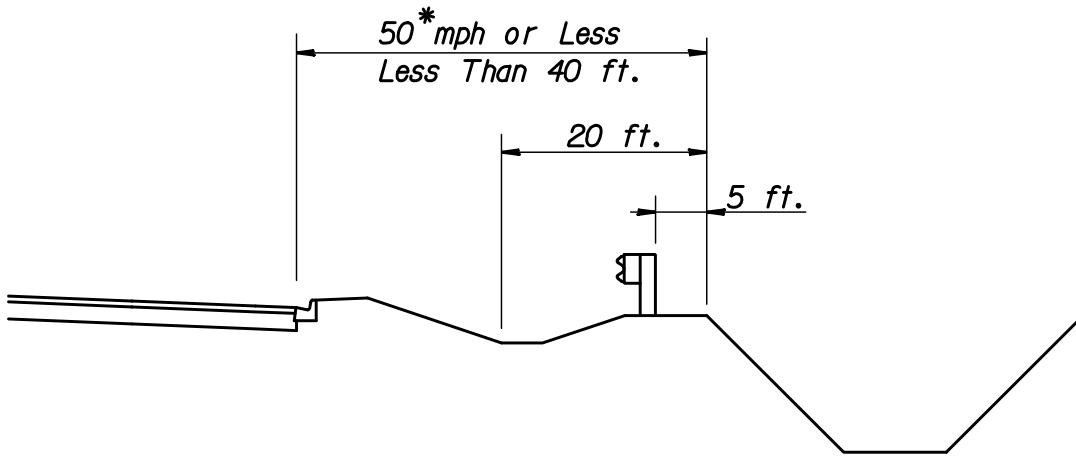
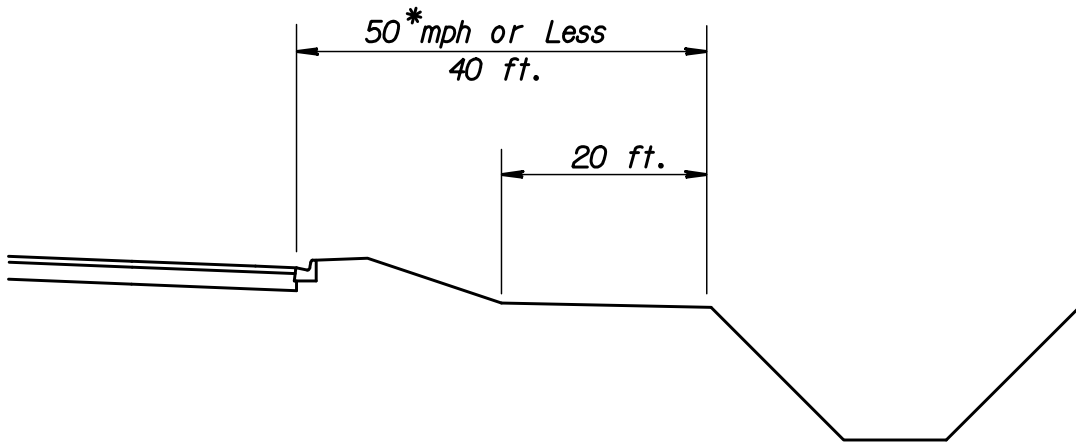

\* Posted speeds not to be greater than 45 mph.



## 4.2.2 Drop-off Hazards

Drop-off hazards are defined as steep or abrupt downward slopes that can be perilous to vehicle occupants and/or pedestrians and cyclists. The Engineer should consider shielding any drop-off determined to be a hazard. The following guidelines will be useful in standardizing the identification and treatment of drop-off hazards.

Drop-off hazards for vehicle occupants:

- 1 A drop-off of 6 feet or more with a slope steeper than 1:3 should be considered a hazard and shielded when it is within the Clear Zone.
- 2 In urban sections with curb or curb and gutter, a drop-off of 6 feet or greater with a slope steeper than 1:3 located within 22 feet of the traveled way, should be evaluated for shielding.

**Figure 4.2.2 Drop-off Hazards in Urban Sections**

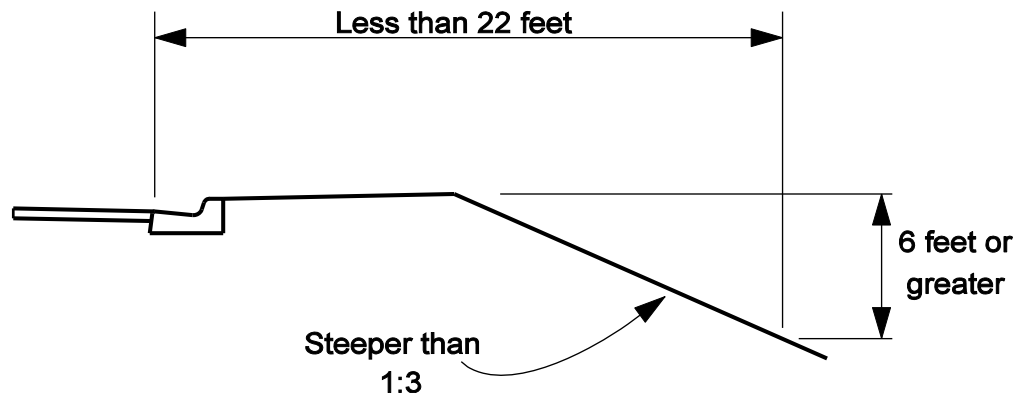

In determining if shielding a drop-off hazard would be feasible for protecting vehicle occupants, the following should be considered:

1. When a drop-off is shielded, a guardrail or barrier is usually set closer to the road, which increases the probability of impacting the guardrail or barrier. These shields generally require the ends to be treated, which also needs to be taken into consideration. Refer to **Section 23.5** of this volume for guidance on evaluating the benefits of shielding a drop-off.

2. When a drop-off is to be shielded with guardrail, a minimum of 62.5 feet of guardrail is required to develop proper ribbon strength. A minimum clear area 4 feet wide is to be provided behind the guardrail to allow the guardrail to deflect when impacted. Proper slope and soil bearing for the posts is to be provided.
3. Another consideration is whether the drop-off has a significant crash history. Drop-offs that have had 3 crashes within three consecutive years over a five-year period are considered to have a significant crash history and should be shielded. Five years of crash data for a particular site can be obtained from the Safety Office.

For drop-off criteria in work zones see **Chapter 10** of this volume and **Index 600** of the **Design Standards**.

Generally, pedestrians and bicyclists will be adequately protected from a drop-off hazard if a guardrail or barrier has been installed between the path or sidewalk and the drop-off. However, circumstances do exist that will ultimately dictate when a handrail is needed. For guidance, see **Section 8.8 Drop-off Hazards for Pedestrians and Bicyclists** of this volume.

## 4.3 Roadside Barriers

### 4.3.1 Warrants

Roadside barriers are warranted when hazards exist within the clear zone, hazards cannot be cost effectively eliminated or corrected, and collisions with the hazards will be more serious than collisions with the barriers.

The length of advancement and length of need necessary to properly shield the hazard must be determined on an installation by installation basis as indicated in the ***Design Standards***.

The following conditions within the clear zone are normally considered more hazardous than a roadside barrier:

1. Fill slopes steeper than 1:3.
2. Bridge piers, abutments and railing ends.
3. Non-traversable culverts, pipes and headwalls.
4. Non-traversable parallel or perpendicular ditches and canals.
5. Bodies of water other than parallel ditches and canals that the engineer determines to be hazardous.
6. Parallel retaining walls with protrusions or other potential snagging features.
7. Retaining walls at an approach angle with the edge of pavement larger than 7 degrees (1:8).
8. Non-breakaway sign or luminaire supports.
9. Trees greater than 4 inches in diameter measured 6 inches above the ground at maturity.
10. Utility poles.
11. Rigid protrusions above the ground in excess of 4 inches in height.

In addition to the above hazards, there may be other situations that warrant barrier consideration, such as nearby pedestrian or bicycle facilities, schools, residences or businesses.

## 4.3.2 Barrier Selection

Acceptable standard roadside barriers are detailed in the *Design Standards*. They include:

1. Blocked-out W-beam (strong post).
2. Blocked-out thrie-beam (strong post).
3. Modified thrie-beam (strong post).
4. Concrete barrier wall.

Most guardrail installations will be blocked-out W-beam on wood or steel posts. The thrie-beam guardrail should be considered when additional rail depth is needed because of a potential to under-ride the rail or because additional height may be needed. Other barrier designs may be required by specific site conditions. These must be called for and detailed on a project-by-project basis.

## 4.3.3 End Treatments

Longitudinal barrier ends which are not crashworthy can present serious hazards if they terminate within the clear zone. The Department's crashworthy end treatments and application criteria are detailed in the *Design Standards*. Other end treatments may be required under special circumstances. Special details will be required in the plans, when this is the case.

1. It is very important that the flare with offset be provided exactly as shown in the *Design Standards*. The end offset should be measured off a projection of the face of guardrail alignment. The maximum allowable cross slope in front of the rail is 1:10, including the area in front of and the upstream approach to the end anchorage assembly.
2. Non-crashworthy end treatments will be used outside the clear zone, and at downstream terminations, which are outside the clear zone of the opposing traffic flow. The Type II end anchorage is non-crashworthy and, therefore, may **NOT** be used as an approach terminal end treatment unless other end shielding is provided.
3. Thrie-beam and concrete barrier wall will be terminated as shown in the *Design Standards*.

## 4.3.4 Transitions

Whenever standard W-beam or thrie-beam guardrail transitions into bridge rail or concrete barrier wall, a transition section is necessary. Transitions must include sound structural connections, nested beams and additional posts for increased stiffness, as shown in the **Design Standards**. Standard flares should be introduced upstream of the transition section. Care must be taken in the details of the junction of the two barrier types to avoid snag points.

## 4.3.5 Placement

The primary design factors associated with guardrail placement are:

1. Lateral offset from the edge of pavement
2. Terrain effects
3. Flare rate
4. Length of advancement
5. Length of need

The standard offset is the shoulder width plus 2 ft., not to exceed 12 feet. Alternate guardrail offset locations are shown in the **Design Standards**.

A 2 ft. distance from the back of the barrier posts to the shoulder line or slope break is desirable for post support.

The length of advancement is dependent on the design speed, the offset distance to the face of guardrail and the lesser distance (a) to the back of the hazard or (b) to the clear zone needed. The designer must establish this advancement need for all installations on the project. On all facilities the guardrail needs must consider traffic from both directions.

A barrier should not be located so close to the hazard that it is shielding that the hazard is within the dynamic deflection distance of the barrier. The dynamic deflection of standard barriers is shown in **Table 4.3.1**.

**Table 4.3.1 Minimum Offset of Barriers  
 (Measured from the face of the barrier)**

BARRIER TYPE	OFFSET (ft.)
W-Beam with Post Spacing @ 6'-3"	4.0
W-Beam with Post Spacing @ 3'-1½"	3.0
Thrie-Beam with Post Spacing @ 6'-3"	3.3
Thrie-Beam with Post Spacing @ 3'-1½"	2.6
Barrier Wall	0*
Double W-Beams (Nested) with Post Spacing @ 3'-1½"	2.6
Double W-Beams (Nested) with Post Spacing @ 1'-6¾"	2.3
Double Thrie-Beams (Nested) with Post Spacing @ 3'-1½"	2.3
Double Thrie-Beams (Nested) with Post Spacing @ 1'-6¾ "	2.0

\* Except where specifically provided for in the Design Standards, hazards that extend above the top of a barrier wall shall be offset a minimum 1.5' from the face of the top edge of F-shape barrier, and a minimum 2.0' from the face of vertical shape barrier.

**NCHRP Report 537** titled "**Recommended Guidelines for Curb and Curb-Barrier Installations**" provides acceptable placement of curb-guardrail combinations as a function of the lateral offset from the guardrail and the operating speed of the roadway. The application of these guidelines for use on FDOT roadways is contained in the design chart shown in **Figure 4.3.1**.

As shown in the design chart, there is a region between 0 and 8.2 ft behind the face of the curb where guardrail should not be located. For the general case of vehicles leaving the roadway with a broad range of speeds and angles, the bumper is likely to be too high for acceptable guardrail performance in this region. In addition, higher speeds create more suspension system disturbance and; therefore, require more time and distance for the bumper to return to the correct position.

The standard single W-beam guardrail installation (**Design Standards, Index 400**) was tested in this study. Other rails and barrier types (thrie beam, vertical face barrier wall, etc.) were not tested, however may be considered in areas where the W-beam is not considered acceptable.

Barriers should not be placed on slopes steeper than 1:10. This is particularly important for barrier ends shielded by crashworthy devices.

**Figure 4.3.1 Placement of Curb-Guardrail Combinations**

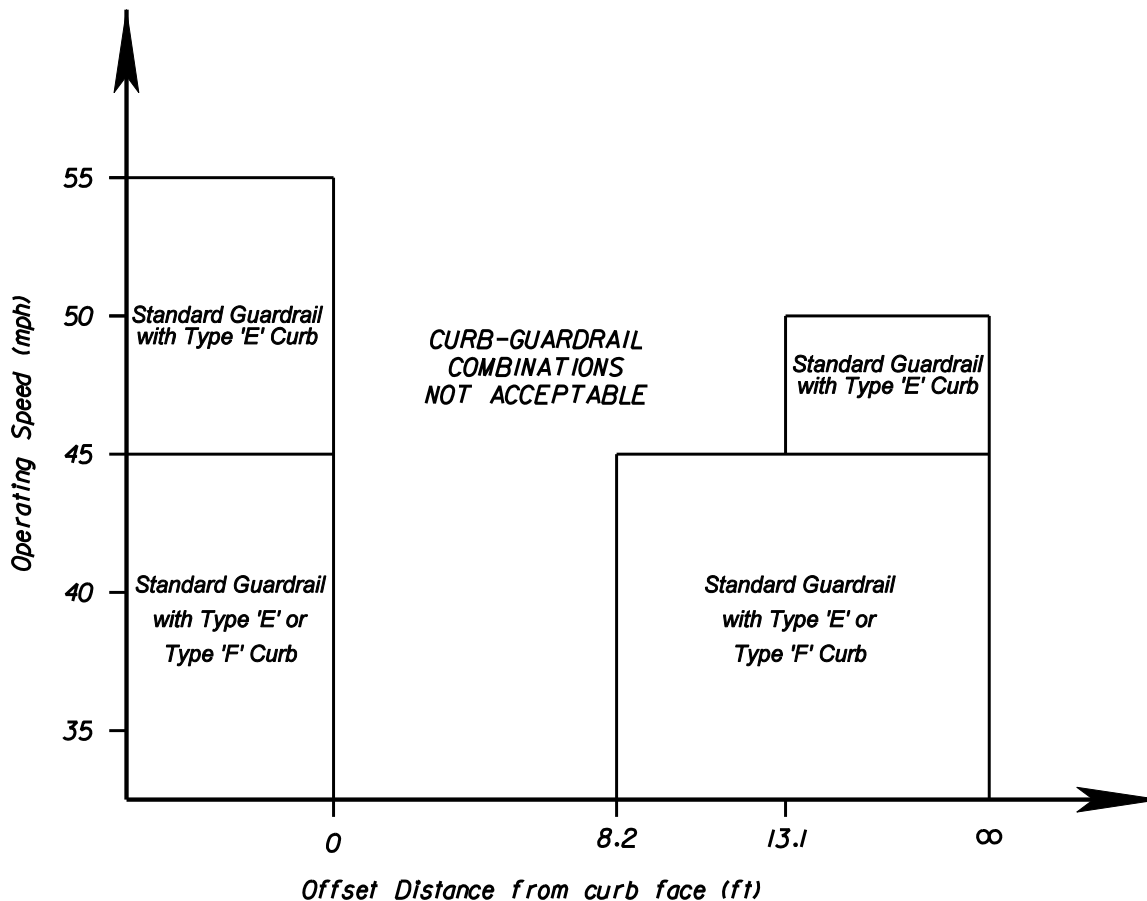

### 4.3.6 Upgrading Existing Barrier Systems

Deficient roadside barriers are generally upgraded in conjunction with other roadway work, such as RRR projects, or through spot or system wide safety improvement projects. In each case the designer must determine the scope and extent of the barrier upgrading to be accomplished. In making this determination, the existing installation should be investigated for what work is necessary to make the installation structurally and functionally adequate. The investigation should consider:

1. Whether there is a need for the barrier. If cost effective, the hazard should be removed, relocated, or redesigned and the barrier removed.

2. Length of need.
3. Proper rail height.
4. Proper flare rate.
5. Adequate offset at terminal end.
6. Proper deflection distance between the barrier and the shielded object.
7. Proper placement with respect to traffic lane.
8. Proper placement with respect to curb.
9. Placement on proper slope.
10. Adequate clear zone area behind yielding terminals.
11. The overall condition of the guardrail/barrier installation.
12. Post type, condition and spacing.
13. Existing unshielded hazards. For spot improvements, only those existing unshielded hazards in the immediate vicinity of the installation being addressed should be reviewed. For RRR projects, all existing roadside hazards within the project corridor should be reviewed for treatment needs.

In some cases the deficiencies will be so obvious that the best course of action is readily apparent. However, many times the deficiencies may be marginal and a decision on the scope and extent of the barrier upgrading will be based on engineering judgment. Factors which should be considered are:

1. Nature and extent of barrier deficiency.
2. Past crash history.
3. Cost effectiveness of recommended improvement.
4. Whether future scheduled reconstruction or RRR work in the 5 year work program will address deficiency.

#### 4.3.6.1 Resetting Guardrail

For those projects that include the resetting of guardrail, refer to the **Standard Specifications**, the **Basis of Estimates Handbook**, and the **Design Standards** for pay items, notes and quantity calculations.



## 4.4 Median Barriers

### 4.4.1 Warrants

A median barrier shall be provided on Interstate and expressway facilities where reconstruction reduces the median width to less than the standard for the facility. No variations or exceptions to this criterion will be approved.

On Interstate and expressway projects, crashes that occurred in the most recent 5-year period within the limits of 1 mile prior to the exit ramp gore to 1 mile beyond the entrance ramp gore shall be reviewed. If 1 or more are determined to be across median crashes, shielding within this area shall be provided. Outside these areas, the District may provide shielding after reviewing the most recent 5-year crash history.

### 4.4.2 Selection

The same barrier types as discussed in **Section 4.3.2** are available as median barriers. In general, the concrete barrier wall is preferable in narrow medians. Where deflection space is adequate, either a double face guardrail or single face guardrail on each side may be used. See the ***Design Standards*** and the ***AASHTO Roadside Design Guide*** for additional guidance.

### 4.4.3 End Treatments

Median barriers can be terminated with any of the treatments discussed in **Section 4.3.3**.

**THIS PAGE LEFT BLANK INTENTIONALLY**

## 4.5 Crash Cushions

Crash cushions are attenuating devices that may be non-redirective or redirective.

### 4.5.1 Warrants

Hazards within the clear zone, that present a more serious collision potential than a crash cushion, warrant the installation of a crash cushion.

### 4.5.2 Selection

Various types of crash cushions and attenuation devices approved for use on Department projects can be found on the Qualified Products List (QPL). Detailed information about these systems is provided in the **Design Standards**, approved QPL drawings, and in each manufacturer's publications. Each system has its own unique physical and functional characteristics. The designer shall indicate in the plans either the specific system to be used at each location, or the options that may be used when one or more crash cushion system is suitable at a given location (in accordance with **Design Standards, Index 430**). The design engineer shall consider the following factors when selecting a system for a particular location:

1. Site characteristics.
2. Structural and safety characteristics of candidate systems.
3. Initial and replacement/repair costs.
4. Expected frequency of collisions.
5. Maintenance characteristics.

Site characteristics and economics dictate the crash cushion selection. Sand barrels are relatively low in initial cost, but usually must be completely replaced when struck, so are more appropriate in locations with a low likelihood of collision. There are a number of other systems that have higher initial costs but can be repaired after collisions relatively quickly and inexpensively, so are more appropriate where frequent collisions are expected. The ability of maintenance forces to perform routine maintenance and to place a crashed system back into service quickly should be a major consideration. Crash cushions that require stocking unusual and expensive parts or that are complex to replace should not be selected.

A pay item has been established for Optional Permanent Crash Cushions, (2)544-75-40, beginning with the January 2006 letting. This pay item is applicable ONLY for crash cushions

being used to shield the ends of standard concrete barrier wall, standard W-beam guardrail, or thrie-beam guardrail. Use of this pay item for these locations is not mandatory. The designer may still call for a specific system brand and use the corresponding pay item. However, the reasons for restricting to a specific brand must be documented in the project design file. For crash cushions used to shield hazards other than standard concrete barrier wall, standard W-beam guardrail, or thrie-beam guardrail, designers must continue to identify the specific system to be used and use the corresponding pay item, as has been done in the past.

The Optional Crash Cushion pay item is to be used in conjunction with ***Design Standards, Index 430***. ***Index 430*** includes crash cushion length information for each of the crash cushion systems approved for use under this pay item. Designers should note that certain crash cushion options may have lengths that do not provide the proper length of need, and others may have lengths that exceed the available space at a given location. These should be eliminated from the list of options shown in the plans.

### 4.5.3 Design

Standard details of systems listed on the QPL for typical installations shielding guardrail ends and barrier wall ends can be found in the ***Design Standards*** and approved QPL drawings. In addition, some of these systems have standard details for shielding wide hazards. For non standard applications, crash cushion suppliers normally provide design assistance for their systems. Special designs should be based on providing performance meeting NCHRP 350 crash test criteria for the established design speed of the facility. For special designed inertial systems where the ***AASHTO Roadside Design Guide*** charts are used, the maximum average deceleration level should not exceed approximately 7 g's.

All terrain within the likely approach of a vehicle should be relatively flat. An impacting vehicle should strike the unit at normal height, with the vehicle's suspension system neither collapsed nor extended. Curbs exceeding 4 inches in height shall not be used in the approach area of a crash cushion.

Care must be taken that the design of a crash cushion system does not create a hazard to opposing traffic.

The nose of all crash cushions shall be delineated with reflective material or standard object markers, as indicated in the ***Design Standards***.

For additional guidance on the selection of crash cushions for temporary use in work zones, see ***Chapter 10***.

## 4.6 Roadside Appurtenances

### 4.6.1 Sign Supports

All sign supports, except overhead cantilever, truss type or bridge or barrier wall mounted, shall be breakaway as defined in the ***AASHTO Standard Specifications for Structural Supports for Highway Signs, Luminaires and Traffic Signals*** and the ***AASHTO Roadside Design Guide***. Sign supports shall be of an acceptable and crashworthy design as described in the ***Design Standards***. Supports not meeting the breakaway criteria should not be installed within the clear zone. Sign supports not meeting these requirements, that must be installed within the clear zone, shall be protected by a barrier or crash cushion.

### 4.6.2 Mailbox Supports

Mailbox supports shall be of an acceptable crashworthy design, as described in the ***Design Standards***.

### 4.6.3 Other Appurtenances

The ***Design Standards*** contains design criteria for numerous other roadside appurtenances.

### 4.6.4 Location Criteria

Most breakaway mechanisms are designed to be impacted at bumper height, typically about 20 inches above the ground. If impacted at a significantly higher point, the bending moment in the breakaway base may be sufficient to bind the mechanism, resulting in non-activation of the breakaway device. For this reason, it is important that breakaway supports not be located in ditches or on steep slopes where a vehicle is likely to be partially in sprung suspension at the time of impact.

### 4.6.5 Bus Benches and Transit Shelters

Refer to ***Table 2.11.9*** for criteria on the placement of shelters and benches.

## 4.7 Non-Standard Roadside Safety Devices

The Qualified Products List (QPL) includes proprietary devices and products that have been evaluated against implemented FDOT Specifications and Standards, and found to meet those Specifications and/or Standards. The majority of proprietary roadside safety devices needed for use on the State Highway System are identified on the QPL. However, just as FDOT Specifications and Standards do not address every potential highway need, the QPL does not cover every type of roadside safety device that may be available on the market. Unique situations will sometimes require unique devices. Examples of available devices that are not covered by FDOT Specifications and Standards include barrier wall gates, aesthetic guard rails, temporary steel barriers, crashworthy stop gates, and others. When the need arises for a unique crashworthy device not covered on the QPL, the designer must carefully investigate the applicability of the device for the situation, as well as the crash performance characteristics of the device. For some of these devices, the State Roadway Design Office may have information and be of assistance in establishing the appropriateness of the device for a given situation.

The designer must document the following:

1. FHWA Acceptance Letter
2. Crash Test Reports, including review of all test results. All performance characteristics must be reviewed, including post impact vehicle behavior and post impact test article deflection, debris scatter, etc.
3. Compatibility with adjacent and/or connecting standard roadside safety devices.
4. Maintenance requirements and characteristics, including coordination with the District Maintenance Office.
5. For devices such as barrier gates, operational plans and training as appropriate.

The designer will also be responsible for providing special plan details, technical specifications, and method of pay as appropriate.