

The Reinforced Earth Company

8614 Westwood Center Drive Suite 1100, Vienna, Virginia 22182 (703) 821-1175

TERRATREL™ A WIRE FACED MSE WALL SYSTEM

FINANCIAL PROJECT ID	STATE PROJ. NO.	SHEET NO.

DESIGN CRITERIA

- DESIGN IS BASED ON THE ASSUMPTION THAT THE MATERIAL WITHIN, BEHIND, AND BENEATH THE REINFORCED VOLUME; METHODS OF CONSTRUCTION; AND QUALITY OF PREFABRICATED MATERIALS SHALL CONFORM TO SPECIFICATION SECTION 548.
- SOIL PARAMETERS:
SEE WALL CONTROL DRAWINGS FOR SOIL CHARACTERISTICS OF FOUNDATION MATERIAL TO BE USED IN THE DESIGN OF THE SYSTEM. THE CONTRACTOR SHALL PROVIDE SOIL DESIGN PARAMETERS FOR BACKFILL MATERIAL BASED ON THE ACTUAL SOIL CHARACTERISTICS UTILIZED AT THE SITE. THE VALUES OF FRICTION ANGLE (ϕ), AND COHESION (c), AND TOTAL UNIT WEIGHT (γ) SHALL BE PROVIDED IN THE SHOP DRAWINGS.
- THE MAXIMUM APPLIED BEARING PRESSURE AT THE FOUNDATION LEVEL IS AS SHOWN ON THE WALL ELEVATIONS FOR EACH DESIGN CASE. IT IS THE RESPONSIBILITY OF THE ENGINEER TO DETERMINE THAT THIS APPLIED BEARING PRESSURE IS ALLOWABLE FOR A SPECIFIC SITE.
- ANY UNSUITABLE FOUNDATION MATERIAL BELOW THE REINFORCED VOLUME, AS DETERMINED BY THE ENGINEER, SHALL BE EXCAVATED AND REPLACED WITH SUITABLE MATERIAL OR OTHERWISE STABILIZED AS DIRECTED BY THE ENGINEER.
- THE MINIMUM FACTORS OF SAFETY REQUIRED FOR DESIGN
OVERTURNING = 2.0
SLIDING = 1.5
INTERNAL PULLOUT = 1.5 (ALLOWABLE DEFORMATION = 0.75 INCH)
BEARING CAPACITY = 2.5
OVERALL STABILITY = 1.5
STEEL SOIL REINFORCEMENT (AT END OF DESIGN LIFE)
= $0.55F_y$ (FOR HA STRIPS)
= $0.50F_u$ (AT NET SECTION OF BOLTED CONNECTION)
WIRE FACING (AT END OF DESIGN LIFE) = $0.48F_y$
MAXIMUM PULLOUT FACTOR
 $f^* = 1.5$ (FOR SAND)
 $f^* = 2.0$ (FOR LIMEROCK)

LAYOUT

- FOR LAYOUT OF THE WALLS, SEE RETAINING WALL CONTROL PLANS.

CONSTRUCTION

- BACKFILL MATERIAL SHALL BE COMPACTED IN ACCORDANCE WITH SECTION 548. INSTALLATION OF REINFORCEMENTS SHALL BE PERMITTED ONLY AFTER PLACEMENT AND COMPACTION OF THE BACKFILL MATERIAL HAS REACHED THE REQUIRED LEVEL.
- FOR STRUCTURES IN EXCESS OF 20' IN HEIGHT, THE FINISHED GRADE IN FRONT OF THE WALL SHALL BE PLACED AND COMPACTED BEFORE WALL CONSTRUCTION EXCEEDS A HEIGHT OF 20'. FINISHED GRADE BACKFILL SHALL BE COMPACTED TO 95% OF AASHTO T-180 UNLESS OTHERWISE DIRECTED BY THE ENGINEER.

CONFLICTING STRUCTURES

- IF MANHOLES AND DROP INLETS ARE PRESENT, THEY SHALL BE LOCATED AS SHOWN ON THE WALL ELEVATIONS.
- IF PILES ARE LOCATED WITHIN THE REINFORCED VOLUME, THEY SHALL BE DRIVEN PRIOR TO CONSTRUCTION OF THE WALL UNLESS A METHOD TO PROTECT THE STRUCTURE, WHICH IS ACCEPTABLE TO THE ENGINEER AND THE REINFORCED EARTH COMPANY, IS PROPOSED AND APPROVED IN WRITING.
- IT IS THE CONTRACTOR'S RESPONSIBILITY TO DETERMINE THE LOCATION OF ANY GUARDRAIL POSTS WITHIN THE REINFORCED VOLUME. PRIOR TO THE PLACEMENT OF THE TOP LAYERS OF REINFORCEMENTS, INDIVIDUAL REINFORCEMENTS MAY BE SYSTEMATICALLY SHIFTED TO AVOID THE POST LOCATIONS IF AUTHORIZED BY THE ENGINEER. ANY DAMAGE DONE TO THE REINFORCEMENTS DUE TO INSTALLATION OF GUARDRAIL POSTS SHALL BE REPAIRED BY THE CONTRACTOR AT THE CONTRACTOR'S EXPENSE.
- IF EXISTING OR FUTURE STRUCTURES, PIPES, FOUNDATIONS, OR GUARDRAIL POSTS WHICH ARE WITHIN THE REINFORCED VOLUME INTERFERE WITH THE NORMAL PLACEMENT OF REINFORCEMENTS AND SPECIFIC DIRECTION HAS NOT BEEN PROVIDED ON THE PLANS, THE CONTRACTOR SHALL NOTIFY THE ENGINEER TO DETERMINE WHAT COURSE OF ACTION SHOULD BE TAKEN, UNLESS SHOWN OTHERWISE.
- THE CONTRACTOR IS RESPONSIBLE FOR GRADUALLY DEFLECTING UPPER REINFORCEMENTS DOWNWARD TO AVOID CONFLICTS WITH PAVING AND SUBGRADE PREPARATION. THE CONTRACTOR'S ATTENTION IS DIRECTED ESPECIALLY IN SITUATIONS WHERE ROADWAY SUPERELEVATION AND/OR SOIL MIXING ARE ANTICIPATED.

MATERIALS

- ONLY THE FOLLOWING MATERIALS ARE SUPPLIED BY THE REINFORCED EARTH COMPANY:
- PREFABRICATED WIRE FACING PANELS
- SOIL REINFORCEMENTS
- HAIRPIN CONNECTORS
- BOLT SETS
- CONNECTOR RODS
- SOIL RETENTION FABRIC
ANY OTHER MATERIALS CALLED FOR IN THE CONTRACT PLANS OR SPECIFICATIONS ARE TO BE SUPPLIED BY THE CONTRACTOR.
- SOIL REINFORCEMENT LENGTHS
THE REINFORCEMENT LENGTHS SHOWN ON THE PLANS ARE MEASURED FROM THE BACK FACE OF THE WIRE FACING PANELS TO THE LIMIT OF THE SELECT BACKFILL MATERIAL, AND ARE THE LENGTHS USED IN THE REINFORCEMENT DESIGN CALCULATIONS.
- THE REINFORCED EARTH COMPANY SUPPLIES FACING PANELS AND ACCESSORIES TO BE USED IN CONJUNCTION WITH OTHER MATERIALS IN THE CONSTRUCTION OF THE REINFORCED EARTH RETAINING WALLS DETAILED HEREIN. THE CONSTRUCTION AND QUALITY CONTROL PROCEDURES MANUAL FURNISHED BY THE REINFORCED EARTH COMPANY IS INTENDED TO PROVIDE A GENERAL EXPLANATION OF THE SYSTEM. IT IS THE CONTRACTOR'S OBLIGATION TO DEVISE A PROJECT SPECIFIC ERECTION SEQUENCE, PANEL UNLOADING, HANDLING AND BRACING SYSTEM, AND FALL PROTECTION SYSTEM. THE BRACING SYSTEM SHOWN IN THE CONSTRUCTION AND QUALITY CONTROL PROCEDURES MANUAL IS GENERAL IN NATURE AND DOES NOT ACCOUNT FOR PROJECT SPECIFIC CRITERIA. COMPLIANCE WITH THE GUIDELINES IN THIS MANUAL DOES NOT RELIEVE THE CONTRACTOR OF ITS RESPONSIBILITY TO ADHERE TO THE PROJECT PLANS, SPECIFICATIONS, AND CONTRACT DOCUMENTS OR COMPLIANCE WITH ALL FALL PROTECTION, SAFETY, LAWS, STANDARDS AND PROCEDURES AT THE JOBSITE. CONTRACTORS SHALL TAKE SPECIAL PRECAUTIONS TO PREVENT THE PANELS FROM SHIFTING OR FALLING DURING THE ERECTION PROCESS.
- THE REINFORCED EARTH COMPANY IS RESPONSIBLE FOR INTERNAL STABILITY OF THE STRUCTURE ONLY. EXTERNAL STABILITY DESIGN INCLUDING FOUNDATION AND SLOPE STABILITY IS THE RESPONSIBILITY OF OTHERS.
- THIS DRAWING CONTAINS INFORMATION PROPRIETARY TO THE REINFORCED EARTH COMPANY, AND IS BEING FURNISHED FOR THE USE OF THE FLORIDA DEPARTMENT OF TRANSPORTATION ONLY IN CONNECTION WITH FDOT PROJECTS, AND THE INFORMATION CONTAINED HEREIN IS NOT TO BE TRANSMITTED TO ANY OTHER ORGANIZATION UNLESS SPECIFICALLY AUTHORIZED IN WRITING BY THE REINFORCED EARTH COMPANY. THE REINFORCED EARTH COMPANY IS EXCLUSIVE LICENSEE IN THE UNITED STATES UNDER PATENTS ISSUED TO HENRI VIDAL, AND THE FURNISHING OF THIS DRAWING DOES NOT CONSTITUTE AND EXPRESSED OR IMPLIED LICENSE UNDER THE VIDAL PATENTS.
- THESE DRAWINGS ARE CERTIFIED WITH RESPECT TO THE INTERNAL STABILITY OF REINFORCED EARTH STRUCTURES ONLY.

THIS SYSTEM SHALL BE USED IN SLIGHTLY OR MODERATELY AGGRESSIVE ENVIRONMENTS ONLY
TERRATREL WIRE WALL

THE SEALED RECORD OF THIS STANDARD IS ON FILE IN THE ROADWAY DESIGN OFFICE.
INTERIM STANDARD IN ENGLISH UNITS APPLICABLE TO DESIGN STANDARDS BOOKLET PUBLISHED IN ENGLISH UNITS.

STATE OF FLORIDA DEPARTMENT OF TRANSPORTATION		
RETAINING WALL SYSTEM THE REINFORCED EARTH COMPANY TERRATREL WIRE WALL		
INTERIM STANDARD	APPROVED BY 	
THIS INDEX IS A SUPPLEMENT TO THE DESIGN STANDARDS, BOOKLET DATED JANUARY 2002.		
REVISION NO.	SHEET NO.	INDEX NO.
04	1 of 4	05115

Revised: 04-22-03

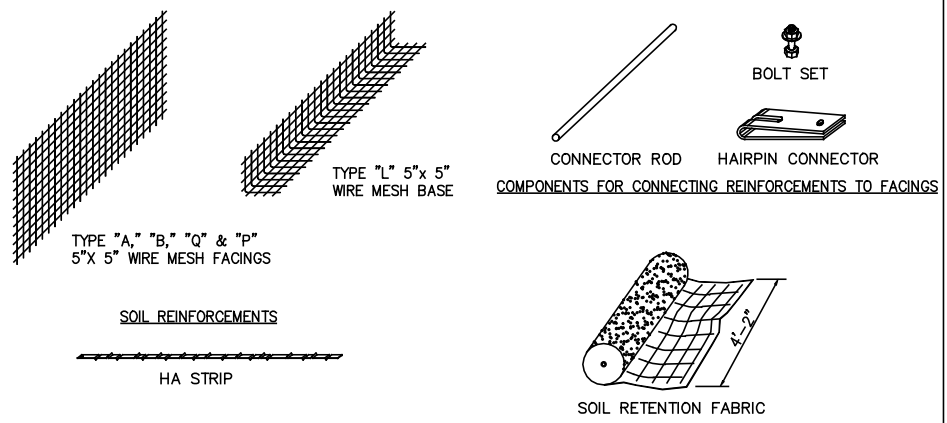

TERRATREL WIRE WALL COMPONENTS

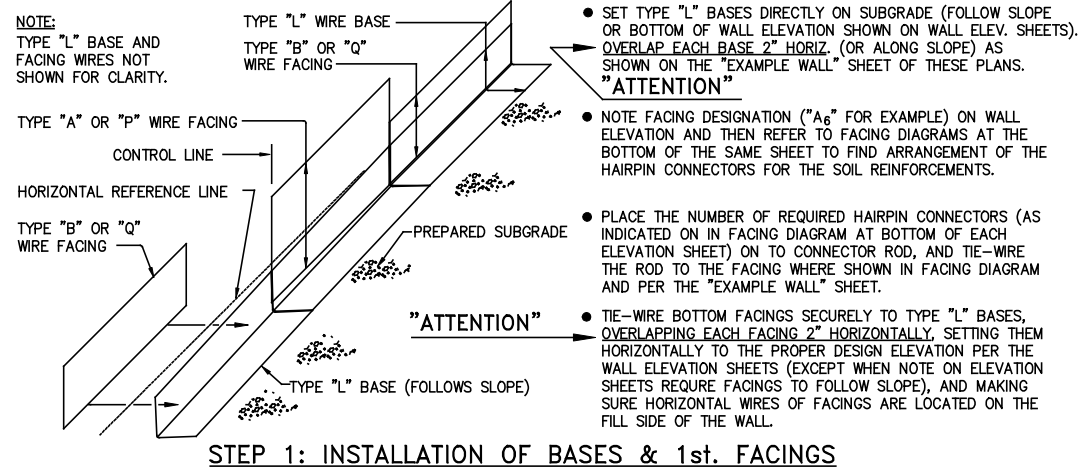

STEP 1: INSTALLATION OF BASES & 1st. FACINGS

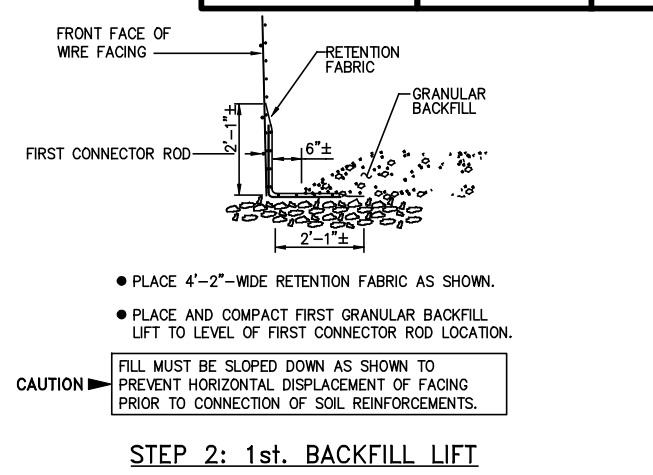

STEP 2: 1st. BACKFILL LIFT

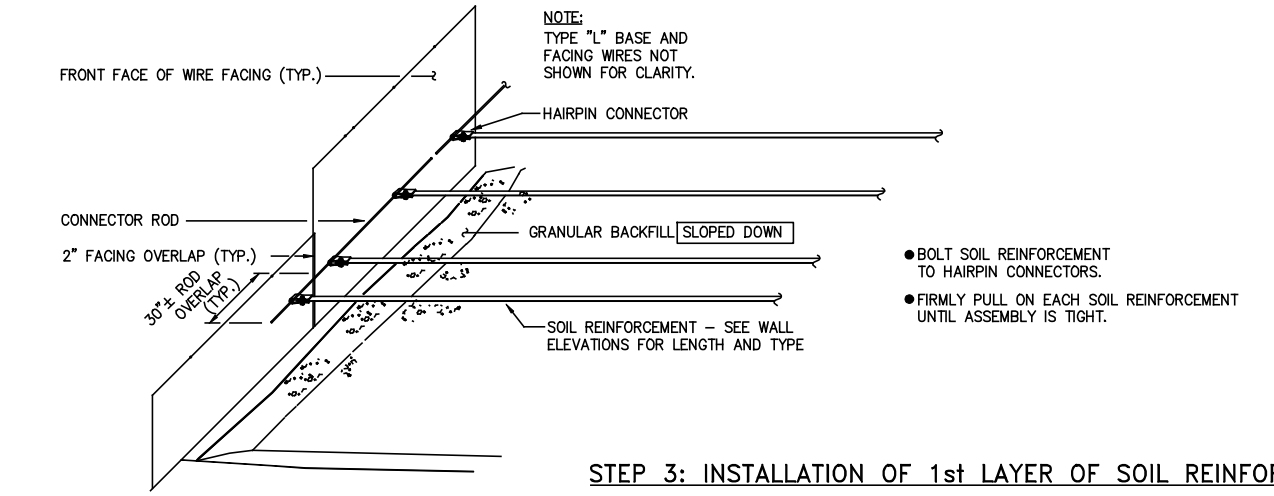

STEP 3: INSTALLATION OF 1st LAYER OF SOIL REINFORCEMENTS

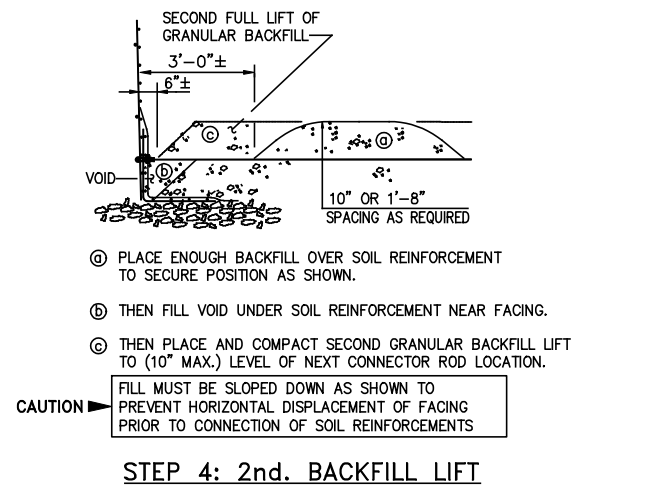
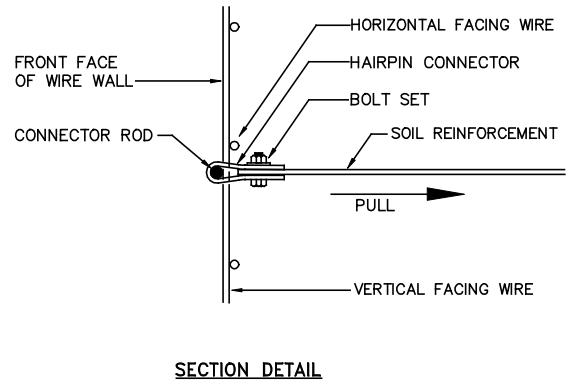

STEP 4: 2nd. BACKFILL LIFT

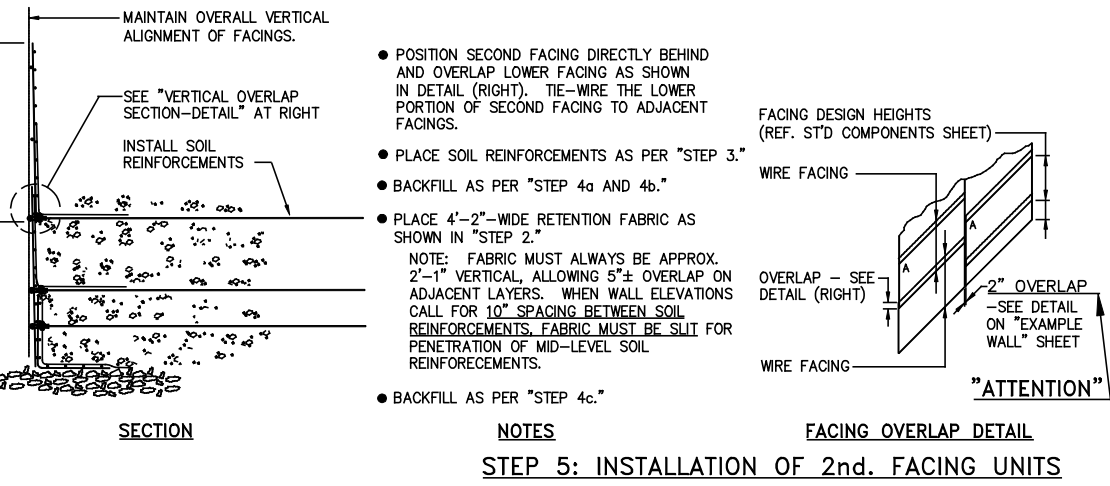

STEP 5: INSTALLATION OF 2nd. FACING UNITS

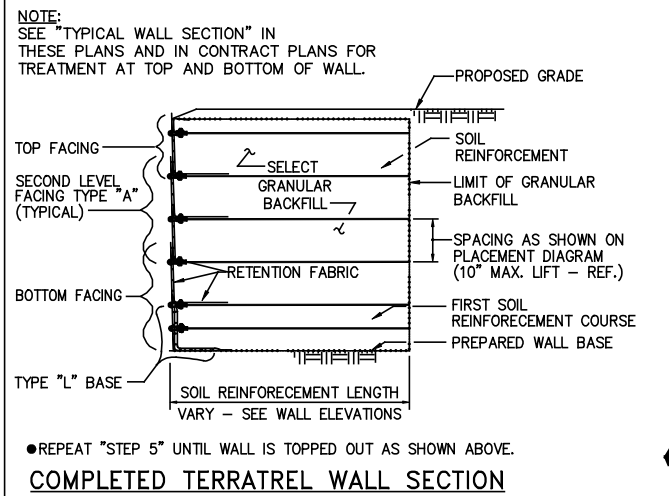
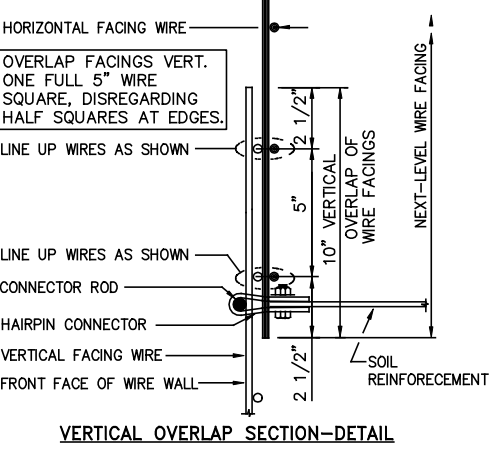

COMPLETED TERRATREL WALL SECTION

THE SEALED RECORD OF THIS STANDARD IS ON FILE IN THE ROADWAY DESIGN OFFICE.

INTERIM STANDARD IN ENGLISH UNITS APPLICABLE TO DESIGN STANDARDS BOOKLET PUBLISHED IN ENGLISH UNITS.

THIS SYSTEM SHALL BE USED IN SLIGHTLY OR MODERATELY AGGRESSIVE ENVIRONMENTS ONLY
TERRATREL WIRE WALL

STATE OF FLORIDA DEPARTMENT OF TRANSPORTATION		
RETAINING WALL SYSTEM THE REINFORCED EARTH COMPANY TERRATREL WIRE WALL		
INTERIM STANDARD	APPROVED BY <i>W. J. [Signature]</i> State Structures Design Engineer	INDEX NO.
THIS INDEX IS A SUPPLEMENT TO THE DESIGN STANDARDS, BOOKLET DATED JANUARY 2002.	REVISION NO. 04	SHEET NO. 2 of 4
		INDEX NO. 05115

Revised: 04-22-03

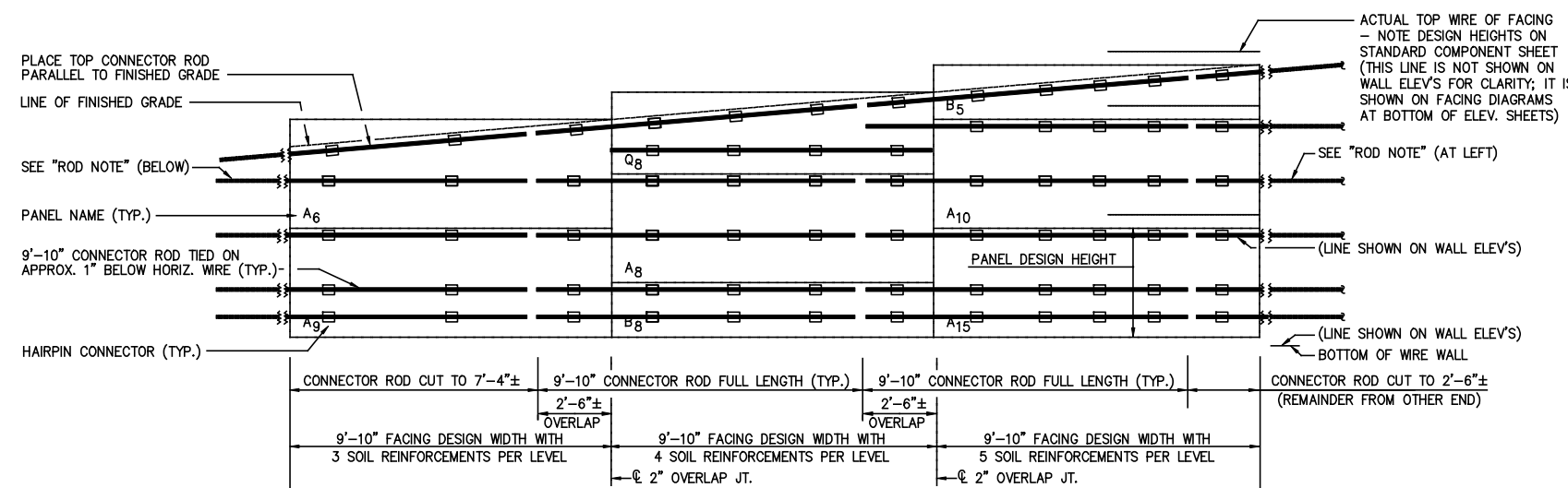

ELEVATION - EXAMPLE WALL
(VERTICAL AND HORIZONTAL WIRES OF FACINGS NOT SHOWN FOR CLARITY)

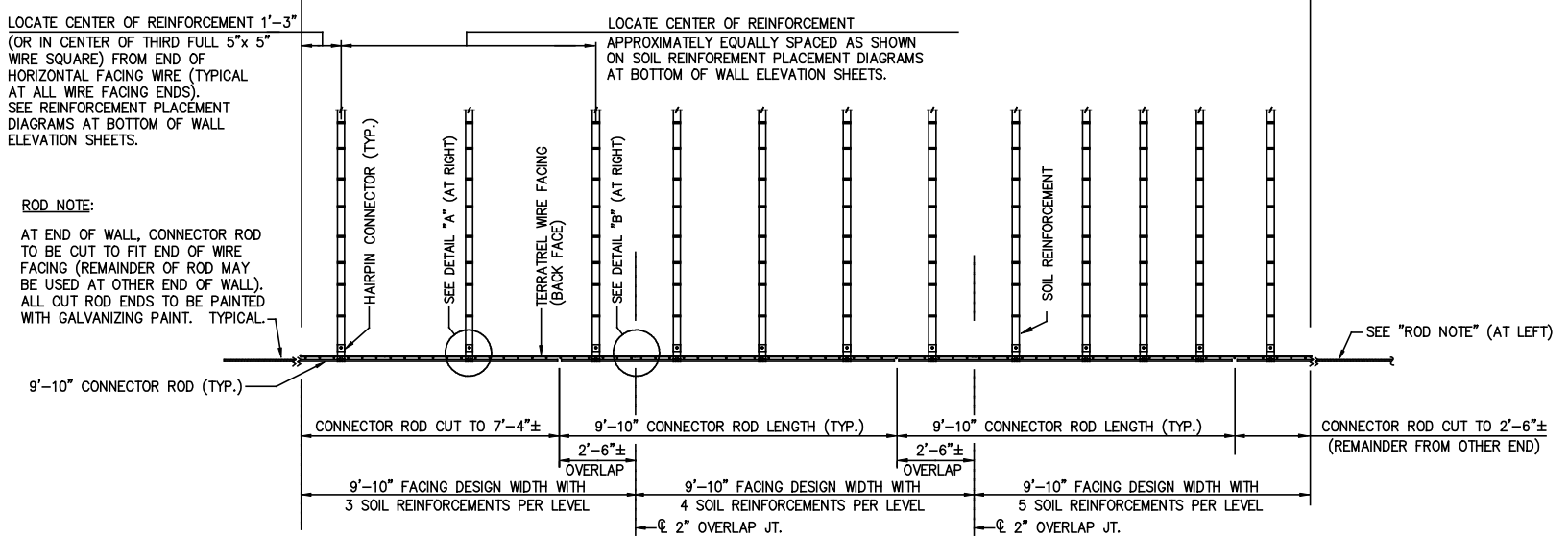

PLAN - EXAMPLE WALL

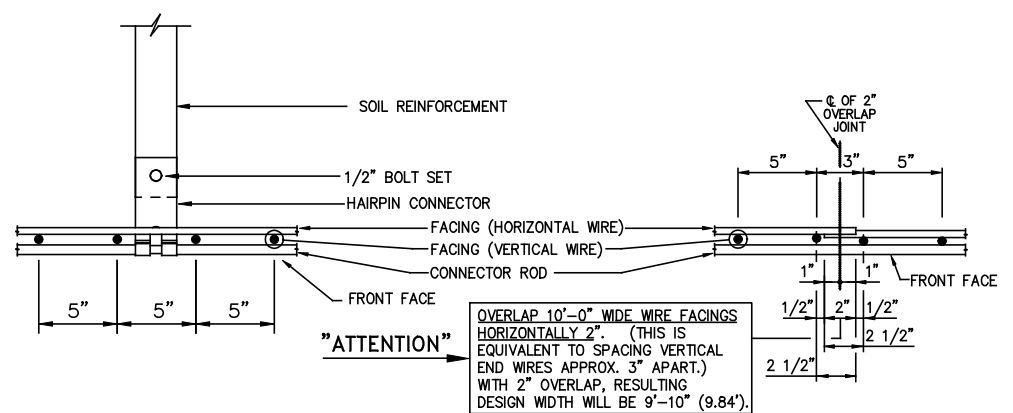

PLAN DETAIL 'A'
SOIL REINFORCEMENT CONNECTION

"ATTENTION"
OVERLAP 10'-0" WIDE WIRE FACINGS HORIZONTALLY 2". (THIS IS EQUIVALENT TO SPACING VERTICAL END WIRES APPROX. 3" APART.) WITH 2" OVERLAP, RESULTING DESIGN WIDTH WILL BE 9'-10" (9.84').

PLAN DETAIL 'B'
WIRE FACING OVERLAP JOINT

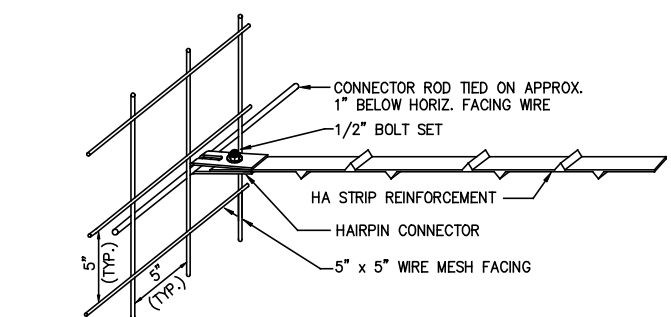

CONNECTION OF HA STRIP TO FACING IN PERSPECTIVE

THIS SYSTEM SHALL BE USED IN SLIGHTLY OR MODERATELY AGGRESSIVE ENVIRONMENTS ONLY
TERRATREL WIRE WALL

THE SEALED RECORD OF THIS STANDARD IS ON FILE IN THE ROADWAY DESIGN OFFICE.

INTERIM STANDARD IN ENGLISH UNITS APPLICABLE TO DESIGN STANDARDS BOOKLET PUBLISHED IN ENGLISH UNITS.

STATE OF FLORIDA DEPARTMENT OF TRANSPORTATION		
RETAINING WALL SYSTEM THE REINFORCED EARTH COMPANY TERRATREL WIRE WALL		
INTERIM STANDARD	APPROVED BY	INDEX NO.
THIS INDEX IS A SUPPLEMENT TO THE DESIGN STANDARDS, BOOKLET DATED JANUARY 2002.	REVISION NO. 04	SHEET NO. 3 of 4
		05115

Revised: 04-22-03

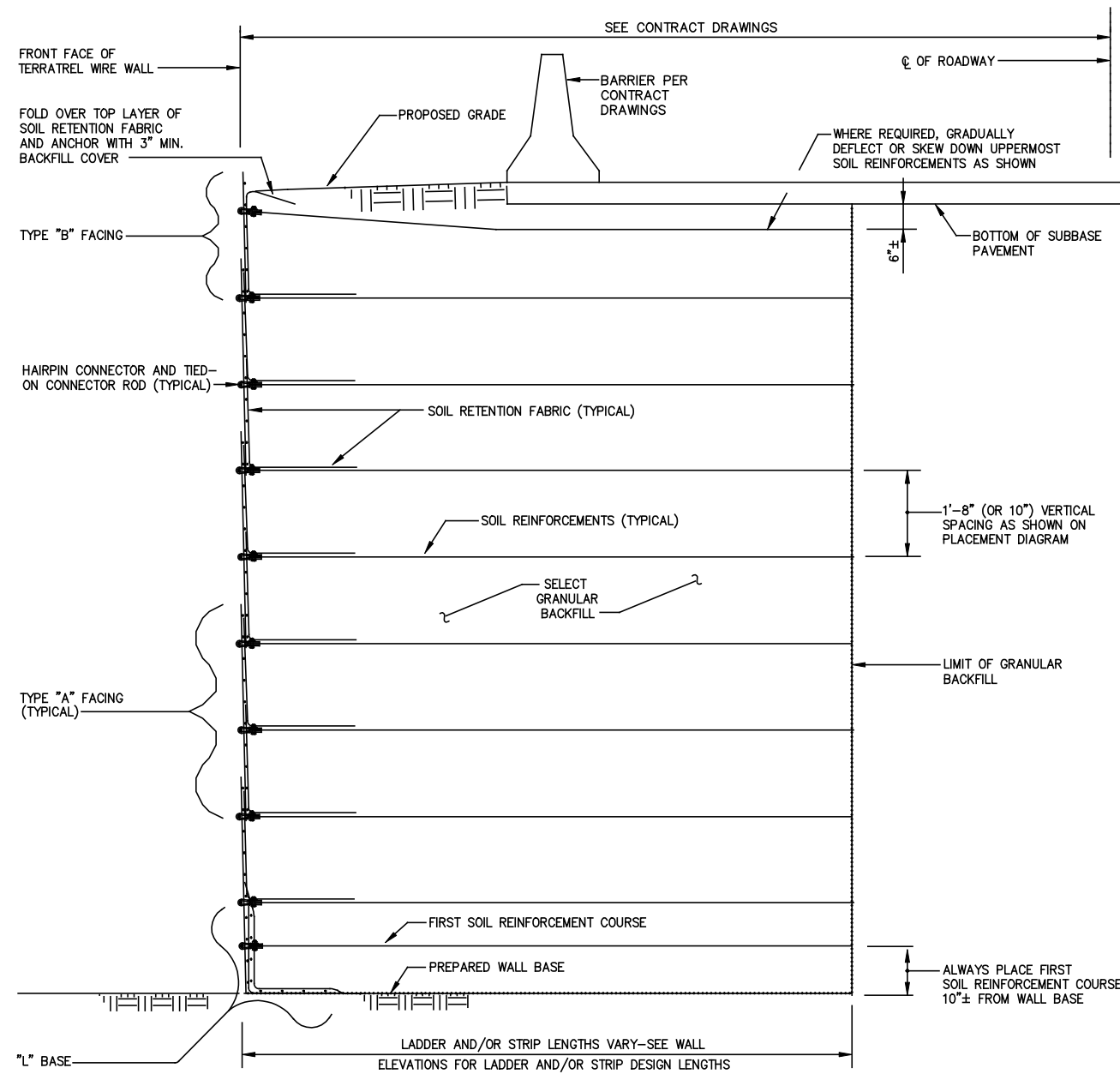

TYPICAL WIRE WALL SECTION

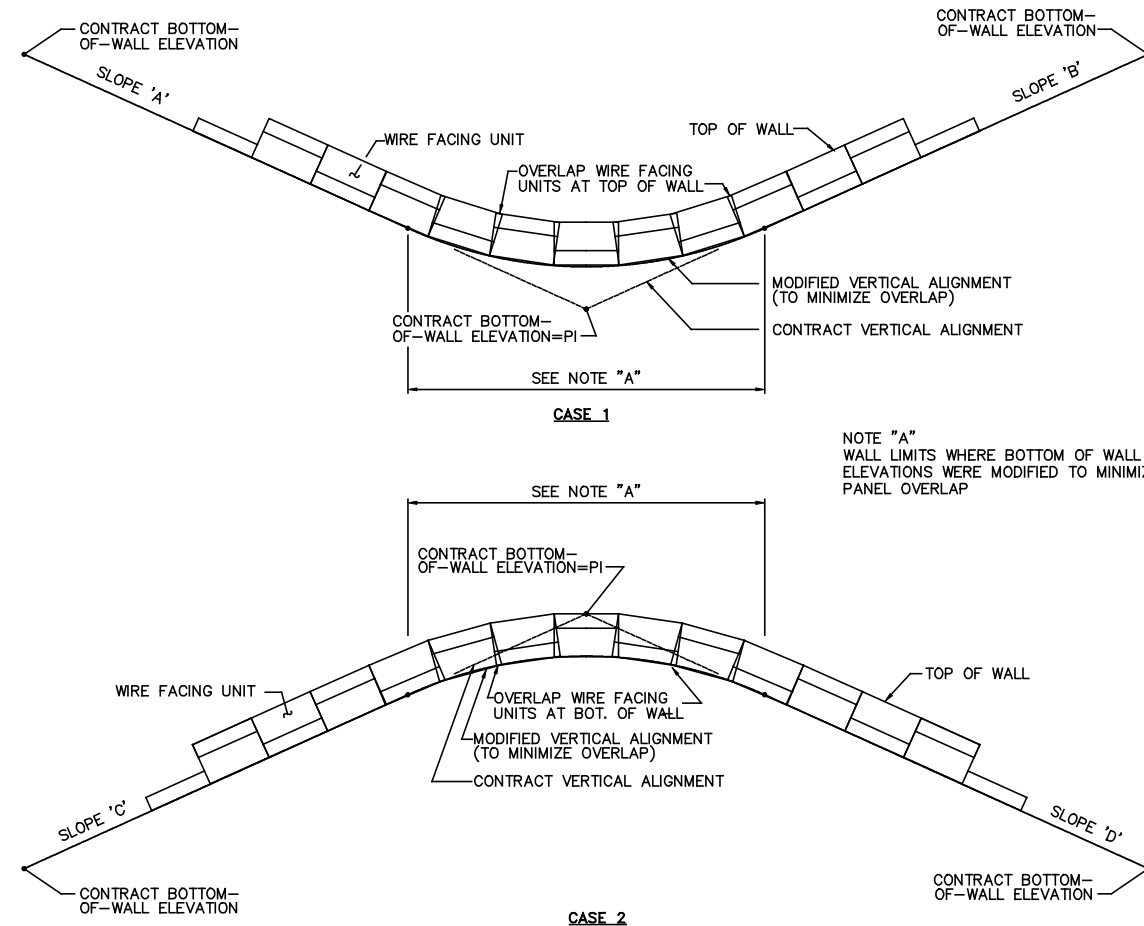

VERTICAL ALIGNMENT DIAGRAMS

(SLOPES HAVE BEEN SHOWN EXAGGERATED FOR CLARITY)
 ADDING THE CURVES TO THE VERTICAL ALIGNMENT IS OPTIONAL, AND WHEN USED,
 MAY ELIMINATE OVERLAPPING FOR LOW WALLS WITH SMALL CHANGES IN SLOPE.

THE SEALED RECORD OF THIS STANDARD IS ON FILE IN THE ROADWAY DESIGN OFFICE.

INTERIM STANDARD IN ENGLISH UNITS APPLICABLE TO DESIGN STANDARDS BOOKLET PUBLISHED IN ENGLISH UNITS.

THIS SYSTEM SHALL BE USED IN SLIGHTLY OR MODERATELY AGGRESSIVE ENVIRONMENTS ONLY
 TERRATREL WIRE WALL

Revised: 04-22-03

STATE OF FLORIDA DEPARTMENT OF TRANSPORTATION		
RETAINING WALL SYSTEM THE REINFORCED EARTH COMPANY TERRATREL WIRE WALL		
INTERIM STANDARD	APPROVED BY 	
THIS INDEX IS A SUPPLEMENT TO THE DESIGN STANDARDS, BOOKLET DATED JANUARY 2002.		
REVISION NO.	SHEET NO.	INDEX NO.
04	4 of 4	05/15