



Florida Method of Test for MOISTURE-DENSITY RELATIONS OF SOILS USING A 4.54-kg [10-lb] RAMMER AND A 457-mm [18-in.] DROP

Designation: FM 1-T 180

SCOPE

This method of test is intended for use in determining the relationship between soil density and moisture content for soils specific to Florida. The procedures outlined in this document are modifications to the national standard AASHTO T 180 and are intended to provide analytical results for use in transportation engineering in Florida. This method also includes provisions and deviation from the national and Florida specific standards when preparing and compacting soil materials for determination of a Limerock Bearing Ratio.

FM 1-T 180 is identical to AASHTO T 180 except for the following provisions:

REFERENCED DOCUMENTS

AASHTO Standards:

AASHTO T 193 – The California Bearing Ratio (CBR)

AASHTO M 145 – Classification of Soils and Soil-Aggregate Mixtures for Highway Construction Purposes

AASHTO T 27 – Sieve Analysis of Fine and Coarse Aggregates

FM Standards:

FM 5-515 – Limerock Bearing Ratio (LBR)

PROCEDURE

1. Delete Section 1.2 and the engineer will determine which method shall govern.
2. “Calibration of Measure” in sections 3.1.1 and 3.1.2 shall not be required. Volume of molds shall be determined by calculation of the volume of a cylinder by use of the measured diameter and height. Mold volume can be assumed to be 0.0333 ft³ for 4 inch diameter molds or 0.0750 ft³ for 6 inch diameter molds as long as the mold remains within the tolerances outlined for volume, diameter, and height outlined in



sections 3.1.1 and 3.1.2. Alternative mold assemblies such as LBR or CBR molds, as allowed per AASHTO Note 2, shall be verified as outlined in section 7.1.1 and 7.1.5 of this method.

3. Add the following required apparatus to section 3:

3.1. Jaw Crusher – An electric-powered mechanical jaw crusher having a minimum jaw plate dimension of 2.25-in x 3.50-in (57mm x 90 mm) set at a maximum opening of $\frac{3}{4}$ -in (19 mm) with an under tolerance of $\frac{1}{8}$ -in (3.175 mm).

4. Replace sections 4.3 and sections 8.3-8.4 with the following procedure:

4.1 Materials used for base: For materials used for base, particles larger than $\frac{3}{4}$ -in (19-mm) cannot be separated from the sample before crushing. Immediately after completion of air drying, the entire sample shall be passed incrementally through a mechanical jaw crusher so that the entire sample passes between the jaw crusher's plates. The sample shall be passed through the crusher one time. After crushing, the sample shall be passed over a $\frac{3}{4}$ -in (19-mm) sieve. Those pieces not reduced to below $\frac{3}{4}$ -in (19-mm) in size after one pass through the crusher shall be discarded. The material shall then be passed over a No. 4 (4.75-mm) sieve, and the percentages retained on the No. 4 sieve and passing the No. 4 sieve shall be determined and recorded. Sieving shall be for a sufficient time period and in such a manner as described in AASHTO T 27 section 8.4.

4.2 Materials used for subgrade: The materials used for subgrade shall be passed through 2 inch, $\frac{3}{4}$ -in and No. 4 (50-mm, 19-mm, and 4.75-mm) sieves without crushing, taking care to thoroughly break up the aggregations in such a manner as to avoid reducing the natural size of the individual particles. Any clay or silt aggregations shall be broken down until they will pass through a No. 4 (4.75-mm) sieve. The percentages retained on each sieve are then recorded. The material retained on the 2 inch (50-mm) sieve shall be discarded. The material passing the 2 inch (50-mm) sieve and retained on the $\frac{3}{4}$ -in (19-mm) sieve shall be weighed, removed from the soil and replaced with an equal mass of material passing the $\frac{3}{4}$ -in (19-mm) sieve and retained on the No. 4 (4.75-mm) sieve. The material shall then passed through a No. 4 (4.75-mm) sieve and the percentages retained on the No. 4 sieve and passing the No. 4 sieve shall be determined and recorded.

NOTE: If the material retained on the No. 4 (4.75-mm) sieve is seven percent (7%) or less of the total sample mass, the material may be added



back into the sample and thoroughly mixed with no correction.

- 4.3 The materials separated on the plus No. 4 sieve and minus No. 4 sieve shall then be recombined into sample specimens of at least 11 pounds (4.99-kg) using the gradation percentage of each recorded in the previous step. For specimens used to determine a Limerock Bearing Ratio, recombined specimens shall weigh at least 12 pounds (5.44-kg). The minimum number of specimens obtained for compaction shall be in compliance with the requirements of the AASHTO test method. For non-cohesive well drained soils (A-1, A-3, and A-2-4 non-plastic) a minimum of 4 specimens representing two points below the optimum moisture, one at or near optimum, and one past optimum shall be acceptable. Each specimen shall be prepared using the same applicable gradation percentages determined in AASHTO T 180 sections 4.1 or 4.2 of this method (Additional portions may be needed to define points on the compaction curves).
 - 4.4 Apply AASHTO Note 6 to all soil types except A-3 and Non-Plastic A-2-4. For A-3 and Non-Plastic A-2-4 soils, the Engineer will decide whether to apply Note 6 (if specimens are used to determine a Limerock Bearing Ratio apply Note 6 regardless of soil type). Preparation of separate samples with varying moisture contents is an acceptable option for all types of soils, regardless of the soaking period. If separate samples are prepared, apply Note 6 immediately prior to compacting the materials and determine moisture contents as outlined in AASHTO T 180 sections 5.4, 9.4, or by ASTM D 4643 (Determination of Water (Moisture) Content of Soil by the Microwave Oven Method).
5. Prior to compaction of specimens, soil-water mixtures prepared in section 4 of this method shall be placed in covered containers and allowed to stand in accordance with Table 1.

Table 1. Dry Preparation Method Soaking Times

Classifications (based on AASHTO M 145)	Minimum Soaking Times (Hours)
A-3	No Requirement
A-2-4 (Non-Plastic)	3
A-1, A-2-4 (Plastic), A-2-5, A-2-6, A-2-7, A-4, A-5, A-6, A-7	12



6. The wording “approximately equal layers” shall be defined as, for 5 layers, 1.1 ± 0.5 inches. To quickly ensure proper layer height during compaction it is recommended to permanently mark the compaction rammer in such a way that when the rammer face makes contact with the surface of the soil the height of each layer can be identified. Just prior to compacting each layer, the amount of soil placed into the mold shall be slightly more than the required layer thickness after light tamping. Immediately after compaction of each layer the height of the soil should fall within 0.5 inches of the mark on the rammer.
7. For compaction of specimens used to determine a Limerock Bearing Ratio (per FM 5-515):
 - 7.1. Molds shall conform to the requirements of section 3.1.2 with the following exceptions:
 - 7.1.1. Mold shall have a volume of $0.0982 \pm 0.001 \text{ ft}^3$ ($0.00278 \pm 0.00003 \text{ m}^3$). The volume of new molds shall be determined in accordance with AASHTO T 19 “Calibration of Measurement” before it is placed in service. Annual re-verification of mold volume for in-service molds may be determined by calculation from physical measurements of diameter and height only if the mold diameter, height, and volume remain within the tolerances outlined in this method. If the calculated sample volume (calculated mold volume minus volume spacer disk occupies) is within $\pm 1.2\%$ of 0.0750 ft^3 the sample volume can be assumed to be 0.0750 ft^3 during testing. The calculated sample volume should be determined by the following equation:
$$\text{Sample Volume (ft}^3\text{)} = \frac{\text{Mold Volume (ft}^3\text{)}}{6 \text{ inches (Mold Height)}} \times 4.59 \text{ inches (Sample Height)}$$
 - 7.1.2. Mold shall have a height of 6.00 ± 0.026 inches (152.40 ± 0.70 mm) as shown in appendix A.
 - 7.1.3. Base plate shall contain 28 open holes 0.06 ± 0.03 inches (1.6 ± 0.8 mm) in diameter.
 - 7.1.4. Spacer disc shall be used that consists of a metal disc 5.938 ± 0.031 inches (150.8 ± 0.8 mm) in diameter and 1.41 ± 0.026 inches (35.80 ± 0.70 mm) in height as shown in appendix B is inserted as a false bottom in the cylinder mold during compaction. This would give a net cylinder height of 4.584 ± 0.018 inches. The flat surface of the spacer disc shall be plane to 0.005 inches (0.13 mm).



- 7.1.5. AASHTO Note 2 may be applied for use of alternative mold assemblies such as a mold and spacer disc meeting the specification of AASHTO T 193 for mold and spacer disk height, diameter, and volume. Sample volume shall be determined as noted in AASHTO T 180 section 6.1.1 with the exception of using the appropriate mold height in the equation to determine sample volume.
- 7.2. Compacting specimens shall be performed with a manual rammer meeting the AASHTO T 180 requirements of section 3.2.1, or a mechanical rammer meeting the requirements of section 3.2.2 with the following provisions:
- 7.2.1. The mechanical rammer contact face shall be flat with a wear tolerance of 0.01 inch (0.25 mm) and have the shape of a sector of a circle of a radius equal to 2.90 ± 0.02 inches (73.70 ± 0.51 mm) as shown in appendix C. The manufactured area of the sector face shall be 3.14 ± 0.03 in² (2025.80 ± 19.2 mm²). The minimum allowable in-service area for sector faced rammers is 3.09 in² (1996.6 mm²) which is equivalent to that of a manual rammer with a minimum in-service diameter of 1.985 in (50.42 mm).
- 7.3. Adding Moisture - Each of the separate portions shall be thoroughly mixed with amounts of water sufficient to cause each of the moisture contents of the samples to vary by approximately one percent with the lowest moisture content being approximately three percentage points below the optimum moisture content (moisture content increments shall not exceed 1.5%). The moisture contents selected shall bracket the optimum moisture content, thus providing samples which, when compacted, will increase in mass to the maximum density and then decrease in mass. The samples of soil-water mixtures shall be placed in covered containers and allowed to stand prior to compaction in accordance with Table 1. For the purpose of selecting a standing time, it is not required to perform the actual classification procedure described in AASHTO M 145 (except in the case of referee testing), if previous data exist which provide a basis for classifying the sample.
- 7.4. Compaction of specimens for determination of a Limerock Bearing Ratio (per FM 5-515) shall meet the requirements of Method D.



FLORIDA DEPARTMENT OF TRANSPORTATION

State Materials Office
5007 NE 39th Avenue
Gainesville, Florida 32609

May 10, 2017

- 7.5. Remove sections 9.4-9.5. Immediately continue testing per FM 5-515.
- 7.6. Repeat the above procedure for all required specimens compacted at varying moisture contents beginning approximately three percentage points below the optimum moisture content and increasing the moisture until the optimum moisture content is exceeded by at least one percentage point.



FLORIDA DEPARTMENT OF TRANSPORTATION

State Materials Office
5007 NE 39th Avenue
Gainesville, Florida 32609

May 10, 2017

Metric Equivalents	
0.0001 in.	0.0025 mm
0.001 in.	0.025 mm
0.0625 + 0.03125 in	1.60 + 0.80 mm
0.25 in.	6.35 mm
2.00 ± 0.010 in.	50.80 ± 0.25 mm
1.41 + 0.026 in.	35.80 + 0.70 mm
1.954 + 0.005 in	49.63 + 0.13 mm
2.0625 in	52.39 mm
2.5 in.	63.00 mm
2.90 ± 0.02 in.	73.7 ± 0.51 mm
3.75 in.	95.25 mm
5.875 in.	149.23 mm
5.9375 + 0.031 in	150.81 + 0.79 mm
5.9375 in	151.0 mm
6.00 + 0.026 in.	152.40 + 0.70 mm
6.00 in.	152.40 mm
6.50 in.	165.10 mm
3.0 in ² .	1935.48 mm ²
5.00 ± 0.01 lb	2.27 ± 0.005 kg
10.0 lb	4.53 kg

The values above apply to appendices A through C



FLORIDA DEPARTMENT OF TRANSPORTATION

State Materials Office
5007 NE 39th Avenue
Gainesville, Florida 32609

May 10, 2017

APPENDICES

APPENDIX A: LBR MOLD

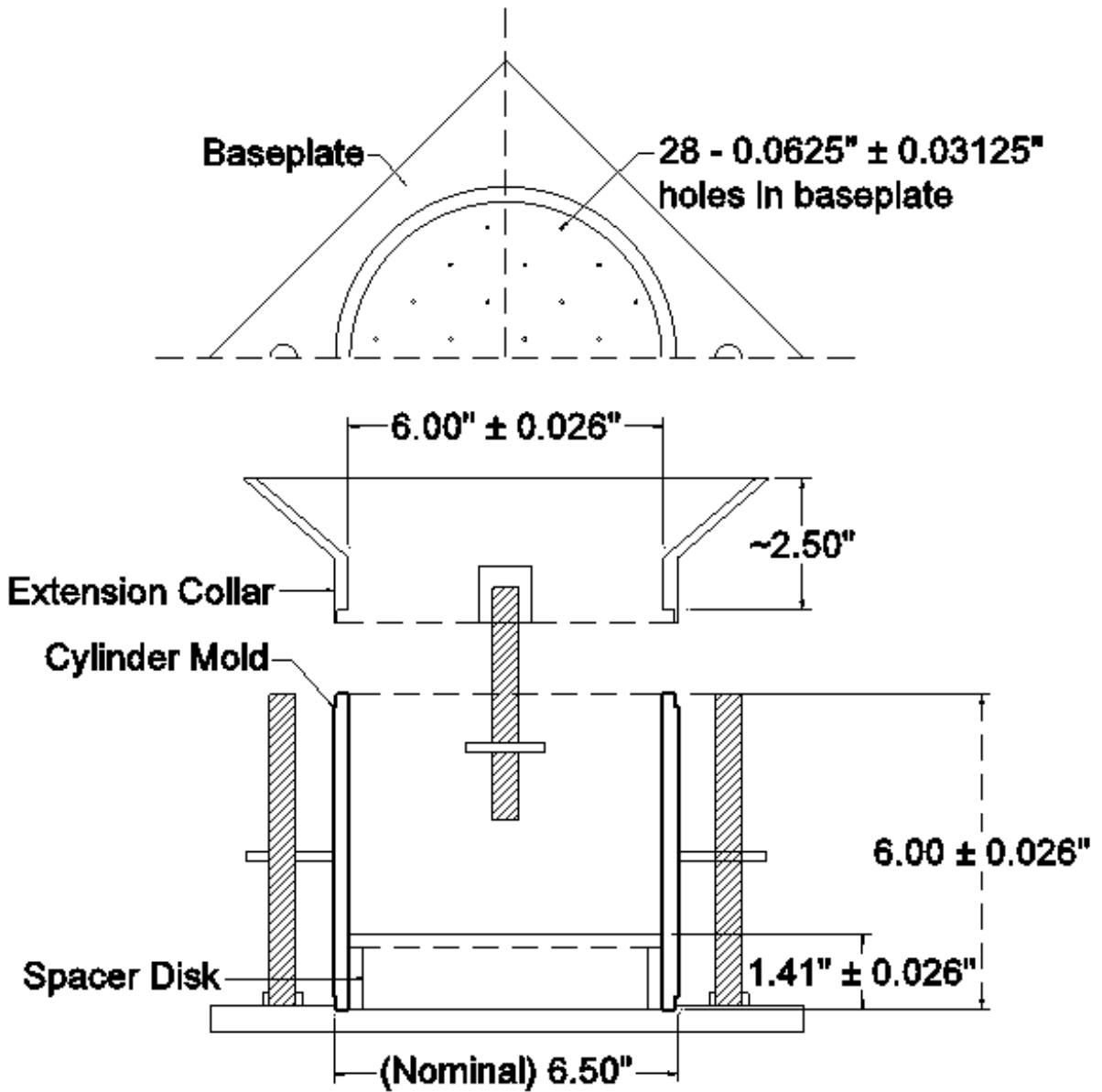

APPENDIX B: LBR TESTING APPARATUS – PART I

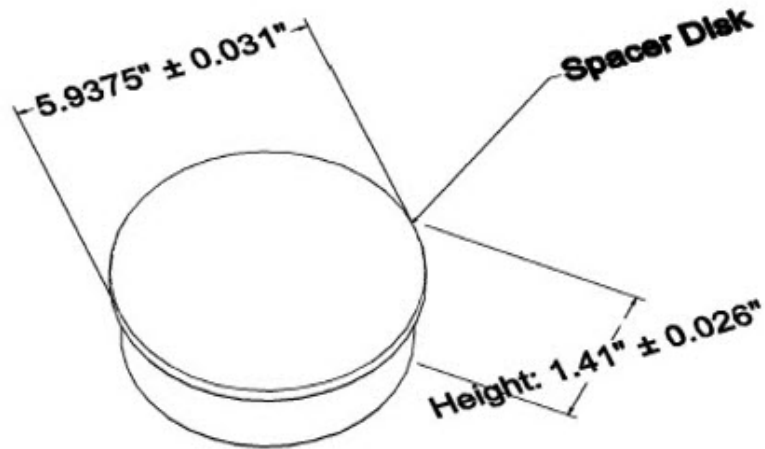

APPENDIX C: LBR TESTING APPARATUS – PART II

