

Generator Power for Signalized Intersection Package

May 27, 2006

	Page
1. Generator Power for Signalized Intersections Retrofit and New Cabinet Minimum Specifications	1- 3
2. Cabinet Installation Details (FDOT Design Standards Index No. 17841)	4
3. Florida Department of Transportation Guidelines for Operating Signalized Intersection with Generator Power	5- 8
4. City of Tallahassee Transfer Switch Installation	9-11
5. Automatic Transfer Switch and Generator Panel	12

A678-16 Generator Power for Signalized Intersections Retrofit

A678-16.1 Description

This Section specifies the generator power for signalized intersection controller cabinet retrofits. The specifications for new controller cabinets are included in A676-1 CONTROLLER CABINET*. The Florida Department of Transportation Guidelines for Operating Signalized Intersections with Generator Power is located at:

http://www.dot.state.fl.us/TrafficOperations//pdf/050903_Generator_Guidelines.pdf

A678-16.2 Design

Refer to the Department's Design Standards regarding connections and dimensions.

A678-16.3 Materials

A678-16.3.1 Transfer Switch

The transfer switch shall be mounted on the side of the controller cabinet, as close as possible to the AC main circuit breaker, away from any pedestrian walkway and shall not be mounted on a controller cabinet door. The bottom of the transfer switch shall be located at least 24 inches above the concrete pad to avoid flood and splash water. The transfer switch outside cover shall be labeled "Emergency Generator Connector" in red.

The transfer switches shall be sized to meet the amperage rating of the AC power service overcurrent protection rating and shall be provided with manually operated toggle type transfer switches.

To provide for automatic transition from generator power back to utility power after utility power is restored, an automatic transfer switch may be used instead of a manual transfer switch.

A678-16.3.1.1 Ratings

The transfer switch shall withstand closing and interrupting power ratings of 20,000 amps. The transfer switch shall be rated for continuous duty at 100% load. The transfer switch shall conform to the applicable requirements of UL 1008 for emergency system total load. The transfer switch shall be fully rated for all types of loads, inductive and resistive, without derating, either open or closed.

A678-16.3.1.2 Construction

The transfer switch shall have a lockable door with tamper-resistant hinge to completely enclose all components, and be furnished with a lock with two #2 keys. The door shall have a movable plate to cover the opening for the generator cable when the generator is not connected. The enclosure shall be constructed of heavy-duty, 12 gauge, Type 5052-H32 aluminum or rust and corrosion-resistant stainless steel rated for outdoor use.

The transfer switch shall be constructed to prevent cross connection of power sources.

An integrally mounted NEMA L5 male power inlet rated at 125V shall be provided inside a lockable enclosure at the front of the transfer switch.

The transfer switch shall be capable of being operated manually under fully rated load conditions.

Use a single pole 120V transfer switch. The generator and utility supply source neutral leads are tied together in the cabinet. The transfer switch only switches the phase conductor (hot) and not the neutral.

A678-16.3.1.3 Enclosure

The enclosure shall meet the requirements of NEMA 3R, 4, or 4X as rated for outdoor environments. The transfer switch shall include a 3/16-inch-thick ethylene propylene diene monomer (EPDM) closed-cell sponge rubber gasket meeting UL-recognized component requirements.

A678-16.3.1.4 Finish

NEMA 3R aluminum, or NEMA 4 or 4X stainless steel may be left unpainted.

A678-16.3.1.5 Accessories

Provide an “utility-on” light that can be observed from outside of the transfer switch enclosure to indicate that the utility power has been restored.

A678-16.3.2 Direct Connection

For direct connection operations, the egress cover shall be weather tight and lockable. The AC service neutral lead shall be connected to the cabinet when the generator is connected.

A678-16.3.3 Generator

Sections 702.5 and 702.6 of the National Electrical Code govern the selection and use of standby power systems and provide requirements for transfer equipment. At minimum, use a 120V, 60 Hz, 3000-watt generator, or two 1500-watt generators hooked in parallel using a parallel kit with 30-amp locking plug with inverter. For existing generator without inverter, a power conditioner shall be installed to ensure clean sinusoid AC power to the controller and conflict monitor. The generator shall be sized to match the full load requirements of the controller cabinet. Generators shall be able to operate continuously for 8 hours on a single tank of fuel.

A678-16.3.4 Cable

For transfer switch operations, use the power cord that meets or exceeds the requirement of transfer switch. The amperage of the conductors and twist-lock connectors from the generator terminals to the disconnect switch shall match or exceed the output rating on the generator’s overcurrent protection. Use 50 feet or less of #10 AWG or larger wire.

A678-16.3.5 Uninterrupted Power Supply (UPS)

The UPS units listed on the Department’s Approved Product List shall be used when required.

*** A676-1 Description**

This Section specifies the minimum requirements for the certification of traffic signal controller cabinets (NEMA and Type 170) used to house traffic controllers, controller accessories, and other traffic control devices.

The state standard for all traffic signal controller cabinets shall include a generator panel. At a minimum, the generator panel shall consist of a manual transfer switch, or an automatic transfer switch where required, and a twist-lock connector for generator hookup. The transfer switch knob and twist-lock connector shall be located and labeled on a panel easily accessible behind a separate lockable door. The door shall be equipped with a tamper-resistant hinge. The door assembly shall be weatherproof and dustproof. The door shall have a movable plate to cover an opening for the generator cable. The generator panel shall be located as close as possible to the AC main circuit breaker. The generator panel shall not be located on main cabinet doors or back doors. The connection to a generator or other external power source shall be a waterproof, secure connection. The connection shall allow authorized personnel to access, connect, and secure an external power source to the cabinet for power restoration within 5 minutes of arrival at the location.

Manufacturers seeking approval for their device shall provide the Department with a unit to be evaluated by the State Traffic Engineer in accordance with these specifications. Documentation indicating the furnished unit meets all requirements specified shall be provided before any evaluation is to take place.

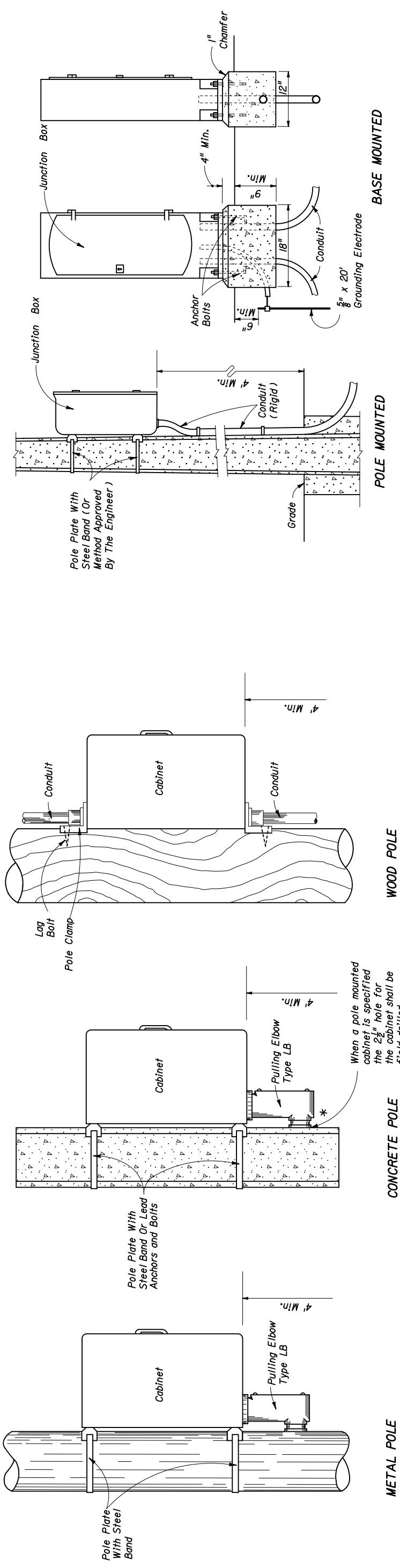

Liquid tight flexible conduit is approved for use from the electrical disconnect to the cabinet when both are installed on the same pole.

POLE MOUNTED CABINET

* If holes for cabinet mounting require relocation, original holes shall be filled in with concrete or covered with a non corrosive cover plate.

Notes:

- The number, size and orientation of conduit sweep will vary according to site condition or locations. Two spare 2" PVC conduits shall be provided in all bases. The spares shall exit in the direction of the center rear of the cabinet base, into a pull box and capped with a weather tight fitting. If obstructions prevent the spare conduit from exiting to the rear, or the rear of the cabinet is located on the R/W line, a side exit of the spare conduits will have to be approved by the project engineer. All spare conduit sweeps shall be capped with a weather proof fitting.
- Meet all grounding requirements of Section 620 of the Standard Specifications.
- New Controller Cabinet Installation shall meet the requirements of Section A676-1 of the Minimum Specifications for Traffic Control Signal Devices (MSTCSD).

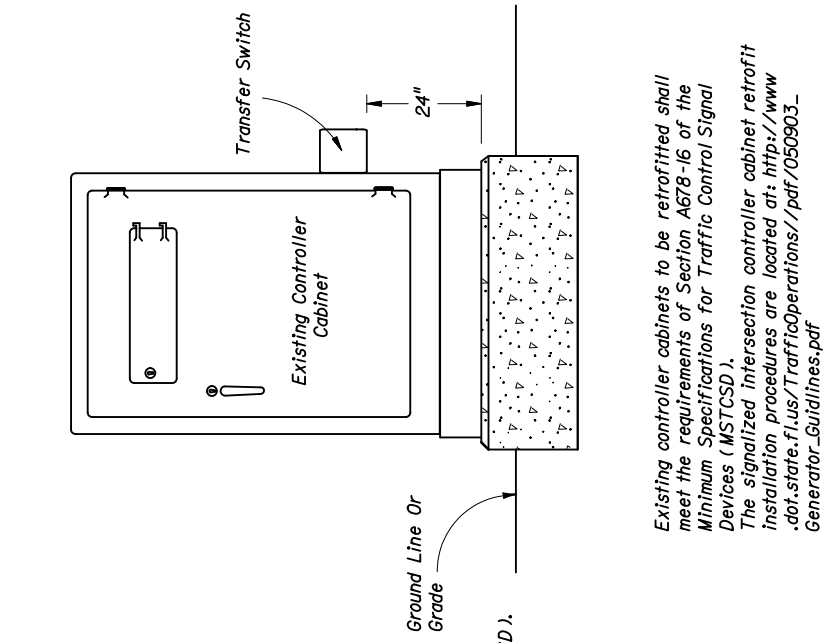
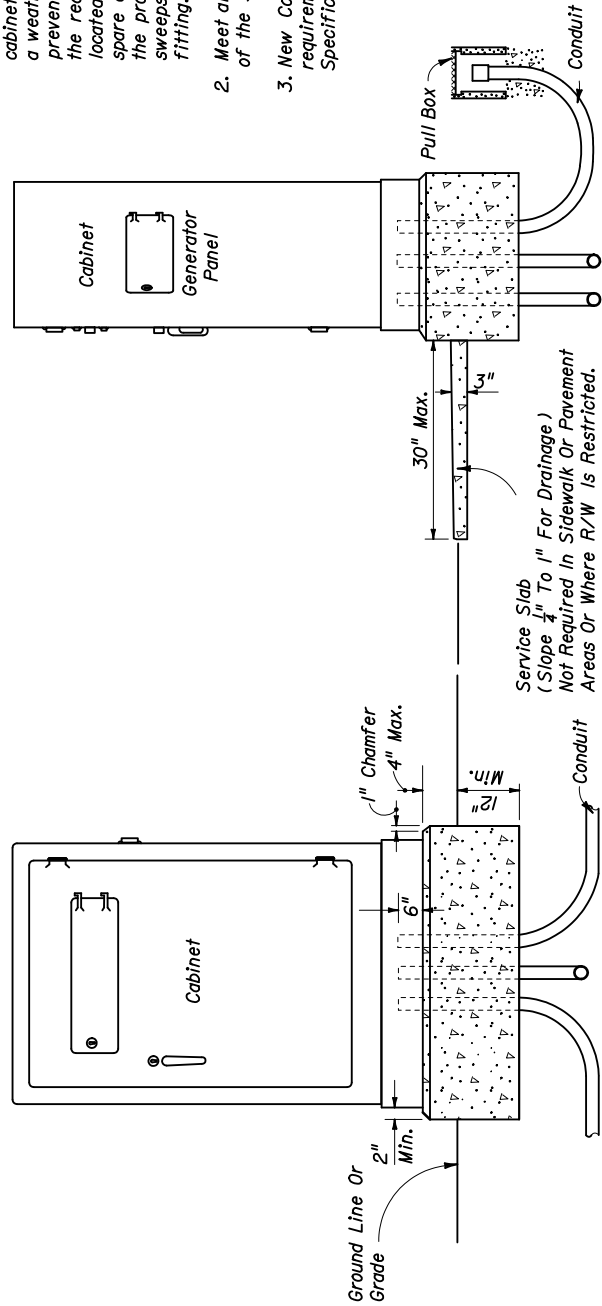

PEDESTAL MOUNTED



2008 FDOT Design Standards

BASE MOUNTED CABINET

CABINET INSTALLATION DETAILS

Last Revision 07/10/07

Sheet No. 1 of 1

Index No. 17841

Florida Department of Transportation Guidelines for Operating Signalized Intersections with Generator Power

Rev. May 24, 2006

General Information

This document provides general operating guidelines for the use of portable generators to power signalized intersections that have lost normal electrical service following a hurricane or other disaster. Two different connection methods are described below and instructions given for technicians to install the generator.

Follow the manufacturers' instructions for use of portable generators. When the installation is complete, make sure the generator is well secured with one or more locks to prevent theft.

For the transfer switch method of generator installation, be sure to specify the desired color scheme for the various leads when ordering transfer switches from the manufacturer. Also specify whether the intersection needs a transfer switch/disconnect switch, since they will have different model numbers.

The Florida Department of Transportation has conditionally approved transfer switches on the APL. These transfer switches are available with a 30-amp rating for LED traffic signals and 50-amp rating for incandescent traffic signals.

Sections 702.5 and 702.6 of the National Electrical Code govern the selection and use of standby power systems and provide requirements for transfer equipment.

Prior to storage or shipment of portable generators, all gasoline must be drained from the fuel tanks. Once that has been done, shut off the gas tank valve, then crank the engine and run it until it quits to make certain that all gas is out of the carburetor. This must be done *before* the units are strapped to the pallets. It is recommended that portable generators be stored or shipped four to a pallet. The units should be secured to the pallet with metal straps and shrink-wrapped prior to transport or storage.

Materials

- Use a minimum 3000-watt generator, or two 1500-watt generators hooked in parallel using a parallel kit (30-amp locking plug with inverter).
- Select portable generators that can operate continuously for 8 hours on a single tank of fuel.
- For transfer switch operations (the preferred method), use the cord the manufacturer supplied with the transfer switch.
- For direct connection operations, the operator may retrofit his own cable. Use a 15-amp, heavy duty extension cord that is 15 to 25 feet in length. Cut off the female end of the extension cord and expose the white and black leads to wire directly to the cabinet. See complete guidelines in Section II.

I. Generator Connection Using Transfer Switch (Preferred Method)

(a) Connection Guidelines:

1. Mount and secure the transfer switch to the side of the traffic controller cabinet.
2. Visually inspect the intersection to ensure it is capable of running on power. The operator may need to repair or replace any downed or damaged signal heads.
3. Shut main AC breaker **off** at the pole.
4. Remove the utility wire lead from the AC+ input terminal of the controller cabinet.
5. Wire the transfer switch to the circuit as indicated in the following schematic diagram. The black lead must be used for **load**, the red lead for **utility**, white lead to white, and green lead to green.

Transfer Switch Schematic

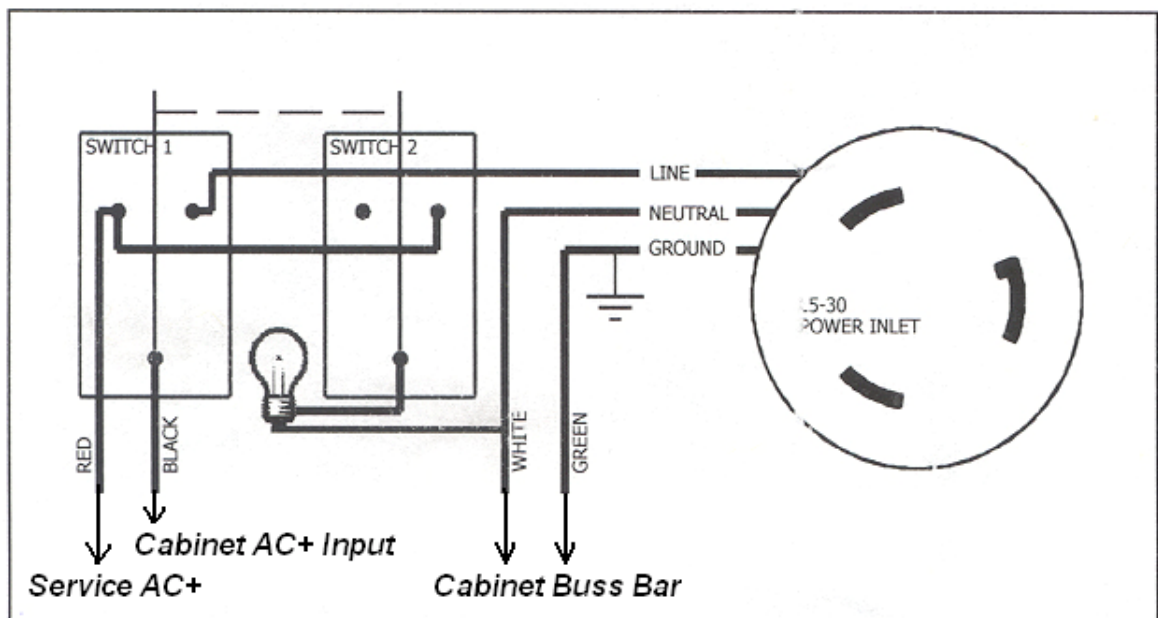

6. After making repairs and installing the transfer switch, flip the transfer switch breaker to the generator position.
7. Turn the main AC breaker/disconnect to the **on** position.
8. Plug in the supplied generator cord *from* the generator panel *to* the generator plug in the transfer switch box.
9. Crank the generator. The cabinet light, power to detectors, load switches, etc., should be restored.
10. The transfer switch is equipped with an utility-on light, which will come on when main AC power is restored. (Transfer switches will not allow generator backflow into the main AC system.)
11. When operator see the utility-on light is on, this indicates that the main AC power has been restored.

12. Verify that the traffic signals are functioning normally.

(b) Disconnection Guidelines:

1. Flip the transfer switch breaker to the AC power position. The traffic controller cabinet will be operating on main AC power.
2. Turn off the generator.
3. Unplug the generator cord from the transfer switch.
4. Unplug the generator cord from the generator panel.
5. Close and lock the transfer switch box.
6. Unchain the generator from the pole and move it to another location (don't forget the power cord).
7. If the generator is not needed any more, follow the shipping and storage procedure above.

II. Direct Connection of Generator (Alternate Method)

(a) Connection Guidelines:

1. Visually ensure the intersection is capable of running on power, i.e., no downed or damaged signal heads.
2. Flip the AC circuit breaker to the **off** position.
3. Open the cabinet door.
4. Disconnect main (line) power feeds on the power panel in the cabinet.
5. Flip all circuit breakers to the **off** position
6. Power **off** controller and signal heads before connecting the generator.
7. Remove the vent filter and pull the stripped female end of the extension cord through the vent louver and hook up power cord leads to the power panel in the cabinet.
8. Start the generator.
9. Plug in the male end of the extension cord to the generator.
10. Turn **on** cabinet circuit breakers, controller power and signal heads. The intersection should function normally. Visually check the intersection to verify proper operation.
11. Close and lock the cabinet door.
12. Depending on generator, refueling will be required every 4 to 8 hours.

(b) Disconnection Guidelines:

1. Verify that power has been restored.
2. Ensure that the main breaker at power service is still off.
3. Call law enforcement for traffic control during transfer back to line power.
4. Turn **off** the generator.
5. Open the cabinet door.
6. Power **off** the controller and signal heads.
7. Turn **off** all cabinet circuit breakers.
8. Detach the stripped female end of the extension cord from the power panel and reconnect main power leads.
9. Turn **on** the main breaker at the power service pole.

10. Turn **on** the cabinet circuit breakers.
11. Turn **on** controller power and signal heads. The intersection should function normally.
(Visually check the intersection to verify proper operation.)
12. Close and lock the cabinet door.



30 Amp Transfer Switch at Apalachee Parkway and Executive Center Drive

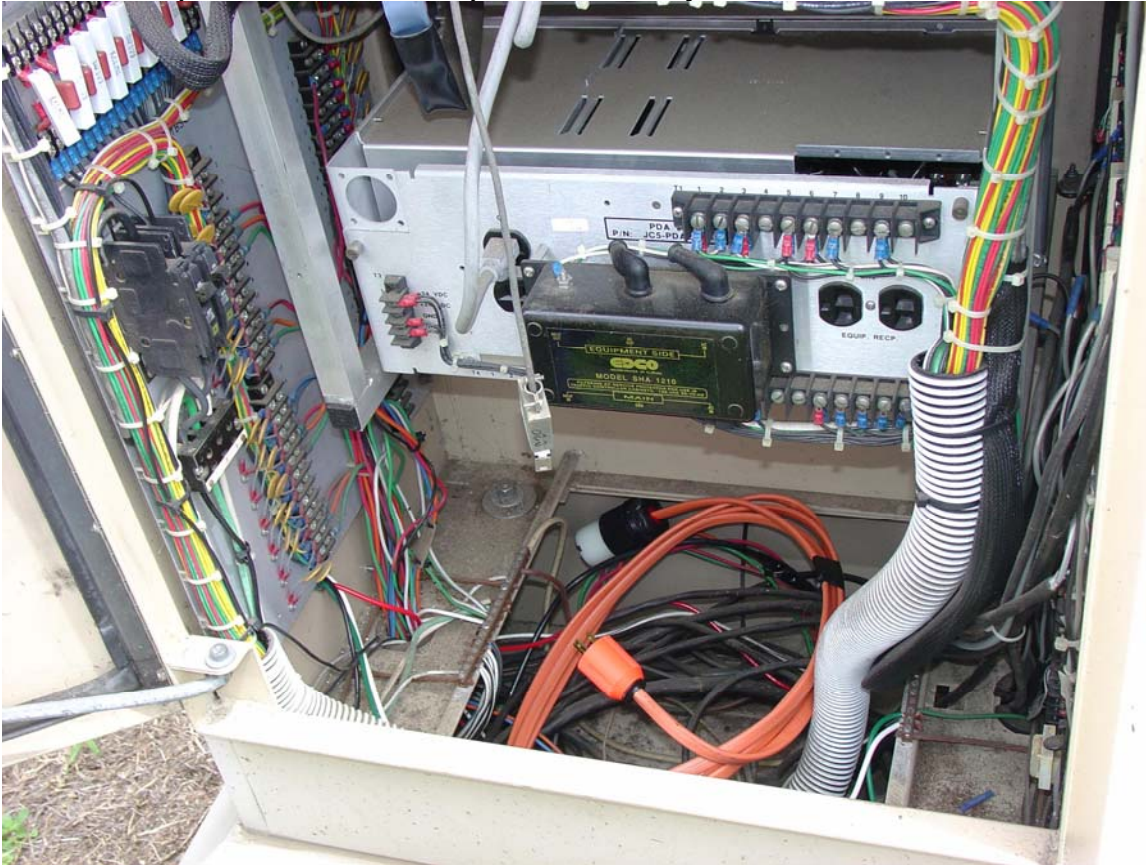

Generator cable stored in bottom of cabinet

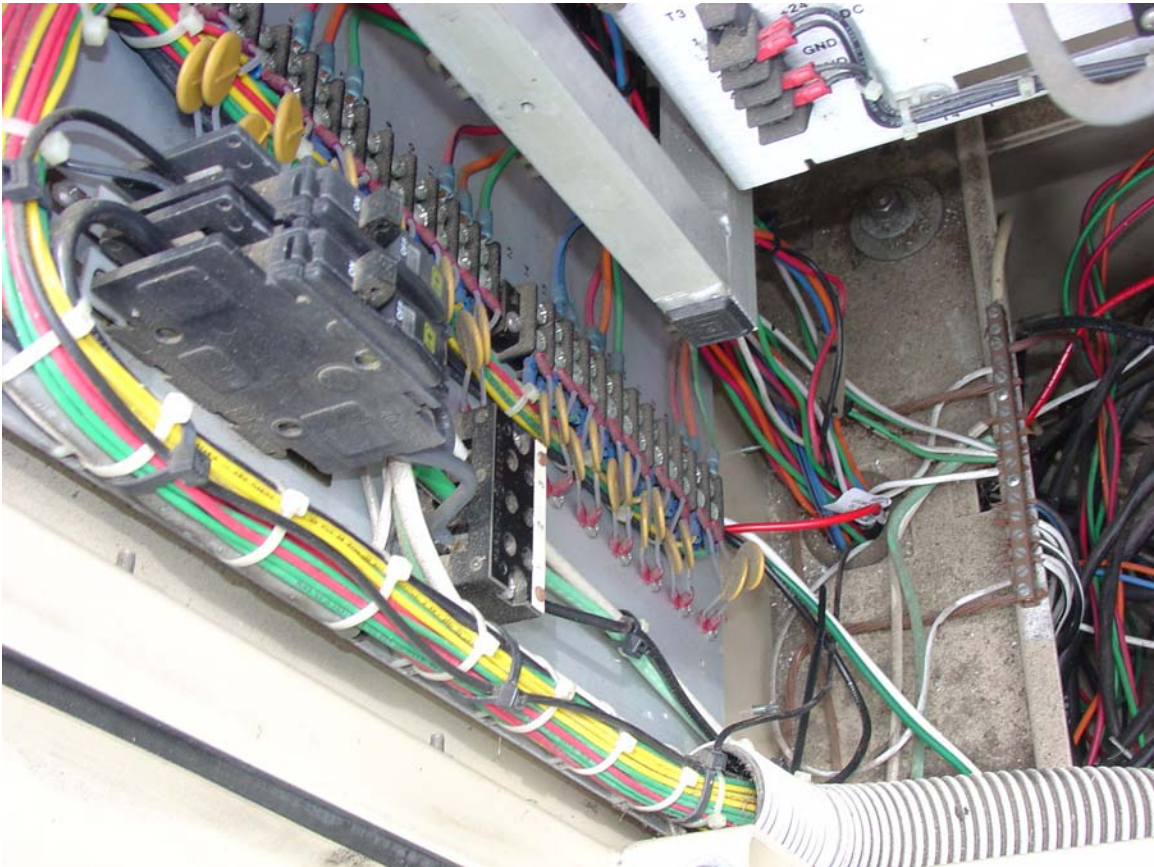

Black wire from transfer switch connected to AC + input terminal of cabinet

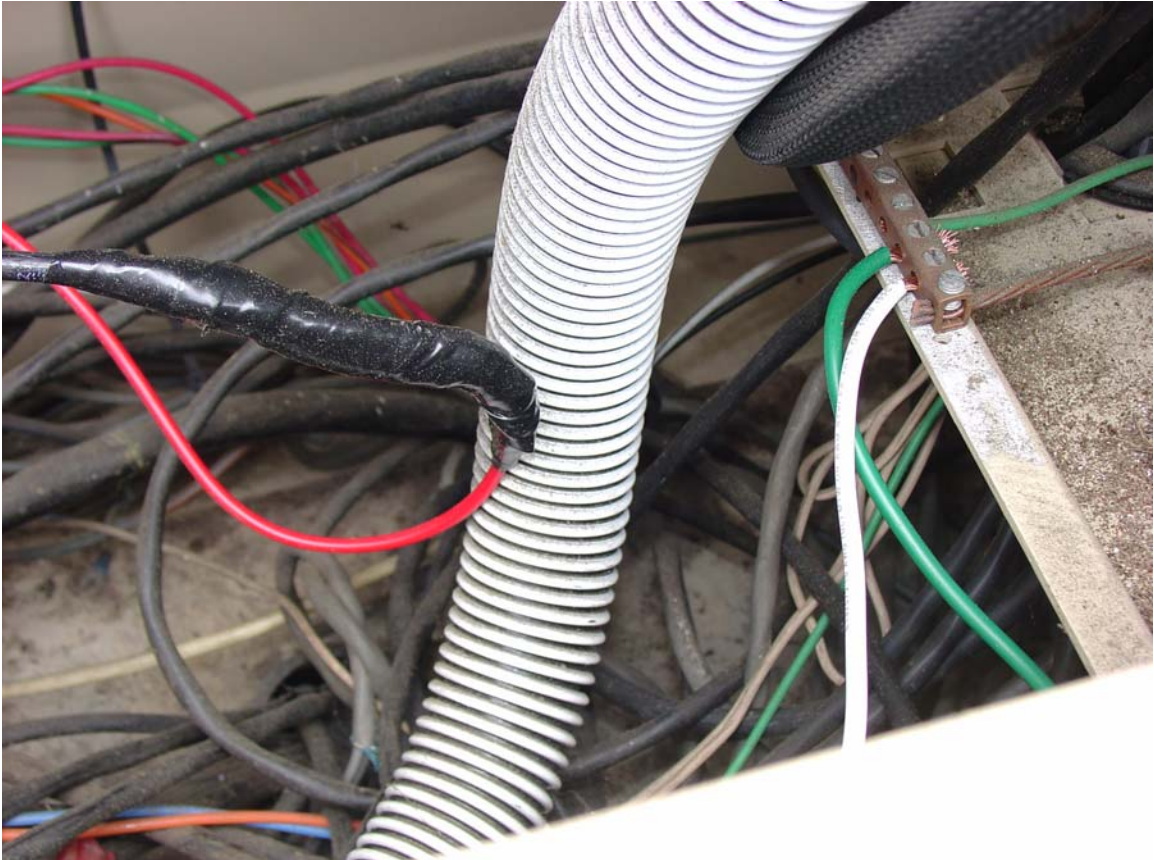

Red wire spliced to Service AC+, White and Green wires connected to cabinet buss bar



30 Amp Service at Apalachee Parkway and Executive Center Drive



Generator Cable Twist Lock Connector can be secured to transfer switch with pad lock.

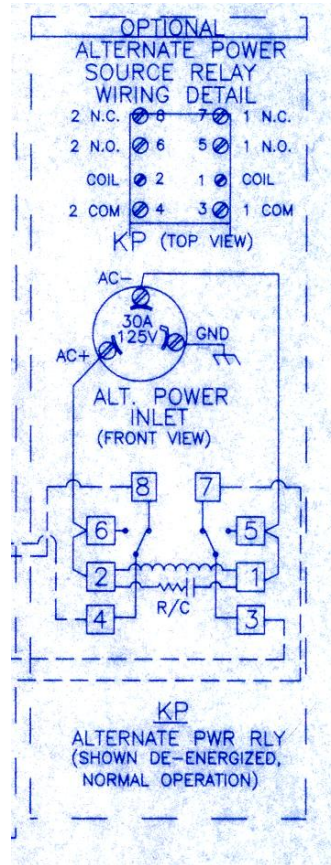

DCP_0562a.jpg



DCP_0563a.jpg



DCP_0564a.jpg

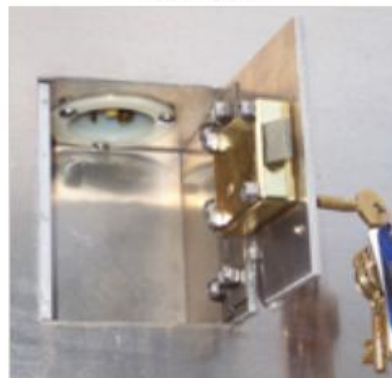

DCP_0565a.jpg

Automatic Transfer Switch and Generator Connection Panel