

NOTES:

1. Install DMS Foundation at location shown in Plans.
2. Extend Catwalk from DMS to outer edge of paved shoulder but not less than four feet in length.
3. If included, Install guardrail at location show in Plans and in accordance with Design Standards Index 400.

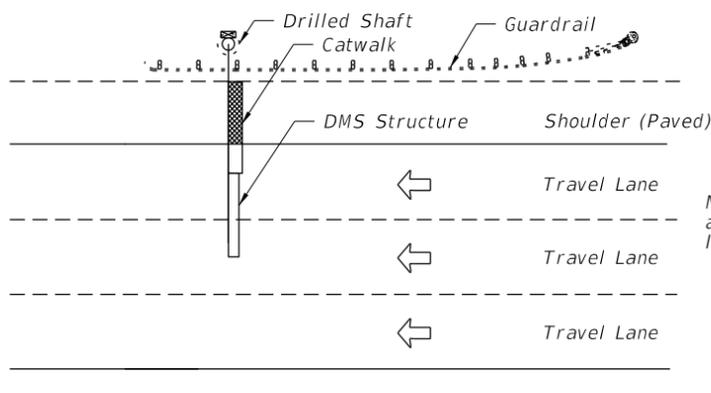

Note: Actual number and direction of travel lanes varies.

**TYPICAL PLAN VIEW
DMS CANTILEVER SIGN STRUCTURE**

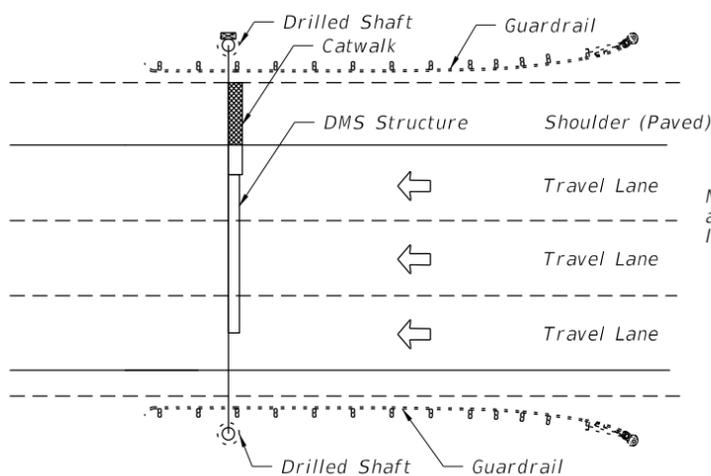

Note: Actual number and direction of travel lanes varies.

**TYPICAL PLAN VIEW
DMS SPAN SIGN STRUCTURE**

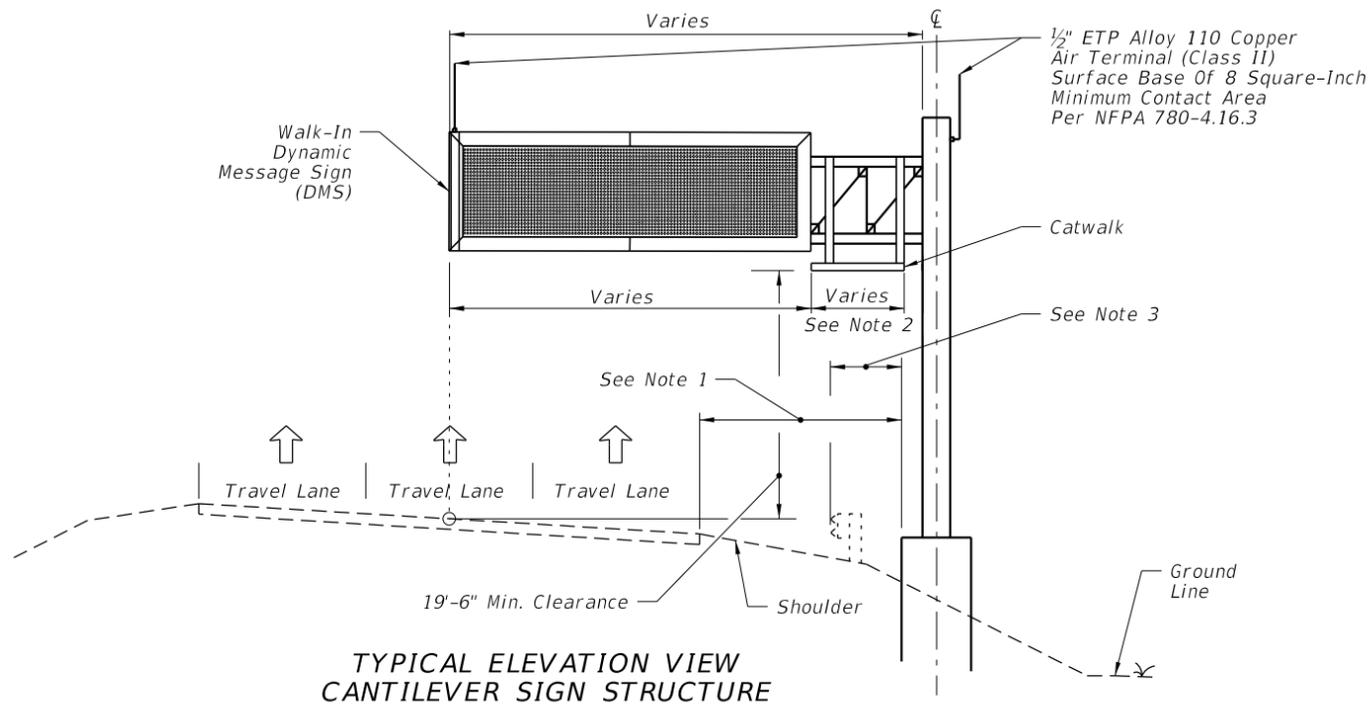

**TYPICAL ELEVATION VIEW
CANTILEVER SIGN STRUCTURE**

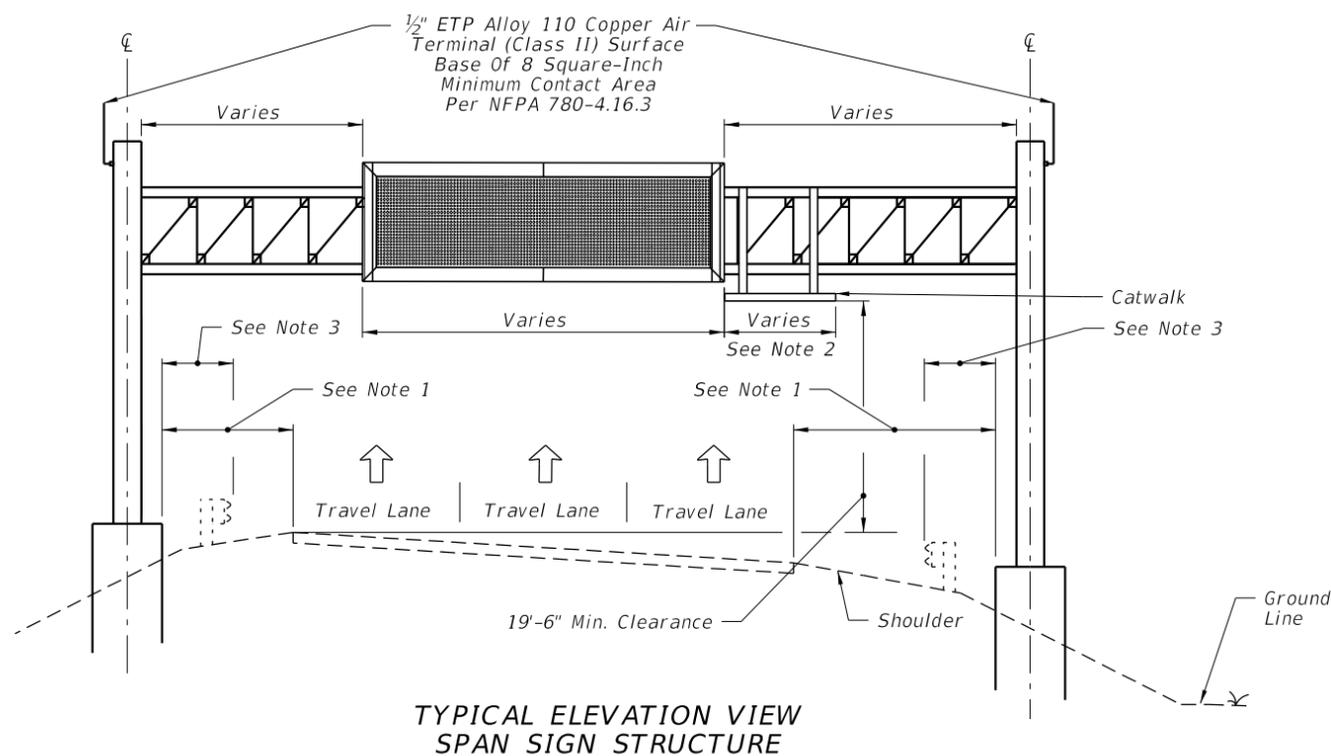

**TYPICAL ELEVATION VIEW
SPAN SIGN STRUCTURE**

GENERAL LAYOUT

10/11/2016 8:46:36 AM

LAST REVISION	DESCRIPTION:
07/01/15	



**FY 2017-18
DESIGN STANDARDS**

DYNAMIC MESSAGE SIGN WALK-IN

INDEX NO.
18300

SHEET NO.
1 of 9

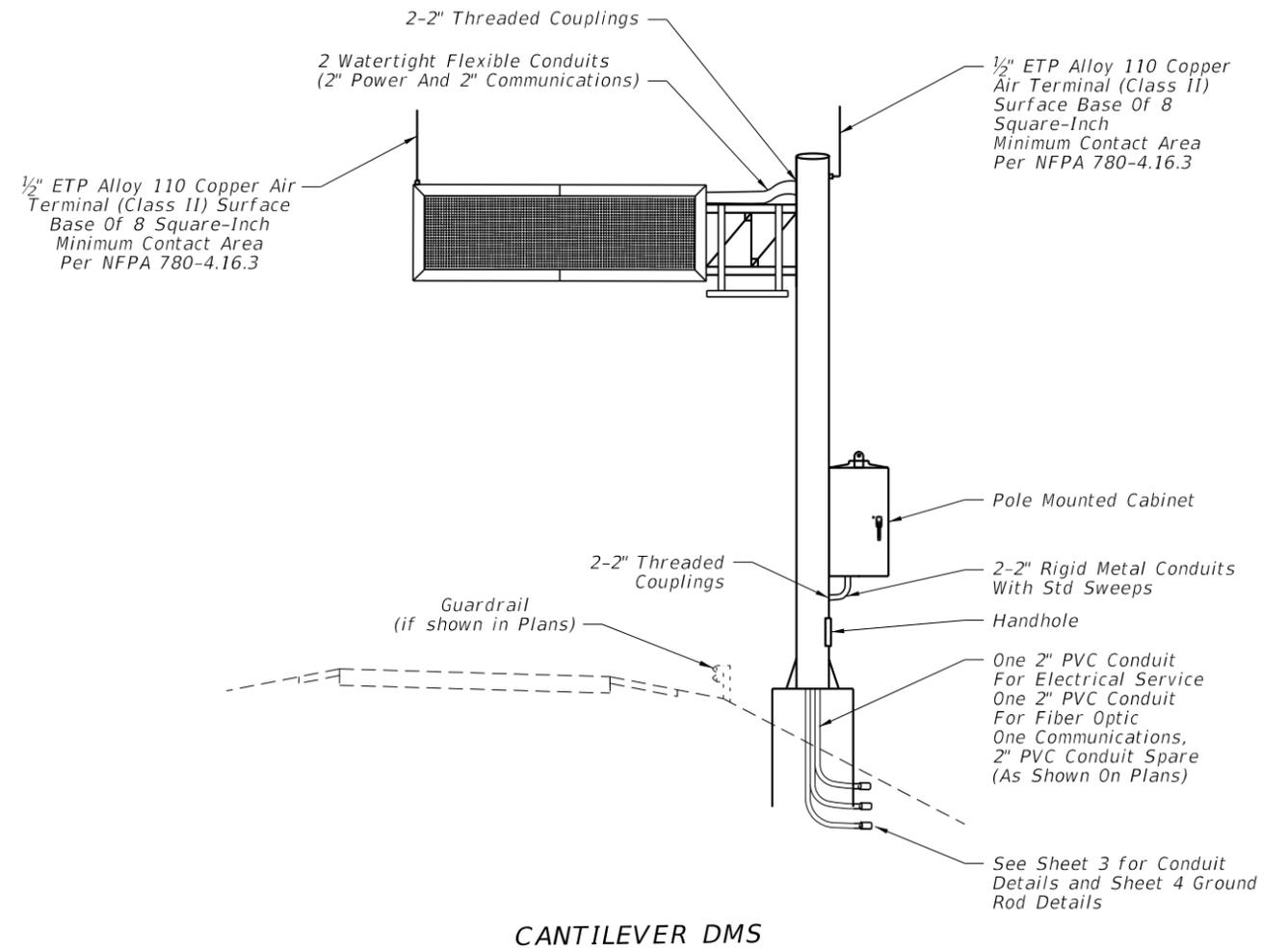
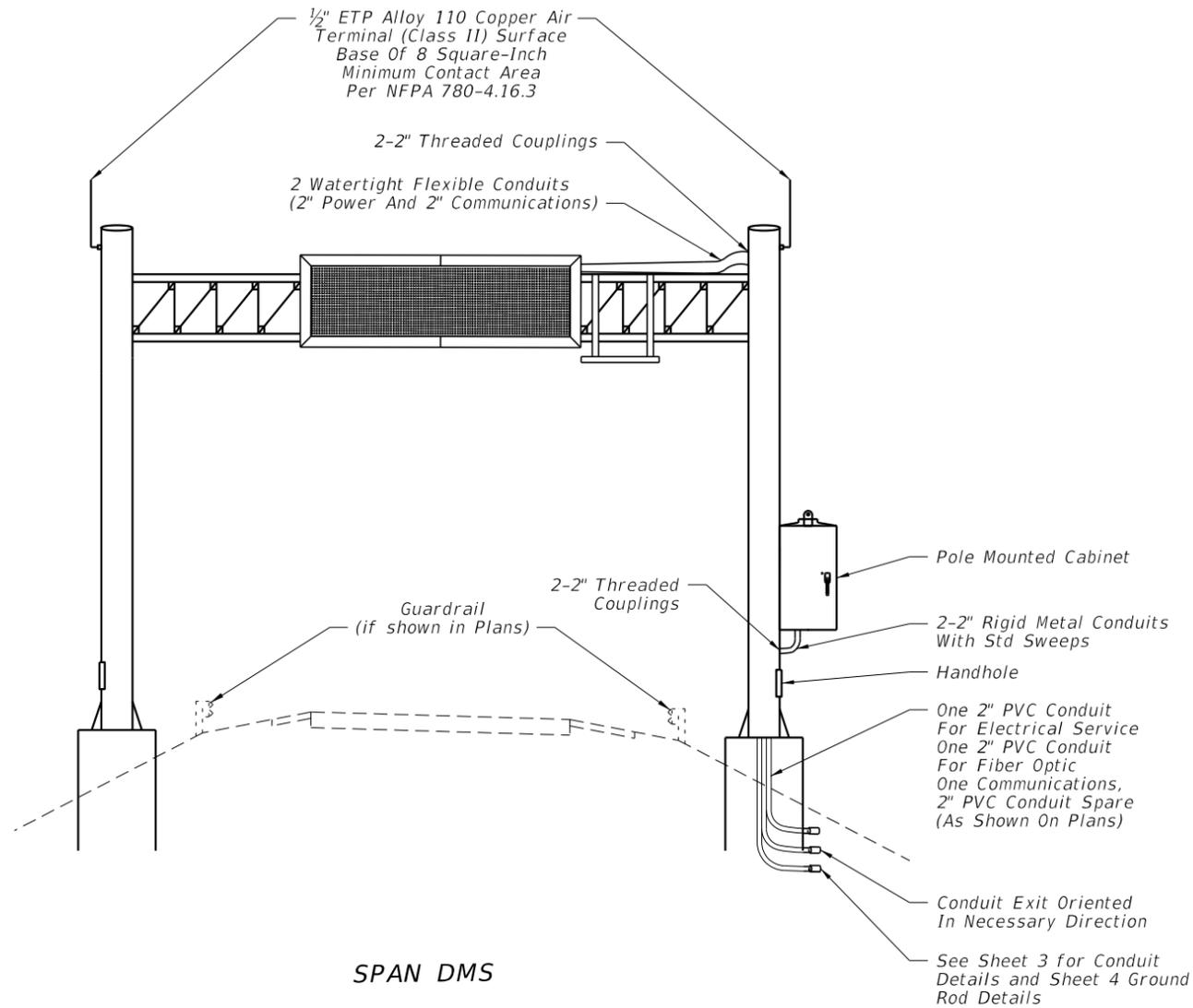

NOTES:

1. Conductors for grounding shall be connected to steel framework that has been cleaned to base metal by use of bonding plates having contact area of not less than 8 square inches or by welding or brazing. Drilling and tapping the steel structure to accept a threaded connector is also an acceptable method.
2. If steel framework is to be drilled and tapped to accept threaded connector, the threaded connector shall be galvanized and have at least 5 threads fully engaged and secured with a jam nut to the steel framework.
3. Bends in the conduit shall not be less than the minimum bending radius for the cable contained in the conduit.
4. Catwalk and handrail design and installation shall comply with AISC, AASHTO, and OSHA requirements as applicable.
5. All data, fiber optic and power cables for the DMS shall be completely encased within the sign structure or in conduit.
6. Permanently stamp/mark foundation to conduit locations.
7. Transition conduit in foundation to underground conduit with appropriate reducer outside the limits of the foundation.

10/11/2016 8:46:39 AM

LAST REVISION 07/01/15	REVISION	DESCRIPTION:	 FY 2017-18 DESIGN STANDARDS	DYNAMIC MESSAGE SIGN WALK-IN	INDEX NO. 18300	SHEET NO. 2 of 9
---------------------------	----------	--------------	--	-------------------------------------	---------------------------	----------------------------

NOTES:

1. DMS Cabinet may be pole or ground mounted depending on project requirements.
2. See sheet 4 for additional conduits for grounding. The number and placement of conduits are approximate.
3. Field adjust pole-mounted DMS cabinet height to achieve best access for maintenance personnel given site conditions as directed by the Engineer. Avoid conflicts with stiffeners, handhole and maintenance of anchor bolts.

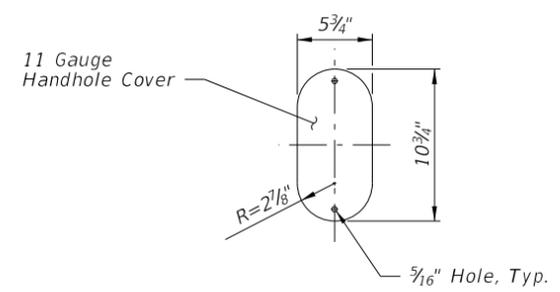
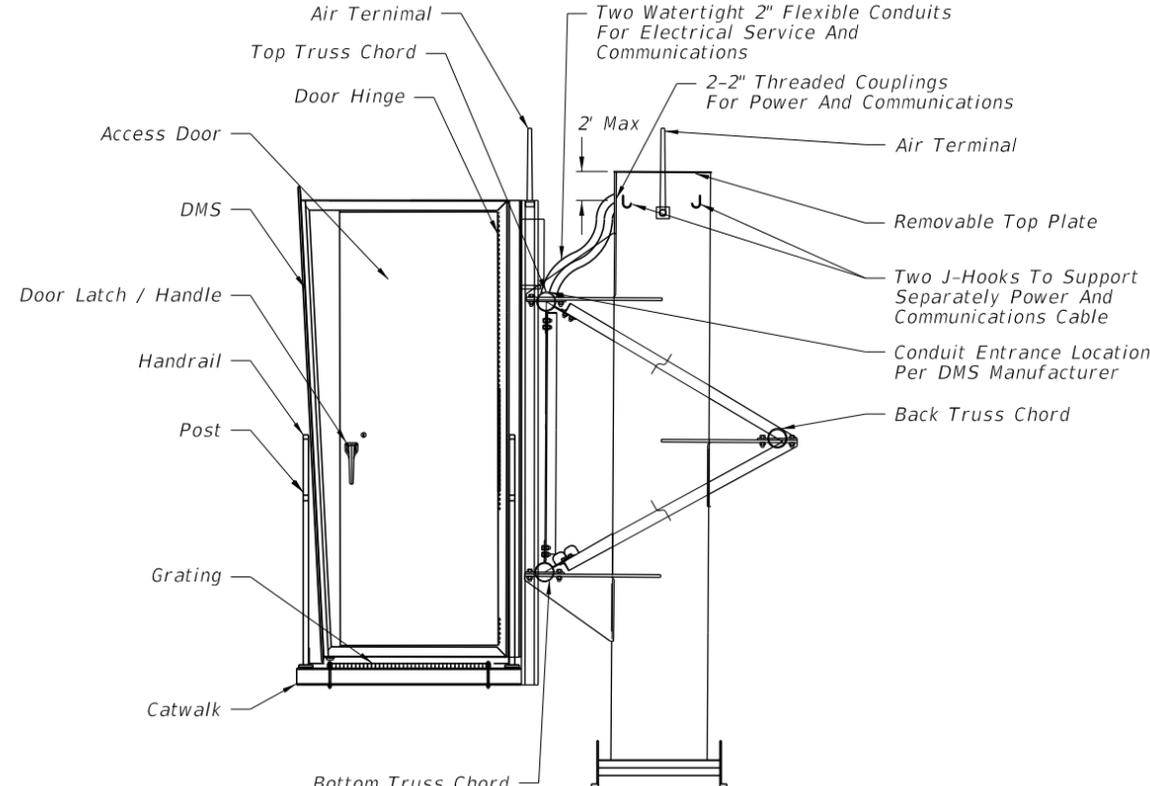

HANDHOLE COVER

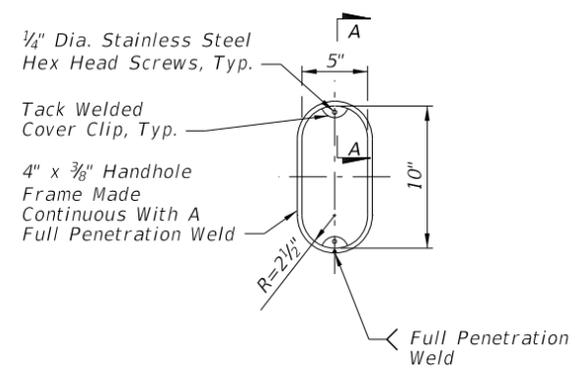

HANDHOLE FRAME

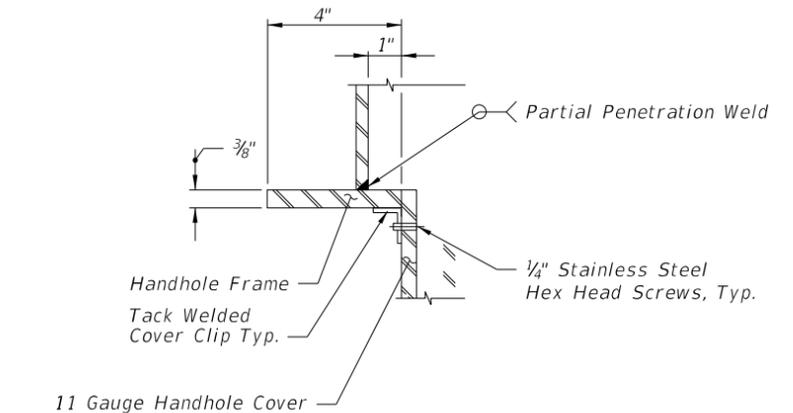

**SECTION A-A
(Thru Handhole)**

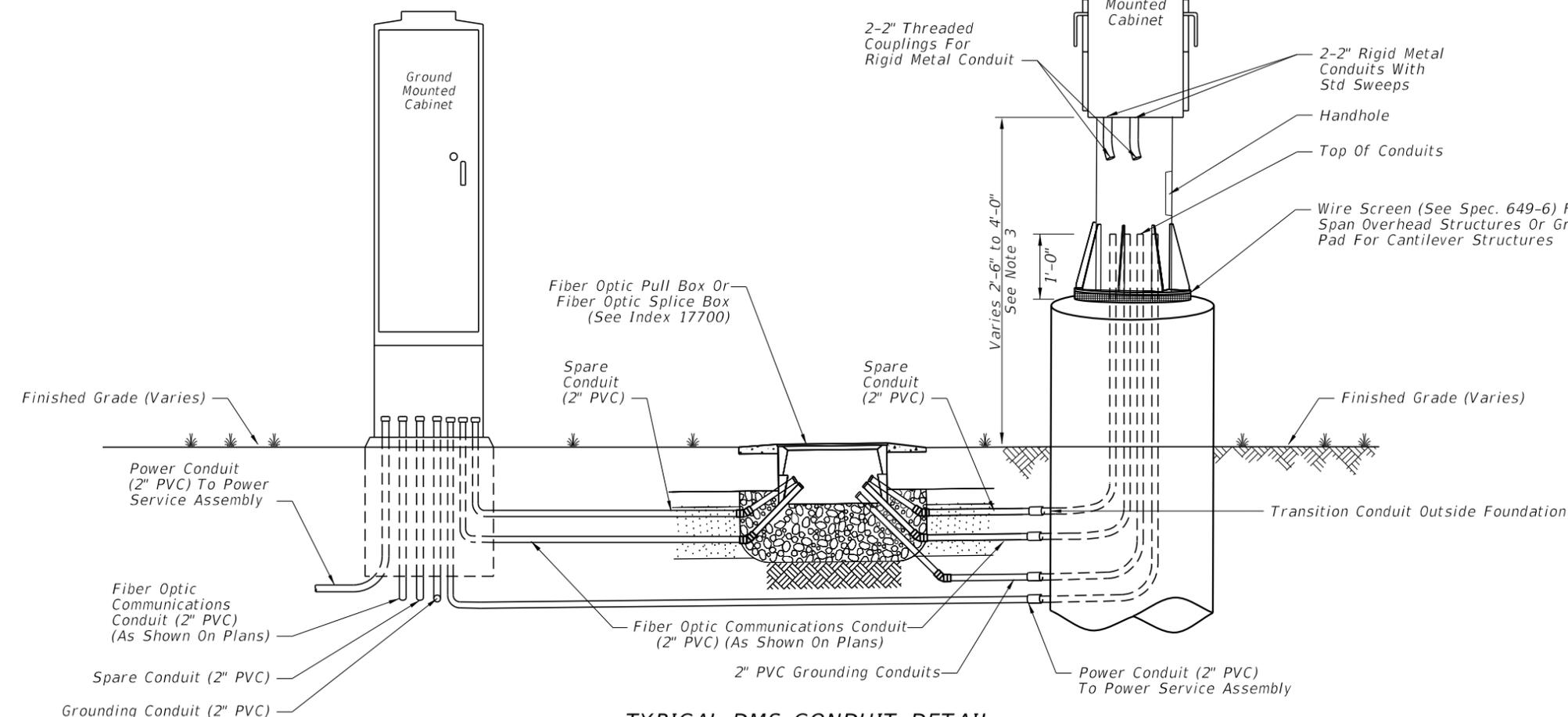

**TYPICAL DMS CONDUIT DETAIL
CANTILEVER/SPAN SIGN STRUCTURE**

10/11/2016 8:46:42 AM

LAST REVISION 11/01/16	DESCRIPTION:	 FY 2017-18 DESIGN STANDARDS	DYNAMIC MESSAGE SIGN WALK-IN	INDEX NO. 18300	SHEET NO. 3 of 9
---------------------------	--------------	--	-------------------------------------	---------------------------	----------------------------

1/2" ETP Alloy 110 Copper Air Terminal (Class II) Surface Base Of 8 Square-Inch Minimum Contact Area Per NFPA 780-4.16.3

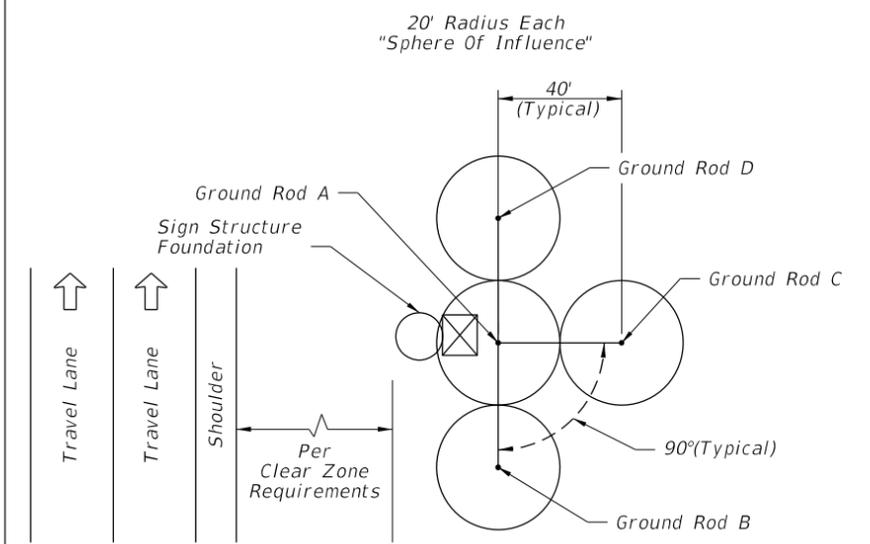
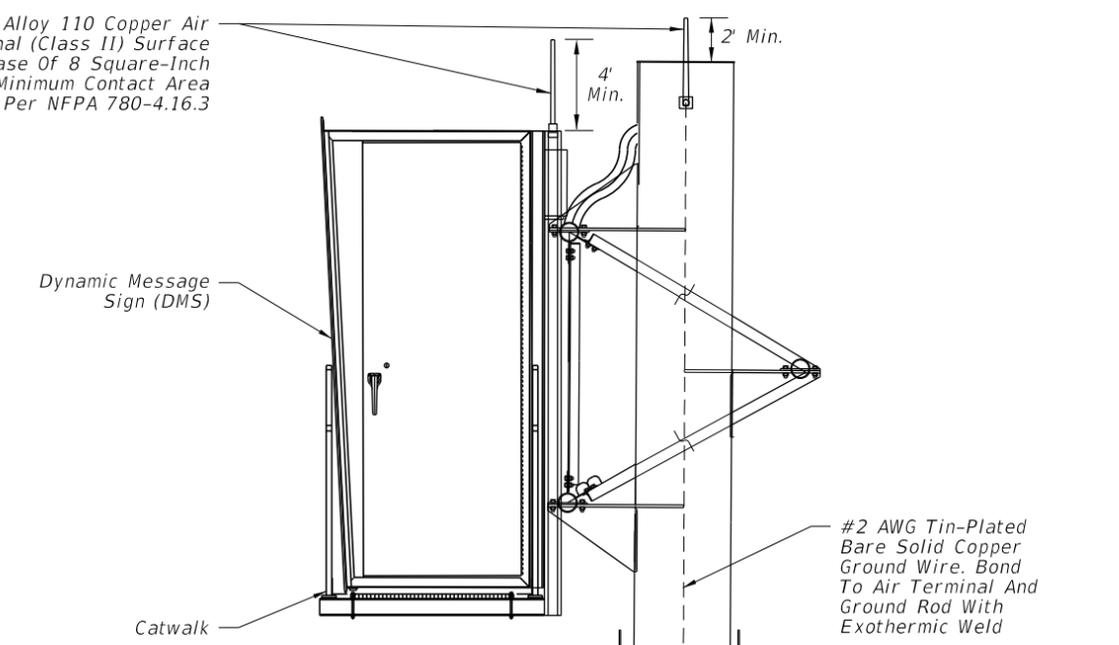

GROUND ROD PLACEMENT DETAIL (TYPICAL)

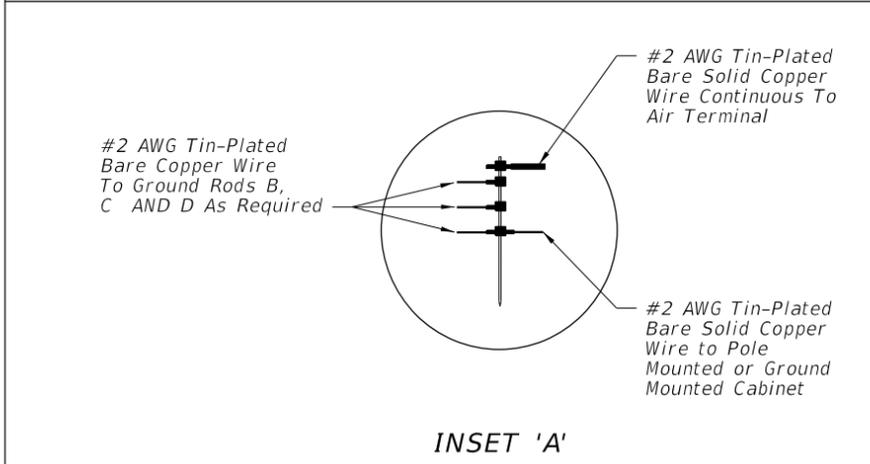

INSET 'A'

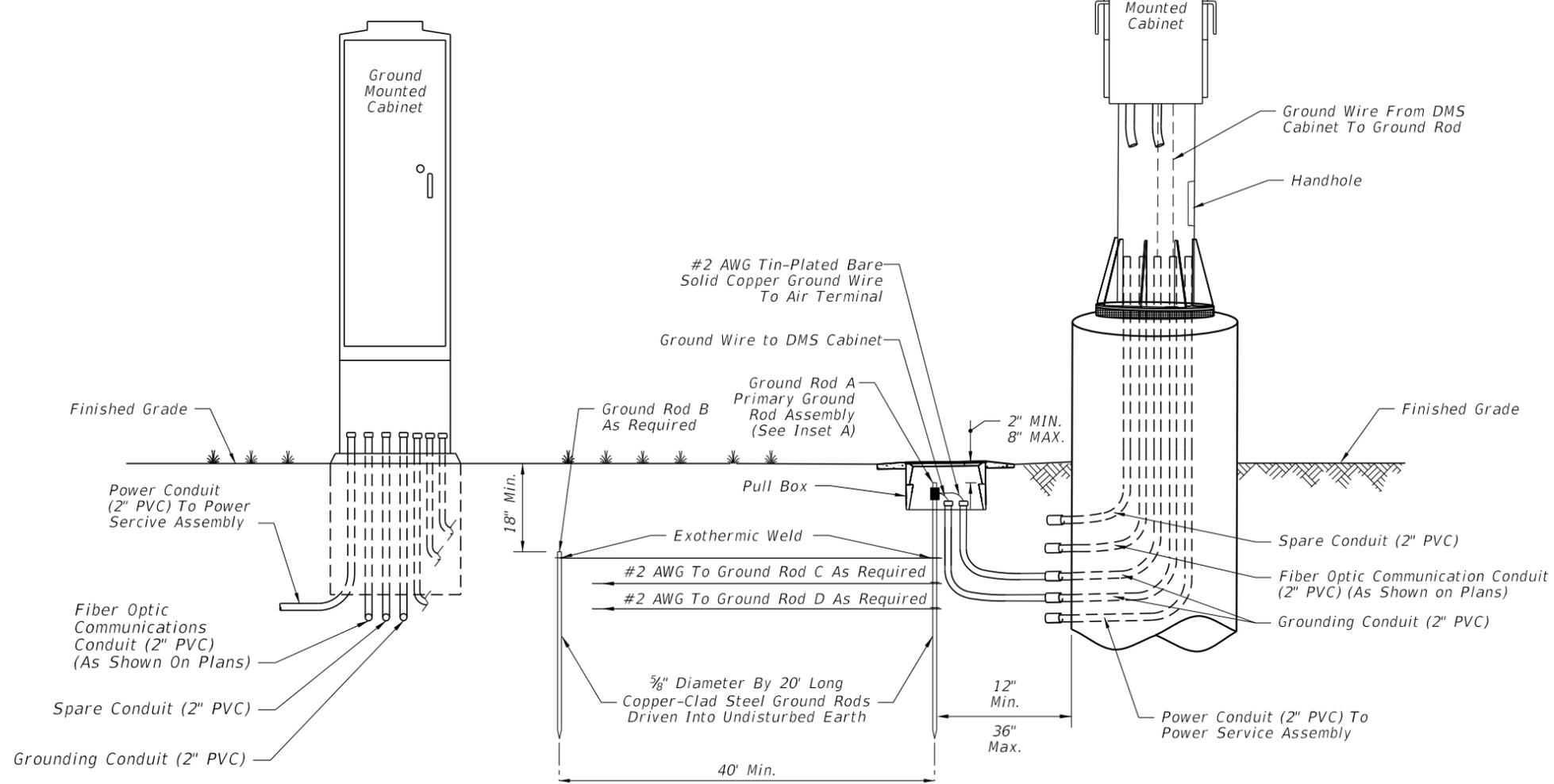

TYPICAL GROUND ROD DETAIL

10/11/2016 8:46:45 AM

LAST REVISION 11/01/16	REVISION	DESCRIPTION:	FY 2017-18 DESIGN STANDARDS	DYNAMIC MESSAGE SIGN WALK-IN	INDEX NO. 18300	SHEET NO. 4 of 9
---------------------------	----------	--------------	--	-------------------------------------	---------------------------	----------------------------

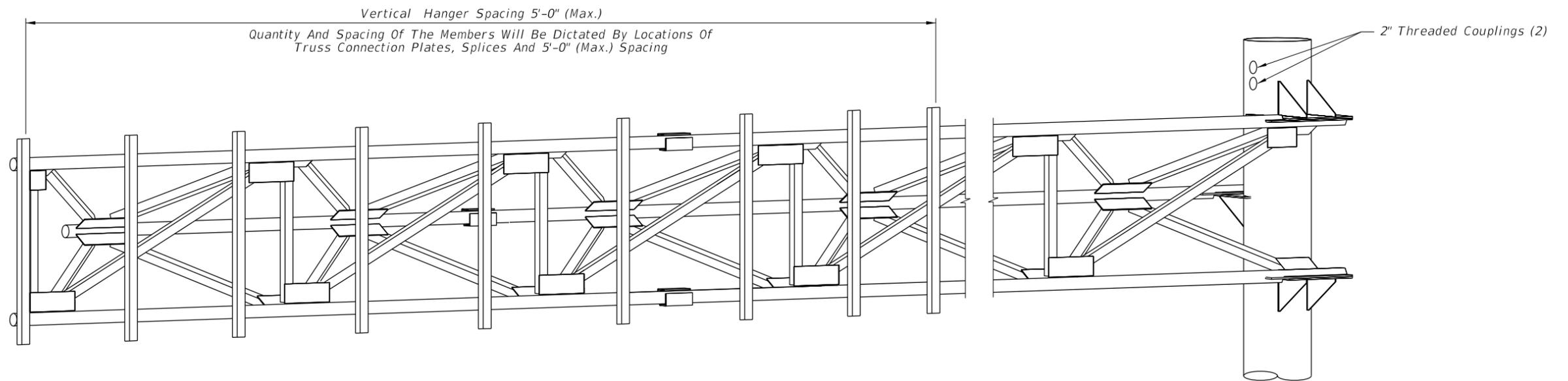

HANGER LOCATION DETAIL

(Cantilever Sign Structure Shown, Span Sign Structure Similar)

NOTES

1. Design Specifications: FDOT Structures Manual (current edition) and AASHTO Standard Specifications for Structural Supports for Highway Signs, Luminaires and Traffic Signals.
2. DMS and Hanger Design Wind Speed: 150 miles per hour. Maximum DMS weight for design: 4500 lb.
3. Support Structure Design Wind Speed: See Structures Manual.
4. Shop drawings including the DMS connection are required and fabrication shall not begin until these shop drawings are approved.
5. Locate the sign horizontal on the structure as shown in the plans. Vertically center the sign enclosure with the centerline of the truss.
6. Before erection, after both the delivery of the DMS and the steel truss, the contractor shall carefully measure the exact locations for field drilling the b" bolt holes in the vertical hangers and horizontal mounting member attached to the sign enclosure. Field locate holes to allow vertical hanger placement as shown on the plans with no conflicts with gusset or splice plates.
7. All steel items shall be galvanized as follows:
All nuts, bolts and washers ASTM F2329
All other steel items ASTM A123
8. All bolt holes shall be equal to the bolt diameter plus $\frac{1}{16}$ ", prior to galvanizing.
9. Cost of the installation of the DMS on truss including the vertical hanger, associated members, and hardware shall be incidental to the cost of the sign structure.
10. Threaded couplings shall be located on sign side of column above the sign truss.

10/18/2016 8:20:17 AM

LAST REVISION 11/01/16	REVISION	DESCRIPTION:	FY 2017-18 DESIGN STANDARDS	DYNAMIC MESSAGE SIGN WALK-IN	INDEX NO. 18300	SHEET NO. 5 of 9
------------------------------	----------	--------------	--	-------------------------------------	------------------------------	-------------------------------

6061-T6 Structural Aluminum Zee 4x3 $\frac{1}{8}$ x3.58
Horizontal Member Attached To The Internal
Framework And Included With The DMS Sign

DMS Sign Enclosure

ASTM A709, Gr.36 Steel W6x9
Hanger @ 5' (Max.) Spacing

2- $\frac{1}{2}$ " \varnothing U-Bolts ASTM F2329,
Grade A449 Or A193 B7,
Galvanized With double
Nuts and Washers

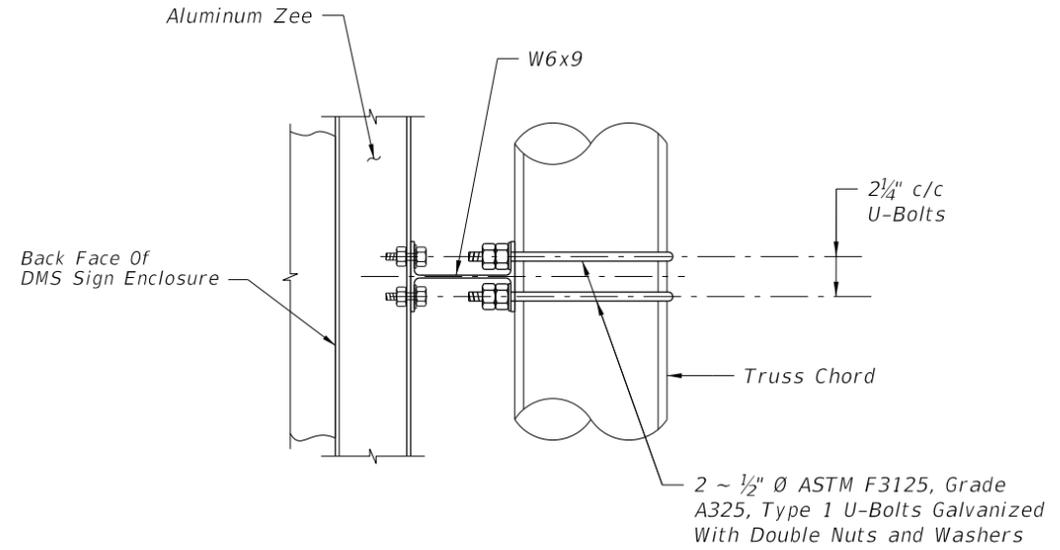

SECTION A-A

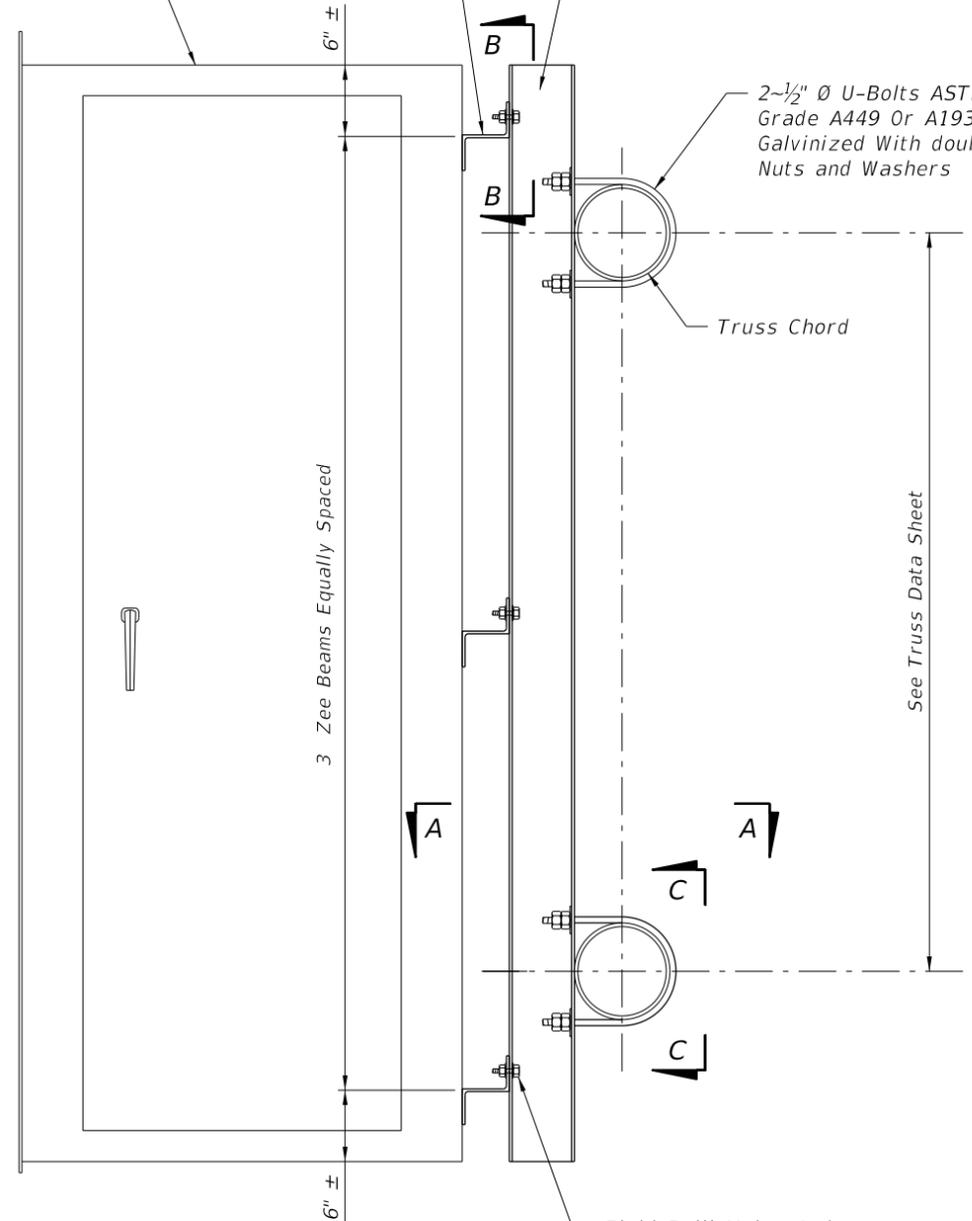

END VIEW

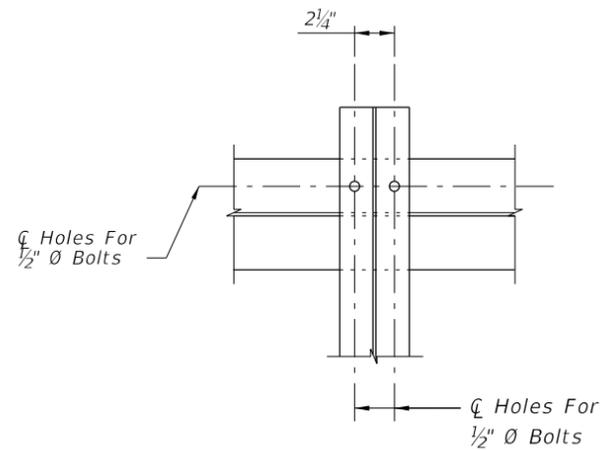

SECTION B-B

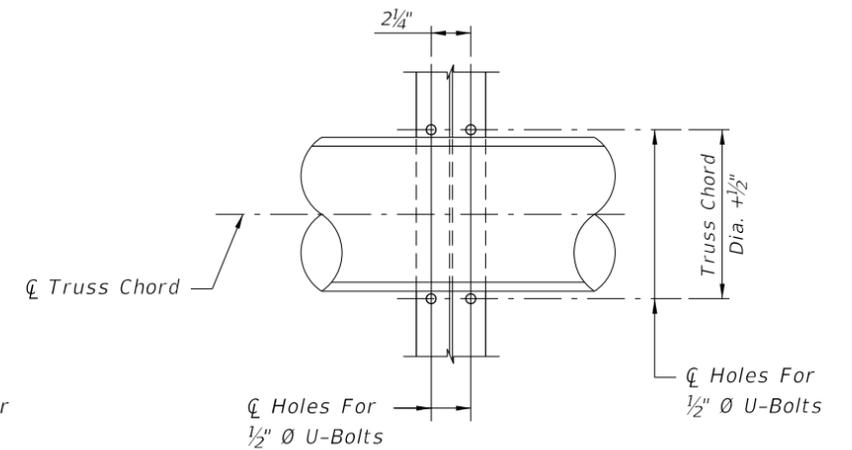

SECTION C-C

Field Drill Holes And
Provide 2 ~ $\frac{1}{2}$ " \varnothing ASTM
F3125, Grade A325, Type 1

See Truss Data Sheet

3 Zee Beams Equally Spaced

6" \pm

6" \pm

10/11/2016 8:46:50 AM

LAST REVISION 11/01/16	DESCRIPTION:
---------------------------	--------------

FDOT FY 2017-18
DESIGN STANDARDS

DYNAMIC MESSAGE SIGN WALK-IN

INDEX NO.
18300

SHEET NO.
6 of 9

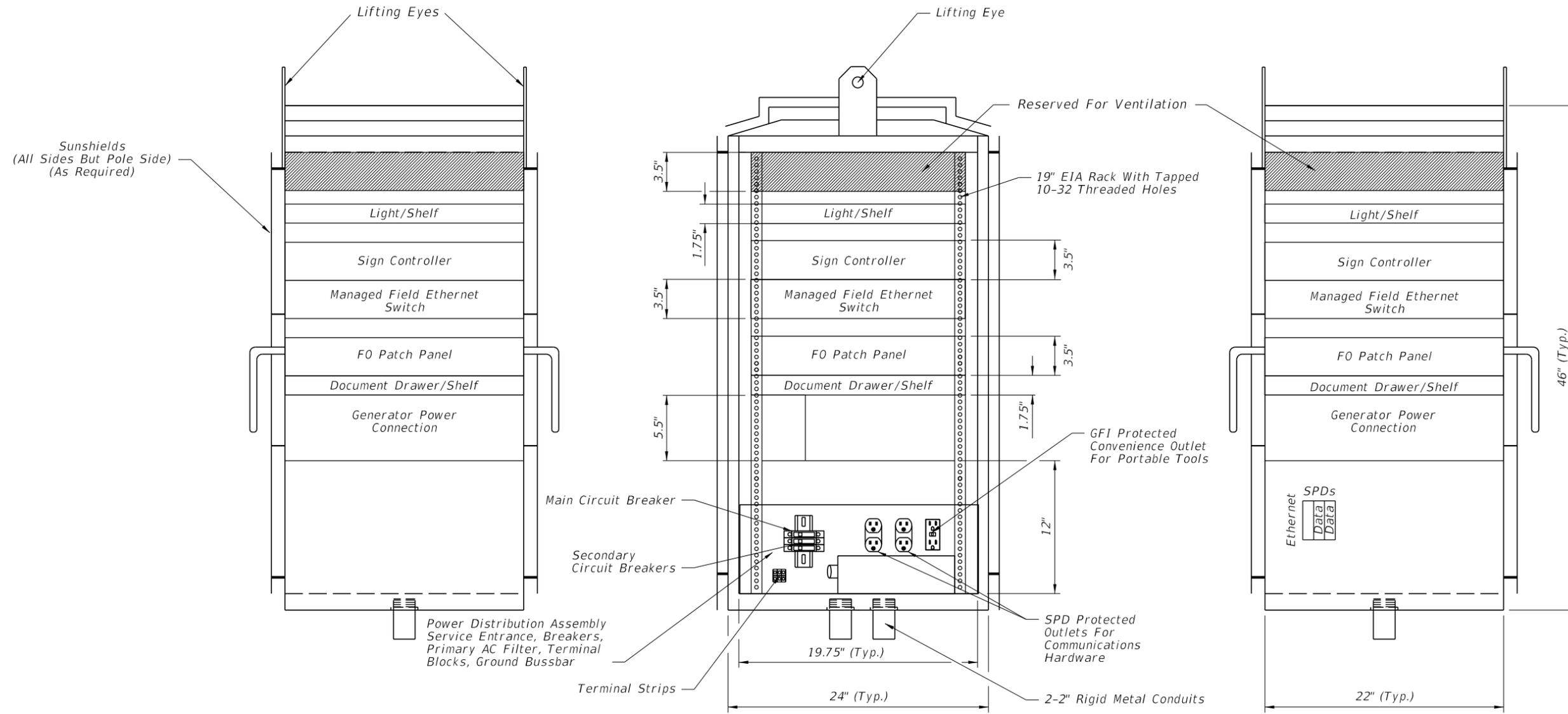

NOTES:

1. Cabinet layout is for pole or ground mounted installations.
2. All dimensions and equipment locations are approximate.
3. Conduit entrances are at bottom of cabinet.
4. Minimum number of duplex outlets is three, (2) SPD protected and (1) GFI protected.
5. Either an access controller or local access panel shall be provided to provide full access to DMS for control, programming and troubleshooting.
6. Load center shall be sized for connected equipment and convenience outlets with at least one main disconnect and three circuit breakers.
7. Batteries and UPS may be located in sign housing or cabinet.
8. Power Distribution Assembly component layout, orientation and location may vary.

CABINET LAYOUT 1

10/11/2016 8:46:56 AM

LAST REVISION 07/01/14	REVISION	DESCRIPTION:	 FY 2017-18 DESIGN STANDARDS	DYNAMIC MESSAGE SIGN WALK-IN	INDEX NO. 18300	SHEET NO. 8 of 9
---------------------------	----------	--------------	--	-------------------------------------	---------------------------	----------------------------

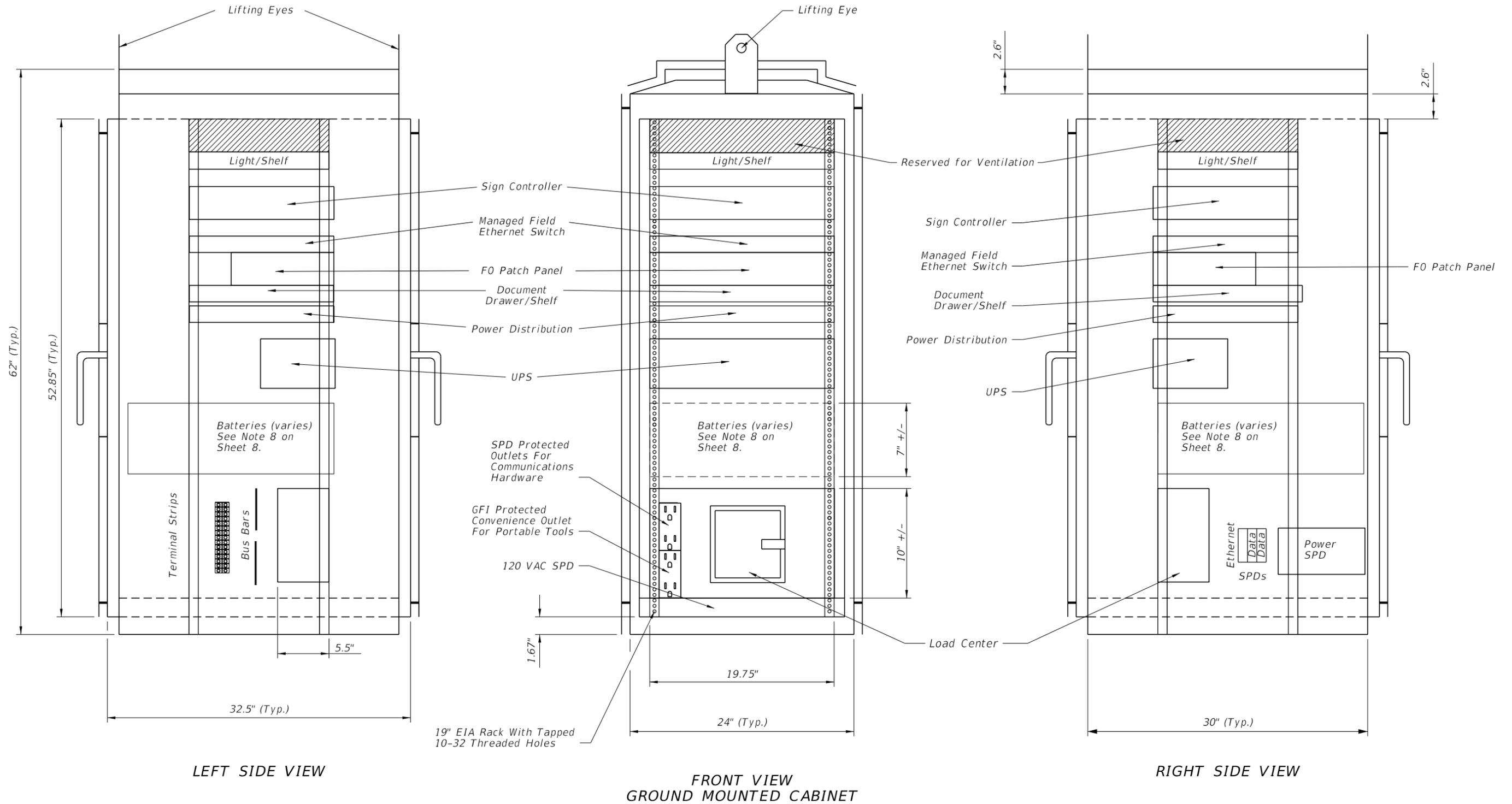

10/11/2016 8:46:59 AM

CABINET LAYOUT 2

LAST REVISION 07/01/14	REVISION	DESCRIPTION:	 FY 2017-18 DESIGN STANDARDS	DYNAMIC MESSAGE SIGN WALK-IN	INDEX NO. 18300	SHEET NO. 9 of 9
---------------------------	----------	--------------	--	-------------------------------------	---------------------------	----------------------------