

PLAN VIEW (CASE 1)

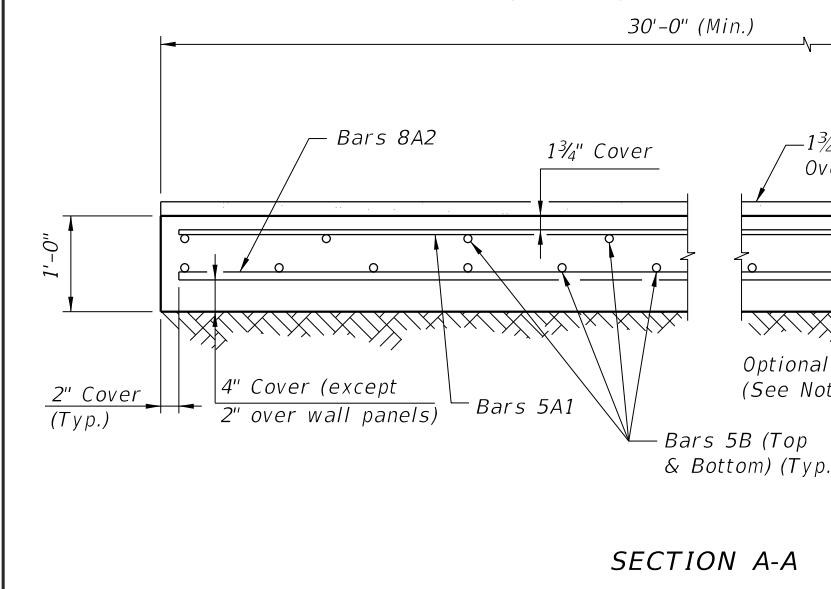

SECTION A-A

* NOTE: Bars 5C are required as shown when either the 32" or 42" F-Shape Traffic Railings or the Traffic Railing/Noise Wall are used at the edge of the Approach Slab.

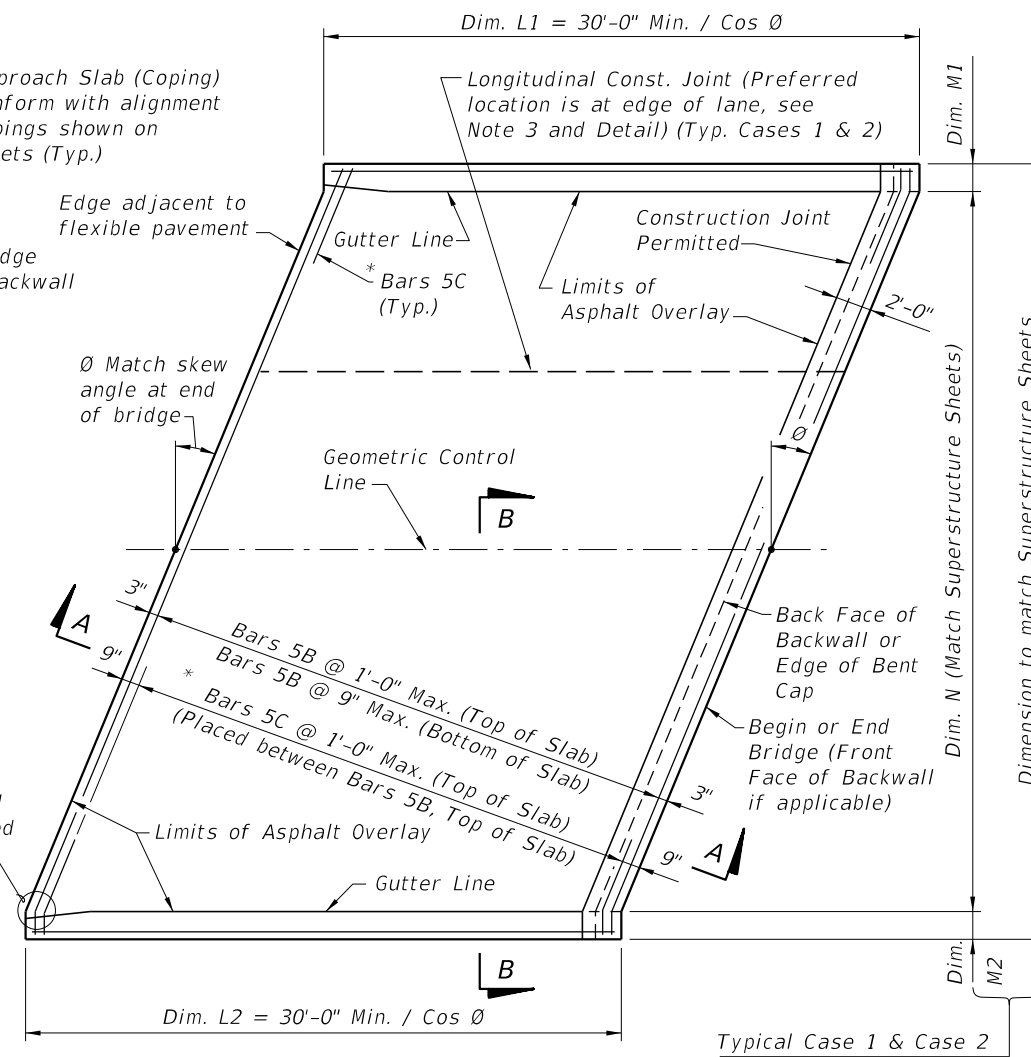

PLAN VIEW (CASE 2)

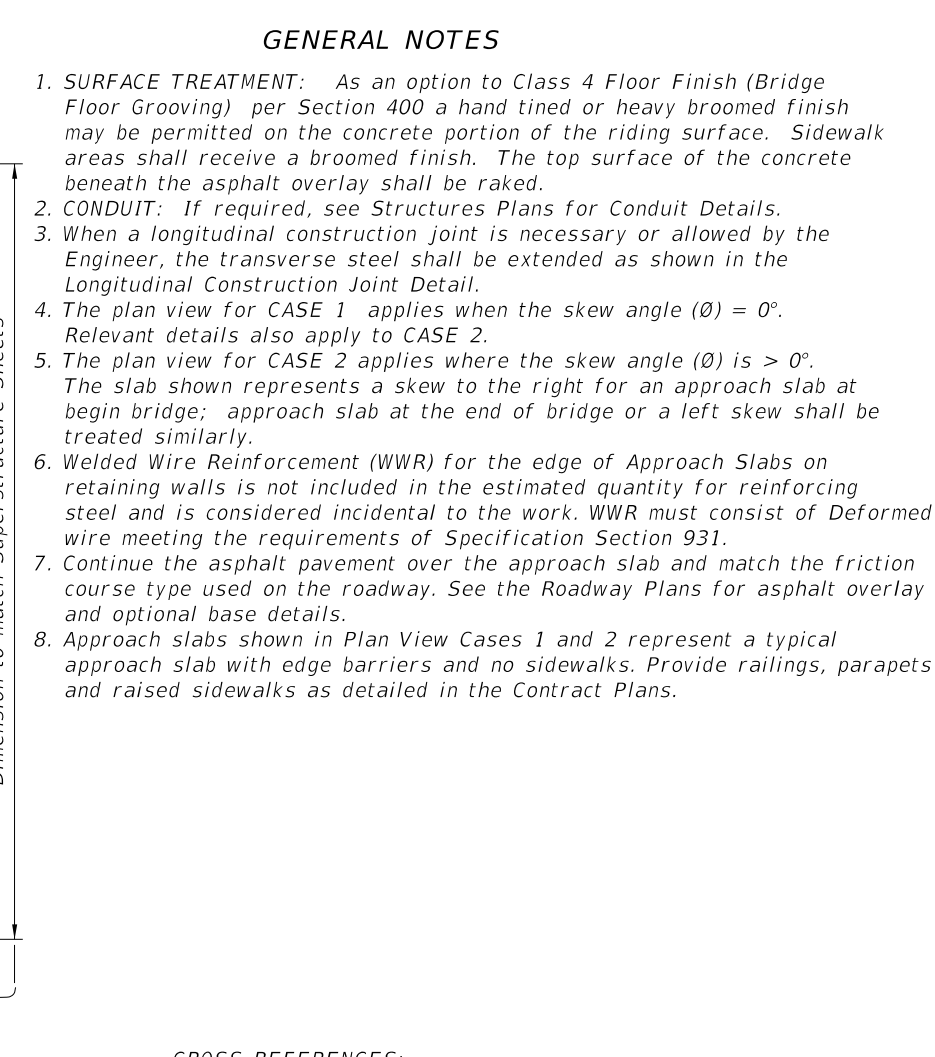

CROSS REFERENCES:

For Section B-B, Longitudinal Construction Joint Detail and Approach Slab Details see Sheet 2.

12/17/2015 1:45:48 PM

LAST REVISION 07/01/14	REVISION	DESCRIPTION:	 FY 2016-17 DESIGN STANDARDS	APPROACH SLABS (FLEXIBLE PAVEMENT APPROACHES)	INDEX NO. 20900	SHEET NO. 1 of 2
---------------------------	----------	--------------	------------------------------------	--	--------------------	---------------------

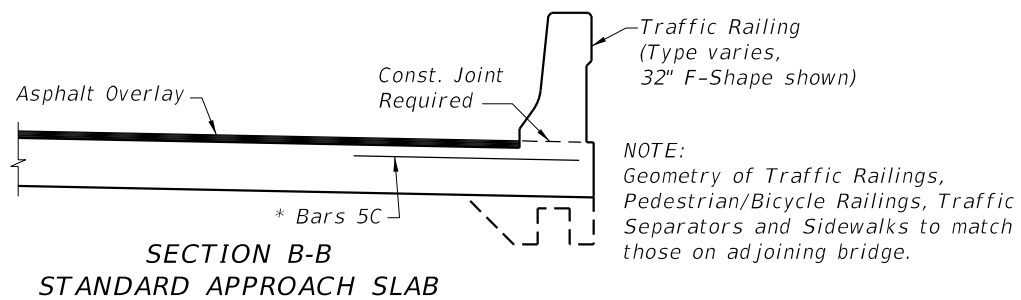

**SECTION B-B
STANDARD APPROACH SLAB**

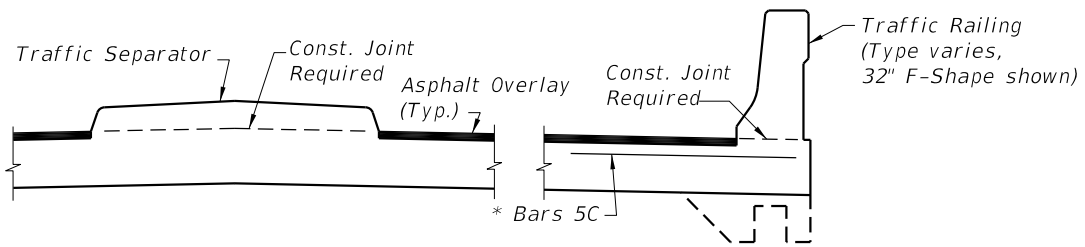

**SECTION B-B
APPROACH SLAB WITH TRAFFIC SEPARATOR**

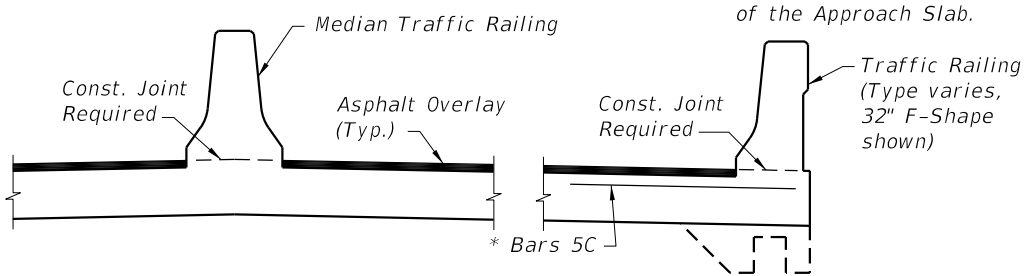

**SECTION B-B
APPROACH SLAB WITH MEDIAN TRAFFIC RAILING**

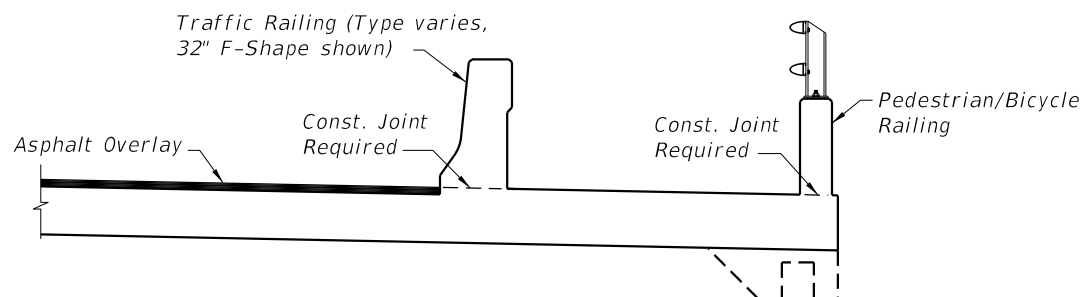

**SECTION B-B
APPROACH SLAB WITH SIDEWALK**

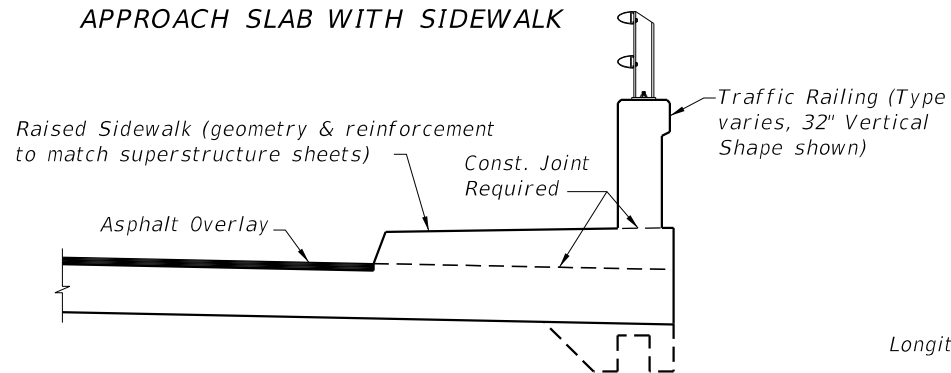

**SECTION B-B
APPROACH SLAB WITH RAISED SIDEWALK**

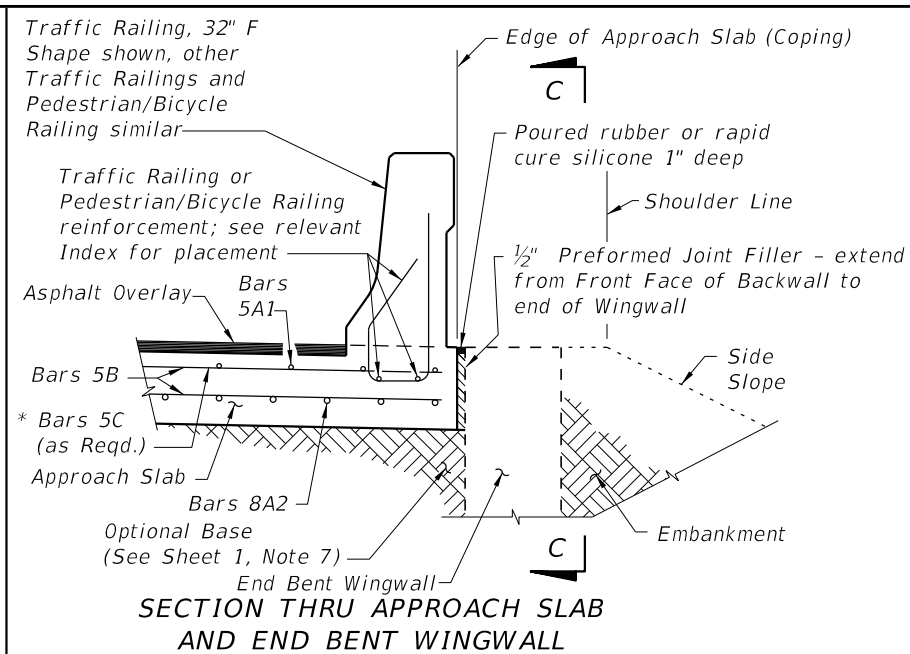

**SECTION THRU APPROACH SLAB
AND END BENT WINGWALL**

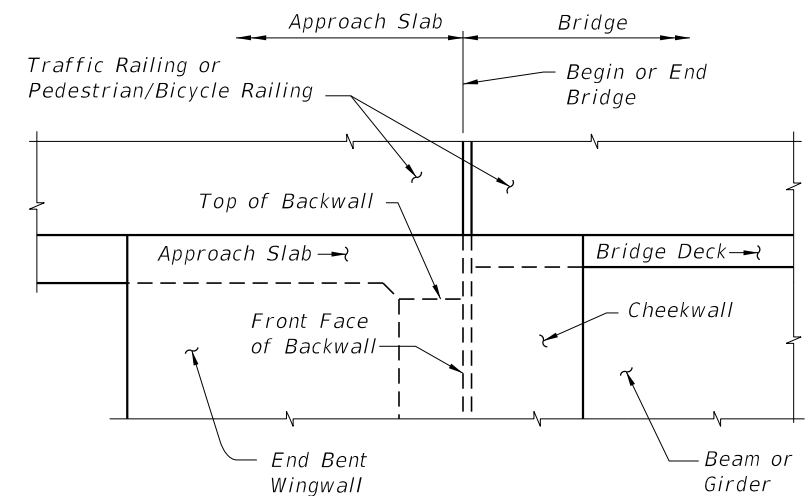

**VIEW C-C AT BEGIN OR END BRIDGE (BEAM
BRIDGE SHOWN, FLAT SLAB BRIDGE SIMILAR)**

APPROACH SLAB WITH WINGWALL DETAILS

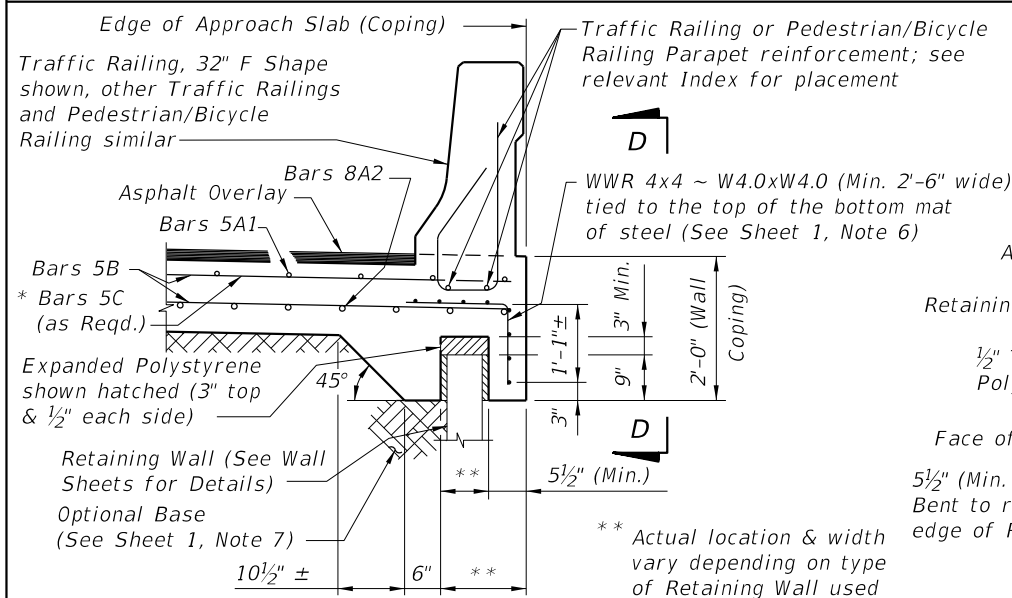

**SECTION THRU APPROACH SLAB
AND RETAINING WALL**

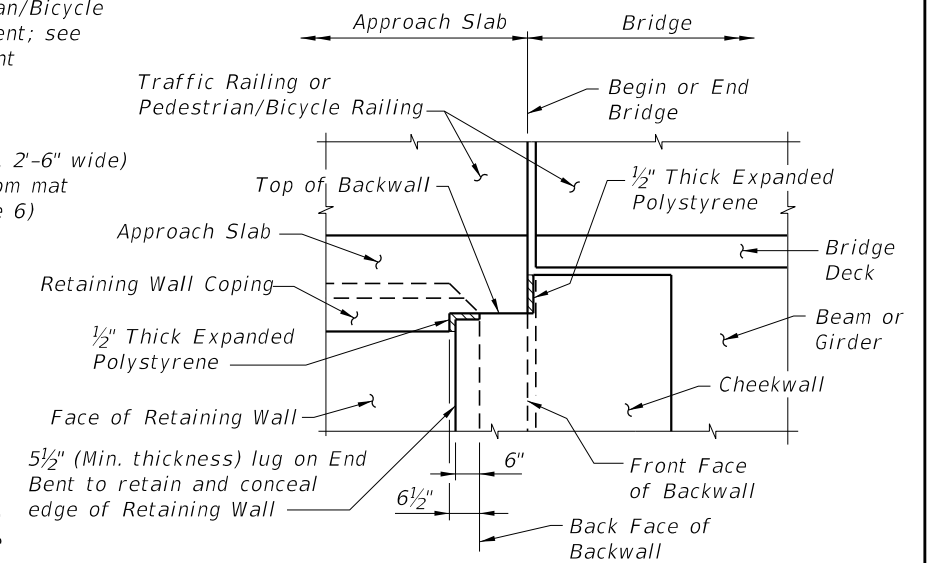

**VIEW D-D AT BEGIN OR END BRIDGE (BEAM
BRIDGE SHOWN, FLAT SLAB BRIDGE SIMILAR)**

APPROACH SLAB WITH RETAINING WALL DETAILS

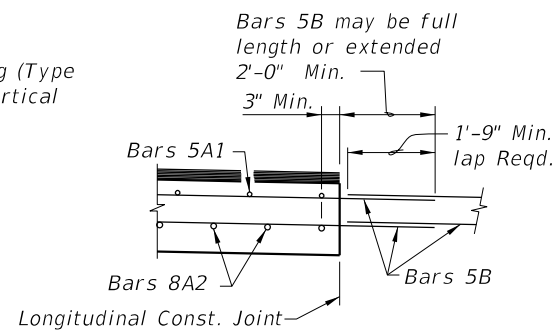

**LONGITUDINAL CONSTRUCTION
JOINT DETAIL**

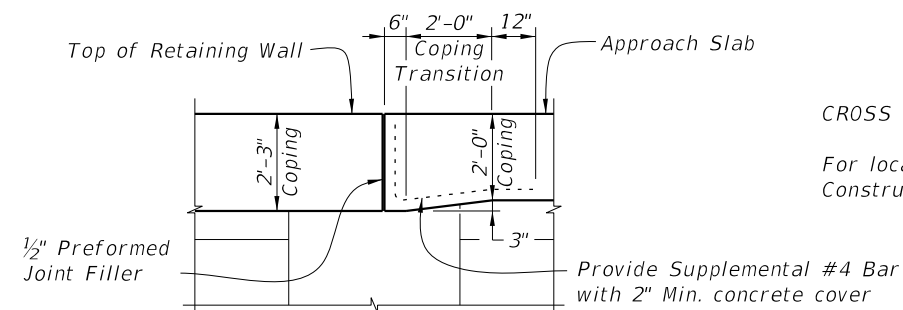

**COPING TRANSITION DETAIL FOR
RETAINING WALLS WITH 2'-3\"/>**

CROSS REFERENCES:

For location of Section B-B and Longitudinal Construction Joint see Sheet 1.

12/17/2015 1:45:49 PM

LAST REVISION	DESCRIPTION:
07/01/14	

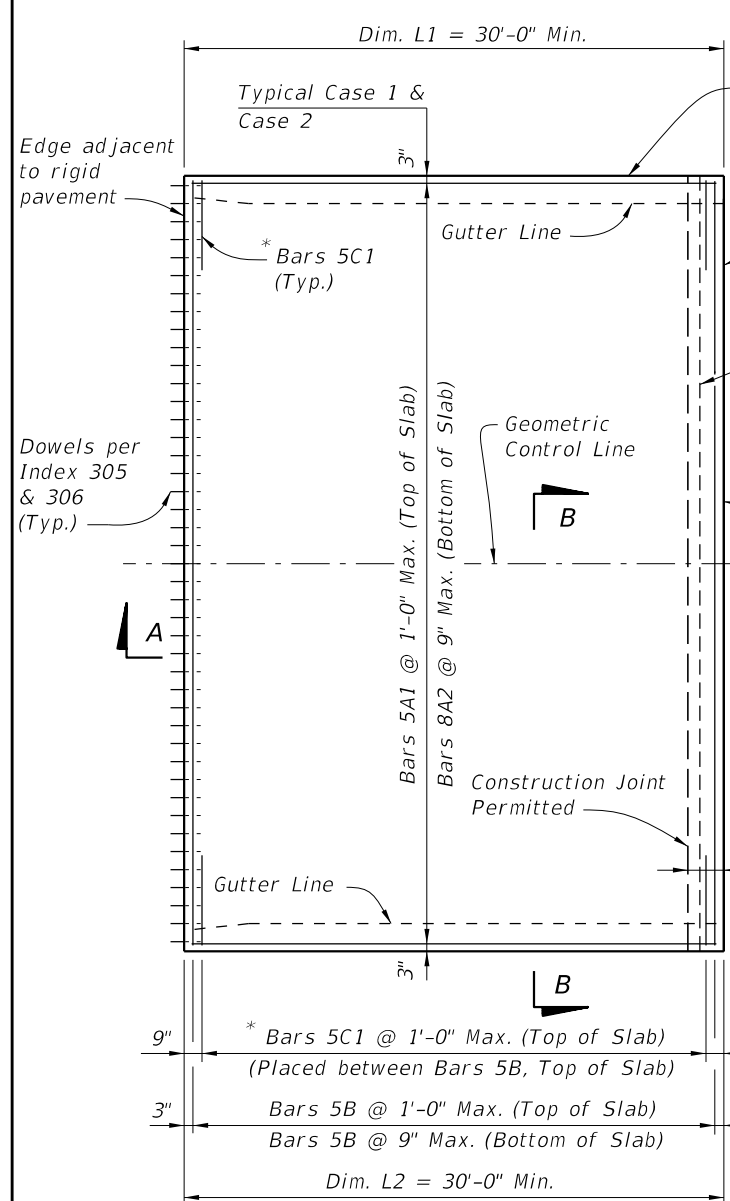

PLAN VIEW (CASE 1)

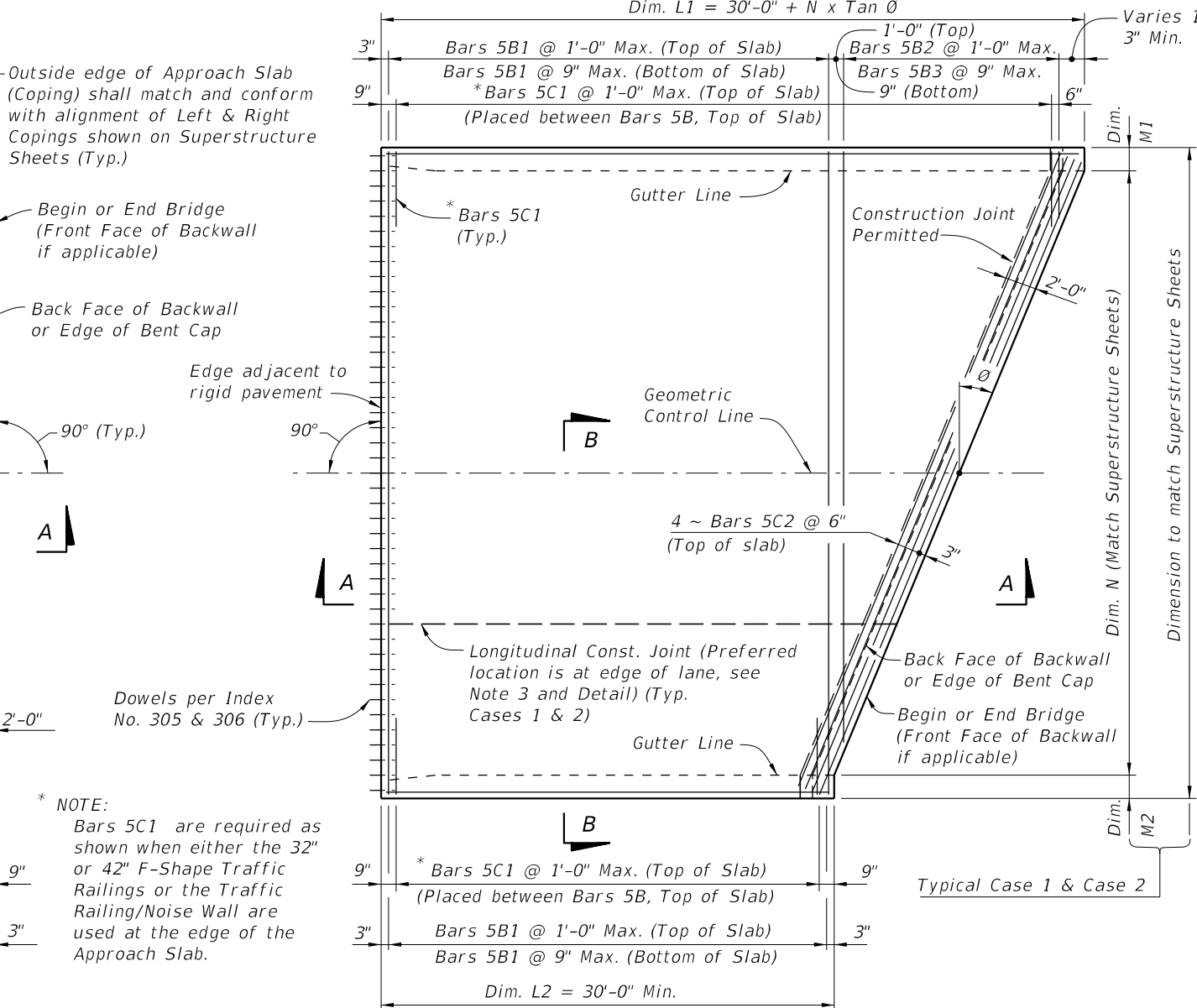

PLAN VIEW (CASE 2)

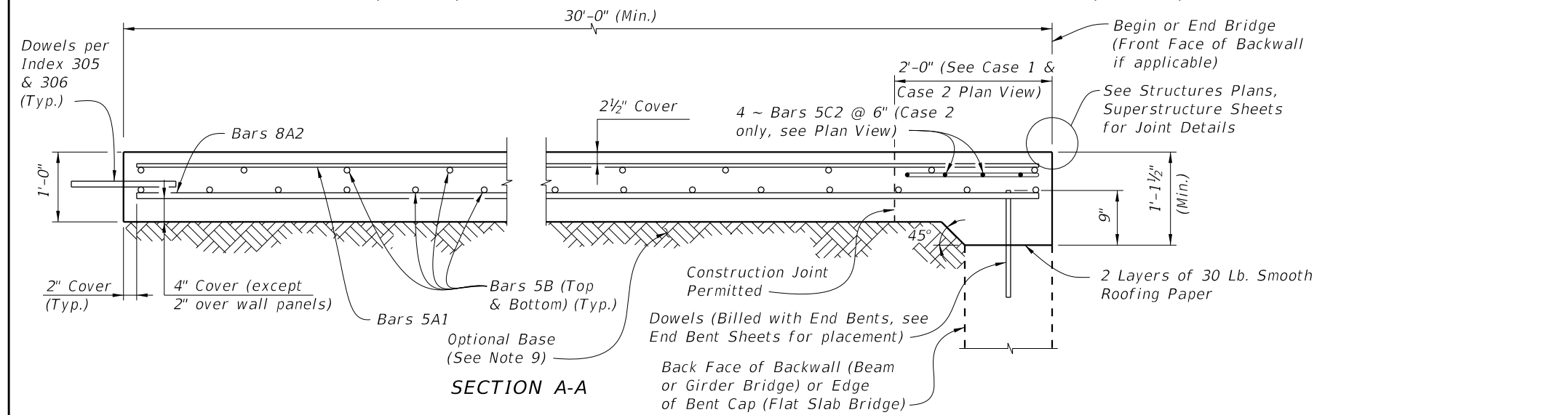

SECTION A-A

- GENERAL NOTES**
- SURFACE TREATMENT:** Apply a Class 4 Floor Finish (Grooved) to the riding surface from begin or end approach slab joint to begin or end bridge. See Bid Item Notes. Apply a broomed finish to sidewalk areas.
 - CONDUIT:** If required, see Structures Plans for Conduit details.
 - When a longitudinal construction joint is necessary or allowed by the Engineer, the transverse steel shall be extended as shown in the Longitudinal Construction Joint Detail.
 - The plan view for CASE 1 applies when the skew angle (θ) = 0°. Relevant details also apply to CASE 2.
 - The plan view for CASE 2 applies where the skew angle (θ) is > 0°. The slab shown represents a skew to the right for an approach slab at begin bridge; approach slab at the end of bridge or a left skew shall be treated similarly. The shown reinforcement shall be utilized, and Dowels shall be provided in accordance with Index Nos. 305 and 306.
 - Welded Wire Reinforcement (WWR) for the edge of Approach Slabs on retaining walls is not included in the estimated quantity for reinforcing steel and is considered incidental to the work. WWR must consist of Deformed wire meeting the requirements of Specification Section 931.
 - PROFILOGRAPH:** If profilograph requirements apply, planing may be required. The permitted construction joint shown in Section A-A will facilitate the placement of the expansion joint.
 - Approach slabs shown in Plan View Cases 1 and 2 represent a typical approach slab with edge barriers and no sidewalks. Provide railings, parapets, traffic separators and sidewalks as detailed on the additional approach slab sheets.
 - See Roadway Plans for Optional Base details and quantities.

CROSS REFERENCES:

For Section B-B, Longitudinal Construction Joint Detail and Approach Slab Details see Sheet 2.

12/17/2015 1:46:10 PM

LAST REVISION 07/01/15	REVISION	DESCRIPTION:	 FY 2016-17 DESIGN STANDARDS	APPROACH SLABS (RIGID PAVEMENT APPROACHES)	INDEX NO. 20910	SHEET NO. 1 of 2
---------------------------	----------	--------------	------------------------------------	---	--------------------	---------------------

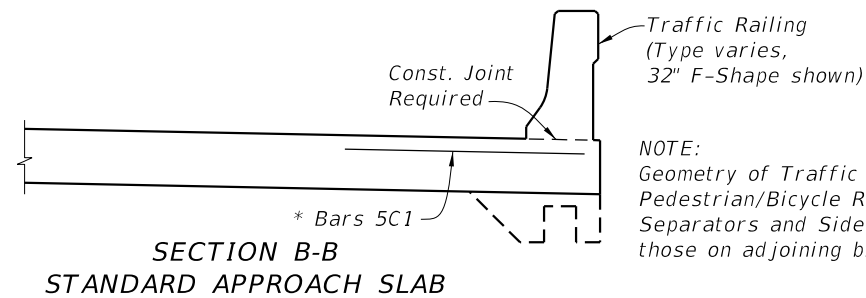

NOTE:
Geometry of Traffic Railings,
Pedestrian/Bicycle Railings, Traffic
Separators and Sidewalks to match
those on adjoining bridge.

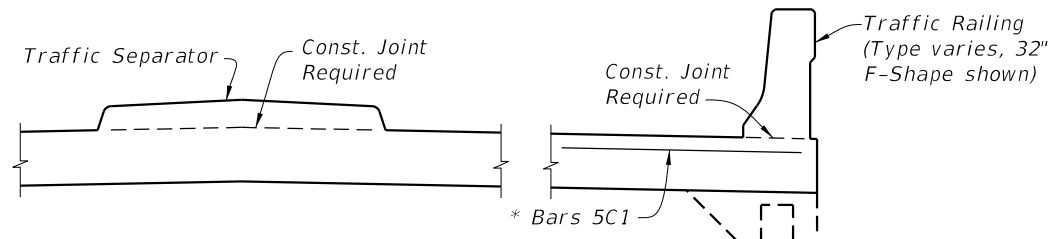

NOTE: Bars 5C are required as shown
when either the 32" or 42" F-Shape
Traffic Railing or the Traffic
Railing/Noise Wall are used at
the edge of the Approach Slab.

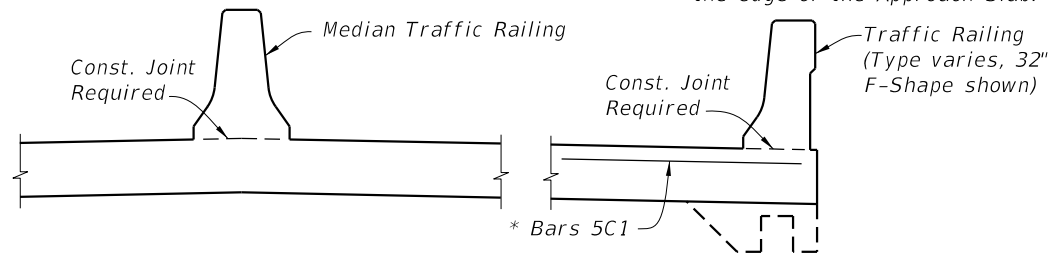

SECTION B-B
APPROACH SLAB WITH MEDIAN TRAFFIC RAILING

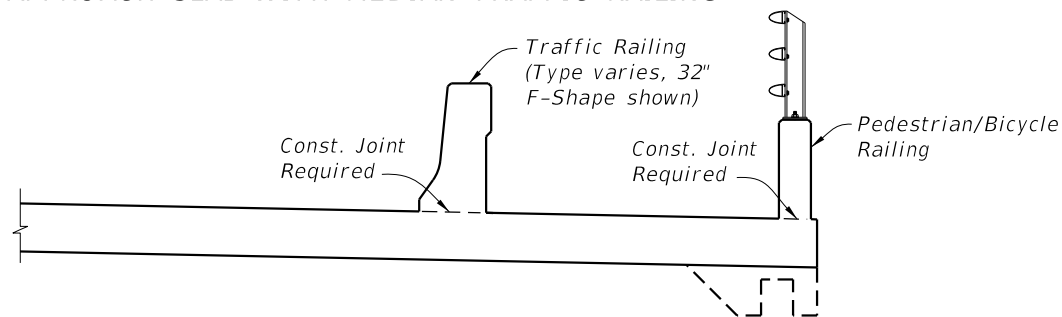

SECTION B-B
APPROACH SLAB WITH SIDEWALK

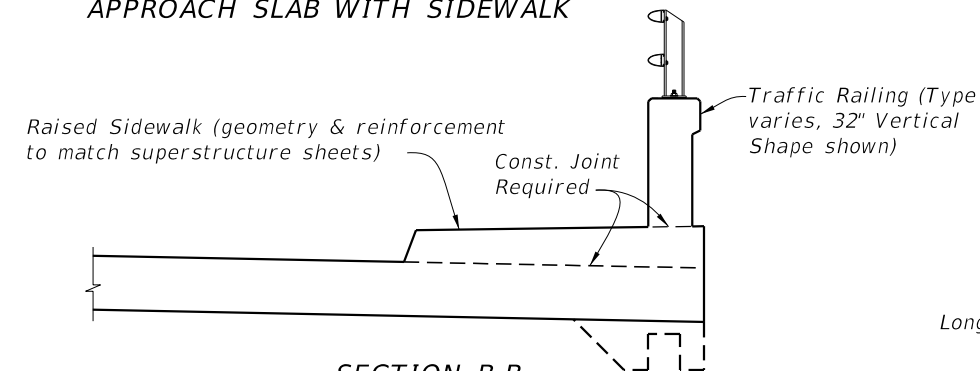

SECTION B-B
APPROACH SLAB WITH RAISED SIDEWALK

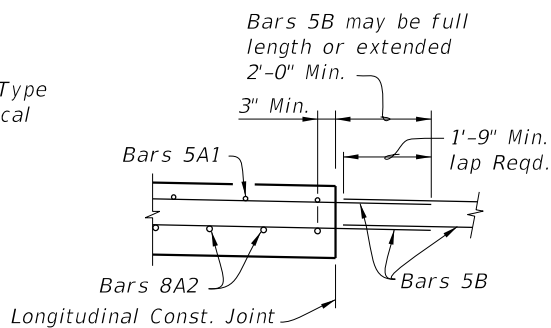

LONGITUDINAL CONSTRUCTION
JOINT DETAIL

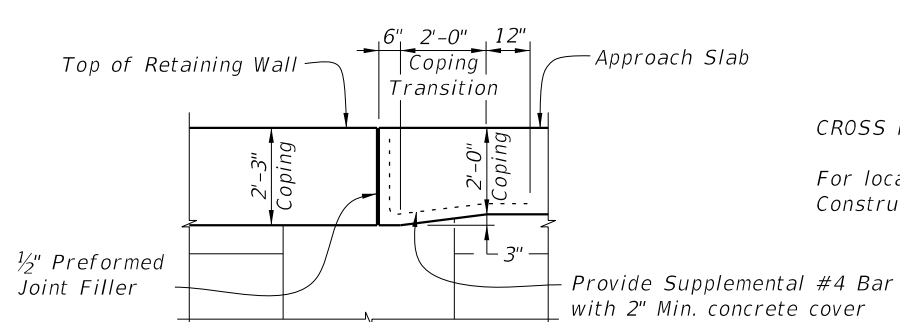

COPING TRANSITION DETAIL FOR
RETAINING WALLS WITH 2'-3" COPING HEIGHT
(Railing Not Shown For Clarity)

CROSS REFERENCES:

For location of Section B-B and Longitudinal
Construction Joint see Sheet 1.

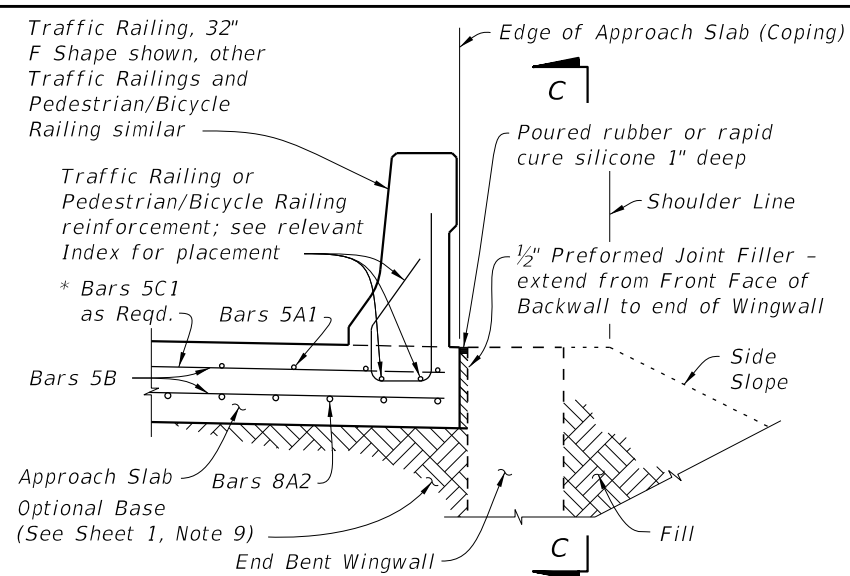

SECTION THRU APPROACH SLAB
AND END BENT WINGWALL

APPROACH SLAB WITH WINGWALL DETAILS

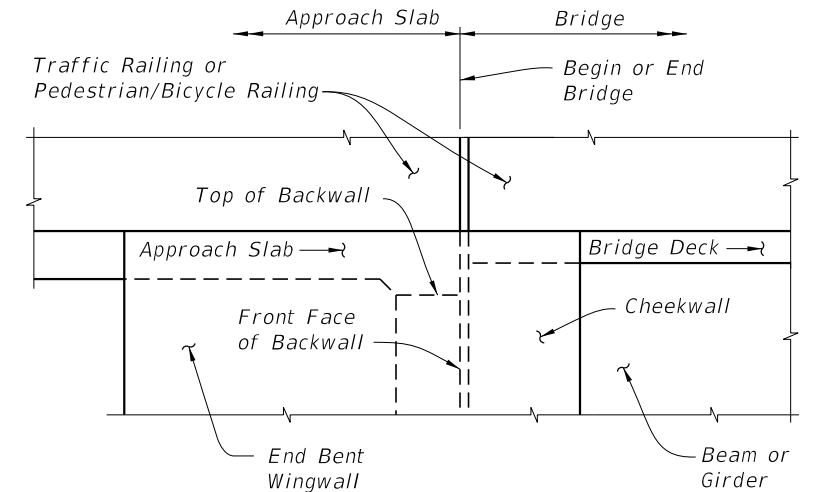

VIEW C-C AT BEGIN OR END BRIDGE (BEAM
BRIDGE SHOWN, FLAT SLAB BRIDGE SIMILAR)

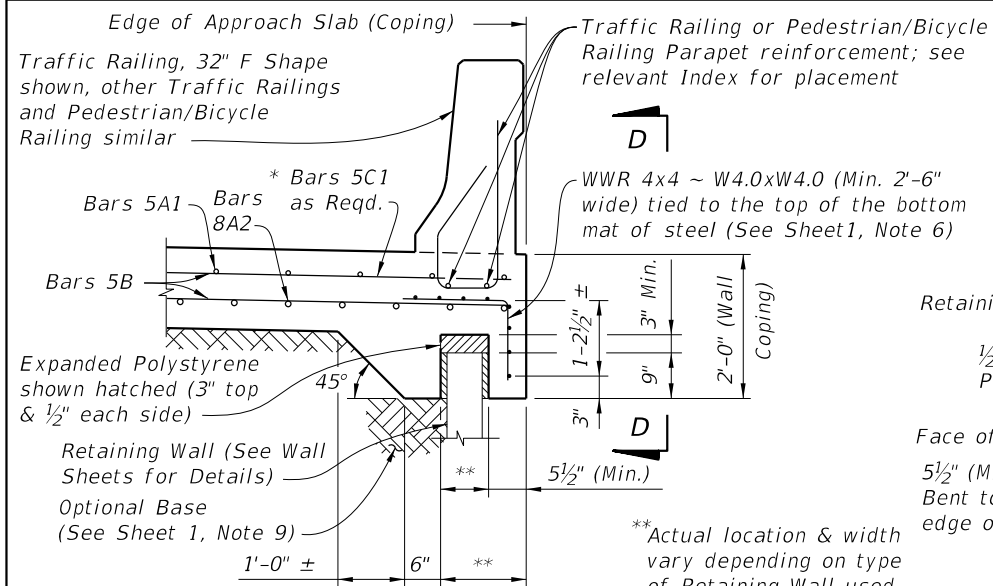

SECTION THRU APPROACH SLAB
AND RETAINING WALL

APPROACH SLAB WITH RETAINING WALL DETAILS

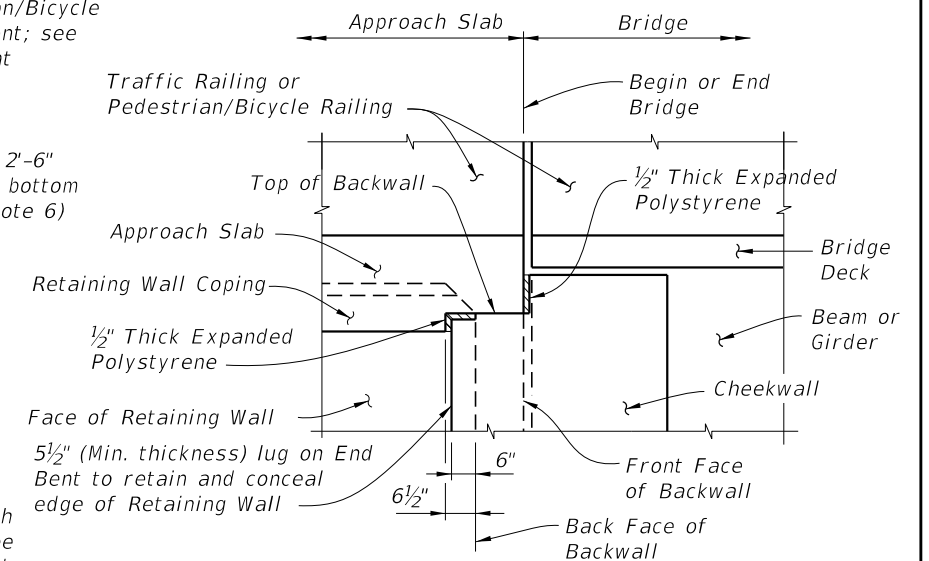

VIEW D-D AT BEGIN OR END BRIDGE (BEAM
BRIDGE SHOWN, FLAT SLAB BRIDGE SIMILAR)

12/17/2015 1:46:11 PM

LAST REVISION	DESCRIPTION:
07/01/14	



FY 2016-17
DESIGN STANDARDS

APPROACH SLABS
(RIGID PAVEMENT APPROACHES)

INDEX NO.
20910

SHEET NO.
2 of 2