

Aluminum Identification Tag Not To Exceed 2" x 4". Secure To Pole By 0.125" Stainless Steel Rivets Or Screws. Fabricators To Provide Details For Approval. Identification Tag Located On Inside Of Pole Visible From Handhole, Or On Outside Of Pole Inside Terminal Compartment. Tag To Be Stamped With The Following Information:

Standard Design	Special Design
Financial Project ID	Financial Project ID
Pole Type	Manufacturer's Name
Arm Type	Pole Base (F <sub>y</sub> of Steel)
Manufacturer's Name	Arm (F <sub>y</sub> of Steel)
Pole Base (F <sub>y</sub> of Steel)	Pole Wall Thickness (in.)
Arm (F <sub>y</sub> of Steel)	Arm Wall Thickness (in.)

**GENERAL NOTES**

- Signal Structure Materials shall be as follows:
  - Poles & Mast Arms & Backing Rings -> ASTM A1011 Grade 50, 55, 60 or 65 (less than 1/4") or ASTM A572 Grade 50, 55, 60 or 65 (1/4" and over) or ASTM A595 Grade A (55 ksi yield) or Grade B (60 ksi yield)
  - Steel Plates -> ASTM A36
  - Weld Metal -> E70XX
  - Bolts (except Anchor Bolts) -> ASTM A325 Type 1
  - Anchor Bolts -> ASTM F1554 Grade 55 ksi
  - Nuts for Anchor Bolts -> ASTM A563 Grade A Heavy Hex
  - Handhole Frame -> ASTM A709 Grade 36 ksi or ASTM A36
  - Handhole Cover -> ASTM A1011 Grade 50, 55, 60 or 65 ksi
  - Caps -> ASTM A1011 Grade 50, 55, 60 or 65 ksi or ASTM B209
  - Nut Covers -> ASTM B26 (319-F)
  - Stainless Steel Screws -> AISI Type 316
  - Threaded Bars/Studs -> ASTM A36 or ASTM A307
- Reinforcing Steel shall be ASTM A615 Grade 60 ksi.
- Concrete shall be Class IV (Drilled Shaft) with a minimum 28-day compressive strength of 4,000 psi for all environmental classifications.
- Perform all welding in accordance with the American Welding Society Structural Welding Code (Steel) ANSI/AWS D1.1 (current edition). For additional welding requirements see AASHTO Standard Specification for Structural Supports for Highway Signs, Luminaires and Traffic Signals, Section 5.15, Welded Connections.
- All steel items shall be galvanized as follows:
  - All Nuts, Bolts, Washers and Threaded Bars/Studs -> F2329
  - All other steel items (including Pole & Mast Arm) -> ASTM A123
- Locate handhole 180° from arm on single arm poles or 180° from first arm of double arm poles or see special instructions on Mast Arm Tabulation Sheet.
- Except for Anchor Bolts, all bolt hole diameters shall be equal to the bolt diameter plus 1/16", prior to galvanizing. Hole diameters for Anchor Bolts shall not exceed the bolt diameter plus 1/2".

- Sign Panels and Signals attached to the Mast Arm shall be centered in elevation on the arm. Wire access holes shall not exceed 1 1/2" in diameter.
- Mast Arms and Poles shall be tapered with the diameter changing at a rate of 0.14 inch per foot.
- The Pole shall be installed vertically. Camber shall be accounted for in the Mast Arm connection as detailed.
- If a Mast Arm damping device is required by the Engineer, it shall be installed within eight feet of the Mast Arm tip.
- Design according to FDOT Structures Manual. Alternate Designs for Special Mast Arm Assemblies are not allowed.
- Provide "J", or "C"-Hook at top of pole for signal cable support.
- First and Second Arm Camber Angle = 2°.
- Details for Signal and Sign Locations, Signal Head attachment, Sign Attachment, Pedestrian Head Attachment, and Foundation Conduit are not shown for clarity.
- Use of split lock washer is not permitted.
- This Design Standard is considered fully detailed and no shop drawings are necessary. Submit shop drawings for minor modifications not detailed in the plans.
- Verify CSL access tubes will not interfere with anchor bolt installation before excavating the shaft. When CSL access tube locations conflict with anchor bolt locations, move the CSL access tube location +/- two inches along the inner circumference of the reinforcing cage. Notify the Engineer before excavating the shaft if the CSL access tube locations cannot be moved out of conflict with anchor bolt locations.

**ELEVATION VIEW**  
(Single Arm Shown, Double Arm Similar)  
(Luminaire Arm Not Shown)

\*\* NOTE: Contractor shall verify this Dimension prior to fabrication of Pole.

**TYPICAL ELEVATION AND NOTES**

6/30/2014 11:14:48 AM

LAST REVISION 07/01/14	REVISION	DESCRIPTION:	 2015 DESIGN STANDARDS	<b>MAST ARM ASSEMBLIES</b>	INDEX NO. 17745	SHEET NO. 1 of 5
---------------------------	----------	--------------	------------------------------	----------------------------	--------------------	---------------------

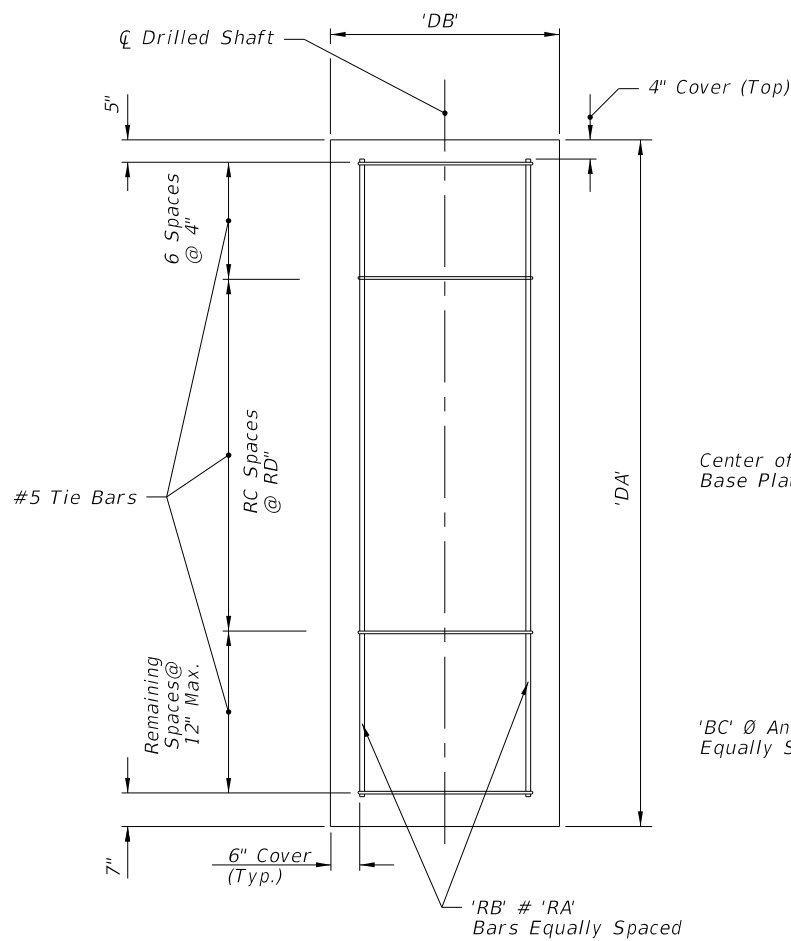

SECTION A-A

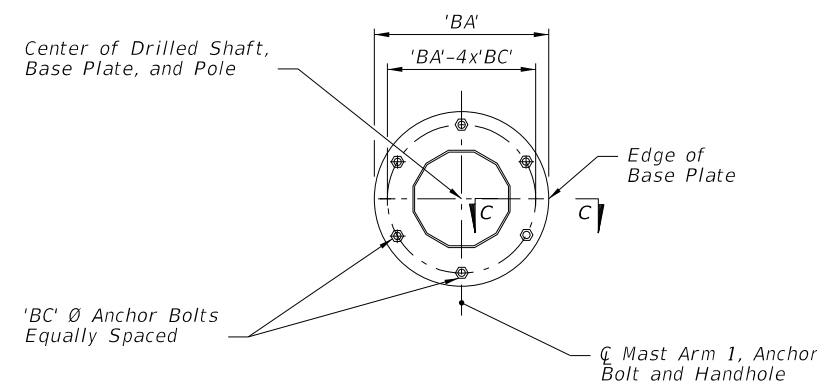

SECTION B-B  
(6 Anchor Bolts)

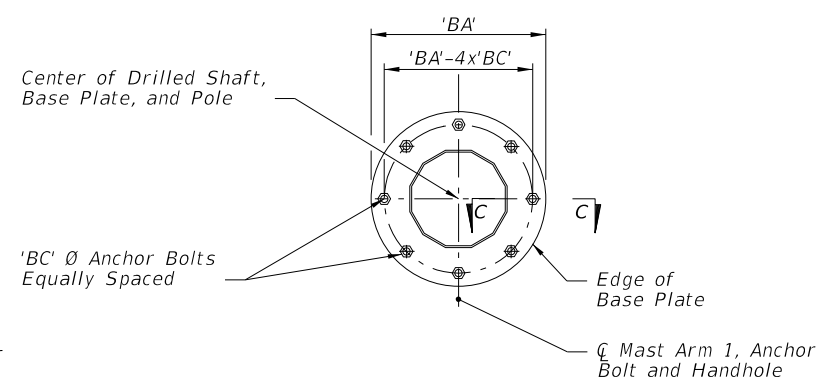

SECTION B-B  
Alternate Detail  
(8 Anchor Bolts)

NOTE:  
See Index No. 17743 and the plans for actual quantity of bolts.

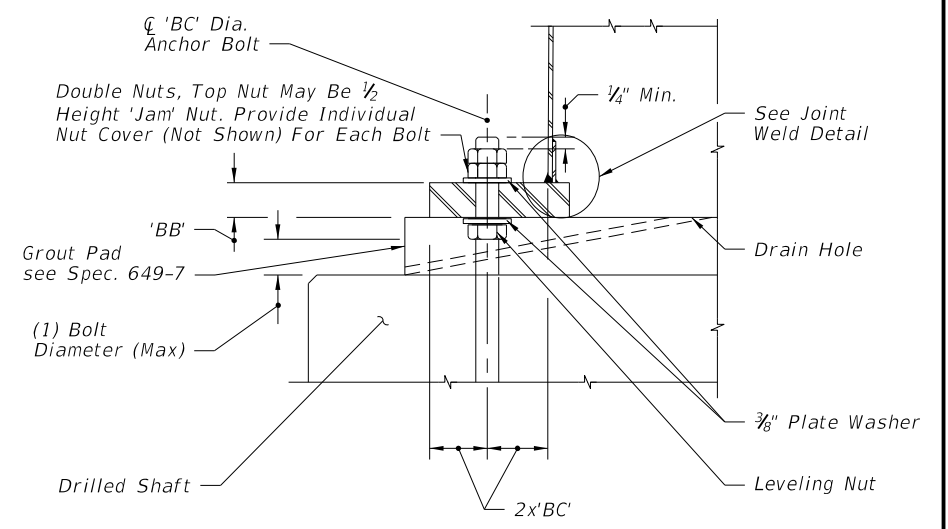

SECTION C-C

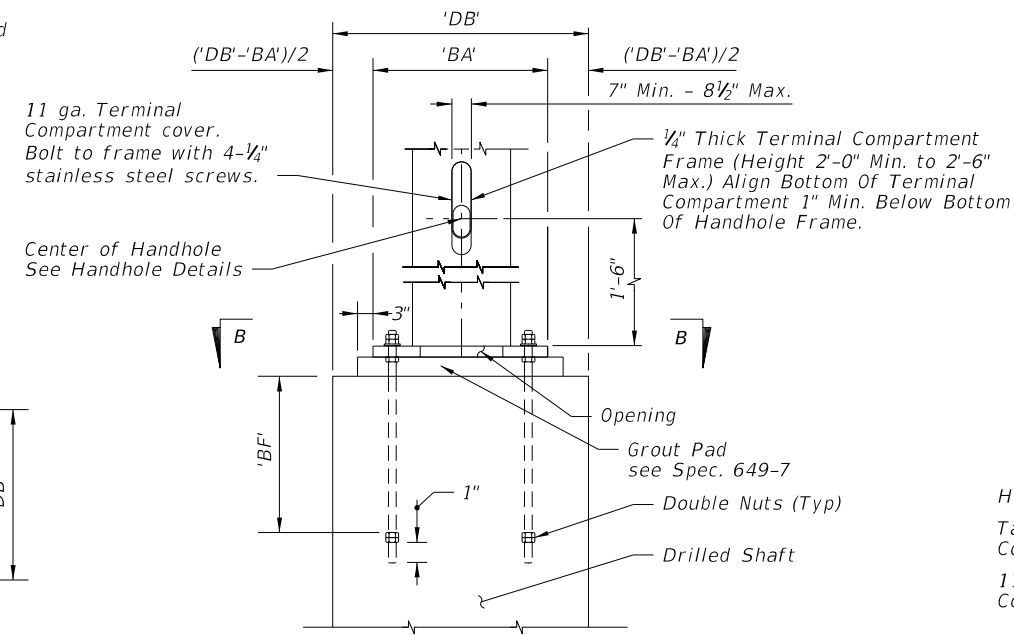

BASE PLATE AND ANCHORAGE ELEVATION  
(Reinforcement Not Shown)

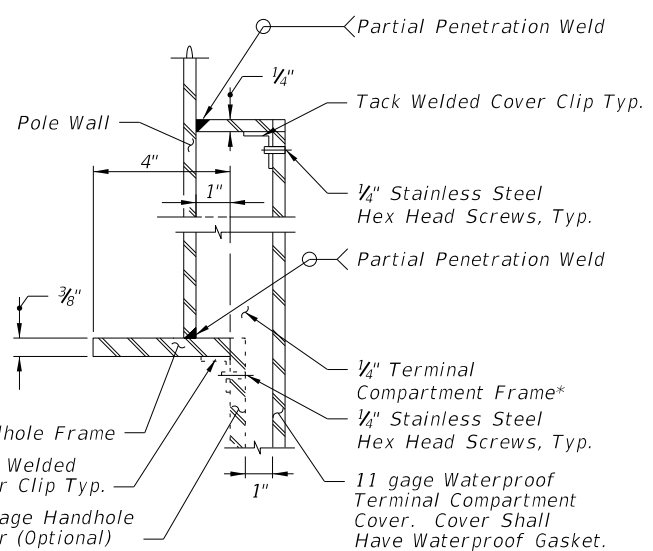

SECTION D-D  
(Thru Handhole & Terminal Compartment)

\* Terminal Compartment is optional. See Mast Arm Tabulation to see if required and for locations.

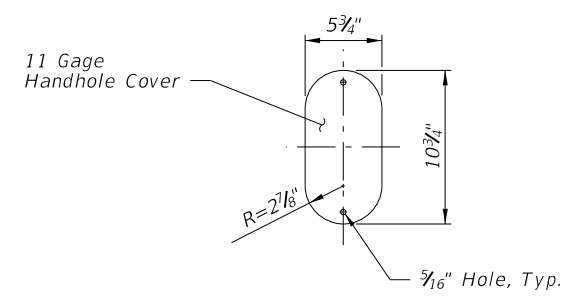

HANDHOLE COVER

Note:  
Handhole Cover may be omitted when Terminal Compartment is provided.

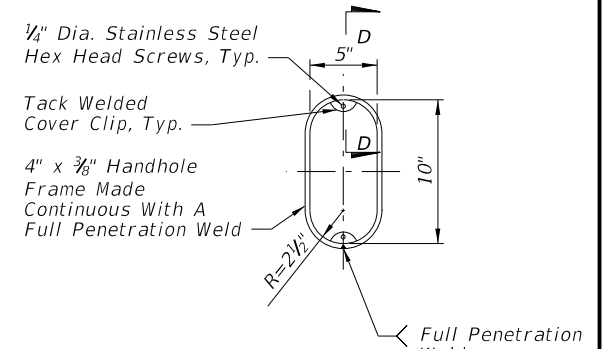

HANDHOLE FRAME  
(w/Terminal Compartment Omitted)

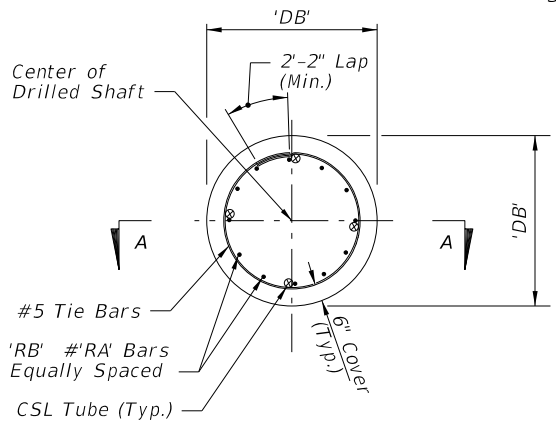

FOUNDATION PLAN

TYPICAL FOUNDATION AND BASE PLATE DETAILS

6/30/2014 11:14:49 AM

LAST REVISION 07/01/14	REVISION	DESCRIPTION:	 2015 DESIGN STANDARDS	MAST ARM ASSEMBLIES	INDEX NO. 17745	SHEET NO. 2 of 5
---------------------------	----------	--------------	------------------------------	---------------------	--------------------	---------------------

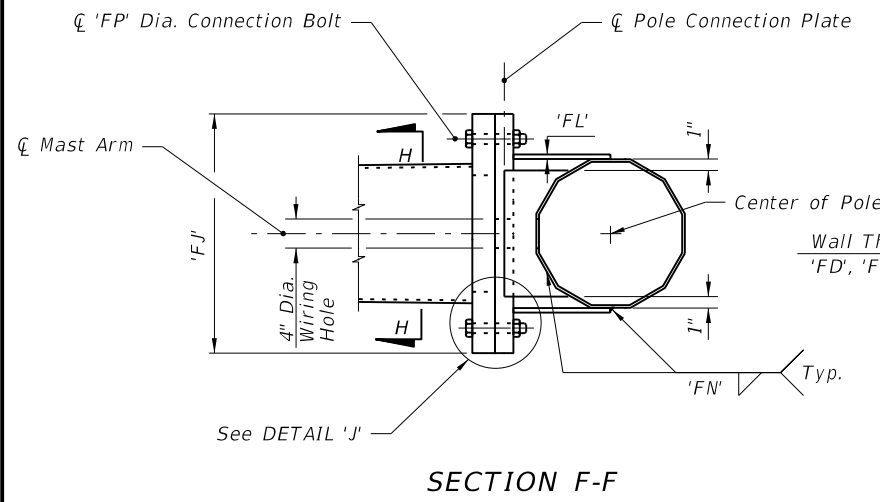

SECTION F-F

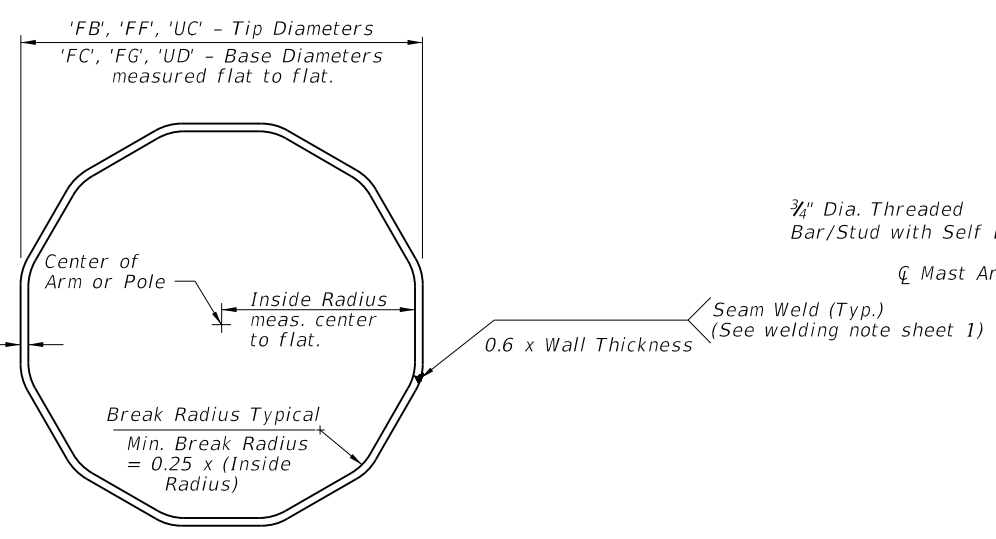

SECTION H-H

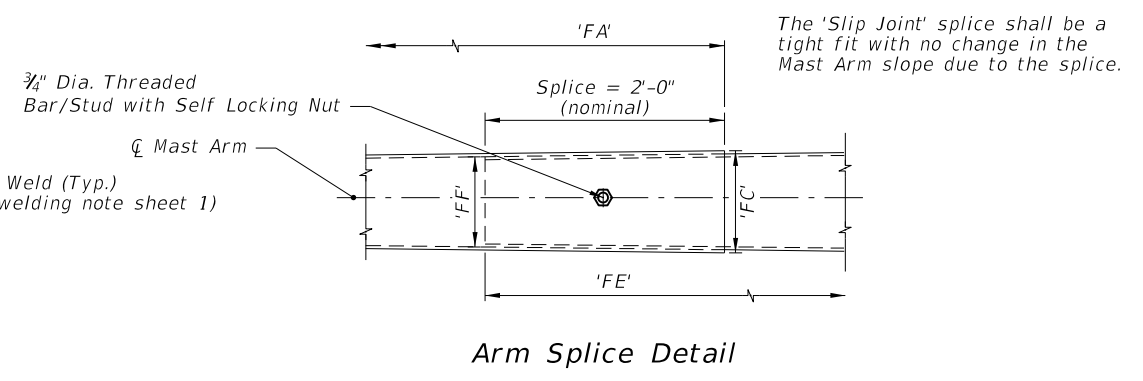

Arm Splice Detail

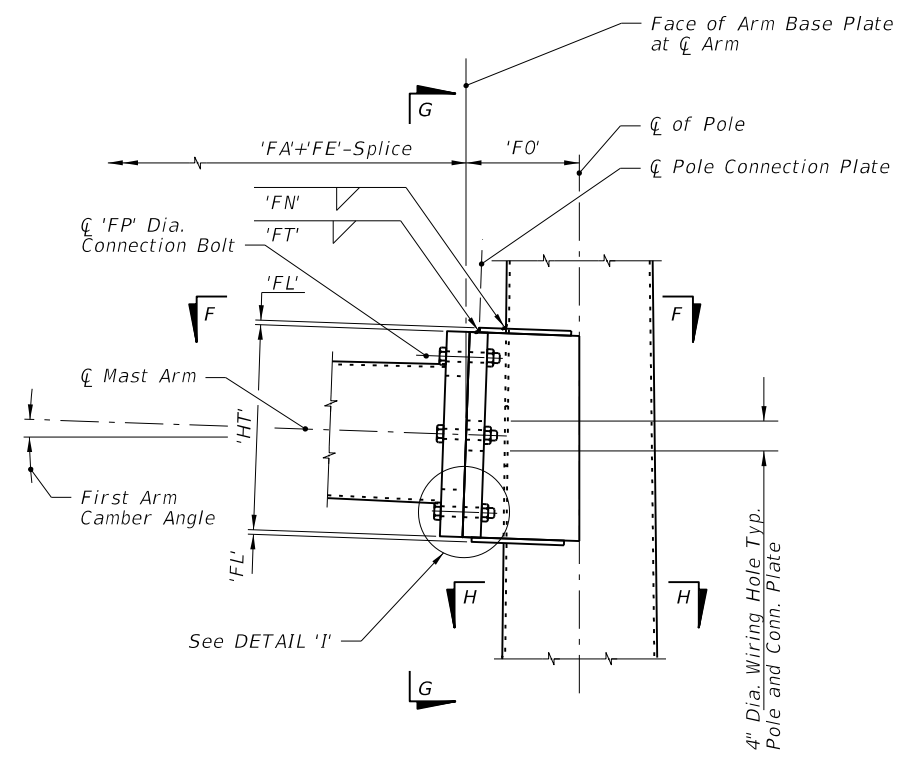

ELEVATION  
(Single Arm Connection)

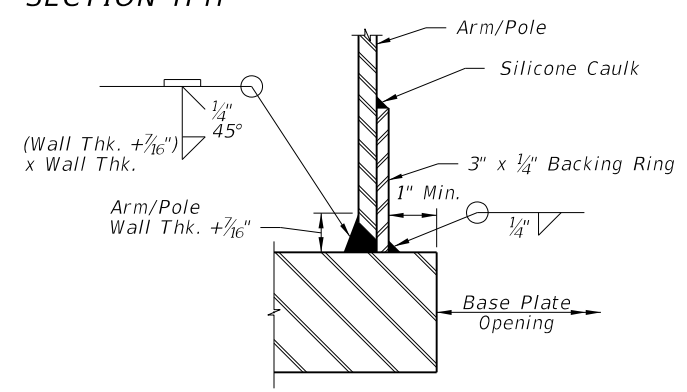

JOINT WELD DETAIL

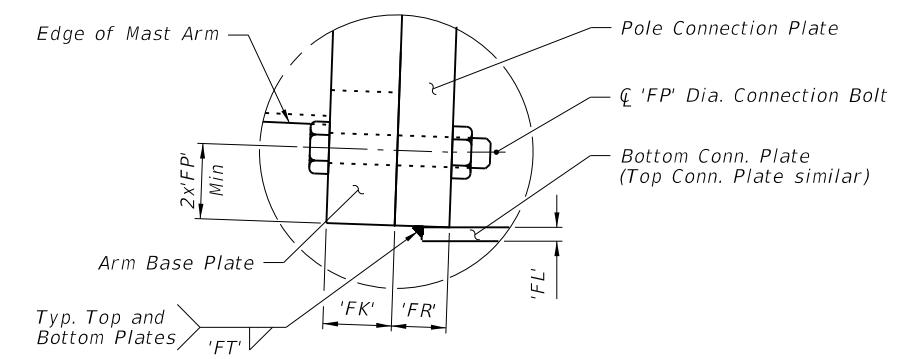

DETAIL 'I'

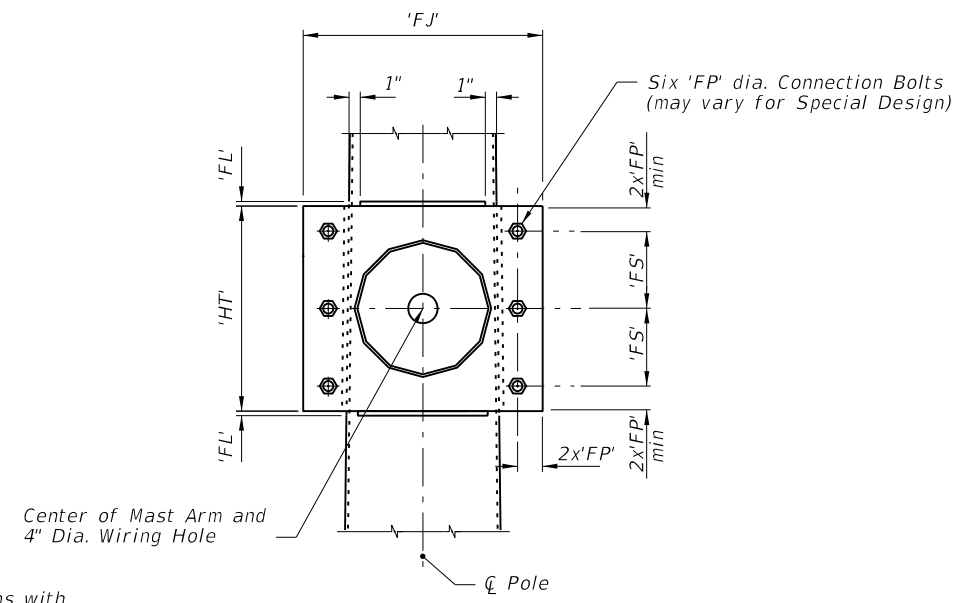

SECTION G-G

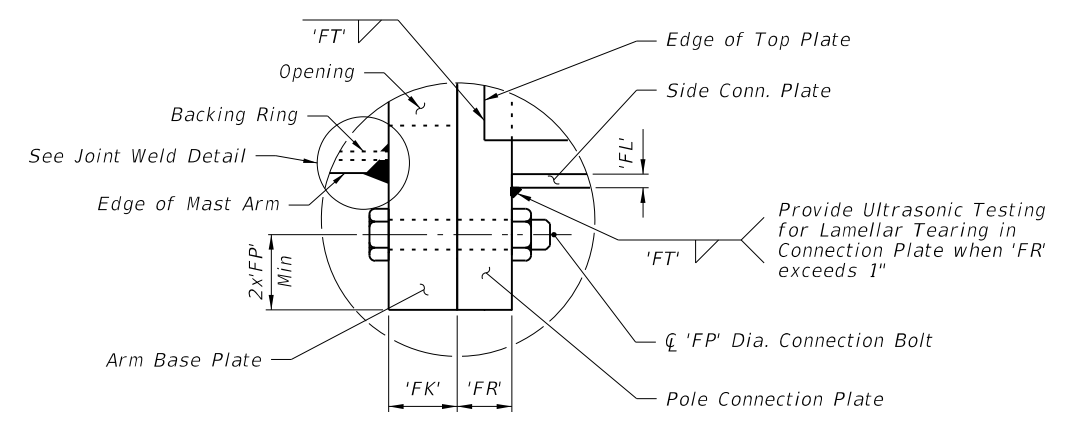

DETAIL 'J'

TYPICAL SINGLE ARM CONNECTION DETAILS

- NOTE:
1. Details shown on this sheet are for 12 sided pole sections. However, sections with more than 12 sides and round sections are permitted provided outside diameter and wall thickness are not reduced.
  2. Mast Arm and Connection Plates shall be match marked to ensure proper assembly.

6/30/2014 11:14:50 AM

LAST REVISION	REVISION	DESCRIPTION:	 2015 DESIGN STANDARDS	MAST ARM ASSEMBLIES	INDEX NO. 17745	SHEET NO. 3 of 5
07/01/13						

6/30/2014 11:14:51 AM

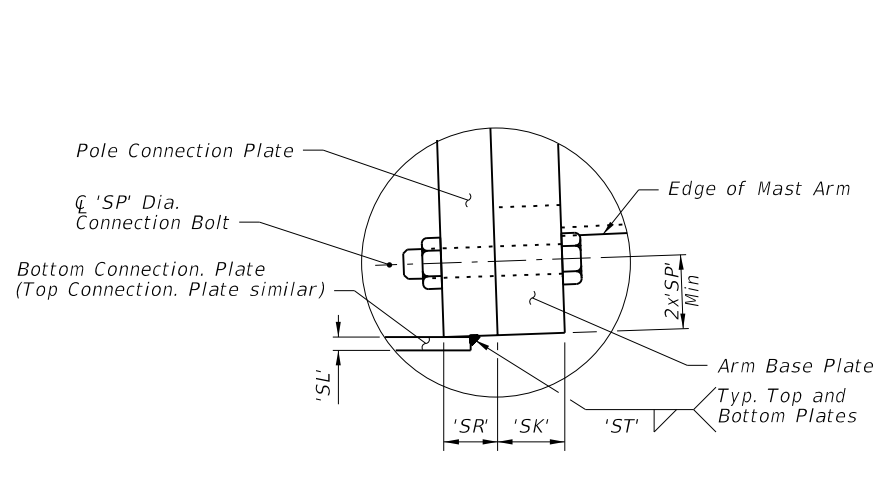

DETAIL 'N'

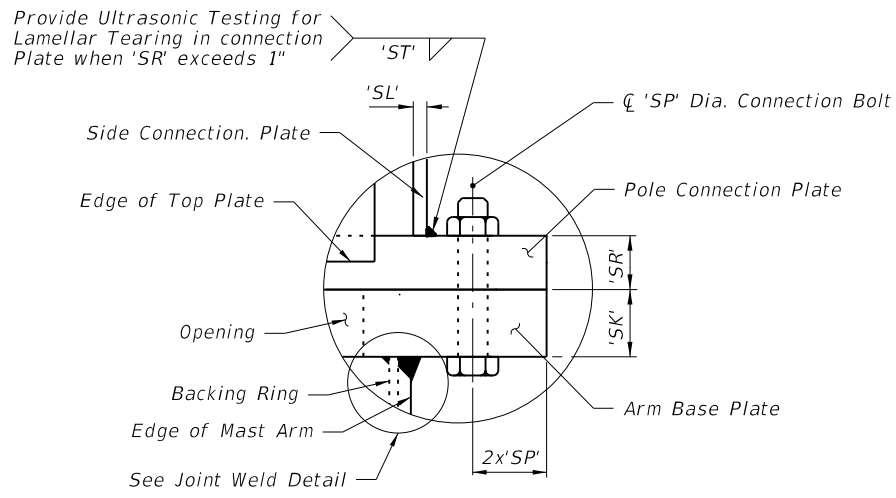

DETAIL 'O'

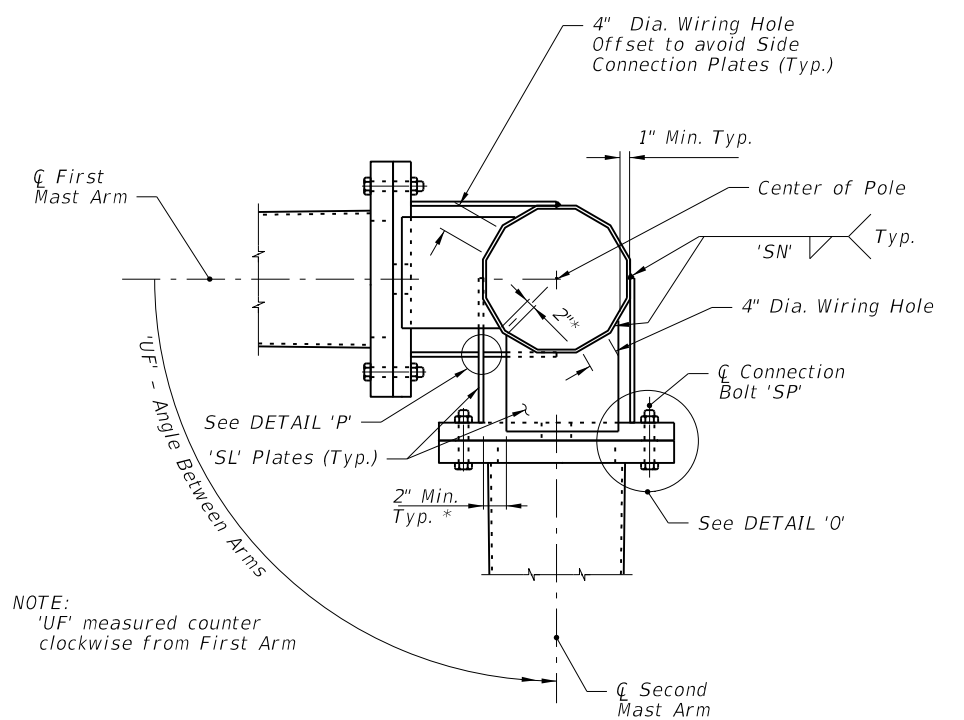

SECTION K-K

\* Adjust width of top and bottom Connection Plates to maintain minimum clearance shown

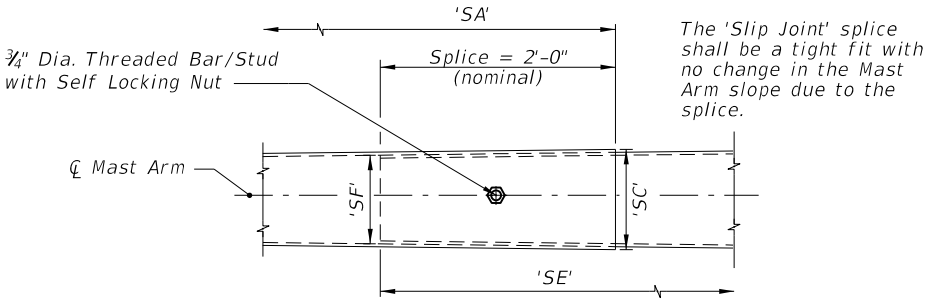

Arm Splice Detail

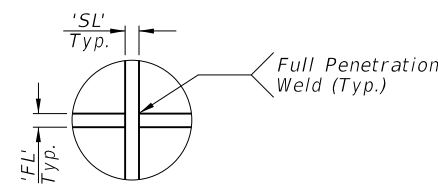

DETAIL 'P'

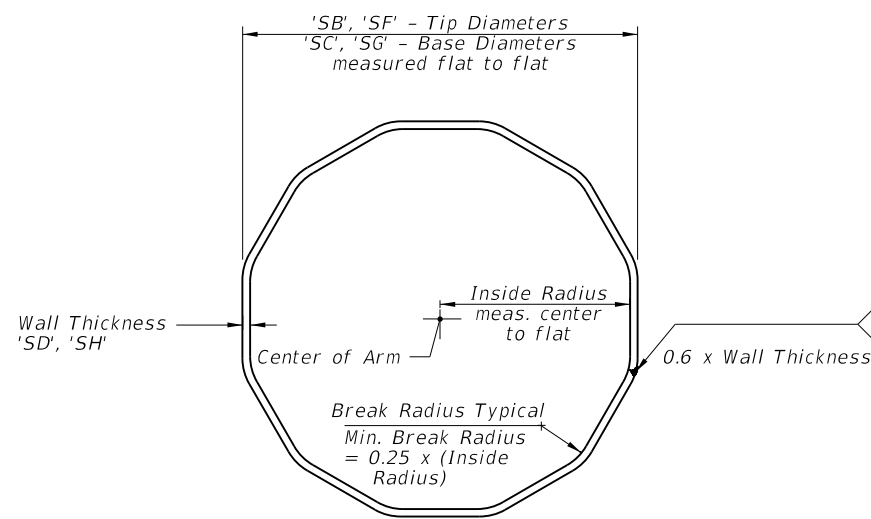

SECTION M-M

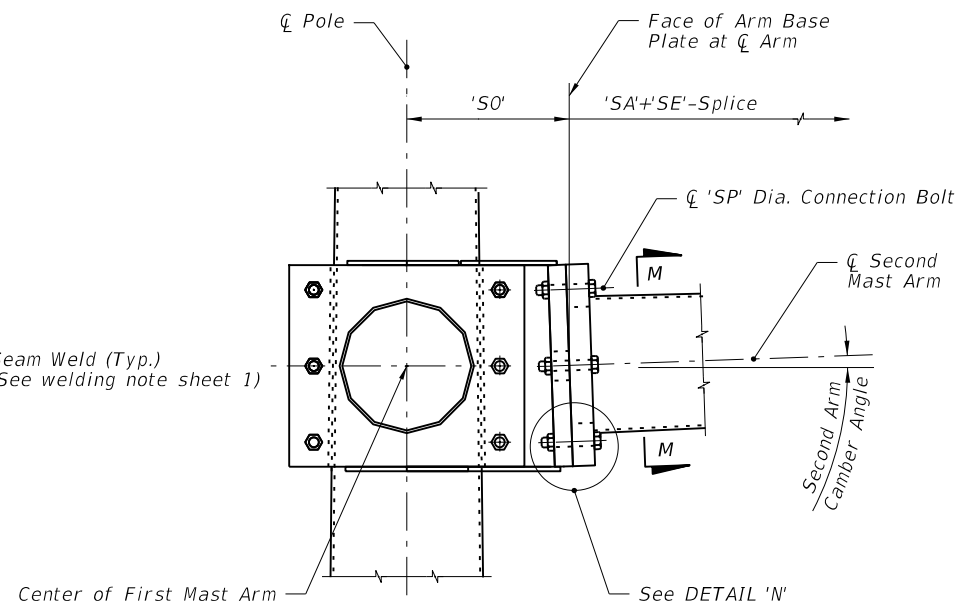

SECTION L-L

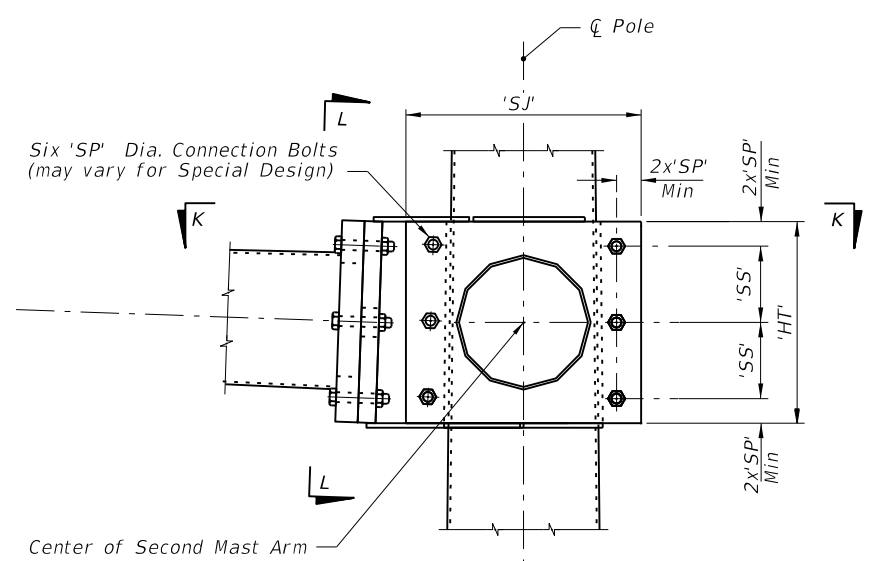

ELEVATION

(Double Arm Connection)

NOTE:  
 1. Details shown on this sheet are for 12 sided pole sections. However, sections with more than 12 sides and round sections are permitted provided outside diameter and wall thickness are not reduced.  
 2. Mast Arm and Connection Plates shall be match marked to ensure proper assembly.

TYPICAL DOUBLE ARM CONNECTION DETAILS

LAST REVISION 01/01/12	DESCRIPTION:	FDOT 2015 DESIGN STANDARDS	MAST ARM ASSEMBLIES	INDEX NO. 17745	SHEET NO. 4 of 5
---------------------------	--------------	----------------------------	---------------------	--------------------	---------------------

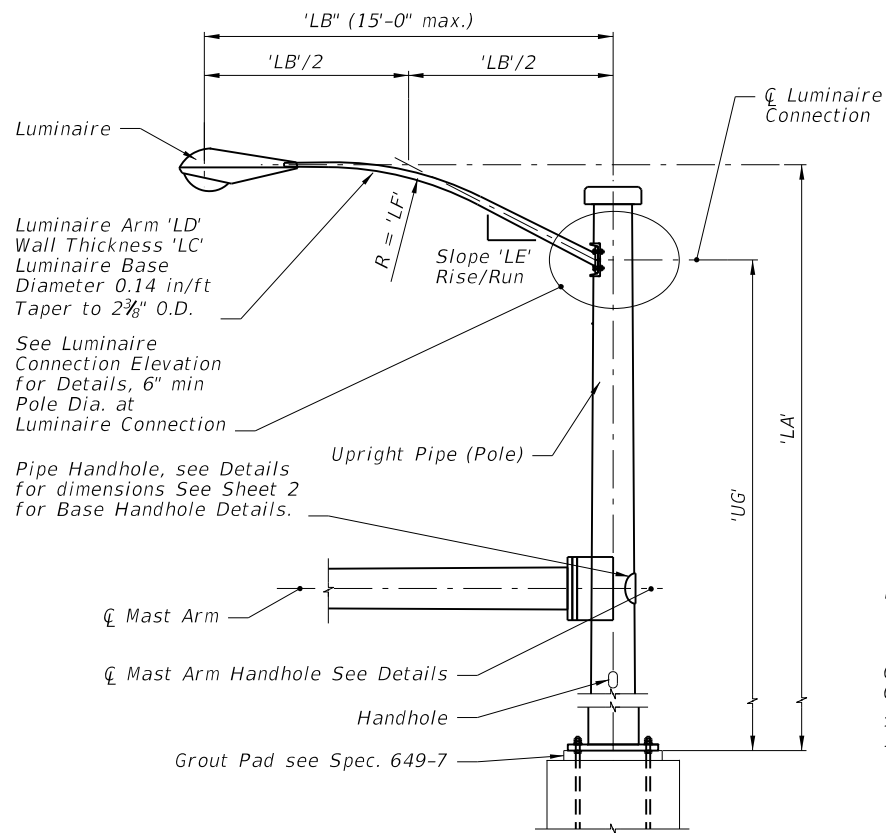

LUMINAIRE ELEVATION

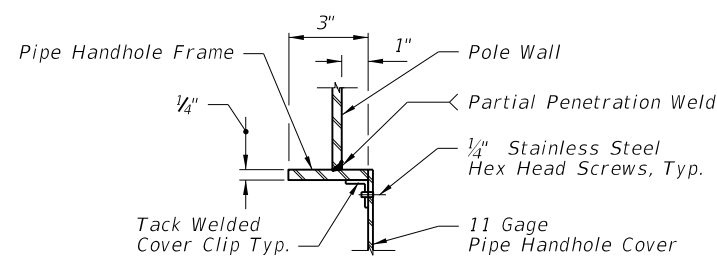

SECTION E-E  
(thru Pipe Handhole)

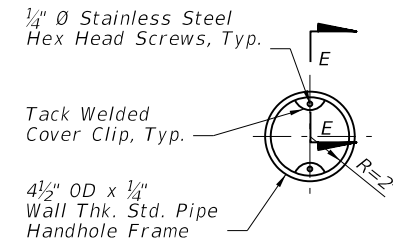

PIPE HANDHOLE FRAME

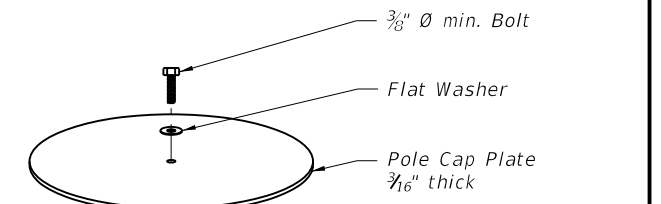

TOP VIEW

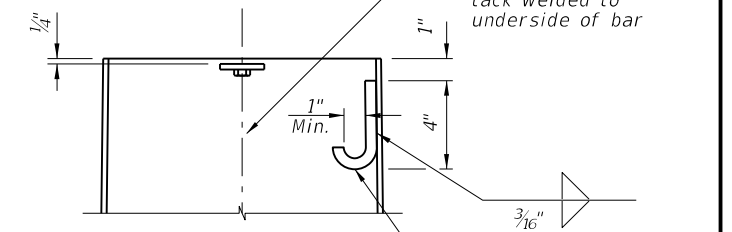

POLE TOP CUT-AWAY  
(Option 'a')

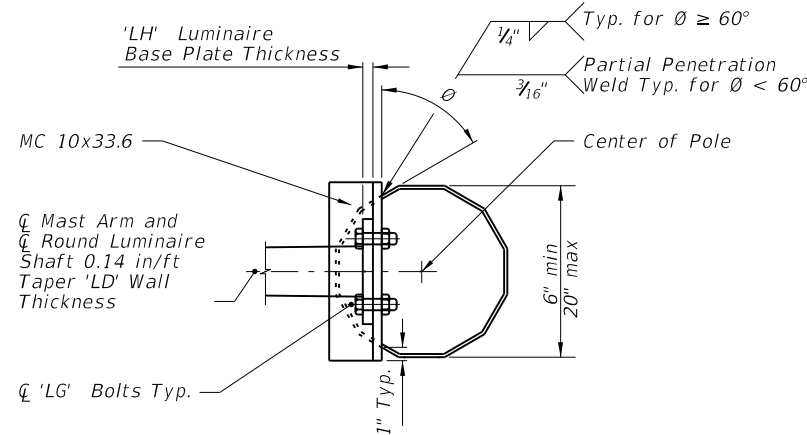
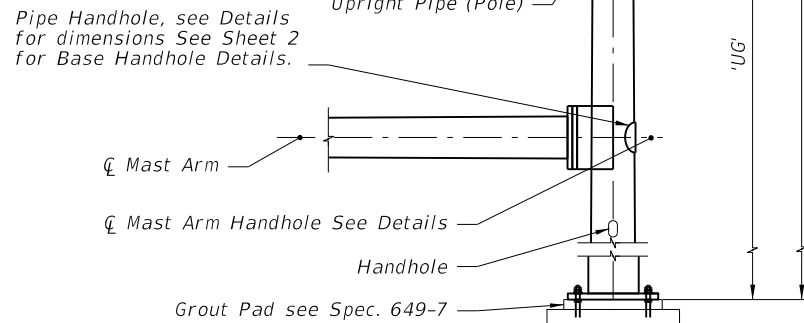

SECTION A-A

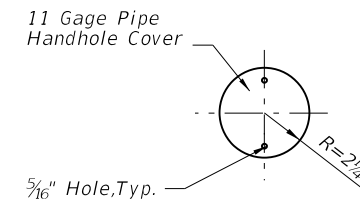

PIPE HANDHOLE COVER

'J' Hook for wiring, 1/2" Ø commercial grade hot rolled bar welded to inside of pole.

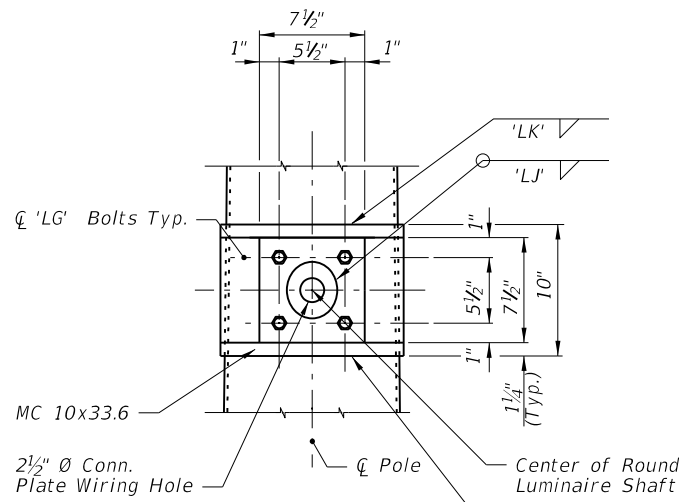

SECTION B-B

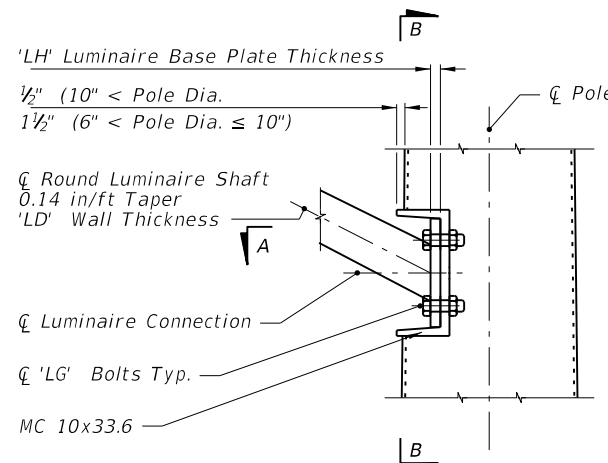

LUMINAIRE CONNECTION ELEVATION

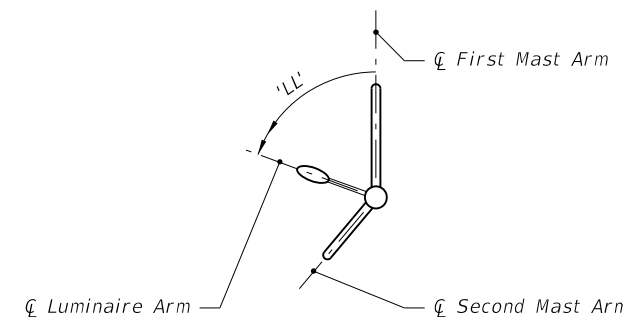

LUMINAIRE ORIENTATION

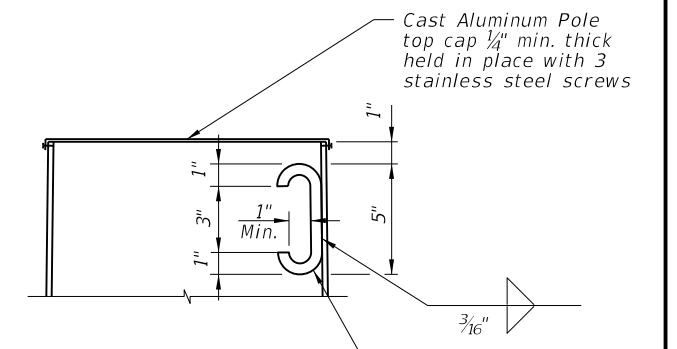

POLE TOP CUT-AWAY  
(Option 'b')

POLE TOP DETAILS

NOTE:  
The Fabricator may substitute a 1/2" thick bent plate with the same flange width, height, and length as the MC 10x33.6 Channel section.

NOTE:  
The Pole shown on this sheet is a 12 sided section. However, sections with more than 12 sides and round sections are permitted provided outside diameter and wall thickness are not reduced

NOTE:  
'LL' measured counter clockwise from First Arm.

NOTE:  
Any combination of the above two options may be used, provided both lifting and wiring is accommodated.

NOTES:

1. Luminaire type and Luminaire to Arm Connection Details can be found elsewhere.
2. Align Luminaire Arm with single Mast Arm or first Arm of Double Mast Arm unless indicated otherwise in plans.

TYPICAL LUMINAIRE ARM AND CONNECTION DETAILS

6/30/2014 11:14:51 AM

LAST REVISION 07/01/14	DESCRIPTION:		2015 DESIGN STANDARDS	MAST ARM ASSEMBLIES	INDEX NO. 17745	SHEET NO. 5 of 5
REVISION						