

PLAN VIEW OF ACCESS HATCH ASSEMBLY

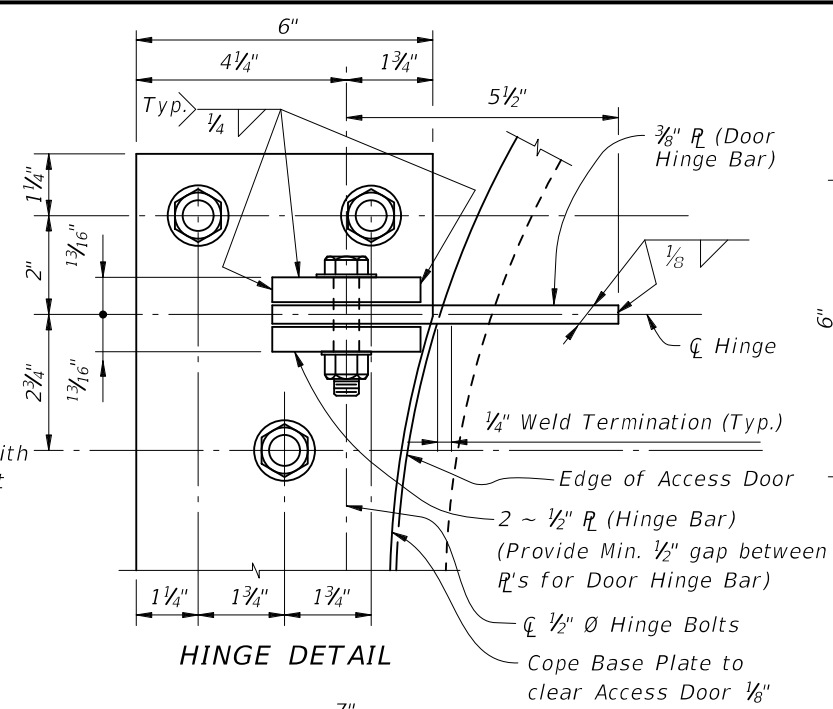

HINGE DETAIL

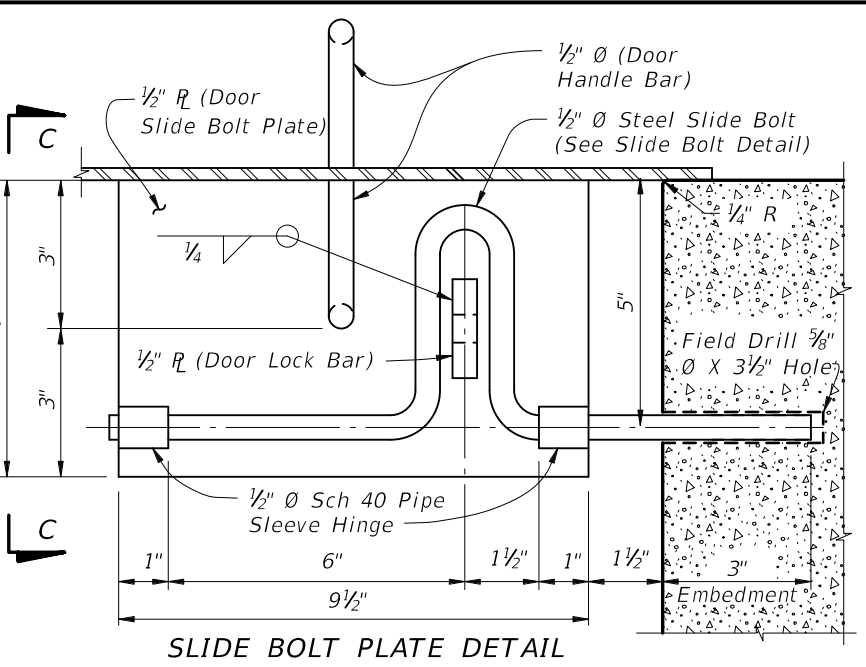

SLIDE BOLT PLATE DETAIL

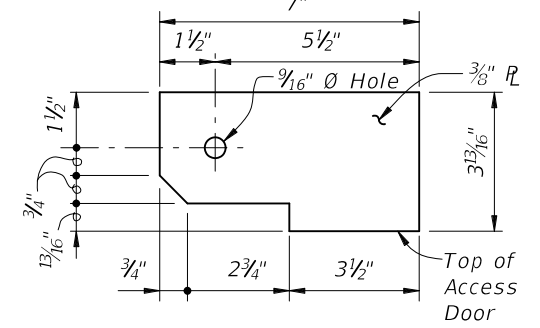

DOOR HINGE BAR DETAIL

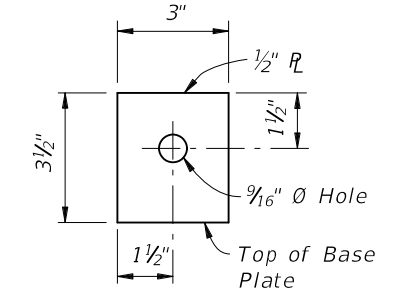

HINGE BAR DETAIL

HINGE NOTE:
1. Orient the Access Door so that the hinges are located down-grade.

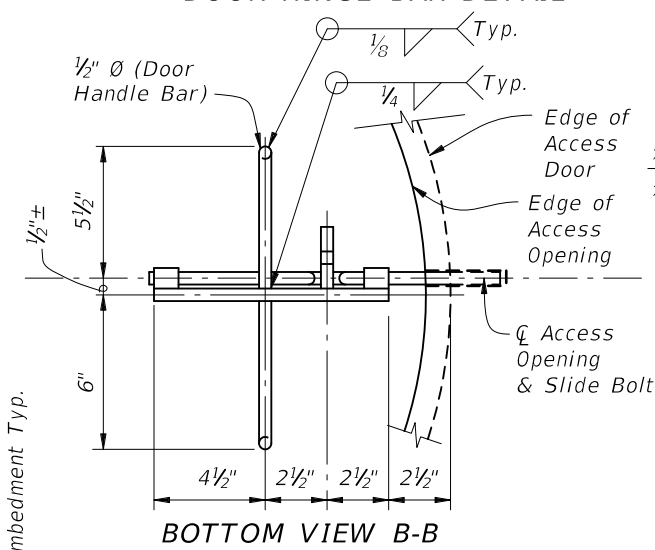

BOTTOM VIEW B-B

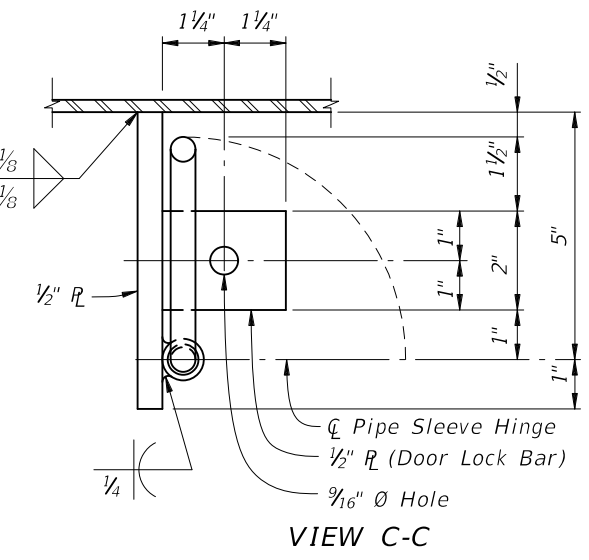

VIEW C-C

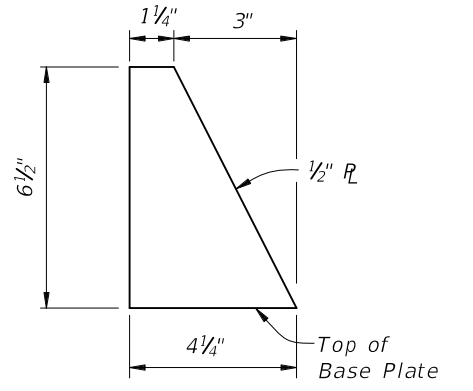

STOP BAR DETAIL

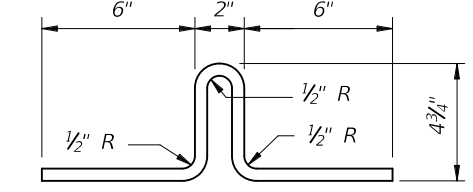

SLIDE BOLT DETAIL

- NOTES:
1. All Structural Steel material in Access Door Assemblies shall conform to ASTM A709 Grade 36.
 2. 1 1/2" Ø Pipe Grab Rail shall be in accordance with ASTM A53 Grade B for standard weight pipe (Schedule 40).
 3. 1/2" Ø Door Handle Bar shall be in accordance with ASTM A36.
 4. All bolts shall conform to ASTM A307 or A449. All nuts shall conform to ASTM A563 and all washers shall conform to ASTM F-436.
 5. All exposed edges of plates and openings shall be ground smooth.
 6. See Framing Plan sheets for locations of Access Door Openings.
 7. Coat structural steel in accordance with Section 560 of the Standard Specifications.
 8. All costs associated with Access Hatch Assembly and incidental items will be paid for under the Access Hatch Assembly pay item. No separate payment will be made for coating structural steel.

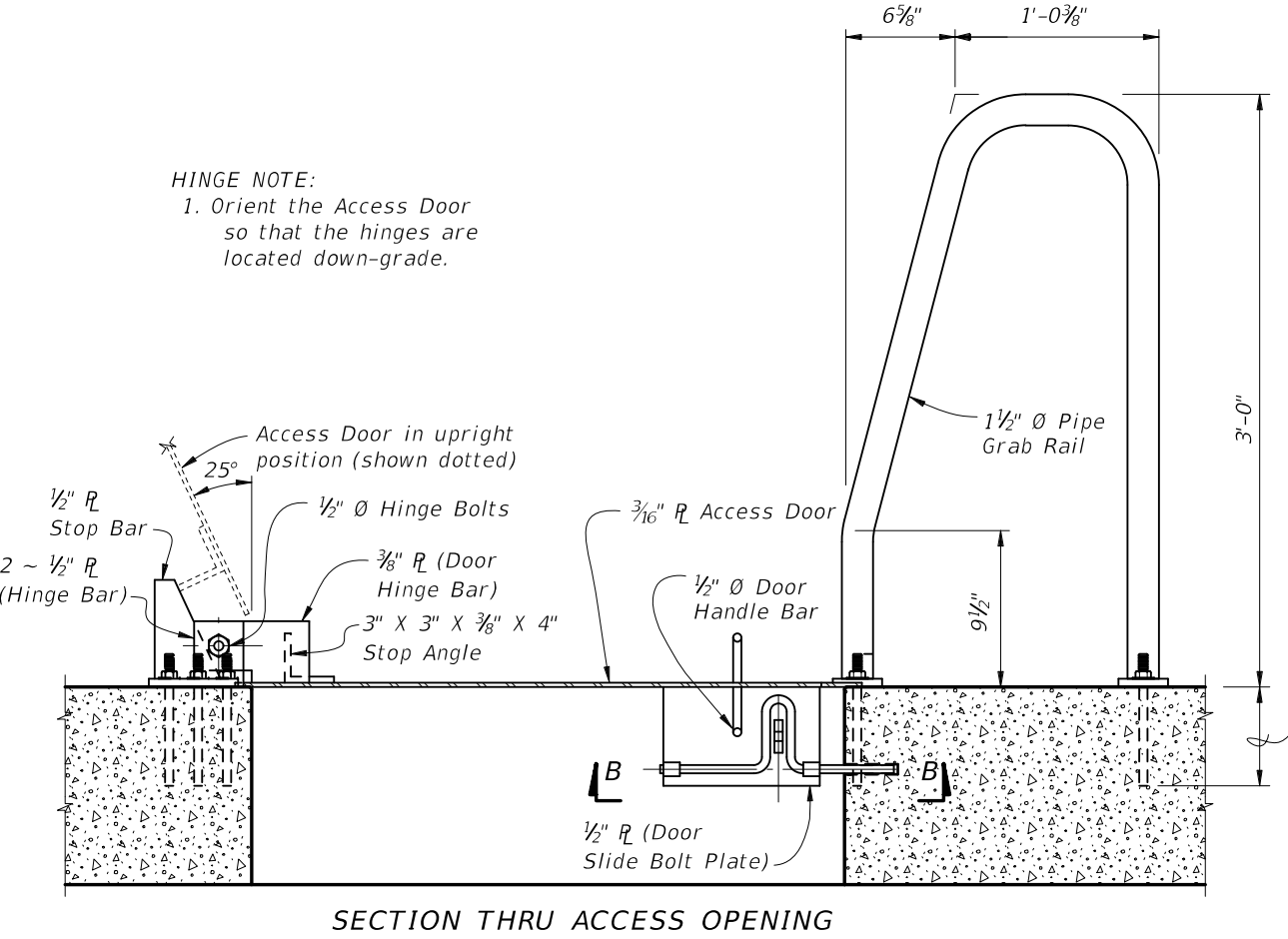

SECTION THRU ACCESS OPENING

REVISIONS

DATE	BY	DESCRIPTION	DATE	BY	DESCRIPTION
01/01/11	GJM	New Design Standard			

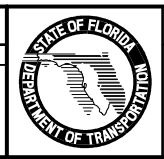

2010 Interim Design Standard

ACCESS HATCH ASSEMBLY
FOR CONCRETE BOX SECTIONS

Interim Date	Sheet No.
01/01/11	1 of 1
Index No.	
21251	