

See legend for number of luminaires, lamp wattage and light distribution.

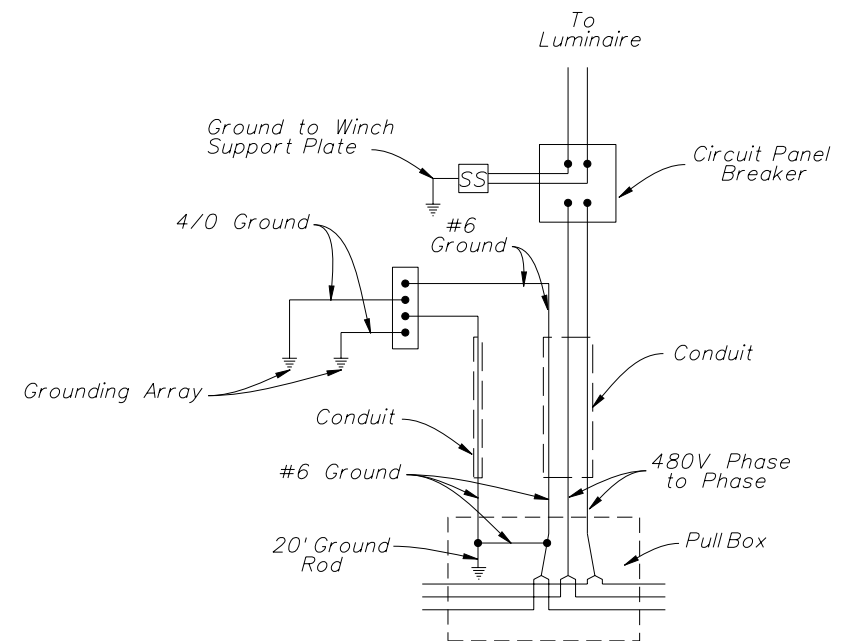

HIGH MAST POLE WIRING DIAGRAM

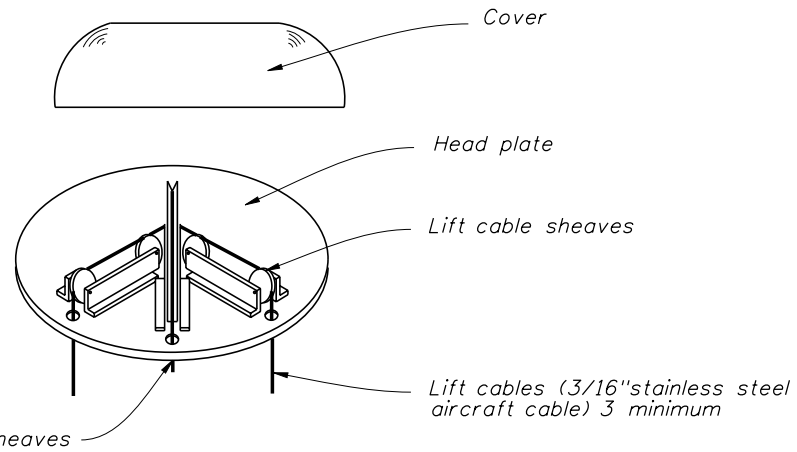
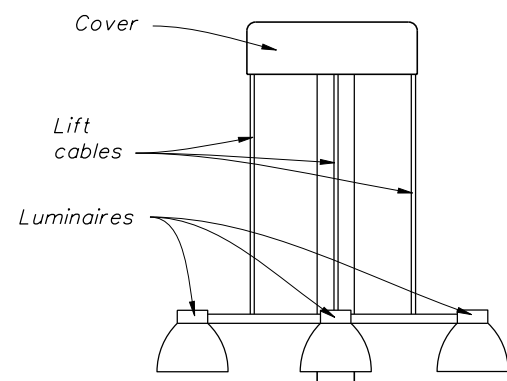

Spring supported centering arms provided to center the luminaire ring.

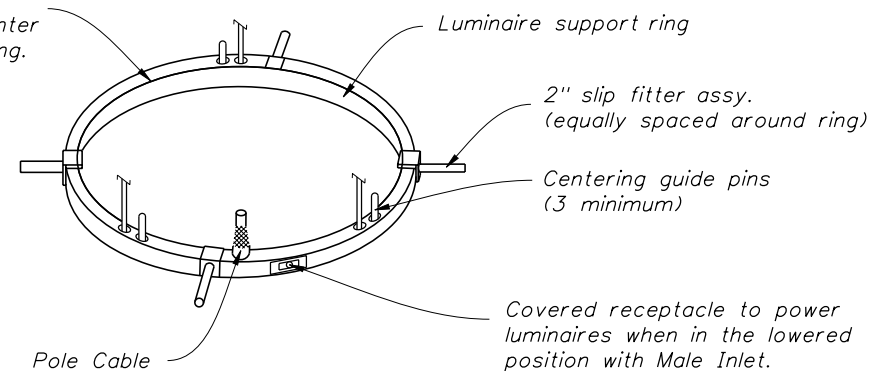
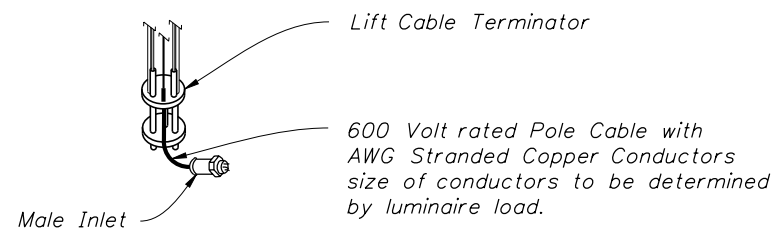

5/8" hex drive 3/4" round shaft

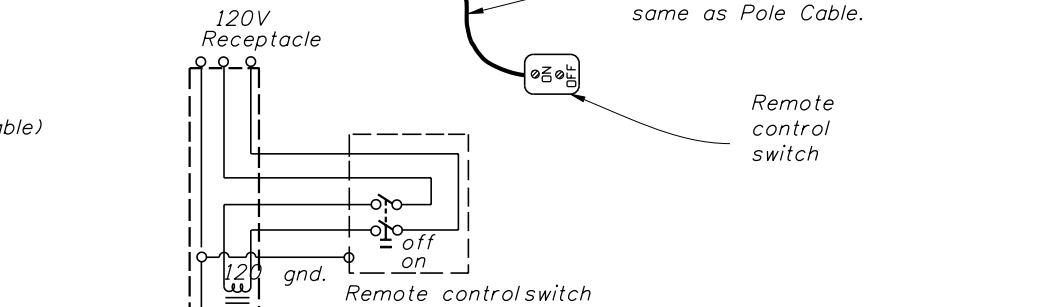
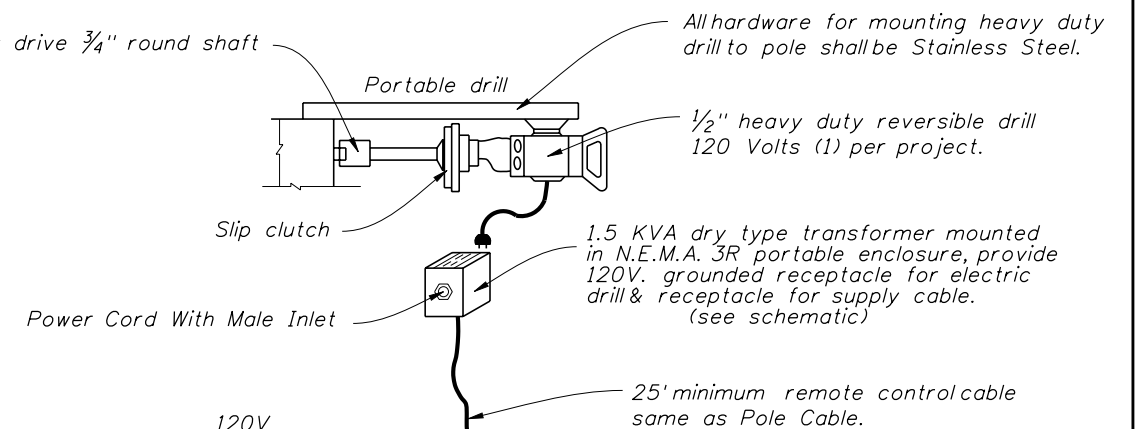

SCHEMATIC OF REMOTE AUXILIARY POWER UNIT

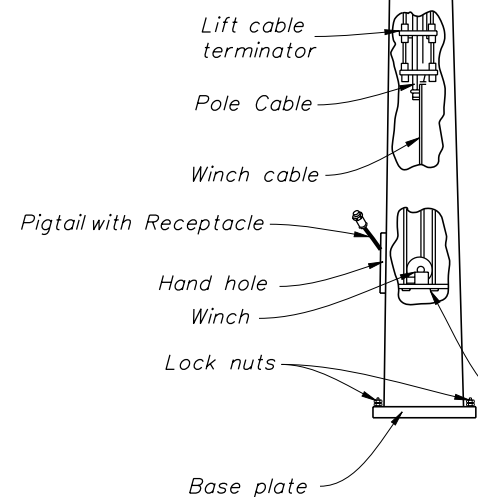

Positive drive reversible winch. The complete enclosed drum gear shall directly mesh with the worm gear train, in the same enclosure.

A surge protector shall be located in the pole with the circuit breaker. The surge protector shall be mounted at the front near hand hole for easy access.

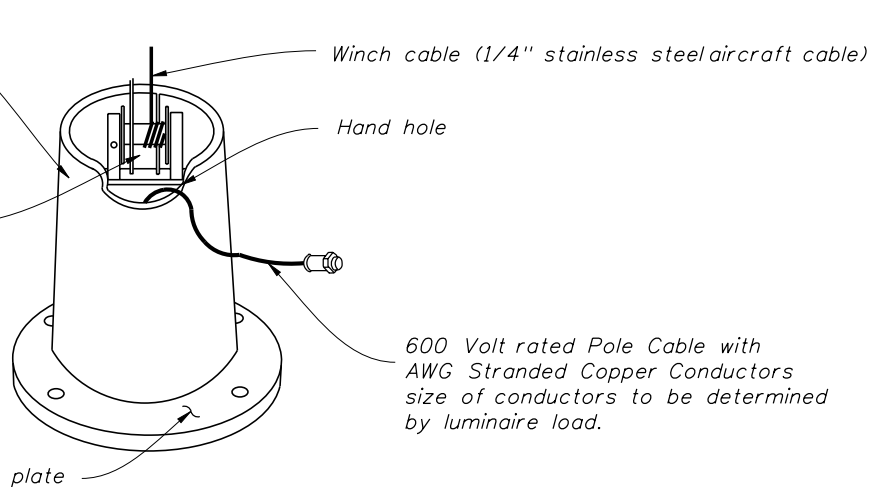

LOWERING DETAILS

REVISIONS

DATE	BY	DESCRIPTION	DATE	BY	DESCRIPTION
04/15/10	C.H.	HIGH MAST POLE WIRING DIAGRAM added to sheet.			

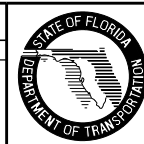

2010 Interim Design Standard

HIGHMAST LIGHTING

Interim Date	Sheet No.
07/01/10	2 of 7
Index No.	
17502	

HIGHMAST LIGHTING NOTES:

- 1) High Mast materials:
 - a. Pole: ASTM A1011 Grade 50, 55, 60 or 65 (Less than 1/4") or ASTM A572 Grade 50, 55, 60, or 65 (1/4" and over) or ASTM A595 Grade A (55 ksi yield) or Grade B (60 ksi yield).
 - b. Steel Plates: ASTM A709 Grade 36 or ASTM A36
 - c. Weld Metal: E70XX
 - d. Anchor Bolts: ASTM F1554 Grade 55 with ASTM A563, Grade A heavy-hex nuts and plate washer.
 - e. Handhole: ASTM A709 Grade 36 or ASTM A36 Frame with ASTM A36 cover.
 - f. Caps: ASTM A1011 Grade 50, 55, 60 or 65 or ASTM B209.
 - g. Nut Covers: ASTM B26 (319-F)
 - h. Stainless Steel Screws: AISI Type 316
- 2) Reinforcing steel: ASTM A615, Grade 60.
- 3) Concrete: Class IV (Drilled Shaft) with a minimum 4,000 psi compressive strength at 28 days for all environmental classifications.
- 4) Welding: American Welding Society Structural Welding Code (Steel) ANSI/AWS D1.1 (Current edition).
- 5) Galvanization:
 - a. Nuts, Bolts, Washers and Threaded Bars/Studs: ASTM F2329.
 - b. Other items (Including Pole): ASTM A123
- 6) Hole diameters for anchor bolts: not greater than the bolt diameter plus 1/2".
- 7) Poles: Tapered with the diameter changing at a rate of 0.14 inch per foot with a minimum 16-sided pole shaft and only one longitudinal seam weld. Circumferentially welded pole shaft butt splices and laminated pole shafts are not permitted. Longitudinal seam welds within 6 inches of pole to base must be complete penetration welds. Longitudinal seam welds at telescopic field joints must be complete penetration welds for the splice length plus 6 inches.
- 8) One hundred percent of full-penetration groove welds and a random 25 percent of partial penetration groove welds shall be inspected. Full-penetration groove weld inspection shall be performed by nondestructive methods of radiography or ultrasonics.
- 9) Furnish each pole with a 2"x4" (max.) aluminum identification tag. Submit details for approval. Secure to pole with 0.124" stainless steel rivets or screws. Locate identification tag on the inside of pole and visible from handhole. Include the following information: Financial Project ID, Pole Mounting Height, Manufacturer's Name, Certification Number and QPL Number.
- 10) Manufacturers seeking approval of a Highmast Lighting structural assembly (exclude lowering system) for inclusion on the Qualified Products List must submit a QPL Production Evaluation Application along with drawings showing the product meets all specified requirements of this Index.
- 11) Verify CSL access tubes will not interfere with anchor bolt installation before excavating the shaft. When CSL access tube locations conflict with anchor bolt locations, move the CSL access tube location ± two inches along the inner circumference of the reinforcing cage. Notify the Engineer before excavating the shaft if the CSL access tube locations cannot be moved out of conflict with anchor bolt locations.

DESIGN CRITERIA:

- 1) Designed in accordance with the FDOT Structures Manual.
- 2) Poles are designed to support the following:
 - a. (1) cylindrical head assembly with a maximum effective projected area of 6 Sq. ft. (Cd=1) and 340 lbs (Max).
 - b. (8) cylindrical luminaires with a maximum effective projected area of 3.0 Sq. ft (Cd=0.5) and 77 lbs. each.
- 3). Foundation design based upon the following soil criteria:
 - Classification = Cohesionless (Fine Sand)
 - Friction Angle = 30 Degrees (30°)
 - Unit Weight = 50 lbs./cu. Ft. (assumed saturated)

Only in cases where the Designer considers the soil types at the specific site location to be of lesser strength properties should an analysis be required. Auger borings, SPT borings or CPT soundings may be utilized as needed to verify the assumed soil properties, and at relatively uniform sites, a single boring or sounding may cover several foundations. Furthermore, borings in the area that were performed for other purposes may be used to confirm the assumed soil properties.
- 4) Foundation applies only to slopes of 1:4 or flatter. Provide a minimum 24" shaft projection on the high side.
- 5) Poles are designed for 6 mil galvanization thickness.

STANDARD POLE DESIGN NOTES

REVISIONS

DATE	BY	DESCRIPTION	DATE	BY	DESCRIPTION
07/01/10	DYW	Modified washer specification.			

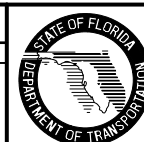

2010 Interim Design Standard

HIGHMAST LIGHTING

Interim Date

07/01/10

Sheet No.

3 of 7

Index No.

17502

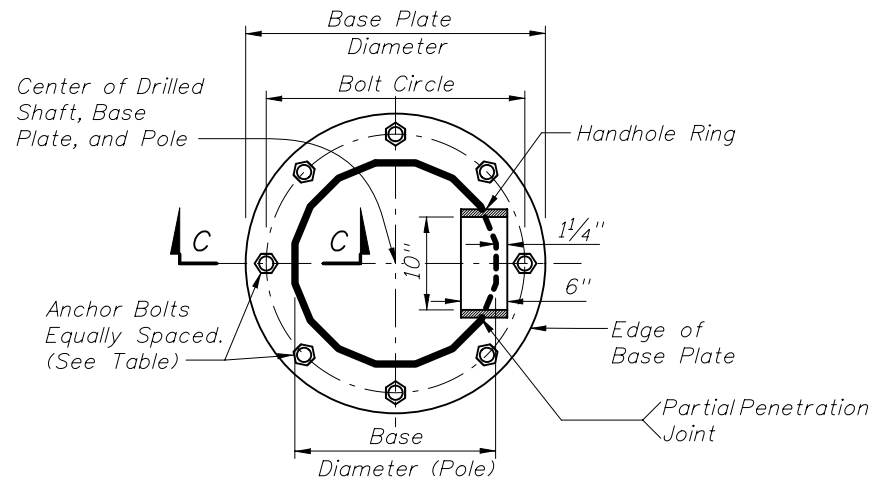

SECTION A-A

(T = Wall Thickness)

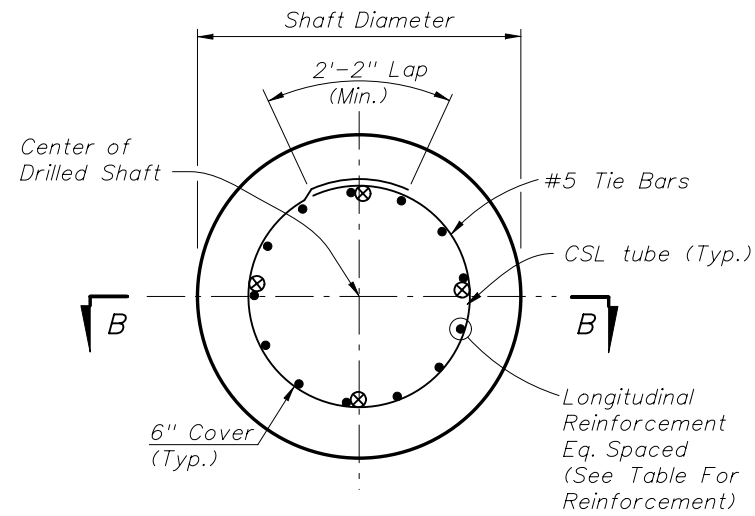

FOUNDATION PLAN
(Anchor Bolts and Conduits Not Shown)

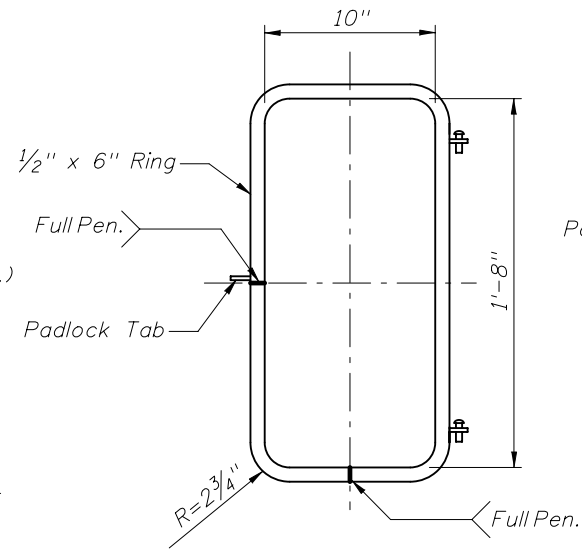

HANDHOLE RING

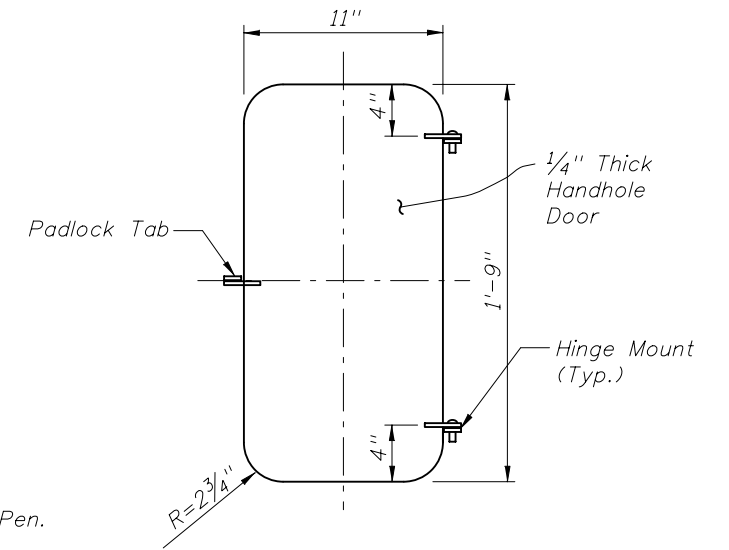

HANDHOLE DOOR

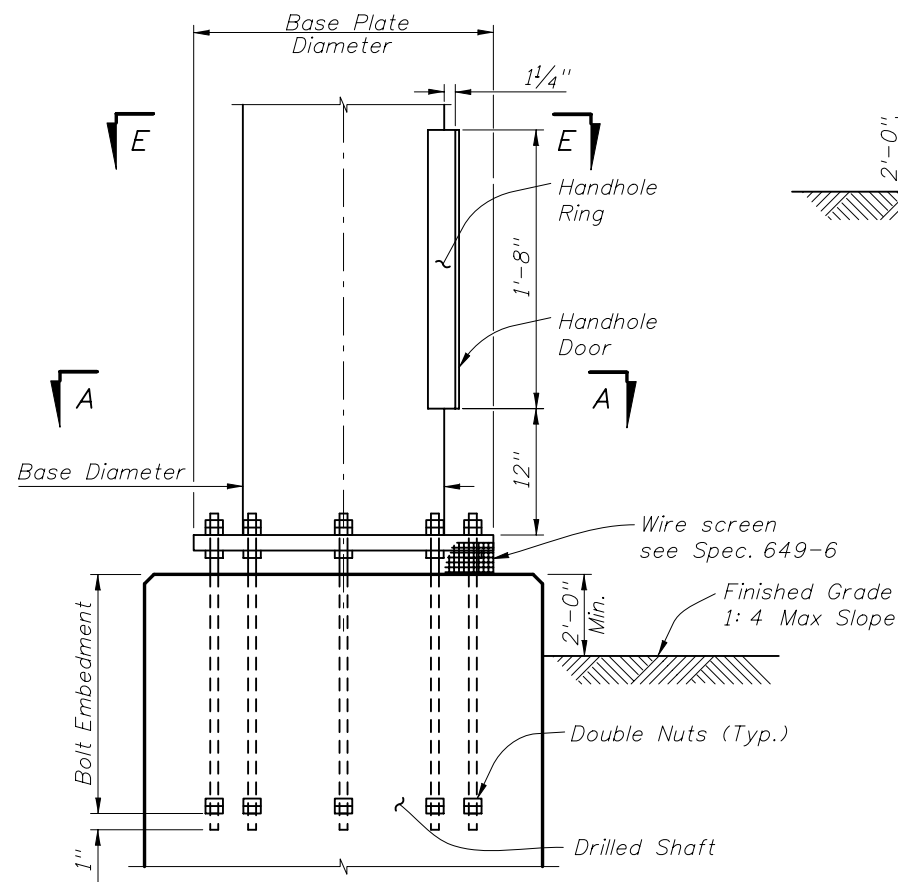

BASE PLATE AND ANCHORAGE ELEVATION

(Conduits Not Shown)

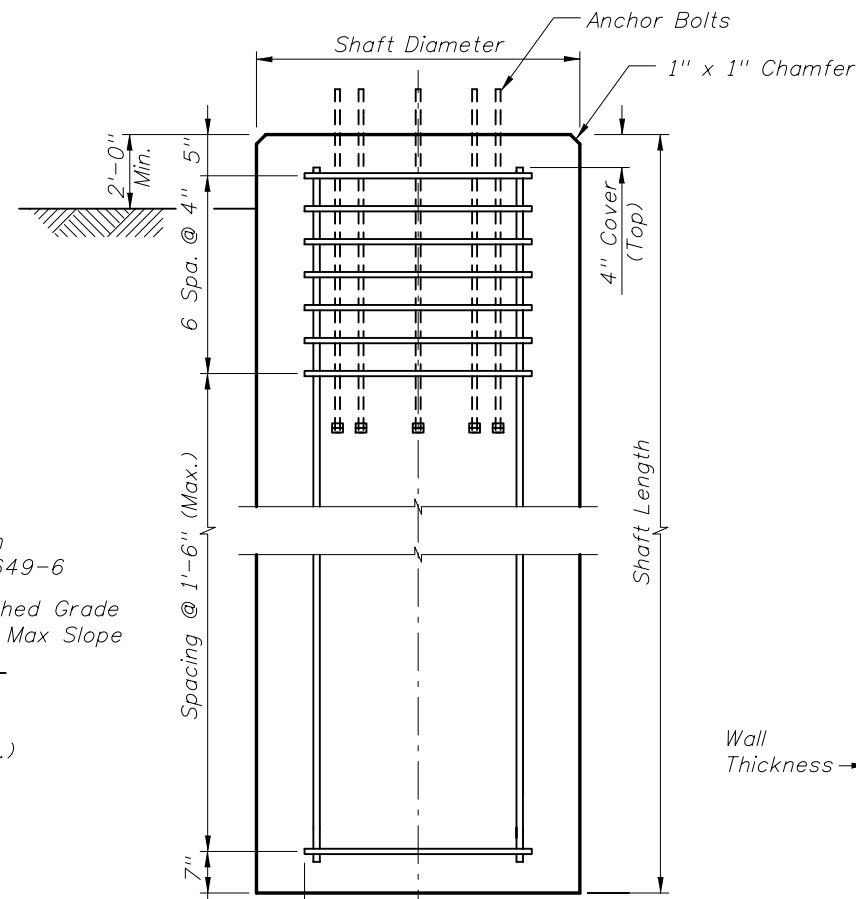

SECTION B-B

(Conduits Not Shown)

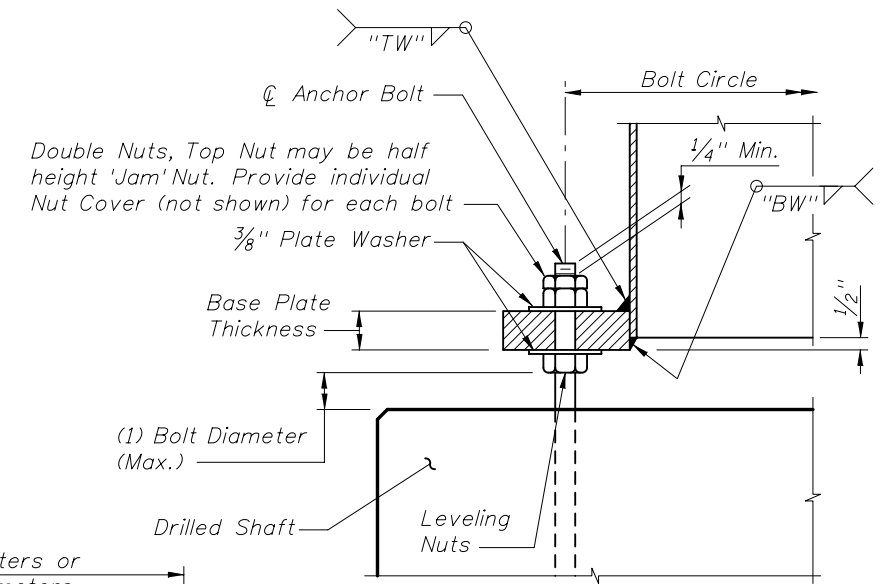

SECTION C-C

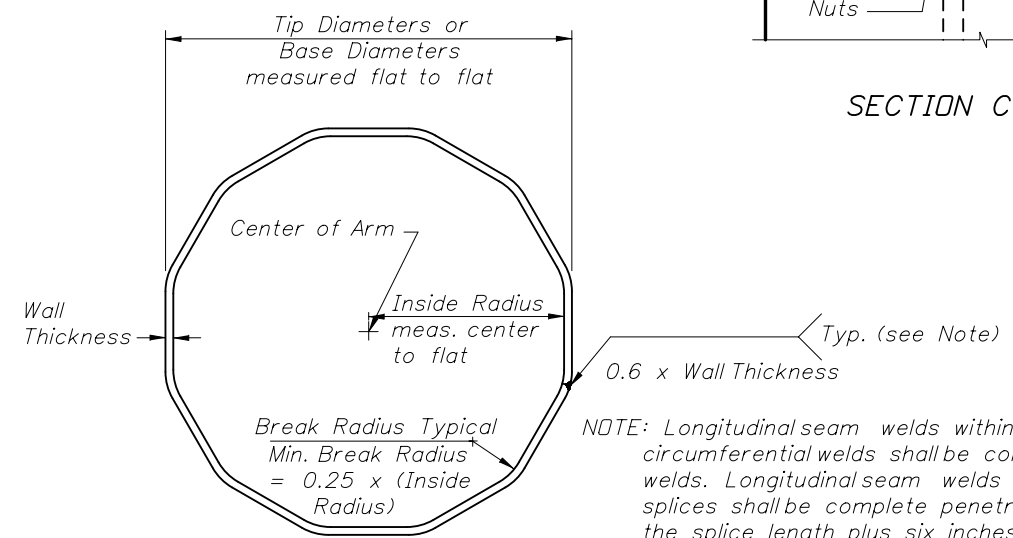

SECTION E-E

POLE FOUNDATION

REVISIONS

DATE	BY	DESCRIPTION	DATE	BY	DESCRIPTION
07/01/10	DYW	Modified longitudinal seam weld note & washer thickness.			

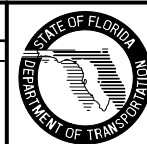

2010 Interim Design Standard

HIGHMAST LIGHTING

Interim Date

07/01/10

Sheet No.

5 of 7

Index No.

17502

NOTES:

1. Use compacted select material in accordance with Index 505.
2. Concrete shall be Class NS with a minimum strength at 28 days of $f'c=2.5$ ksi.
3. Outside edge of slab shall be cast against formwork.
4. The pull box shown is 1'-3" x 1'-3"; others approved under Section 635 of the Standard Specifications may be used.
5. Slabs to be placed around all Poles and Pull Boxes in rural locations. In urban areas or where space is limited slab dimensions may be adjusted as shown in the plans.
6. Concrete for slabs around poles and pull boxes shall be included in the price of pole or pull box.
7. The 1/2" thick expansion joint between the pole shaft and slab shall be sealed with a hot poured elastic joint sealer.

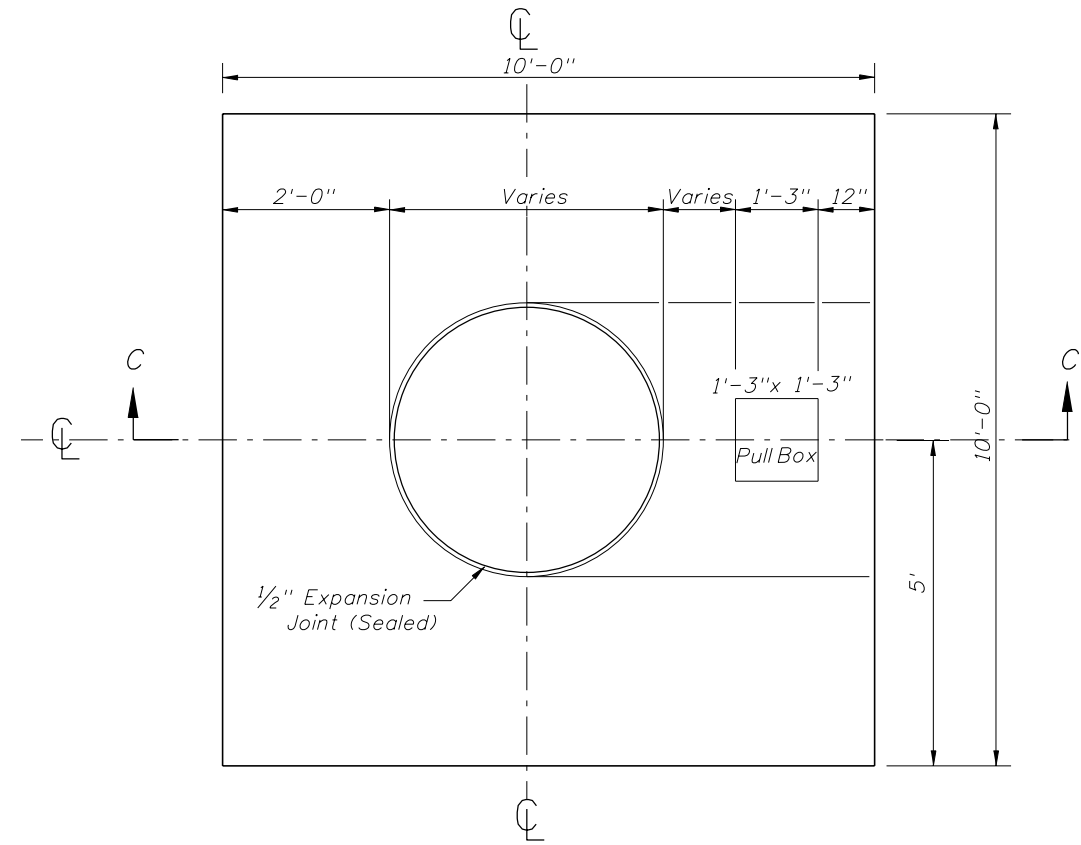

SLAB DIMENSIONS

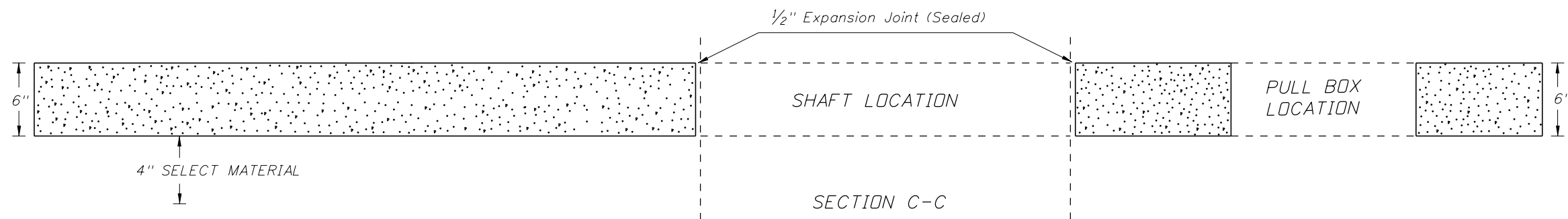

SLAB DETAILS

REVISIONS					
DATE	BY	DESCRIPTION	DATE	BY	DESCRIPTION
06/10/10	C.H.	Reinforcing removed from slab, notes revised, new dimensions were added to slab dimensions.			

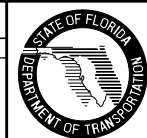

2010 Interim Design Standard

HIGHMAST LIGHTING

Interim Date	Sheet No.
07/01/10	7 of 7
Index No.	
17502	