

NOTES

DESIGN SPECIFICATIONS:

American Association of State Highway and Transportation Officials (AASHTO) "LRFD Bridge Design Specifications", Third Edition, 2004, including 75 year Design Life
 Florida Department of Transportation (FDOT) "Structures Design Guidelines for Load and Resistance Factor Design", January 2006.
 Florida Building Commission "Florida Building Code", 2004 Edition, except for Handrail diameter.
 U.S. Access Board "ADA Accessibility Guidelines", July 2004 as adopted with amendments by the USDOT under 49CFR Part 37.
 National Fire Protection Association (NFPA) 101, "Life Safety Code", 2003 Edition.

DESIGN LIVE LOADS:

Post and Base Plate: Equivalent point load = 200 lb. load + (50 lb./ft. x Post Spacing (ft.)) applied transversely at top rail connection.

Top & Bottom Rails: 50 lb./ft. uniform load applied simultaneously vertically and transversely + 200 lb. concentrated point load applied at midspan in the directions for both maximum stress and deflection.

Handrails: Maximum of either 50 lb./ft. uniform load applied in any direction or 250 lb. concentrated load applied in any direction at any point along the top.

Pickets: Concentrated 200 lb. load applied transversely over an area of 1.0 square foot.

GEOMETRY:

Clear Opening between Pickets: Shall reject the passage of a 4" diameter sphere below 42" height, and a 8" diameter sphere above 42" height.

Clear Opening under Bottom Rail: Shall reject the passage of a 2" diameter sphere.

ADA Handrail Height: 34"

Standard Pedestrian/Bicycle Railing Height: 42" minimum.

Special Height Bicycle Railing Height: 54" minimum.

DEFLECTION:

Total combined deflection of the railing system including the resilient or neoprene pads, due to the top rail design live loads, shall not exceed 1/2" when measured at midspan of the top rail.

APPLICABILITY NOTE TO DESIGNER:

This railing is not applicable for shielding drop-off hazards for vehicular traffic. This railing is applicable for all cases where a pedestrian or bicyclist drop-off hazard exceeds 2'-6" or when a drop-off hazard is less than 2'-6" and is required by design. See Index No. 861 for special requirements and modifications for use on bridges. Adequate foundation support shall be provided for anchorage and stability against overturning. For unusual site conditions a site specific railing is to be designed by the responsible engineer. The railing shown on these drawings requires a handrail for ramps steeper than a 5% grade to conform with the requirements of the Americans with Disabilities Act (ADA). Refer to FDOT Plans Preparation Manual (Volume I) Chapters 4 & 8, for the definition of vehicular, pedestrian and bicyclist "drop-off hazards".

ALTERNATE DESIGN:

Manufacturers seeking approval of proprietary railing systems for inclusion on the Qualified Products List as pre-approved alternate designs must submit application along with design documentation showing the proprietary railing system is designed to meet the design life, live loads, geometry and deflection requirements specified herein. All fixed joints are to be either welded or commercially designed fixed joint systems. Each field section of railing must be identified with a permanently affixed label with the manufacturer's name and the FDOT QPL approval number. Labels must be a maximum of 1 1/2" by 3" and located at the base of a post within the field section. Project specific shop drawings are required for QPL approved railings, see Shop Drawings note.

In lieu of design calculations, submit certified test reports from an approved independent testing agency. Test railing systems in accordance with ASTM E935 (Test Method A & C) using test loads at least 175% of the design load. Test proprietary or nonstandard anchorage systems in accordance with ASTM E894 (Flexural Test). Anchorage systems must resist the minimum of 175% of the design load for failure of the steel anchors or 220% of the design load for failure in the concrete foundation.

RAILS, PICKETS & POSTS:

Structural Tube, Pipe and Bar shall be in accordance with ASTM B221 or ASTM B429, Alloy 6061-T6. End Rail 90° bends and corner bends with maximum 4'-0" post spacing, may be Alloy 6063-T6. Posts and End Rails shall be fabricated and installed plumb, ± 1" tolerance when measured at 3'-6" above the foundation. Pickets shall be fabricated parallel to the posts. Corners and changes in tangential longitudinal alignment shall be made continuous with a 9" bend radius or terminate at adjoining sections with mitered end sections when handrails are not required. For changes in tangential longitudinal alignment greater than 45°, posts shall be positioned at a maximum distance of 2'-0" each side of the corner and shall not be located at the corner apex. For curved longitudinal alignments the top and bottom rails and handrails shall be shop bent to match the alignment radius.

RAILING MEMBER DIMENSIONS TABLE			
MEMBER	DESIGNATION	OUTSIDE DIMENSION	WALL THICKNESS
Posts	2" x 4" Rectangular Tube	2.00" x 4.00"	0.250"
Rails	2" NPS (Sch. 40)	2.375"	0.154"
Rail Joint/Splice Sleeves	1 1/2" NPS (Sch. 40)	1.900"	0.145"
Handrail Joint/Splice Sleeves	1" NPS (Sch. 40)	1.315"	0.133"
Handrails	1 1/2" NPS (Sch. 40)	1.900"	0.145"
Handrail Support Bar	1" Ø Round Bar	1.000"	N/A
Pickets	3/4" NPS (Sch. 40)	1.050"	0.113"

BASE PLATES & POST CAPS:

Base Plates and Post Cap plates shall be in accordance with ASTM B209, Alloy 6061-T6.

SHIM PLATES:

Shim Plates shall be aluminum in accordance with ASTM B209, Alloy 6061 or 6063. Shim plates shall be used for foundation height adjustments greater than 1/4" and localized irregularities greater than 1/8". Field trim shim plates when necessary to match the contours of the foundation. Beveled shim plates may be used in lieu of trimmed flat shim plates shown. Stacked shim plates must be bonded together with adhesive bonding material and limited to a maximum total thickness of 1/2", unless longer anchor bolts are provided for the exposed thread length.

COATINGS:

The aluminum railing shall be mill finish unless otherwise noted in the Contract Documents. All nuts, bolts and washers shall be hot-dip galvanized in accordance with Section 962 of the Specifications.

ANCHOR BOLTS:

Anchor bolts shall be in accordance with ASTM F1554 Grade 36. Headless anchor bolts for Adhesive Anchors shall be threaded full length. Cutting of reinforcing steel is permitted for drilled hole installation. Expansion Anchors are not permitted. All anchor bolts shall have single self-locking hex nuts. Tack welding of the nut to the anchor bolt may be used in lieu of self-locking nuts. All nuts shall be in accordance with ASTM A563 or ASTM A194. Flat Washers shall be in accordance with ASTM F436 and Plate Washers (for long slotted holes only), shall be in accordance with ASTM A36 or ASTM A709 Grade 36. After the nuts have been snug tightened, the anchor bolt threads shall be distorted to prevent removal of the nuts. Distorted threads and tack welds shall be coated with a galvanizing compound in accordance with the Specifications.

RESILIENT AND NEOPRENE PADS:

Resilient and Neoprene pads shall be in accordance with Specification Section 932 except that testing of the finished pads shall not be required. Neoprene pads shall be durometer hardness 60 or 70.

JOINTS:

All fixed joints are to be welded all around and ground smooth. Expansion joints shall be spaced at a maximum 35'-0". Field splices similar to the expansion joint detail may be approved by the Engineer to facilitate handling, but railing must be continuous across a minimum of two posts. Only use the Continuity Field Splice (Detail "E") to make the railing continuous for unforeseen field adjustments.

WELDING:

All welding shall be in accordance with the American Welding Society Structural Welding Code (Aluminum) ANSI/AWS D1.2 (current edition). Filler metal shall be either ER5183, ER5356 or ER5556. Nondestructive testing of welds is not required. Filler metal for picket welds may be ER4043.

SHOP DRAWINGS:

Complete details addressing project specific geometry (line & grade) showing post and expansion joint locations, anchor bolt installation "Case" or lengths, must be submitted by the Contractor for the Engineer's approval prior to fabrication of the railing. Shop drawings shall be in accordance with the Specifications.

PAYMENT:

Railing shall be paid for per linear foot (Item No. 515-2-abb). Payment will be plan quantity measured as the length along the center line of the top rail, and includes rails, posts, pickets, rail splice assembly, base plates, anchor bolts, nuts, washers, resilient or neoprene pads and all incidental materials and labor required to complete installation of the railing.



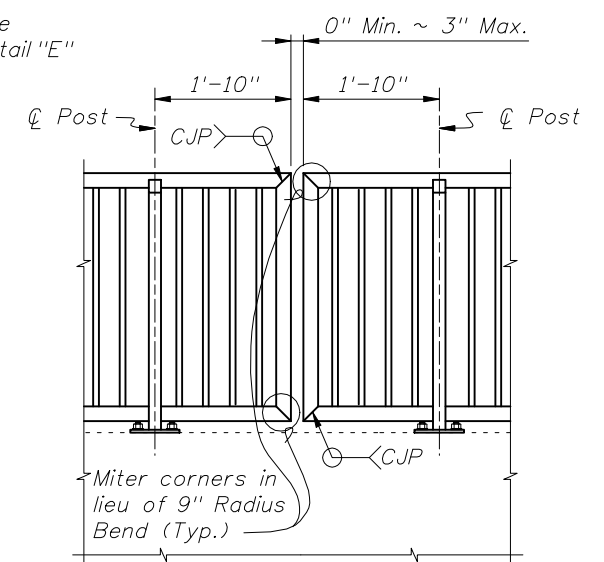
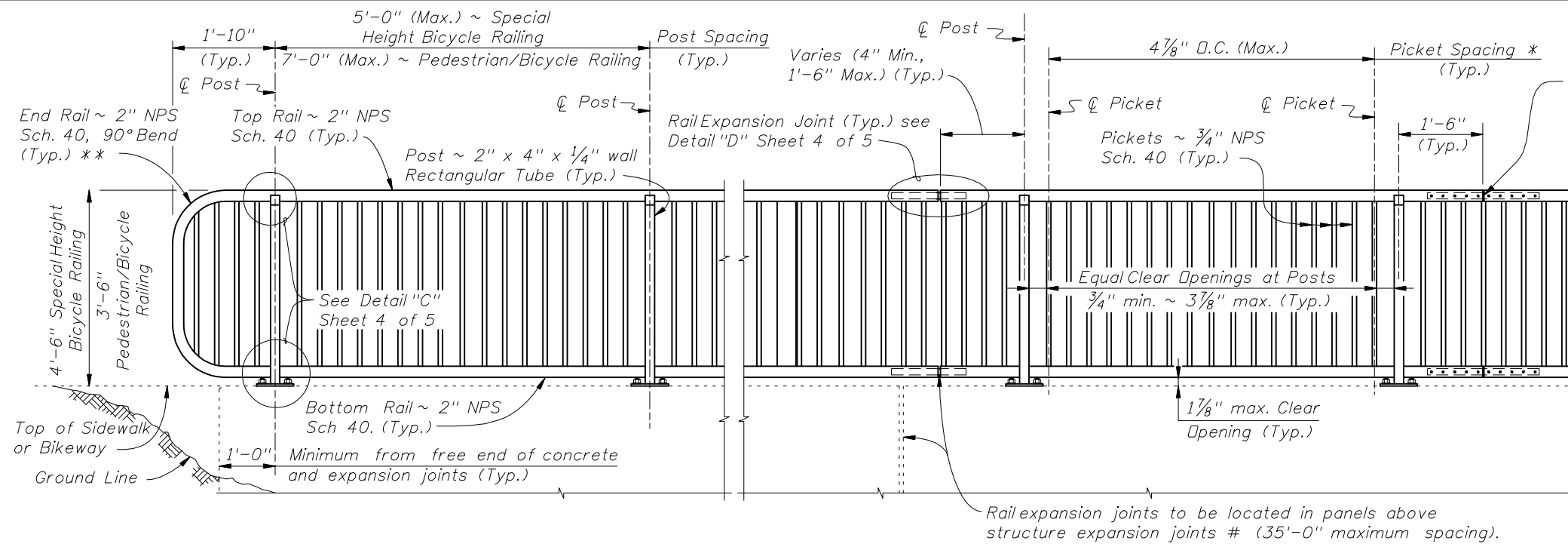

ELEVATION
(Showing Outside Face of Railing)

EXPANDED ELEVATION AT CORNERS

TYPICAL RAILING DETAILS & RAILINGS ON GRADES 0% TO 5%

DETAIL FOR NON-CONTINUOUS RAILING AT CORNERS

NOTES:
 * Picket Spacing of 4 7/8" centers is based on a 3/4" NPS. If an alternate design is used maintain a maximum clear opening of 3 7/8".
 ** End Rail bend varies for Railings on grades steeper than 2.4%.
 NPS = Nominal Pipe Size

STRUCTURES EXPANSION JOINTS NOTE:
 # Keyed construction joints in Index No. 520 Gravity Wall are not considered to be expansion joints.
 CROSS REFERENCE:
 For Details "C", "D" and "E", see Sheet 4 of 5.

Handrail required for ramps (Handrail continuous at landings between runs)
 Handrail ~ 1 1/2" NPS Sch. 40

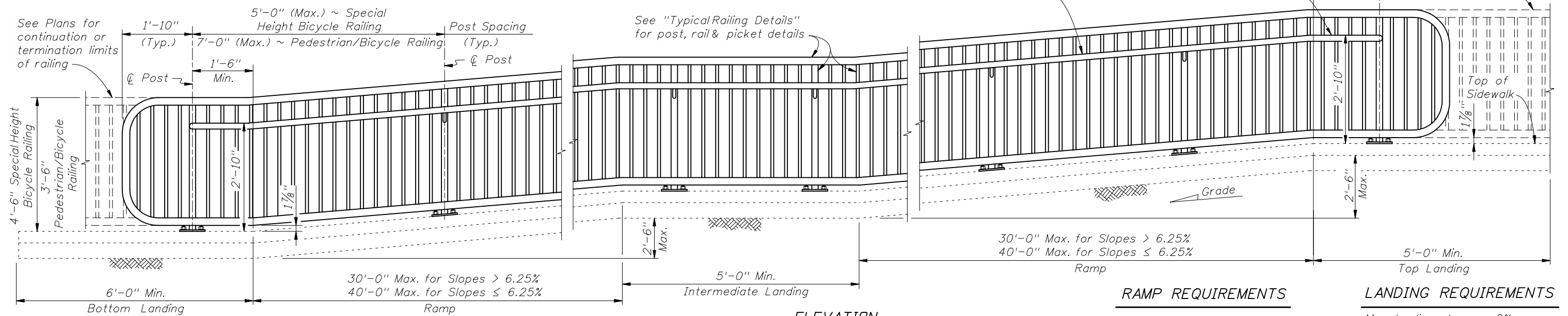

ELEVATION
(Showing Inside Face of Railing)

RAMP REQUIREMENTS
 For slopes greater than 5%:
 Max. ramp slope = 8.33%
 Max. ramp cross-slope = 2.0%

LANDING REQUIREMENTS
 Max. landing slope = 2%
 Max. landing cross-slope = 2%

RAILINGS ON GRADES STEEPER THAN 5% TO 8.33%

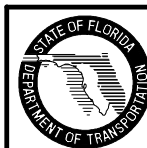

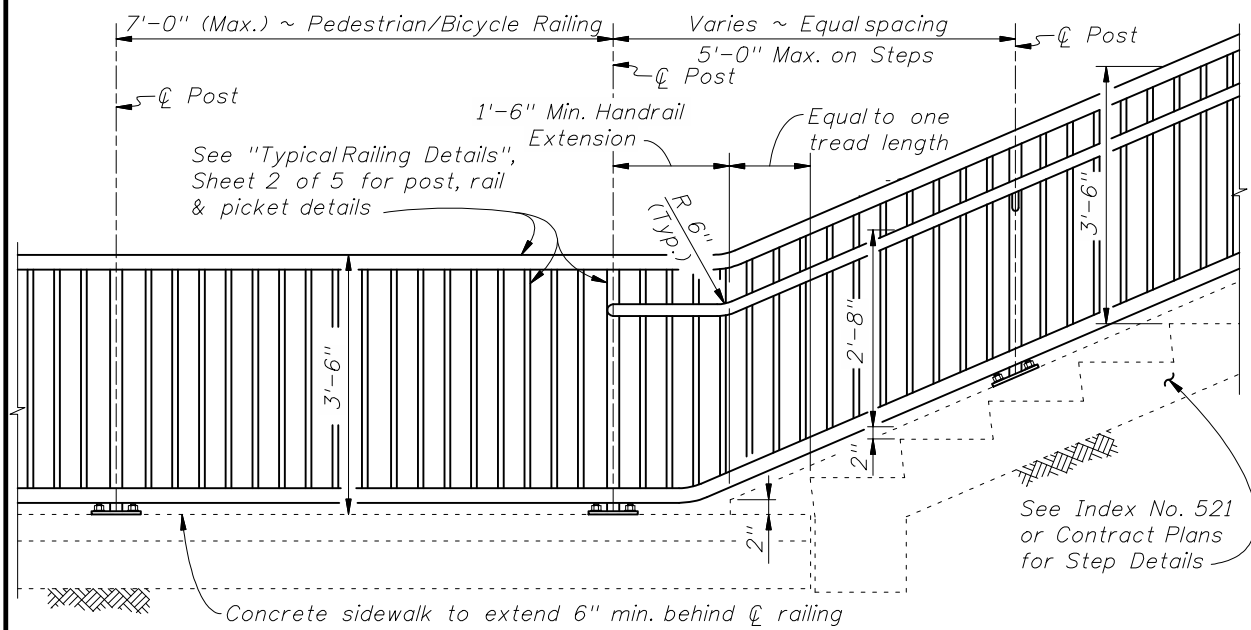

RAILING CONTINUATION BEYOND STEPS OR STAIRS
(Bottom shown, Top similar)

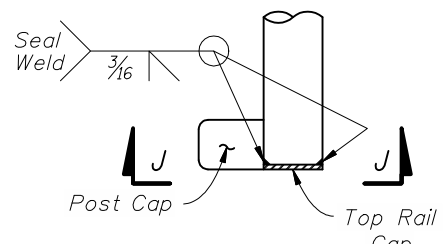
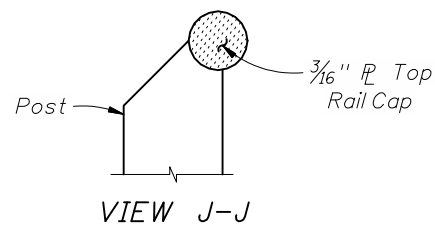

DETAIL "J" - PLAN VIEW
TOP RAIL TERMINATION

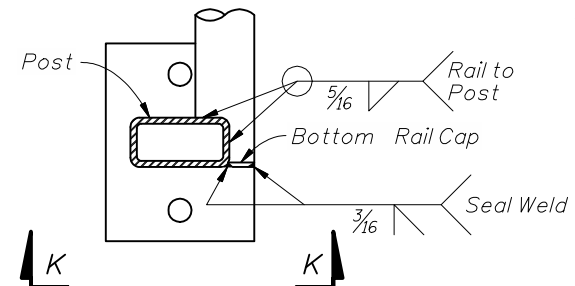
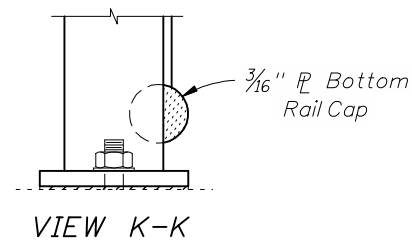

DETAIL "K" - PLAN VIEW
BOTTOM RAIL TERMINATION

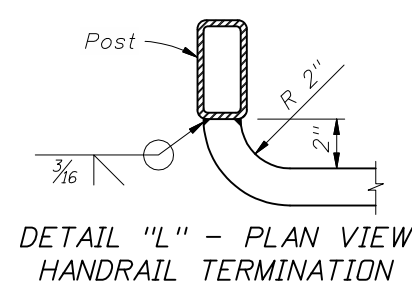

ALTERNATE END TREATMENT DETAILS

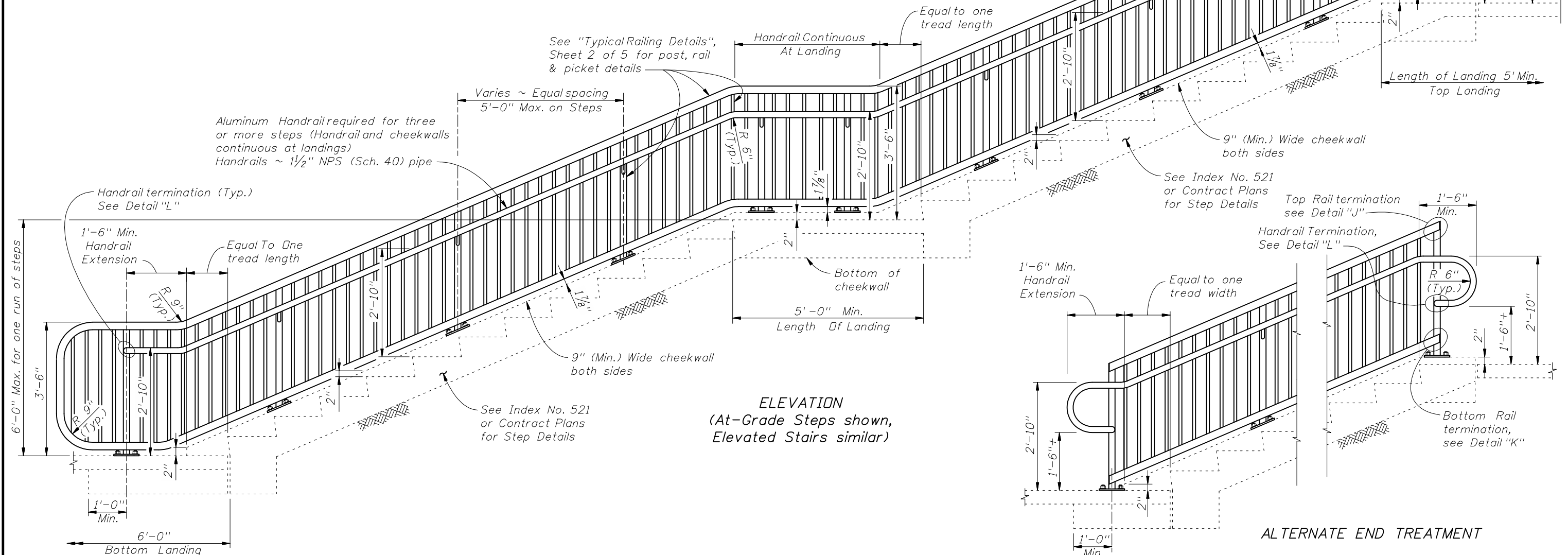

ELEVATION
(At-Grade Steps shown,
Elevated Stairs similar)

ALTERNATE END TREATMENT

RAILINGS ON STEPS & STAIRS

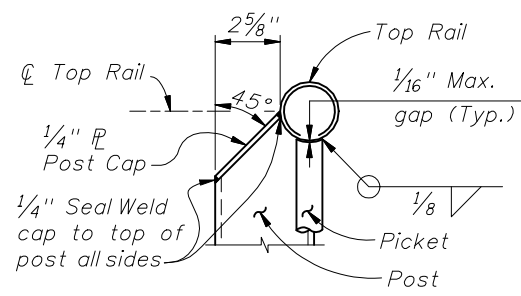

TYPE A (WELDED)

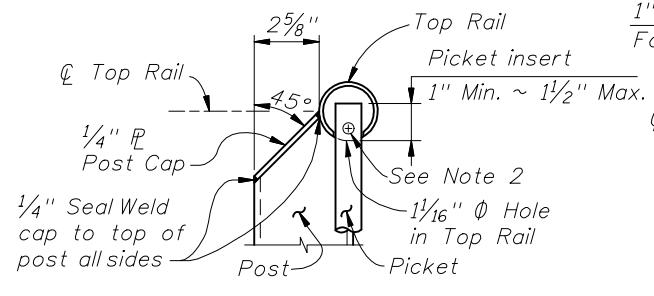

TYPE B (NONWELDED)

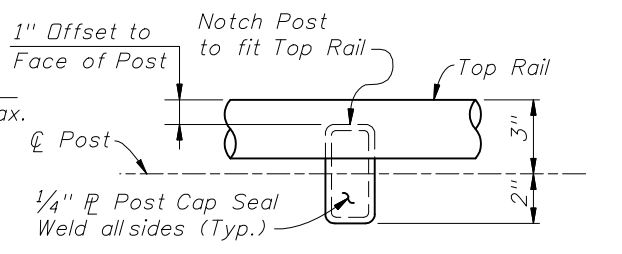

VIEW F-F
TOP RAIL CONNECTION
(Base Plate Not Shown for Clarity)

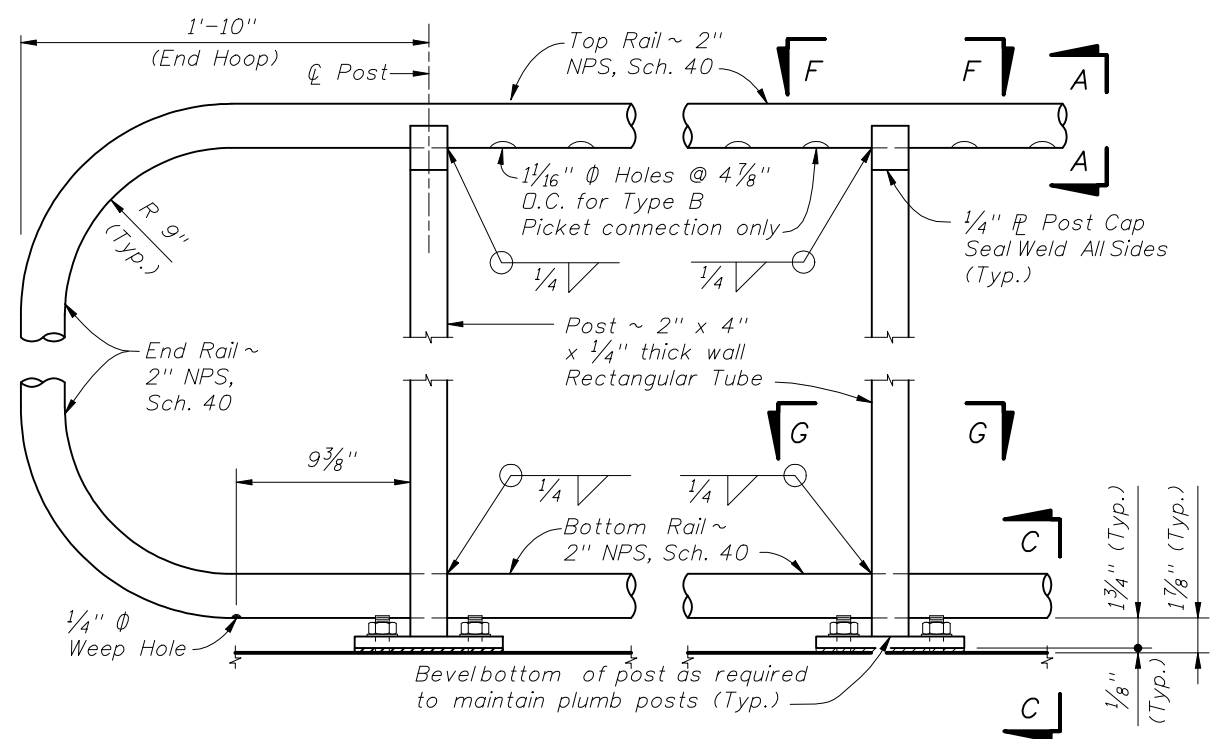

DETAIL "C" - RAIL CONNECTIONS
(Showing Outside Face of Structure and Railing,
Pickets and Handrail Not Shown for Clarity)

SECTION A-A
(Top of Picket Connection)

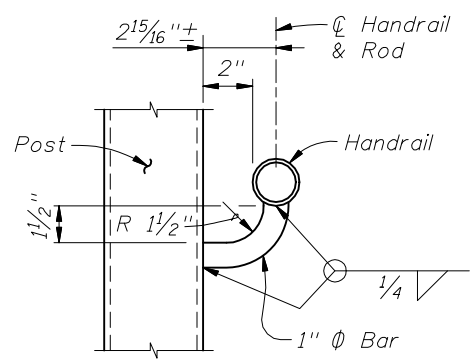

SECTION B-B
(Handrail Connection)

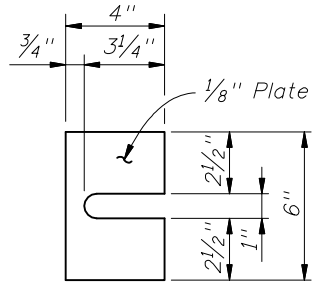

SHIM PLATE
DETAIL

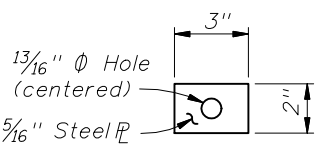
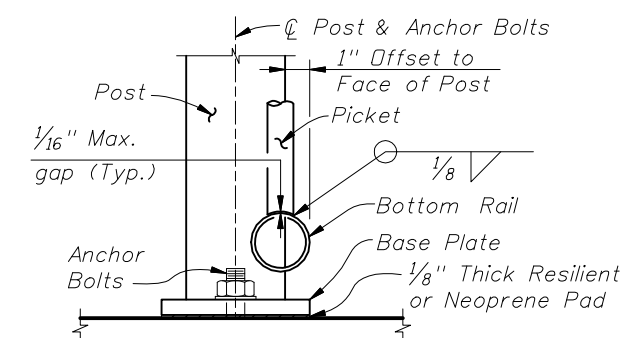
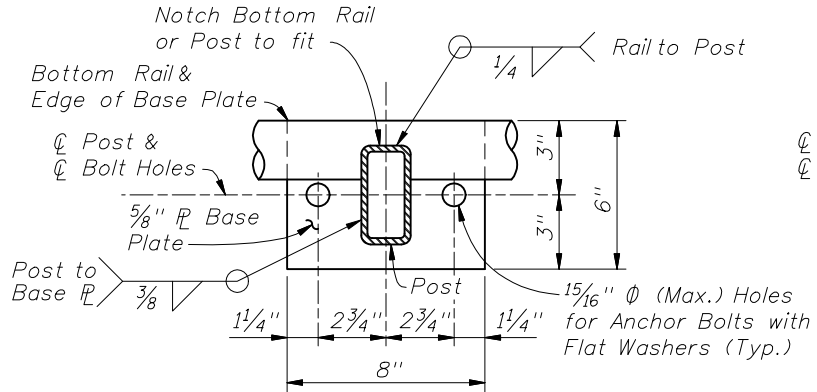

PLATE WASHER
DETAIL

- Notes:
1. Type B connection is required for use with Index No. 861 on bridges, except End Hoops may use Type A connections. Optional for other installations and for connection to bottom rail.
 2. Provide #10 x 1/2" Pan Head Stainless Steel (316 or 18-8 Alloy) Screw in the last picket at each expansion or field splice joint to secure the end of the top rail.



SECTION C-C
(Bottom of Picket connection)



SECTION G-G
BASE PLATE & BOTTOM RAIL CONNECTION

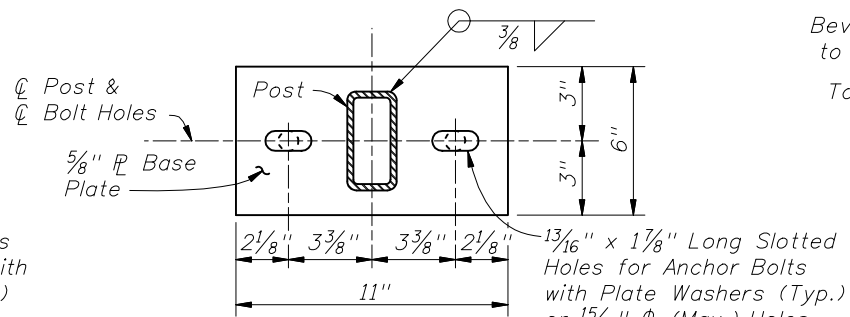

ALTERNATE
BASE PLATE DETAIL
(Recommended for Top of Step Cheekwalls)

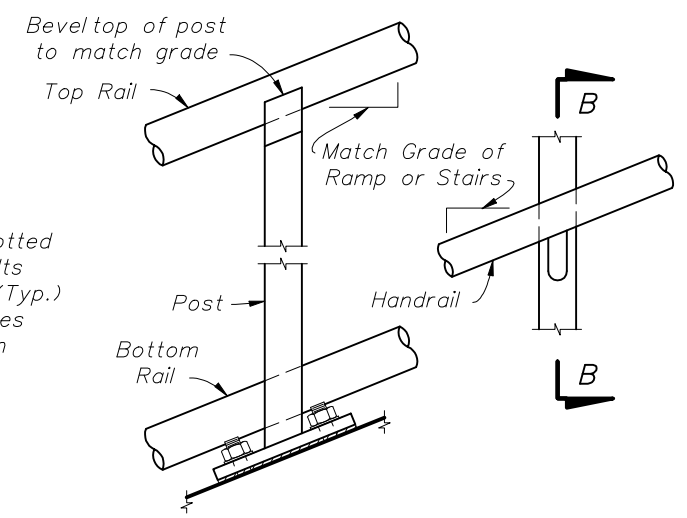

DETAIL "B" - RAIL AND HANDRAIL
(Showing Sloped Condition for Stairs or Ramp)

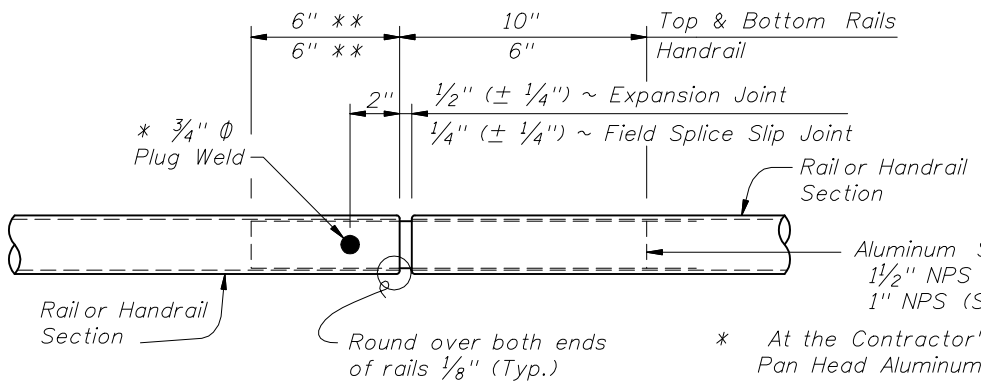

DETAIL "D" - EXPANSION JOINT
(FIELD SPLICE SLIP JOINT SIMILAR)

- * At the Contractor's option 2 ~ 1/4" x 3/4" Pan Head Aluminum (Alloy 2024-T4 or 7075-T73) or Stainless Steel (Type 316 or 18-8 Alloy) Set Screws at 2" spacing may be substituted for the 3/4" diameter plug weld. Set screws must be set flush against the outside face of rails and underside of handrails.
- ** Embedded length may be 4" for plug welded connection.

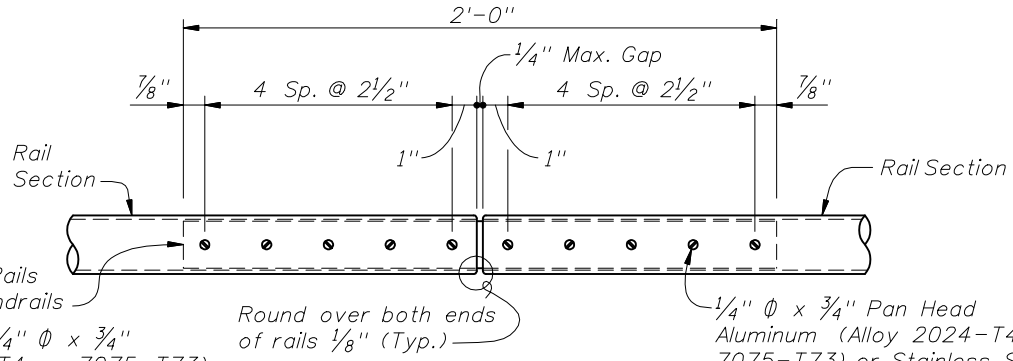

DETAIL "E" - CONTINUITY
FIELD SPLICE

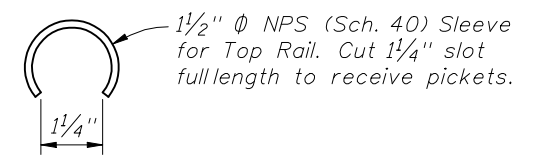

SLEEVE MODIFICATION FOR
TOP RAIL TYPE B CONNECTION

CROSS REFERENCE:
For locations of Details "C", "D" and "E", see Sheet 2 of 5.

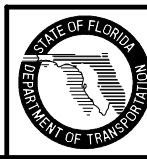

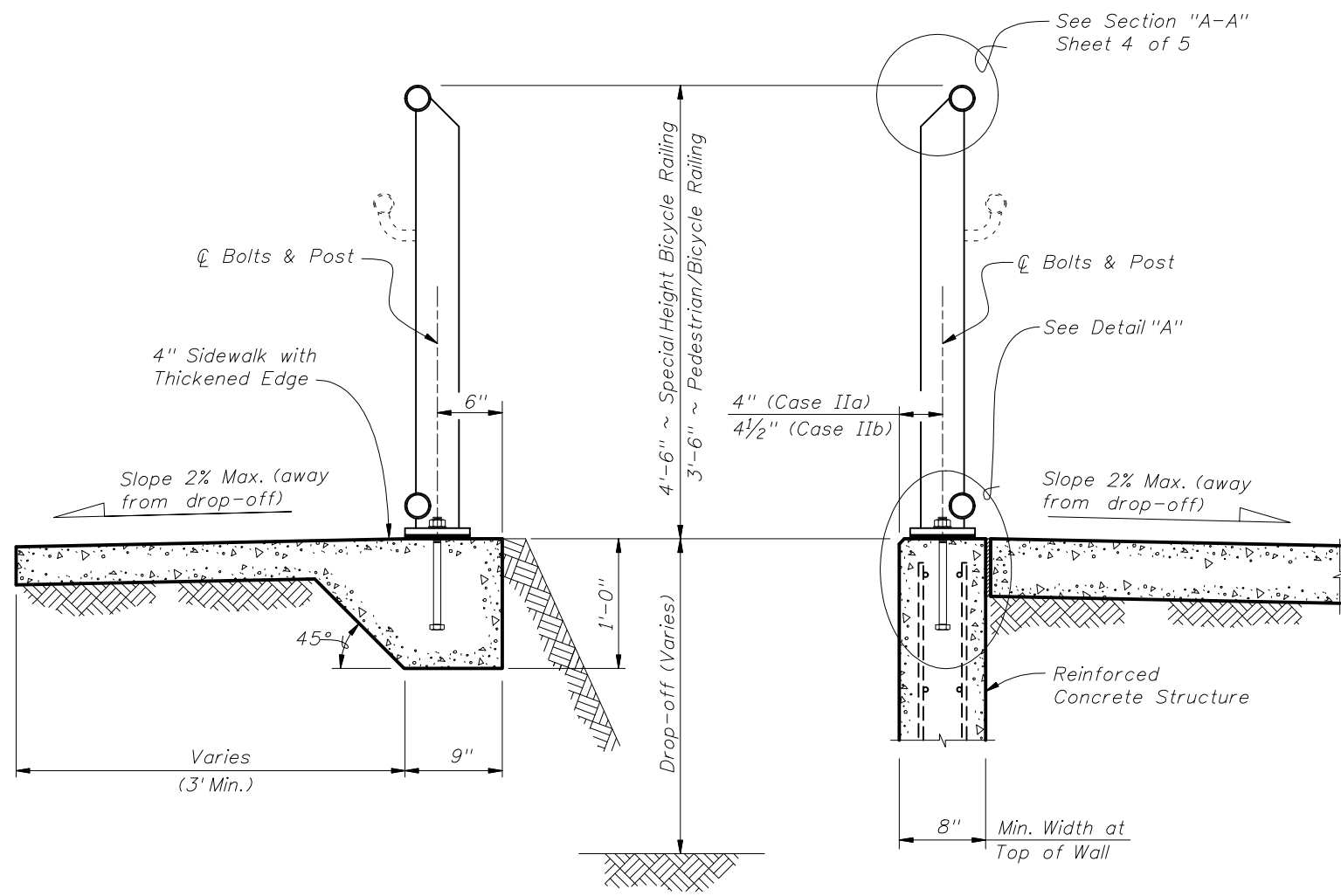

TYPICAL SECTION ON CONCRETE SIDEWALK (Case I)

TYPICAL SECTION ON RETAINING WALL (Case II)

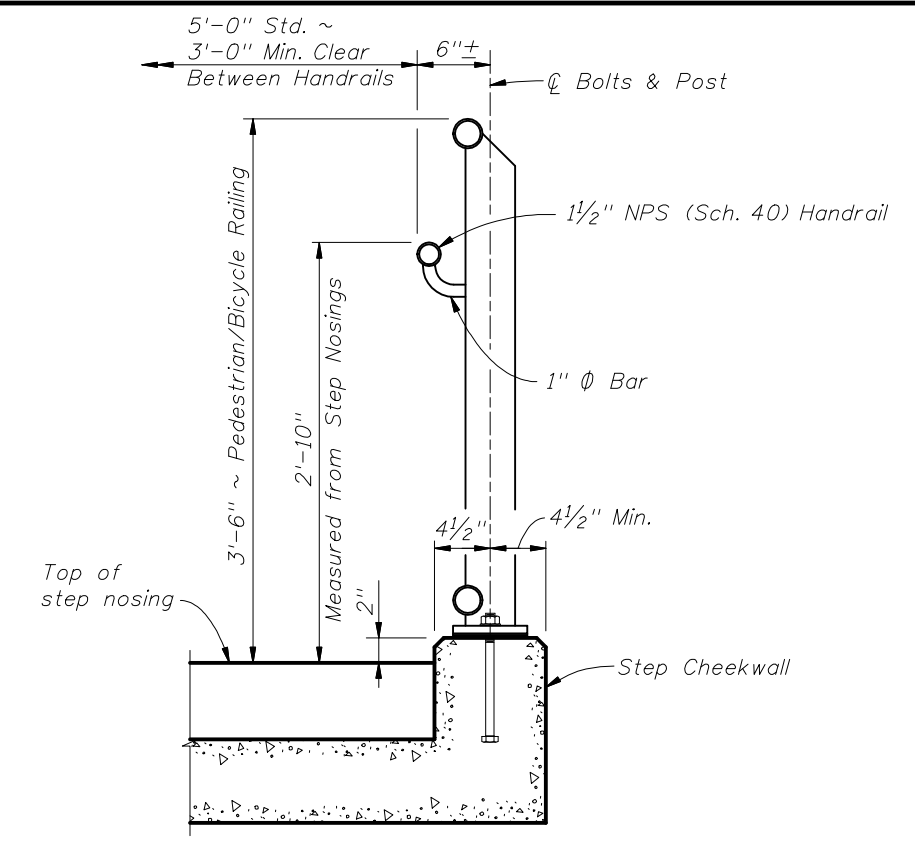

TYPICAL SECTION ON STEPS & STAIRS (Case III)

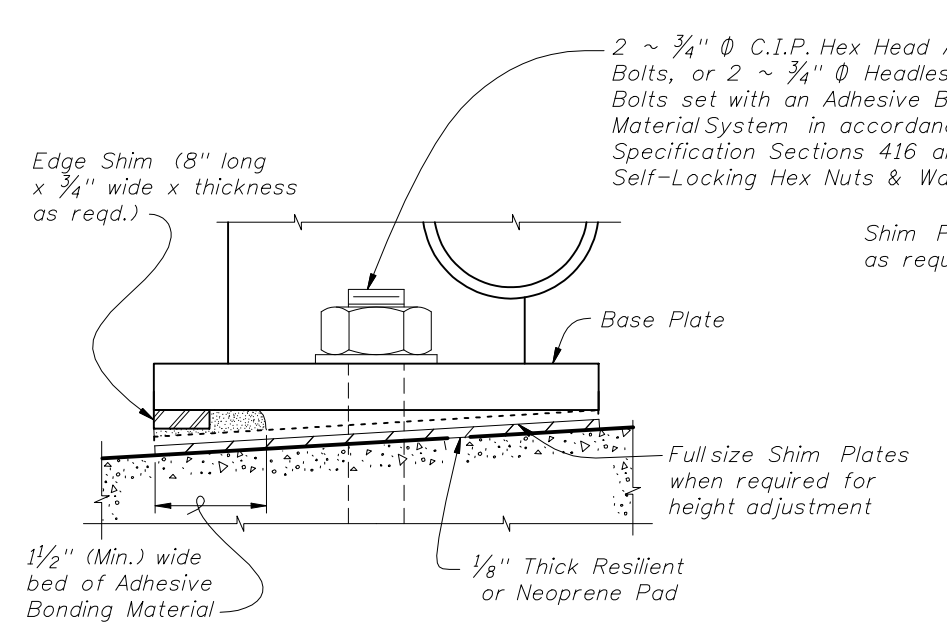

DETAIL "F" (OPTIONAL SHIMMING DETAIL FOR CROSS SLOPE CORRECTION) (Used in lieu of Beveled Shim Plates)

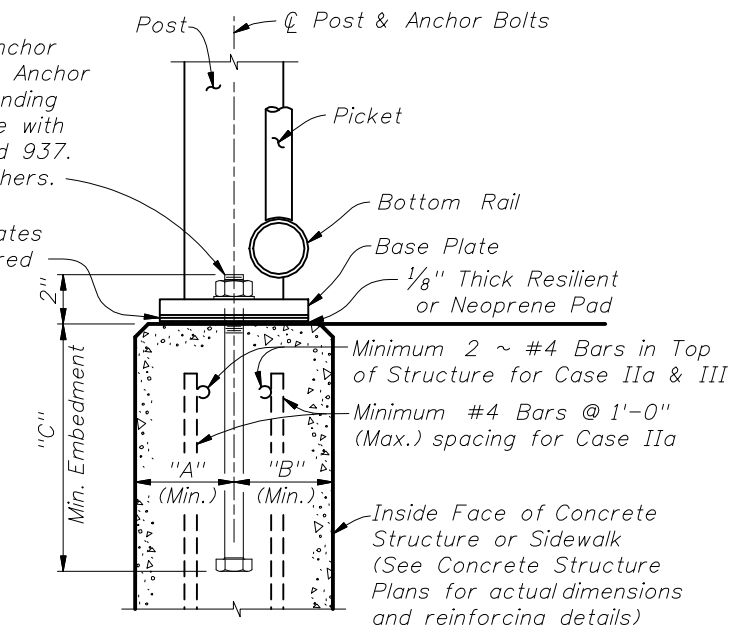

DETAIL "A" (Cast-In-Place Anchor Bolts shown, Adhesive Anchors similar)

ANCHOR BOLT TABLE							
CASE	STRUCTURE TYPE	DIMENSIONS			ANCHOR LENGTH		ANCHOR SIZE
		"A" Edge Dist.	"B" Edge Dist.	"C" Embedment	C.I.P. Hex Head Bolt	Adhesive Anchor	
I	Unreinforced Concrete	6"	1'-2"	9"	10 1/2"	11"	3/4" ϕ
IIa	Reinforced Concrete	4"	4"	9"	10 1/2"	11"	3/4" ϕ
IIb	Gravity Wall Index No. 520	4 1/2"	3 1/2" @ top	1'-0" *	1'-1 1/2"	1'-2"	3/4" ϕ
III	Step Cheekwall	4 1/2"	4 1/2"	9"	10 1/2"	11"	3/4" ϕ

* Embedment length "C" may be reduced to 9" for the 3'-6" height railings for Case IIb, when the post spacing does not exceed 5'-0".

