

Aluminum Identification Tag Not To Exceed 2" x 4". Secure To Pole By 0.125" Stainless Steel Rivets Or Screws. Fabricators To Provide Details For Approval. Identification Tag Located On Inside Of Pole Visible From Handhole, Or On Outside Of Pole Inside Terminal Compartment. Tag To Be Stamped With The Following Information :

Standard Design	Special Design
Financial Project ID	Financial Project ID
Pole Type	Pole Base Diameter (in.)
Arm Type	Pole Wall Thickness (in.)
Manufacturer's Name	Arm Diameter at Pole (in.)
Certification No.	Arm Wall Thickness (in.)
QPL No.	Manufacturer's Name

MAST ARM ASSEMBLIES GENERAL NOTES

- Signal Structure Materials shall be as follows:
 - Poles & Mast Arms → ASTM A1011 Grade 50, 55, 60 or 65 (less than 1/4") or ASTM A572 Grade 50, 55, 60 or 65 (1/4" and over) or ASTM A595 Grade A (55 ksi yield) or Grade B (60 ksi yield)
 - Steel Plates → ASTM A36
 - Weld Metal → E70XX
 - Bolts (except Anchor Bolts) → ASTM A325 Type 1
 - Anchor Bolts → ASTM F1554 Grade 55 ksi
 - Nuts for Anchor Bolts → ASTM A563 Grade A Heavy Hex
 - Washers for Anchor Bolts → ASTM F436 Type 1
 - Handhole Frame → ASTM A709 Grade 36 ksi or ASTM A36
 - Handhole Cover → ASTM A1011 Grade 50, 55, 60 or 65 ksi
 - Caps → ASTM A1011 Grade 50, 55, 60 or 65 ksi or ASTM B209
 - Nut Covers → ASTM B26 (319-F)
 - Stainless Steel Screws → AISI Type 316
 - Threaded Bars/Studs → ASTM A36 or ASTM A307
- Reinforcing Steel shall be ASTM A615 Grade 60 ksi.
- Concrete shall be Class IV (Drilled Shaft) with a minimum 28-day compressive strength of 4,000 psi for all environmental classifications.
- All welding shall conform to American Welding Society Structural Welding Code (Steel) ANSI/AWS D1.1 (current edition).
- All steel items shall be galvanized as follows:
 - All Nuts, Bolts, Washers and Threaded Bars/Studs → F2329
 - All other steel items (including Pole & Mast Arm) → ASTM A123
- Locate handhole 180° from arm on single arm poles or 180° from first arm of double arm poles or see special instructions on Mast Arm Tabulation Sheet.
- Except for Anchor Bolts, all bolt hole diameters shall be equal to the bolt diameter plus 1/16", prior to galvanizing. Hole diameters for Anchor Bolts shall not exceed the bolt diameter plus 1/2".

- Sign Panels and Signals attached to the Mast Arm shall be centered in elevation on the arm. Sign Panels shall be aluminum. Wire access holes shall not exceed 1 1/2" in diameter.
- Mast Arms and Poles shall be tapered with the diameter changing at a rate of 0.14 inch per foot.
- The Pole shall be installed vertically. Camber shall be accounted for in the Mast Arm connection as detailed.
- If a Mast Arm damping device is required by the Engineer, it shall be installed within eight feet of the Mast Arm tip.
- Design according to FDOT Structures Manual (current edition). Alternate Designs for Special Mast Arm Assemblies are not allowed.
- Provide "J", "S" or "C"-Hook at top of pole for signal cable support.
- First and Second Arm Camber Angle = 2°.
- Details for the Ground Rod, Signal and Sign Locations, Signal Head attachment, Sign Attachment, Pedestrian Head Attachment, and Foundation Conduit are not shown for clarity.
- One hundred percent of full-penetration groove welds and a random 25 percent of partial penetration groove welds shall be inspected. Full-penetration groove weld inspection shall be performed by nondestructive methods of radiography or ultrasonics.
- Manufacturers seeking approval of a steel mast arm assembly for inclusion on the Qualified Products List must submit a QPL Product Evaluation Application along with design documentation and drawings showing the product meets all specified requirements of this Index and Index 17743.
- Verify CSL access tubes will not interfere with anchor bolt installation before excavating the shaft. When CSL access tube locations conflict with anchor bolt locations, move the CSL access tube location +/- two inches along the inner circumference of the reinforcing cage. Notify the Engineer before excavating the shaft if the CSL access tube locations cannot be moved out of conflict with anchor bolt locations.

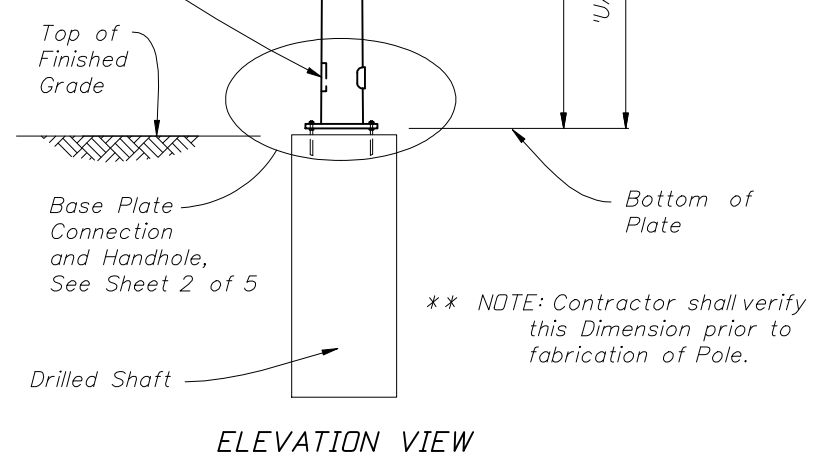

ELEVATION VIEW

(Single Arm Shown, Double Arm Similar)
(Luminaire Arm Not Shown)

** NOTE: Contractor shall verify this Dimension prior to fabrication of Pole.

TYPICAL ELEVATION AND NOTES

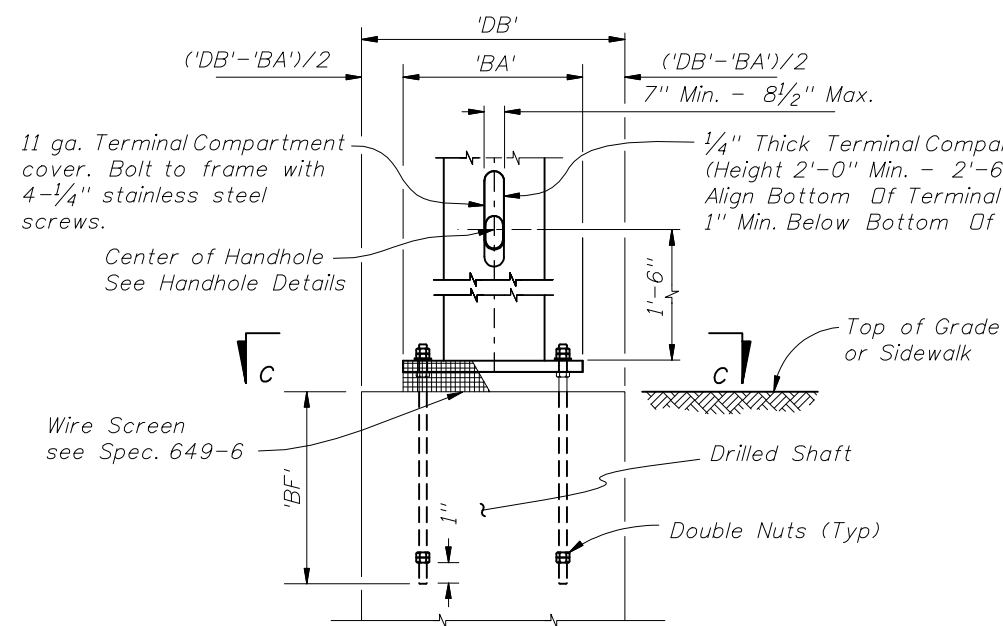

BASE PLATE AND ANCHORAGE ELEVATION
(Reinforcement Not Shown)

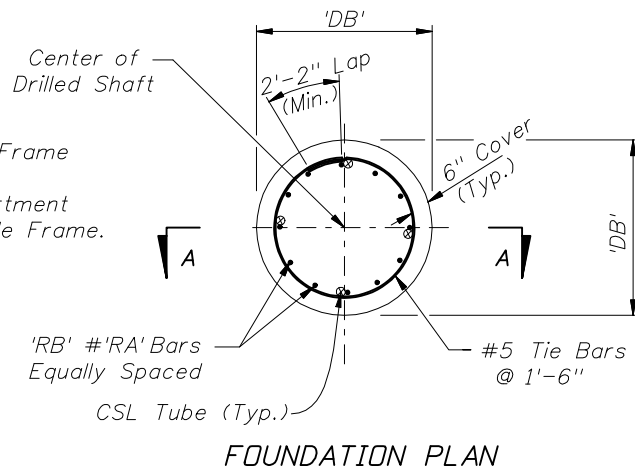

FOUNDATION PLAN

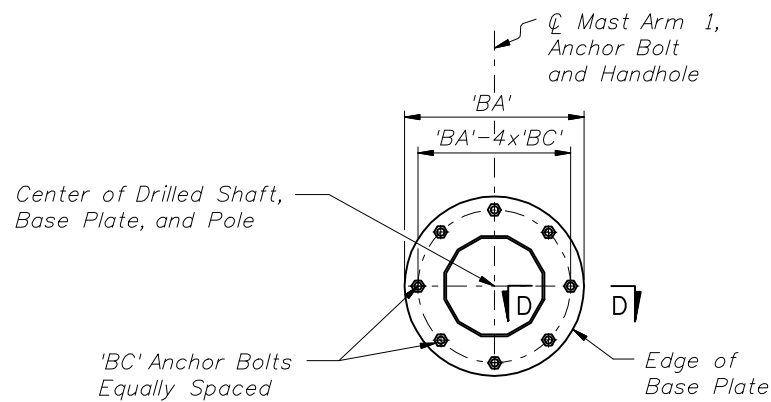

SECTION C-C
Alternate Detail
(8 Anchor Bolts)

NOTE: See Index No. 17743 and the plans for actual quantity of bolts.

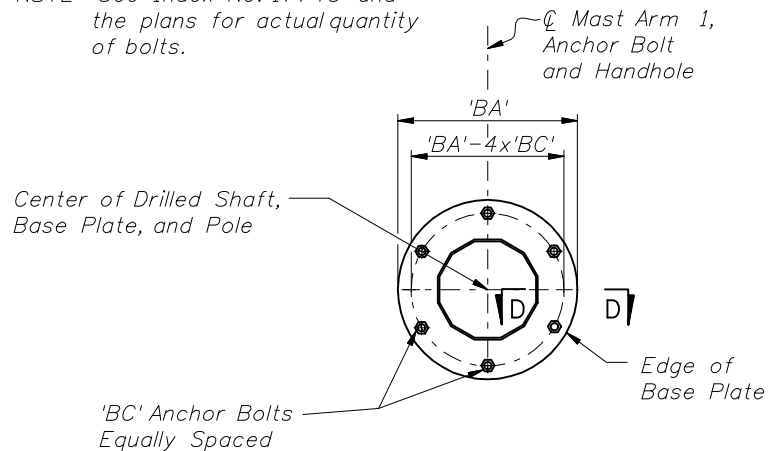

SECTION C-C
(6 Anchor Bolts)

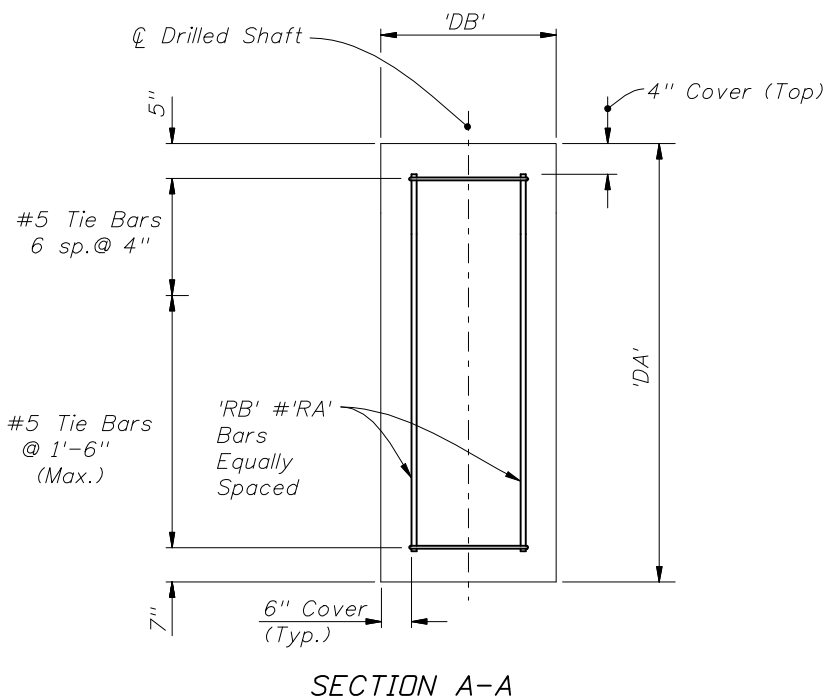

SECTION A-A

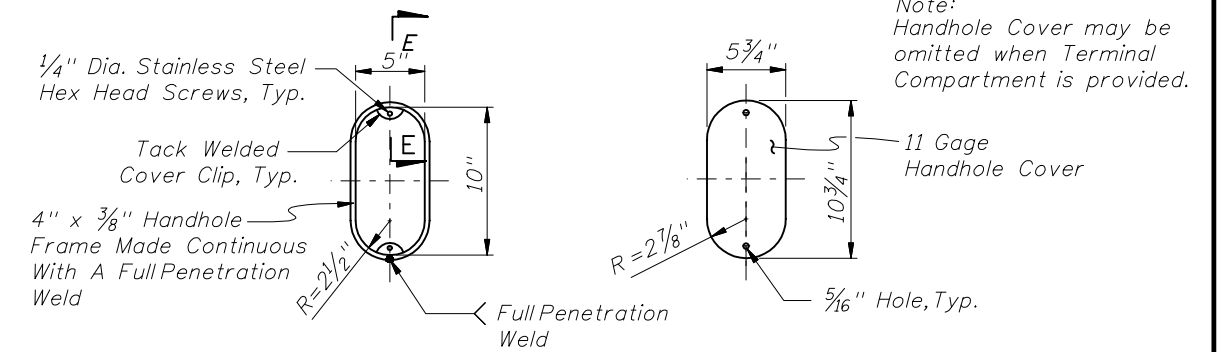

HANDHOLE FRAME
(w/ Terminal Compartment Omitted)

HANDHOLE COVER

Note: Handhole Cover may be omitted when Terminal Compartment is provided.

* Terminal Compartment is optional. See Mast Arm Tabulation for locations.

** Water proof all splices or use gasket with terminal compartment.

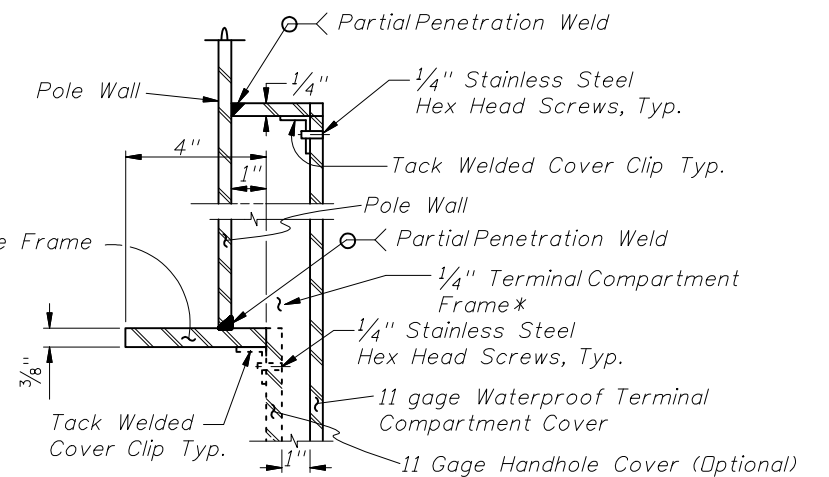

SECTION E-E
(Thru Handhole & Terminal Compartment)

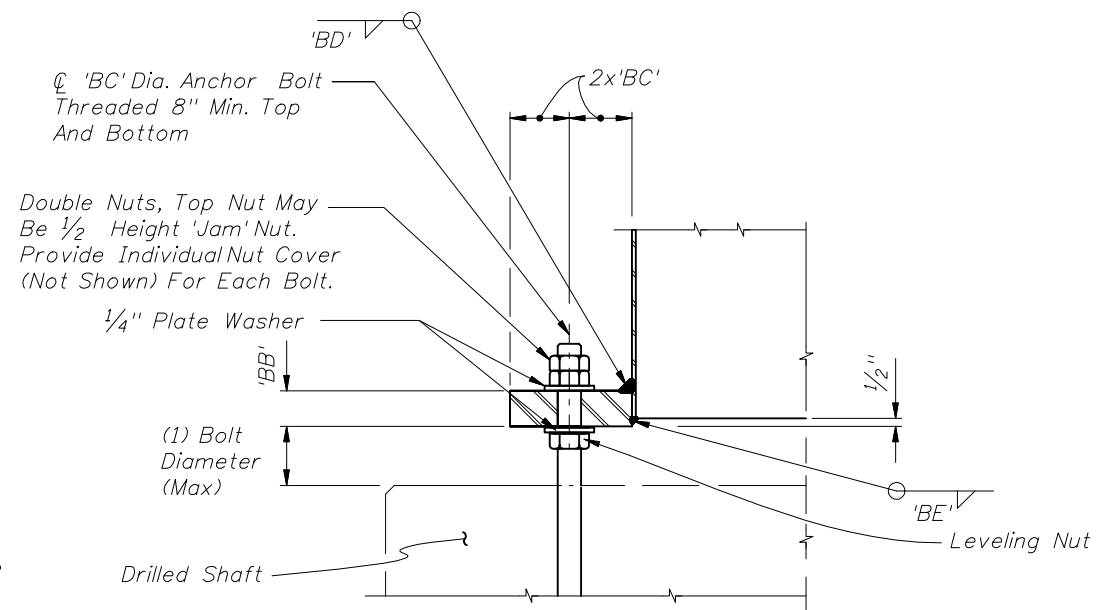

SECTION D-D

TYPICAL FOUNDATION AND BASE PLATE DETAILS



2010 FDOT Design Standards

MAST ARM ASSEMBLIES

Last Revision 07/01/09 Sheet No. 2 of 5

Index No. 17745

The 'Slip Joint' splice shall be a tight fit with no change in the Mast Arm slope due to the splice.

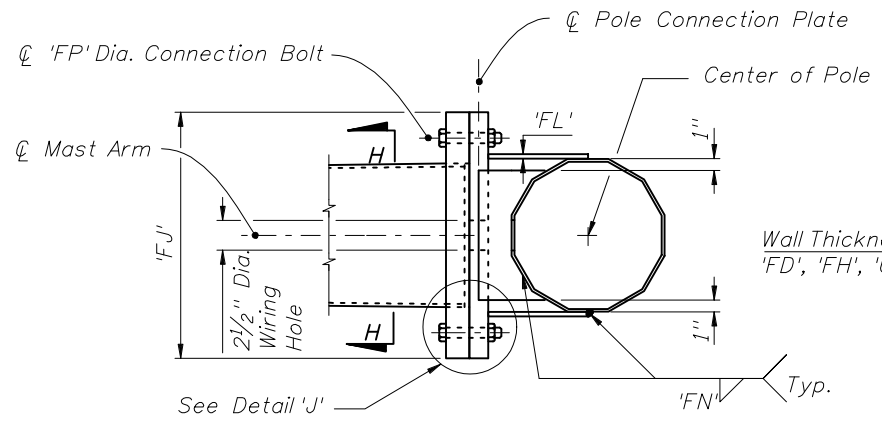

SECTION F-F

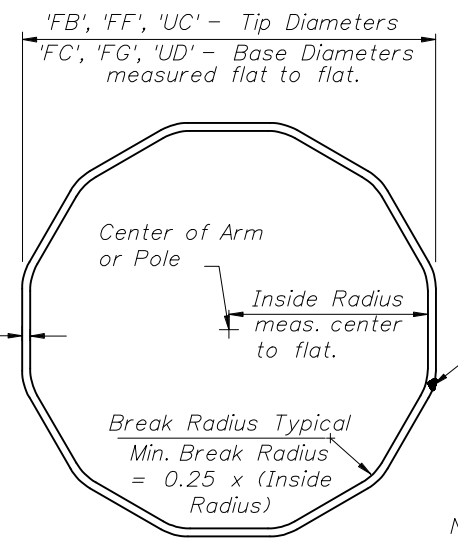

SECTION H-H

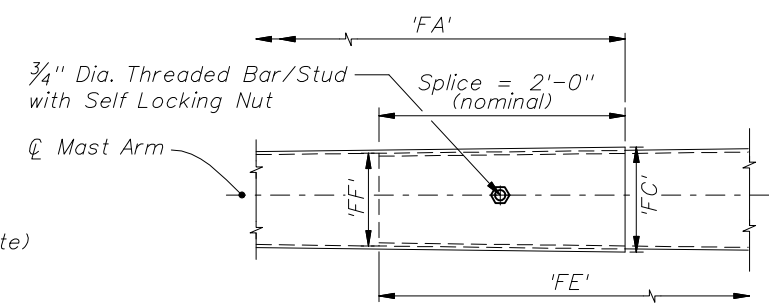

Arm Splice Detail

NOTE: Longitudinal seam welds within six inches of circumferential welds shall be complete penetration welds. Longitudinal seam welds at telescopic field splices shall be complete penetration welds for the splice length plus six inches. For tubes greater than 70" in circumference, two longitudinal seam welds are allowed.

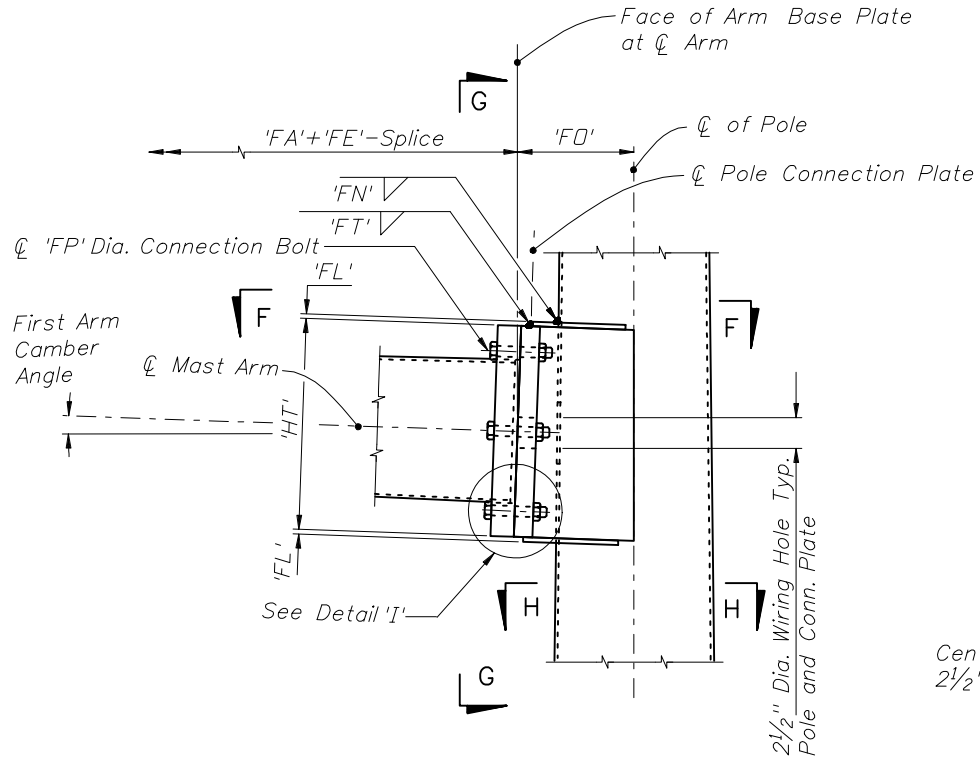

ELEVATION
(Single Arm Connection)

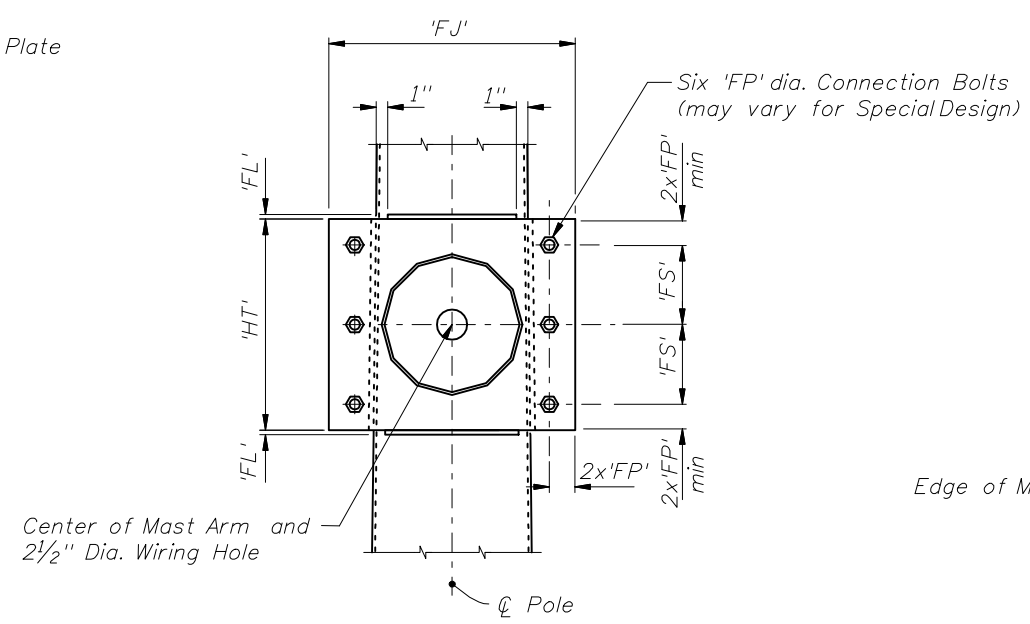

SECTION G-G

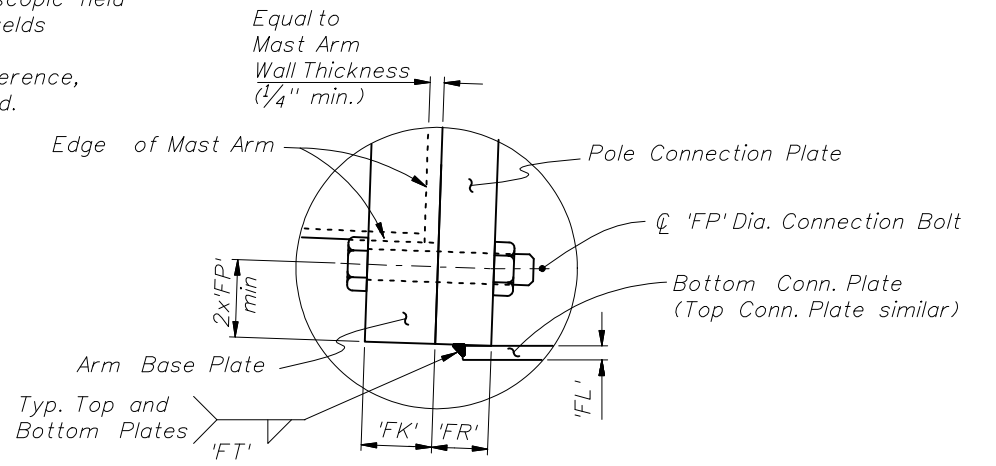

DETAIL 'I'

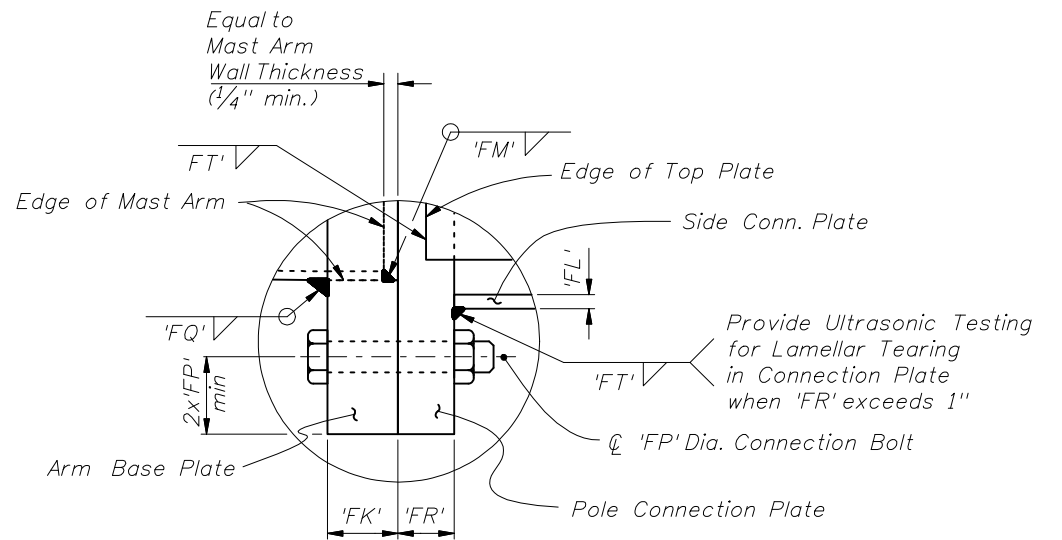

DETAIL 'J'

NOTE:
1. Details shown on this sheet are for 12 sided pole sections. However, sections with more than 12 sides and round sections are permitted provided outside diameter and wall thickness are not reduced.
2. Mast Arm and Connection Plates shall be match marked to ensure proper assembly.

TYPICAL SINGLE ARM CONNECTION DETAILS



2010 FDOT Design Standards

MAST ARM ASSEMBLIES

Last Revision	Sheet No.
07/01/05	3 of 5
Index No.	
17745	

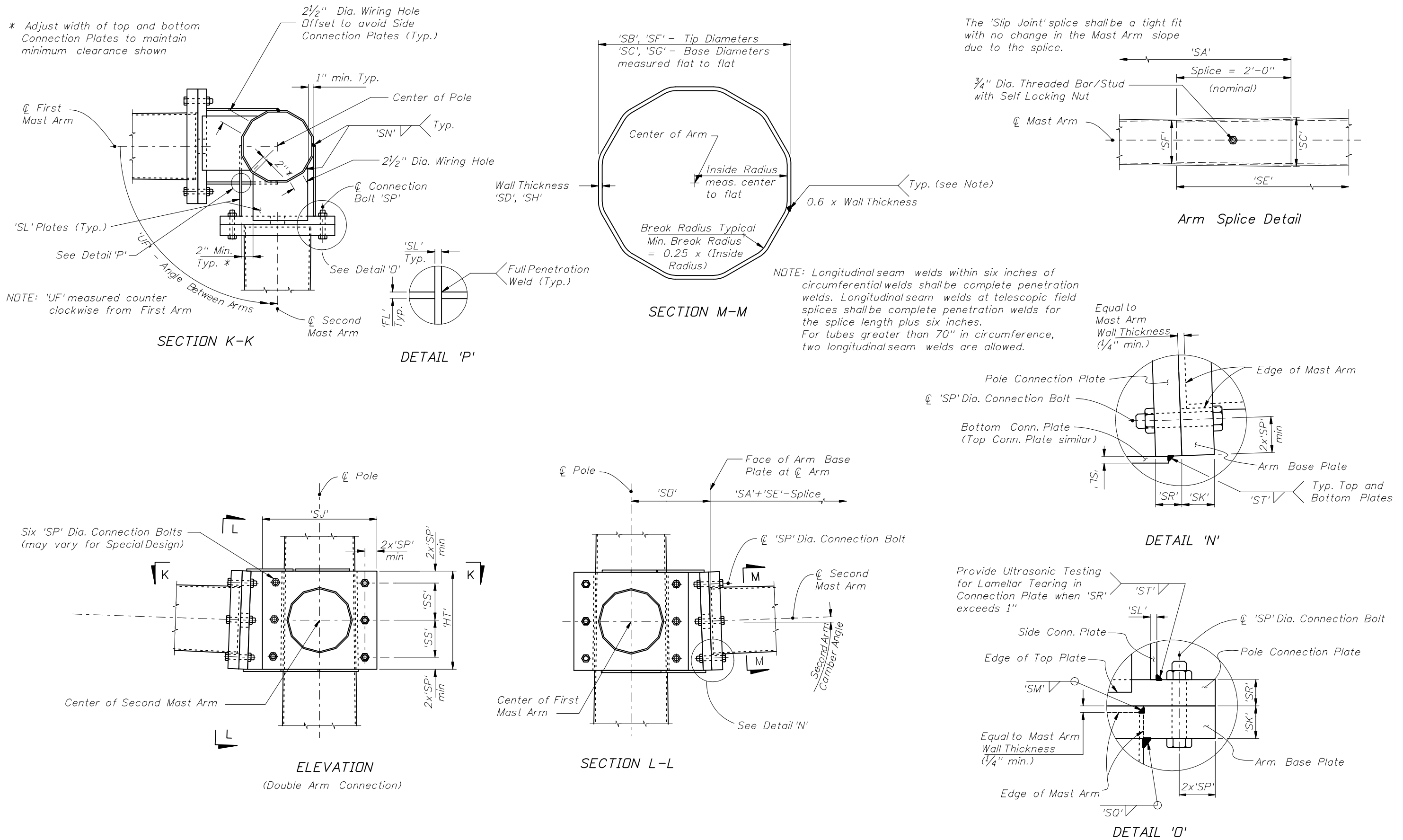

NOTE: Longitudinal seam welds within six inches of circumferential welds shall be complete penetration welds. Longitudinal seam welds at telescopic field splices shall be complete penetration welds for the splice length plus six inches. For tubes greater than 70" in circumference, two longitudinal seam welds are allowed.

NOTE:
 1. Details shown on this sheet are for 12 sided pole sections. However, sections with more than 12 sides and round sections are permitted provided outside diameter and wall thickness are not reduced.
 2. Mast Arm and Connection Plates shall be match marked to ensure proper assembly.

TYPICAL DOUBLE ARM CONNECTION DETAILS

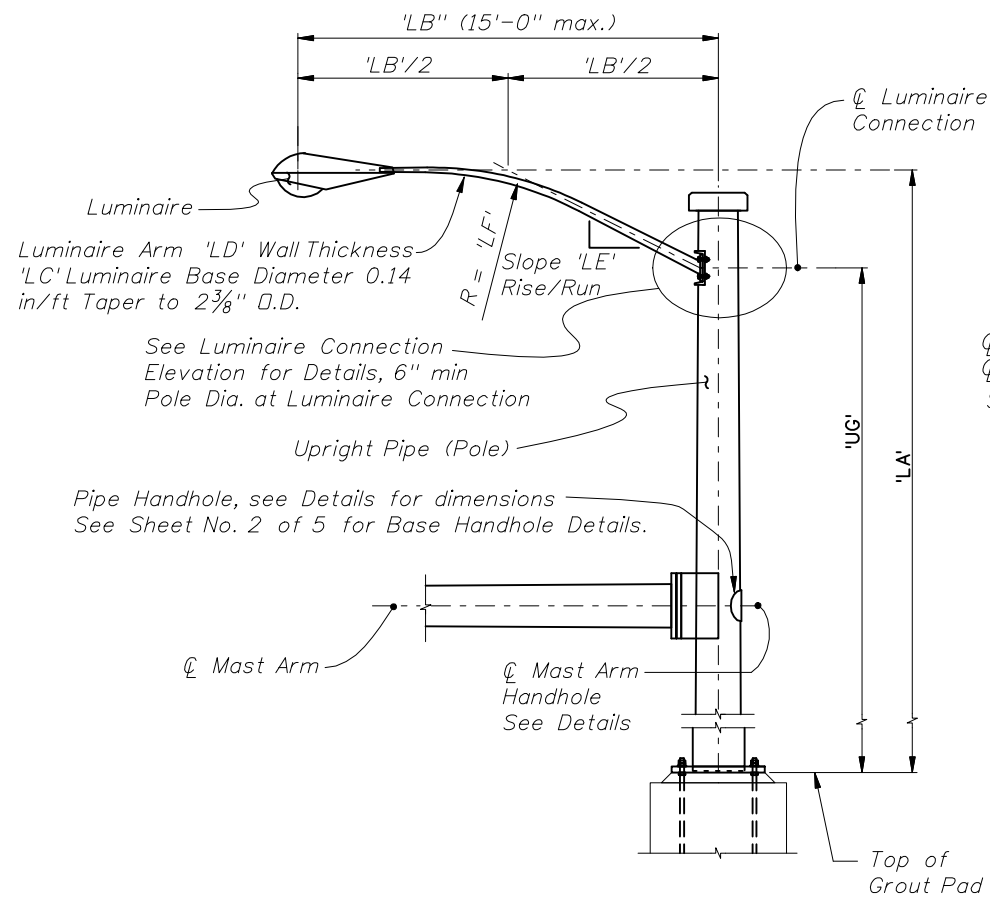

LUMINAIRE ELEVATION

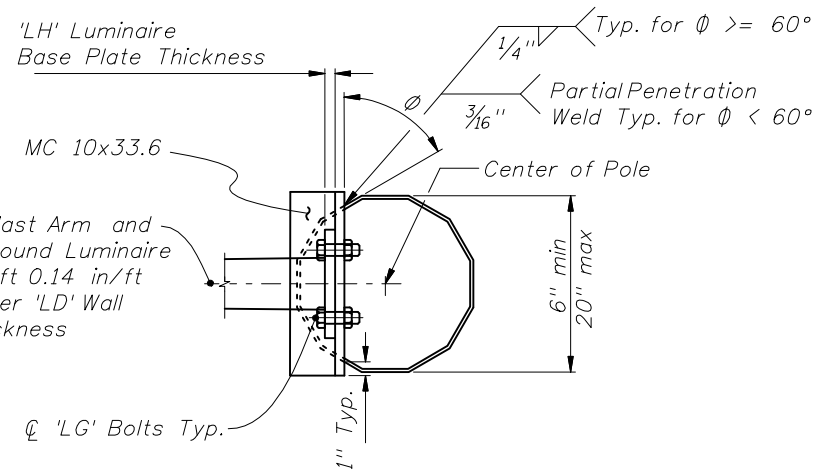

SECTION A-A

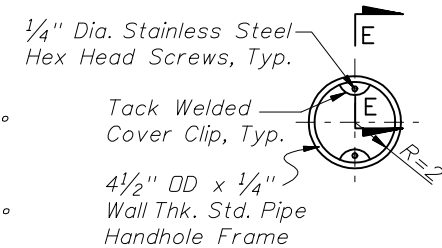

Pipe Handhole Frame

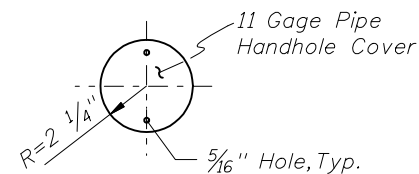

Pipe Handhole Cover

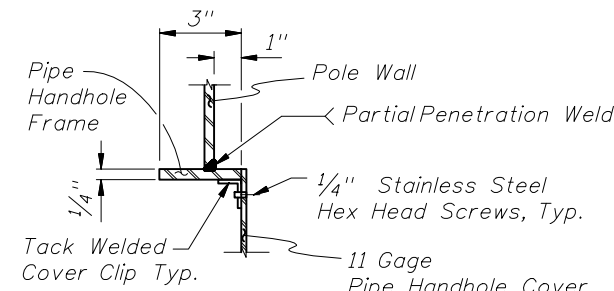

SECTION E-E (thru Pipe Handhole)

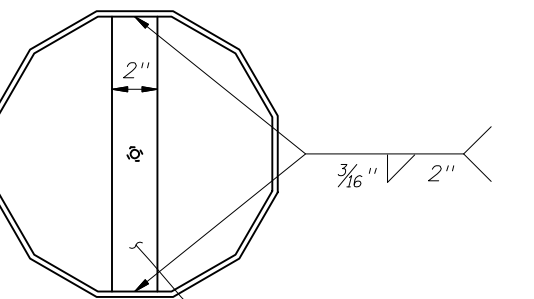
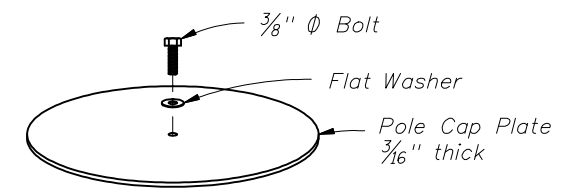

TOP VIEW

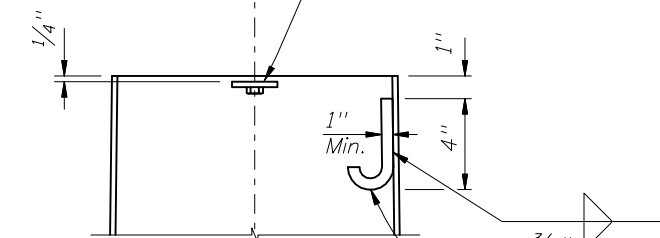

POLE TOP CUT-AWAY (Option 'a')

'J' Hook for wiring, 1/2" Φ commercial grade hot rolled bar welded to inside of pole.

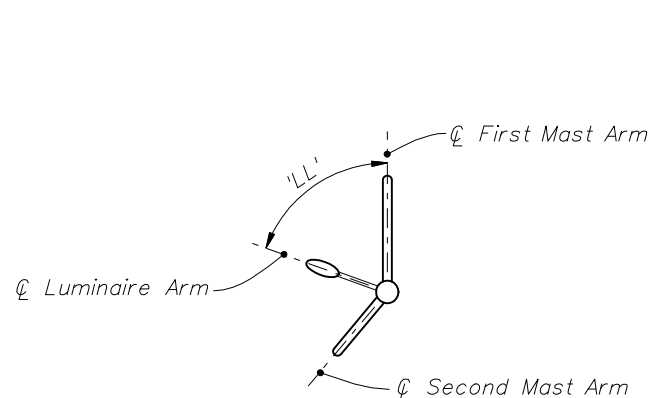

LUMINAIRE ORIENTATION

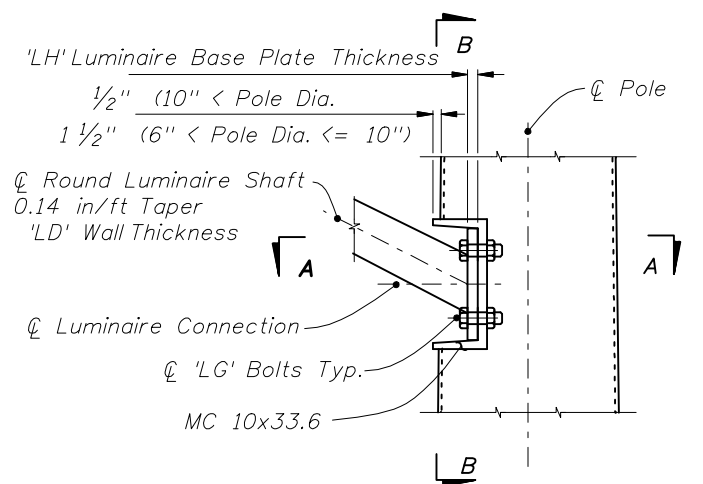

LUMINAIRE CONNECTION ELEVATION

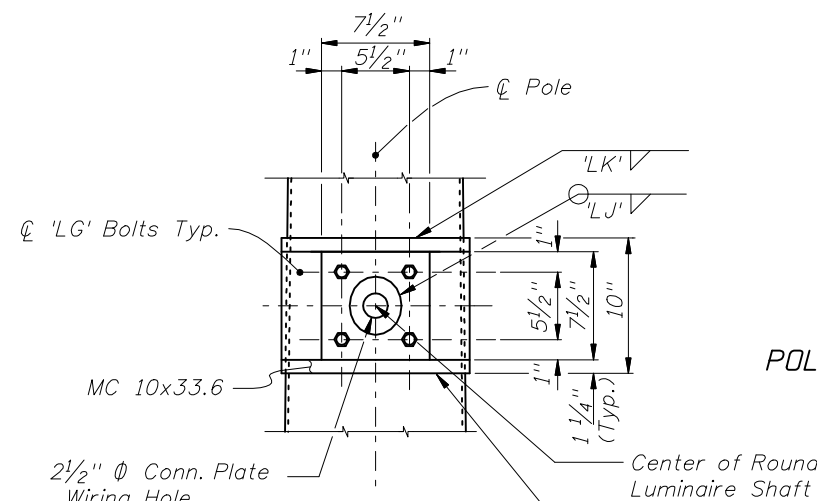

SECTION B-B

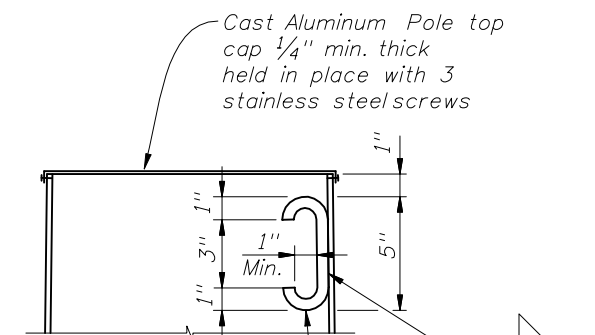

POLE TOP CUT-AWAY (Option 'b')

'C' Hook for wiring and lifting, 1/2" Φ commercial grade hot rolled bar welded to inside of pole.

NOTE: The Pole shown on this sheet is a 12 sided section. However, sections with more than 12 sides and round sections are permitted provided outside diameter and wall thickness are not reduced

NOTE: The Fabricator may substitute a 1/2" thick bent plate with the same flange width, height, and length as the MC 10x33.6 Channel section.

NOTE: Any combination of the above two options may be used, provided both lifting and wiring is accommodated.

NOTES:

1. Luminaire type and Luminaire to Arm Connection Details can be found elsewhere.
2. Align Luminaire Arm with single Mast Arm or first Arm of Double Mast Arm unless indicated otherwise in plans.

TYPICAL LUMINAIRE ARM AND CONNECTION DETAILS

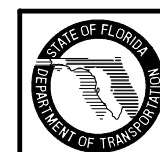

2010 FDOT Design Standards

MAST ARM ASSEMBLIES

Last Revision 07/01/07 Sheet No. 5 of 5

Index No. 17745