

DESIGN STANDARDS

FOR DESIGN, CONSTRUCTION, MAINTENANCE AND UTILITY
OPERATIONS ON THE STATE HIGHWAY SYSTEM

2010

TOPIC NO. 625-010-003

Approved For Use On Federal Aid Projects

J. Chris Ritter

For Martin Knopp, Division Administrator

State of Florida, Department Of Transportation
Roadway Design Office
Mail Station 32
605 Suwannee Street
Tallahassee, Florida 32399-0450

NOTICE

These Design Standards are intended to support the various engineering obligations for designing, constructing, inspecting, maintaining and monitoring the highways, roads and streets on the State Highway System. They are prepared to encourage uniform application of designs and standard details in the preparation of project plans. These Standards may be adopted by other authorities for use on projects under their jurisdiction.

It is the responsibility of the Design Engineer of Record using these Standards to determine the fitness for a particular use of each standard in the design of a project. The inappropriate use of and adherence to these standards does not exempt the engineer from the professional responsibility of developing an appropriate design.

PATENTED DEVICES, MATERIALS AND PROCESSES

The use of any design, method, process, material or device either expressed or implied by these standards that are covered by patent, copyright, or proprietary privilege is the sole responsibility of the user. Any infringement on the rights of the inventor, patentee, assignee or licensee shall be the sole responsibility of the user. For additional information refer to Subsection 7-3 of the FDOT Standard Specifications for Road and Bridge Construction.

Distribution of Exempt Public Documents:

It is the policy of the Department to protect the State Highway System's infrastructure from disclosure under Florida's public records law for documents concerning Department structures. This exemption is created by Section 119.07(3)(ee), F.S. and covered by Department Procedure "Distribution of Exempt Public Documents Concerning Department Structures and Security System Plans (Topic No. 050-020-026)." Structure is defined in Section 334.03(28), F.S., as "a bridge, viaduct, tunnel, causeway, approach, ferry slip, culvert, toll plaza, gate, or other similar facility used in connection with a transportation facility." This includes pipes and pipe systems. Therefore, those portions of Department plans that depict pipes, pipe systems, or the internal layout and structural elements of a structure owned or operated by the Department, are exempt from a public records request under Section 119.07(3)(ee), F.S.. This applies to all formats (paper, electronic, etc.), and at any phase of completion (existing, draft, preliminary, phase reviews, final). Entities or persons outside the Department requesting or receiving copies of any portion of plans considered Exempt Documents will need to complete a request form (Form No. 050-020-26). The form also advises the requestor that the entity or person receiving the information shall maintain the confidential and exempt status of the information. This procedure applies to both Department internal or contracted staff who produce such Exempt Documents in their Department work or have other methods of access to such Exempt Documents in the distribution to persons or entities outside of the Department. Refer to Topic No. 050-020-026 for further requirements.

The pdf version of these standards can be accessed on the following website:

<http://www.dot.state.fl.us/rddesign/DesignStandards/Standards.shtm>

Copies of this document can be procured by contacting the following:

FLORIDA DEPARTMENT OF TRANSPORTATION

MAPS & PUBLICATION SALES

MAIL STATION 12

605 SUWANNEE STREET

TALLAHASSEE, FLORIDA 32399-0450

Phone (850) 414-4050

Fax Number (850) 414-8036

<http://www.dot.state.fl.us/mapsandpublications/>

CERTIFICATION STATEMENT

I hereby certify that this Design Standard Book was compiled under my responsible charge from designs prepared, examined, adopted and implemented by the Florida Department of Transportation in accordance with established procedures, and as approved by the Federal Highway Administration.

*As To Structures
Design Standards Nos.*

199
289-292
302 (Sheets 2-4)
306
403
411
414
420-425
470-490
501,505
521
530
810-880
5100-5301
11200-11860
13417
17502 (Sheets 3-7)
17515
17723,17725
17743,17745
17749
20110-21930

*State Structures Design Engineer
Robert V. Robertson, Jr.
P.E. No. 36160*

Sig: _____

Date:

*As To Roadway
Design Standards Nos.*

001-106
200-288
293,295
300-301
302 (Sheet 1)
303-305
307-310
400-402
410
412
415,417
430
461
500
506-520
525-527
532-540
546,560
600-670
700
800-803
17302-17501
17502 (Sheets 1,2)
17504, 17505
17600,17721
177727-17736
17748
17764-17890

*State Roadway Design Engineer
David C. D'Hagan
P.E. No. 33713*

Sig: _____

Date:

*As To Planning
Design Standard No.
17900*

*Manager, Traffic Data Section
Transportation Statistics Office
Richard L. Reel, Jr.
P.E. No. 22400*

Sig: _____

Date:

*As To ITS
Design Standard Nos.
18100-18305*

*Deputy State Traffic
Operations Engineer
Mark C. Wilson
P.E. No. 46780*

Sig: _____

Date:

*As To Landscape
Architecture
Design Standard No.
544*

*State Transportation
Landscape Architect
Jeff H. Caster
LA0001592*

Sig: _____

Date:

THIS SHEET INTENDED TO BE BLANK

TABLE OF CONTENTS

REVISIONS

Revisions Sheets Since Publication Of The 2008 Booklet (5 Sheets)

ABBREVIATIONS AND SYMBOLS

001 Standard Abbreviations (3 Sheets)
002 Standard Symbols (3 Sheets)

EROSION CONTROL AND WATER QUALITY

100 Temporary Slope Drain And Sod Flume
101 Trash Retainer And Sediment Basin
102 Temporary Erosion And Sediment Control (3 Sheets)
103 Turbidity Barriers
104 Permanent Erosion Control (2 Sheets)
105 Shoulder Sodding And Turf On Existing Facilities
106 Soil Tracking Prevention Device Type A

DRAINAGE

199 Geotextile Criteria
200 Structure Bottoms—Type J And P (5 Sheets)
201 Supplementary Details For Manholes And Inlets (5 Sheets)
205 Cover Height (6 Sheets)
206 Trench Drain (2 Sheets)
210 Curb Inlet Tops—Types 1, 2, 3 And 4
211 Curb Inlet Tops—Types 5 and 6 (5 Sheets)
212 Curb Inlet—Type 7
213 Curb Inlet—Type 8
214 Curb Inlet Top—Type 9
215 Curb Inlet Top—Type 10
216 Closed Flume Inlet (3 Sheets)
217 Median Barrier Inlets Types 1, 2, 3, 4 And 5 (2 Sheets)
218 Barrier Wall Inlet (2 Sheets)
219 Barrier Wall Inlet—Barrier Wall, Concrete (Rigid) (C & G) (2 Sheets)
220 Gutter Inlet—Type S (3 Sheets)
221 Gutter Inlet—Type V (2 Sheets)
230 Ditch Bottom Inlet—Type A (2 Sheets)
231 Ditch Bottom Inlet—Type B (3 Sheets)
232 Ditch Bottom Inlets—Types C, D, E And H (7 Sheets)
233 Ditch Bottom Inlets—Types F And G (2 Sheets)
234 Ditch Bottom Inlet—Type J (2 Sheets)
235 Ditch Bottom Inlet—Type K (2 Sheets)
240 Skimmer For Outlet Control Structures (2 Sheets)
241 Skimmers For French—Drain Outlets
245 Underdrain Inspection Box
250 Straight Concrete Endwalls—Single And Multiple Pipe (2 Sheets)
251 Straight Concrete Endwalls—Single And Double 60" Pipe (2 Sheets)
252 Straight Concrete Endwalls—Single And Double 66" Pipe (2 Sheets)
253 Straight Concrete Endwalls—Single And Double 72" Pipe (2 Sheets)
255 Straight Concrete Endwall—Single 84" Pipe
258 Straight Sand—Cement Endwalls
260 U—Type Concrete Endwalls With Grates—15" To 30" Pipe
261 U—Type Concrete Endwalls—Baffles And Grate Optional—15" To 30" Pipe (3 Sheets)

DRAINAGE (CONT.)

264 U—Type Concrete Endwall—Energy Dissipator—30" To 72" Pipe (2 Sheets)
266 Winged Concrete Endwalls—Single Round Pipe
268 U—Type Sand—Cement Endwalls
270 Flared End Section
272 Cross Drain Mitered End Section (6 Sheets)
273 Side Drain Mitered End Section (7 Sheets)
280 Miscellaneous Drainage Details (3 Sheets)
281 Ditch Pavement And Sodding (2 Sheets)
282 Back Of Sidewalk Drainage (3 Sheets)
283 Median Opening Flume
284 Concrete Shoulder Gutter Spillway
285 French Drain (2 Sheets)
286 Underdrain (2 Sheets)
287 Concrete Pavement Subdrainage (4 Sheets)
288 Deep Well Injection Box
289 Concrete Box Culvert Details (LRFD) (7 Sheets)
291 Supplemental Details For Precast Concrete Box Culverts (5 Sheets)
292 Standard Precast Concrete Box Culverts (14 Sheets)
293 Safety Modifications For Inlets In Box Culverts
295 Safety Modifications For Endwalls

CURBS AND PAVEMENT JOINTS

300 Curb & Curb And Gutter (2 Sheets)
301 Turn Lanes
302 Traffic Separators (4 Sheets)
303 Curb Return Profiles
304 Public Sidewalk Curb Ramps (6 Sheets)
305 Concrete Pavement Joints (4 Sheets)
306 Bridge Approach Expansion Joint—Concrete Pavement
307 Miscellaneous Utility Details (3 Sheets)
308 Concrete Slab Replacement (2 Sheets)
310 Concrete Sidewalk (2 Sheets)

TRAFFIC RAILINGS

400 Guardrail (26 Sheets)
402 Guardrail Transitions And Connections For Existing Bridges (24 Sheets)
403 Guardrail Transitions For Existing Bridge Traffic Railing Retrofits (3 Sheets)
410 Concrete Barrier Wall (25 Sheets)
411 Pier Protection Barrier (10 Sheets)
412 Low Profile Barrier (5 Sheets)
414 Type K Temporary Concrete Barrier (15 Sheets)
415 Temporary Concrete Barrier (10 Sheets)
417 Inertial Crash Cushion
420 Traffic Railing — (32" F Shape) (3 Sheets)
421 Traffic Railing — (Median 32" F Shape) (3 Sheets)
422 Traffic Railing — (42" Vertical Shape) (3 Sheets)
423 Traffic Railing — (32" Vertical Shape) (3 Sheets)
424 Traffic Railing — (Corral Shape) (7 Sheets)
425 Traffic Railing — (42" F Shape) (3 Sheets)
430 Optional Crash Cushion Details (2 Sheets)
461 Opaque Visual Barrier

TRAFFIC RAILINGS (CONT.)

470 Traffic Railing — (Thrie Beam Retrofit) General Notes & Details (3 Sheets)
471 Traffic Railing — (Thrie Beam Retrofit) Narrow Curb (4 Sheets)
472 Traffic Railing — (Thrie Beam Retrofit) Wide Strong Curb Type 1 (4 Sheets)
473
474 Traffic Railing — (Thrie Beam Retrofit) Intermediate Curb (4 Sheets)
475 Traffic Railing — (Thrie Beam Retrofit) Wide Curb Type 1 (4 Sheets)
476 Traffic Railing — (Thrie Beam Retrofit) Wide Curb Type 2 (4 Sheets)
480 Traffic Railing — (Vertical Face Retrofit) General Notes & Details (2 Sheets)
481 Traffic Railing — (Vertical Face Retrofit) Narrow Curb (3 Sheets)
482 Traffic Railing — (Vertical Face Retrofit) Wide Curb (4 Sheets)
483 Traffic Railing — (Vertical Face Retrofit) Intermediate Curb (3 Sheets)
490

GENERAL

500 Removal Of Organic And Plastic Material (2 Sheets)
501 Geosynthetic Reinforced Soils (9 Sheets)
505 Embankment Utilization (4 Sheets)
506 Miscellaneous Earthwork Details
510 Superelevation—Rural Highways, Urban Freeways And High Speed Urban Highways (2 Sheets)
511 Superelevation—Urban Highways And Streets (3 Sheets)
514 Optional Base Group And Structural Numbers (2 Sheets)
515 Turnouts (7 Sheets)
516 Turnouts—Resurfacing Projects
518 Rumble Strips (3 Sheets)
520 Gravity Wall
521 Concrete Steps
525 Ramp Terminals (5 Sheets)
526 Roadway Transitions (8 Sheets)
527 Directional Median Opening (3 Sheets)
530 Rest Area Equipment (3 Sheets)
532 Mailboxes (3 Sheets)
535 Tractor Crossings
540 Settlement Plate
544 Landscape Installation (3 Sheets)
546 Sight Distance At Intersections (6 Sheets)
560 Railroad Crossings

TRAFFIC CONTROL THROUGH WORK ZONES

600 General Information For Traffic Control Through Work Zones (13 Sheets)
601 Two-Lane Two-Way, Work Outside Shoulder
602 Two-Lane Two-Way, Work On Shoulder
603 Two-Lane Two-Way, Work Within The Travel Way (2 Sheets)
604 Two-Lane Two-Way, Work In Intersection
605 Two-Lane Two-Way, Work Near Intersection
606 Two-Lane Two-Way, Work Within The Travel Way—Signal Control (4 Sheets)
607 Two-Lane Two-Way, Mobile Operation, Work On Shoulder And Work Within The Travel Way
608 Two-Lane Two-Way, Temporary Diversion Connection
611 Multilane, Work Outside Shoulder
612 Multilane, Work On Shoulder
613 Multilane, Work Within The Travel Way—Median Or Outside Lane (2 Sheets)
614 Multilane, Work Within The Travel Way—Center Lane (2 Sheets)
615 Multilane, Work In Intersection

TABLE OF CONTENTS

TRAFFIC CONTROL THROUGH WORK ZONES (CONT.)

616	Multilane, Work Near Intersection-Median Or Outside Lane (3 Sheets)
617	Multilane, Work In Intersection-Center Lane
618	Multilane, Work In Intersection-Two Lanes Closed-45 MPH Or Less
619	Multilane, Mobile Operations Work On Shoulder, Work Within Travel Way
620	Multilane Divided, Temporary Diversion Connection (2 Sheets)
621	Multilane Undivided, Temporary Diversion Connection
622	Multilane, Work Near Intersection-Temporary Diversion Connection -35 MPH or Less
625	Temporary Road Closure-5 Minutes Or Less
628	Two Way Left Turn Lane Closure
630	Crossover For Paving Train Operations, Rural (2 Sheets)
631	Temporary Crossover (2 Sheets)
635	Work In Vicinity Of Railroad Crossing
640	Converting Two-Lanes To Four-Lanes Divided, Rural (2 Sheets)
641	Converting Two-Lanes To Four-Lanes Divided, Urban (3 Sheets)
642	Transitions For Temporary Concrete Barrier Wall On Freeway Facilities
650	Two-Lane Two-Way, Rural Structure Replacement (2 Sheets)
651	Multilane Divided, Maintenance And Construction (2 Sheets)
655	Traffic Pacing (3 Sheets)
660	Pedestrian Control For Closure Of Sidewalks
665	Limited Access, Temporary Opening
667	Toll Plaza, Traffic Control Standards (6 Sheets)
670	Motorist Awareness System

ROADSIDE OFFSETS

700	Roadside Offsets (2 Sheets)
-----	-----------------------------

FENCING AND PEDESTRIAN RAILINGS

800	Fence Location (2 Sheets)
801	Fence-Type A (3 Sheets)
802	Fence-Type B (3 Sheets)
803	Cantilever Slide Gate-Type B Fence
810	Bridge Fencing (Vertical) (4 Sheets)
811	Bridge Fencing (Curved Top) (3 Sheets)
812	Bridge Fencing (Enclosed) (4 Sheets)
820	Pedestrian/Bicycle Railing
821	Aluminum Pedestrian/Bicycle Bullet Railing For Traffic Railing (32" F Shape)
822	Aluminum Pedestrian/Bicycle Bullet Railing Details (2 Sheets)
850	Steel Pedestrian/Bicycle Picket Railing (5 Sheets)
851	Bridge Pedestrian/Bicycle Picket Railing (Steel) (2 Sheets)
860	Aluminum Pedestrian/Bicycle Picket Railing (5 Sheets)
861	Bridge Pedestrian/Bicycle Picket Railing (Aluminum) (2 Sheets)
870	Aluminum Pipe Guiderail (5 Sheets)
880	Steel Pipe Guiderail (5 Sheets)

WALL AND SOUND BARRIER SYSTEMS

5100	Retaining Wall-Cast In Place (2 Sheets)
5200	Precast Sound Barriers-General Notes
5201	Precast Sound Barriers-Texture Options
5202	Precast Sound Barriers-Flush Panel Option (4 Sheets)
5203	Precast Sound Barriers-Recessed Panel Option (5 Sheets)
5204	Precast Sound Barriers-Fire Hose Access Hole & Drainage Details
5205	Precast Sound Barriers-Pile and Post Reinforcing Steel (7 Sheets)
5206	Precast Sound Barriers-Pile Depth and Reinforcing Summary
5207	Precast Sound Barriers-Precast Post Capital
5210	Traffic Railing/Sound Barrier (8'-0") (5 Sheets)
5211	Traffic Railing/Sound Barrier (14'-0") (3 Sheets)
5212	Traffic Railing/Sound Barrier (8'-0") Junction Slab (2 Sheets)
5213	Traffic Railing/Sound Barrier T-Shape Spread Footing (2 Sheets)
5214	Traffic Railing/Sound Barrier L-Shaped Spread Footing (4 Sheets)
5215	Traffic Railing/Sound Barrier Trench Footing
5300	Permanent Retaining Wall Systems (19 Sheets)
5301	Temporary Retaining Wall Systems

SIGNING AND MARKINGS

11200	Multi-Column Ground Sign (2 Sheets)
11300	Steel Overhead Sign Structures
11310	Cantilever Sign Structure (5 Sheets)
11320	Span Sign Structure (5 Sheets)
11860	Single Column Ground Signs (8 Sheets)
13417	Mounting Exit Numbering Panels To Highway Signs
17302	Typical Sections For Placement Of Single & Multi-Column Signs
17328	Typical Signing For Truck Weigh & Inspection Stations (2 Sheets)
17344	School Signs & Markings (6 Sheets)
17345	Interchange Markings (4 Sheets)
17346	Special Marking Areas (14 Sheets)
17347	Bicycle Markings (4 Sheets)
17349	Traffic Controls For Street Terminations
17350	Signing For Motorist Services
17351	Welcome Center Signing (2 Sheets)
17352	Typical Placement Of Reflective Pavement Markers (2 Sheets)
17355	Special Sign Details (11 Sheets)
17356	Span Wire Mounted Sign Details
17357	Bridge Weight Restrictions
17359	Rural Narrow Bridge Treatment (2 Sheets)

ROADWAY LIGHTING

17500	Conventional Lighting (3 Sheets)
17501	Highway Lighting General Notes
17502	Highmast Lighting (7 Sheets)
17504	Service Point Details
17505	External Lighting For Signs (2 Sheets)
17515	Standard Roadway Aluminum Lighting (8 Sheets)

TRAFFIC SIGNAL AND EQUIPMENT

17600	Motorist Aid Call Box (3 Sheets)
17721	Conduit Installation Details (2 Sheets)
17723	Steel Strain Pole (3 Sheets)
17725	Concrete Poles (2 Sheets)
17727	Signal Cable And Span Wire Installation Details (2 Sheets)
17733	Aerial Interconnect
17736	Electric Power Service
17743	Standard Mast Arm Assemblies (3 Sheets)
17745	Mast Arm Assemblies (5 Sheets)
17748	Free-Swinging, Internally-Illuminated Street Sign Assemblies
17749	Damping Device For Miscellaneous Structures
17764	Pedestrian Control Signal Installation Details
17781	Vehicle Loop Installation Details (2 Sheets)
17784	Pedestrian Detector Assembly Installation Details (2 Sheets)
17841	Cabinet Installation Details
17870	Standard Signal Operating Plans (2 Sheets)
17881	Advance Warning For R/R Crossing
17882	Railroad Grade Crossing Traffic Control Devices (4 Sheets)
17890	Traffic Control Devices For Movable Span Bridge Signals (3 Sheets)

MISCELLANEOUS

17900	Traffic Monitoring Site (7 Sheets)
-------	------------------------------------

ITS

18100	CCTV Pole Placement
18101	Typical CCTV Site
18102	CCTV Pole Grounding (2 Sheets)
18104	CCTV Cabinet Equipment Layout
18105	CCTV Block Diagram
18107	Ground Mounted CCTV Cabinet
18108	Pole Mounted CCTV Cabinet
18110	Camera Mounting Details (2 Sheets)
18111	Steel CCTV Pole (2 Sheets)
18113	Concrete CCTV Pole (2 Sheets)
18202	Fiber Optic Pullbox And Trench Details
18204	Fiber Optic Splice Box And Pullbox
18300	DMS Cabinet And Sign Wiring And Block Diagram
18301	DMS Cabinet Layout
18302	Typical DMS Mounting Details
18303	DMS Structures Details (2 Sheets)
18305	DMS Grounding Details (2 Sheets)

TABLE OF CONTENTS

PRESTRESSED CONCRETE AASHTO BEAMS

- 20110 Typical AASHTO And Bulb-T Beam Details and Notes
- 20120 AASHTO Type II-Beam Standard Details
- 20130 AASHTO Type III Beam - Standard Details
- 20140 AASHTO Type IV Beam - Standard Details
- 20150 AASHTO Type V Beam - Standard Details
- 20160 AASHTO Type VI Beam - Standard Details
- 20172 Florida Bulb-T 72 Beam - Standard Details
- 20178 Florida Bulb-T 78 Beam - Standard Details
- 20199 Build-Up And Deflection Data For AASHTO And Bulb-T Beams

PRESTRESSED CONCRETE FLORIDA U BEAMS (FUB)

- 20210 Typical Florida U Beam Details And Notes (2 Sheets)
- 20248 Florida U 48 Beam - Standard Details (3 Sheets)
- 20254 Florida U 54 Beam - Standard Details (3 Sheets)
- 20263 Florida U 63 Beam - Standard Details (3 Sheets)
- 20272 Florida U 72 Beam - Standard Details (3 Sheets)
- 20299 Build-Up And Deflection Data For Florida U Beams

PRESTRESSED CONCRETE INVERTED-T BEAMS

- 20310 Typical Inverted-T Beam Details And Notes
- 20320 Inverted-T Beam Standard Details

CONCRETE SHEET PILES

- 20400 Notes And Details For Precast Concrete Sheet Piles
- 20410 Precast Concrete Sheet Pile Type "A" - 10 Inch Thick
- 20412 Precast Concrete Sheet Pile Type "A" - 12 Inch Thick
- 20430 Precast Concrete Sheet Pile Type "B" - Variable Angle Corner Pile
- 20440 Precast Concrete Sheet Pile Type "C" - Right Angle Corner Pile

BEARING PADS

- 20500 Composite Elastomeric Bearing Pads
- 20501 Beveled Bearing Plate Details-Prestressed AASHTO And Bulb-T Beams
- 20502 Beveled Bearing Plate Details-Florida U-Beams

SQUARE AND ROUND CONCRETE PILES

- 20600 Notes And Details For Square Prestressed Concrete Piles
- 20601 Square Prestressed Concrete Pile Splices
- 20602 EDC Instrumentation For Square Prestressed Concrete Piles
- 20612 12" Square Prestressed Concrete Pile
- 20614 14" Square Prestressed Concrete Pile
- 20618 18" Square Prestressed Concrete Pile
- 20620 20" Square Prestressed Concrete Pile
- 20624 24" Square Prestressed Concrete Pile
- 20630 30" Square Prestressed Concrete Pile
- 20631 High Moment Capacity 30" Square Prestressed Concrete Pile
- 20654 54" Precast/Post-Tensioned Concrete Cylinder Pile (2 Sheets)
- 20660 60" Prestressed Concrete Cylinder Pile (2 Sheets)

APPROACH SLABS

- 20900 Approach Slabs (Flexible Pavement Approaches) (2 Sheets)
- 20910 Approach Slabs (Rigid Pavement Approaches) (2 Sheets)

BRIDGE EXPANSION JOINTS

- 21100 Strip Seal Expansion Joint (3 Sheets)
- 21110 Poured joint With Backer Rod Expansion Joint System (2 Sheets)

STRUCTURES LIGHTING AND UTILITIES

- 21200 Light Pole Pilaster (2 Sheets)
- 21210 Utility Conduit Details (2 Sheets)
- 21220 Navigation Light System Details (Fixed Bridges) (2 Sheets)
- 21240 Maintenance Lighting For Box Girders (2 Sheets)

STANDARD BAR BENDING DETAILS

- 21300 Standard Bar Bending Details

TEMPORARY DETOUR BRIDGES

- 21600 Temporary Detour Bridge General Notes And Details (7 Sheets)
- 21610 Temporary Detour Bridge Details-Timber Pile Foundations (3 Sheets)
- 21620 Temporary Detour Bridge Details-Steel H Pile Foundations (2 Sheets)
- 21630 Temporary Detour Bridge Details-Steel Pipe Pile Foundations (3 Sheets)

POST-TENSIONING DETAILS

- 21801 Post-Tensioning Vertical Profiles (2 Sheets)
- 21802 Post-Tensioning Anchorage Protection
- 21803 Post-Tensioning Anchorage And Grouting Details (3 Sheets)

FENDER SYSTEMS DETAILS

- 21900 Fender System General Notes And Layout (2 Sheets)
- 21910 Fender System Heavy Duty (5 Sheets)
- 21920 Fender System Medium Duty (5 Sheets)
- 21930 Fender System Light Duty (5 Sheets)

**Revisions
Design Standards 2010**

Index Number	Sheet Number	Description	Index Number	Sheet Number	Description
001	1 thru 3	Added the following standard abbreviations: B Base Line, Base Line Control FL Flow Line GRI Geosynthetic Research Institute HDPE High Density Polyethylene NPS Nominal Pipe Size Deleted the following standard abbreviations: Bbl Barrel FRCP Fiber Reinforced Concrete Pipe FRP Fiber Reinforced Pipe FS Far Side	233	1 thru 2	Index was expanded due to font size change.
			234	1 thru 2	Index was expanded due to font size change.
				2 of 2	Under Pavement & Sodding detail changed "1/2" Exp. Joint" to "1/2" Preformed Joint Filler".
			235	1 of 2	"GENERAL NOTES", Note 3, deleted "Alternate B" replaced with "Index 200"; Note 8 changed "Specification Section 962" to "Specification Section 975".
			245	1 of 1	"GENERAL NOTES" Note 2, delete and replace with the following: "Concrete shall be Class I (Structural), except ASTM C478 (4000 psi) concrete may be substituted for precast items manufactured in plants meeting the requirements of Section 449 of the Specifications. Box shall be reinforced with No. 3 bars (Grade 60) on 8" centers both ways, sides and bottom.
002	2 of 3	Deleted Hand Drafting Symbols	250	1 of 2	"GENERAL NOTES" Note 5, deleted and replaced with the following: "Concrete shall be Class I (Structural), except ASTM C478 (4000 psi) concrete may be substituted for precast items manufactured in plants meeting the requirements of Section 449 of the Specifications."
102	2 of 3	NOTES FOR SYNTHETIC BALES OR BALE TYPE BARRIERS, Note 2, deleted the text "trenched 3" to 4" and" from the first sentence.	251	1 of 2	"GENERAL NOTES" Note 4, deleted and replaced with the following: "Concrete shall be Class II, except ASTM C478 (4000 psi) concrete may be substituted for precast items manufactured in plants meeting the requirements of Section 449 of the Specifications."
104	2 of 2	RURAL DIVIDED detail, changed "5' Shoulder Pavement" to "4' Shoulder Pavement".	252	1 of 2	"GENERAL NOTES" Note 4, deleted and replaced with the following: "Concrete shall be Class II, except ASTM C478 (4000 psi) concrete may be substituted for precast items manufactured in plants meeting the requirements of Section 449 of the Specifications."
105	1 of 1	TREATMENT I, Criteria for using Treatment I, replaced text of the last bullet with the following: "resurfacing build-up is less than 3" "	253	1 of 2	"GENERAL NOTES" Note 4, deleted and replaced with the following: "Concrete shall be Class II, except ASTM C478 (4000 psi) concrete may be substituted for precast items manufactured in plants meeting the requirements of Section 449 of the Specifications."
200	1 of 5	TOP SLAB REINFORCING STEEL DIAGRAM (ALTERNATE B) to the notes "2 Additional Bars A @ 5" O.C." and "2 Additional Bars B @ 5" Max. O.C. Each Side Of Opening", added "(Minimum #4 Bars)".	255	1 of 2	"GENERAL NOTES" Note 4, deleted and replaced with the following: "Concrete shall be Class II, except ASTM C478 (4000 psi) concrete may be substituted for precast items manufactured in plants meeting the requirements of Section 449 of the Specifications."
	2 of 5	Note 9, Delete second sentence and substitute, "Additional bars used to restrain hole formers for precast structures with grouted pipe connections, may be left flush with the hole surface."	260	1 of 1	"GENERAL NOTES" Note 3 changed "Specification Section 962" to "Specification Section 975".
	4 of 5	SLAB AND WALL DESIGN TABLE NOTES, added the following to the end of Note 10: "See Index No. 201, Sheet 4 for allowable bar spacing adjustments when larger areas of reinforcing are substituted."	261	1 of 3	"GENERAL NOTES" Note 4 changed "Specification Section 962" to "Specification Section 975".
201	4 of 5	"Revised title of notes to ""NOTES FOR PRECAST OPTIONS AND EQUIVALENT REINFORCEMENT SUBSTITUTION"" and added the following to Note 4, ""When an increased area of reinforcing is provided, then the maximum bar spacing may be increased by the squared ratio of increased steel area, but not to exceed 12 inches: Max. Bar Spacing Provided < Max. Bar Spacing Required x (Steel Area Provided/Min. Steel Area Required) ² "	264	1 thru 2	Index was expanded due to font size change. General note 3 changed.
205	1 of 6	Changed maximum size of allowed PVC pipe to 36".	270	1 of 1	"GENERAL NOTES" Note 2 changed "Specification Section 941-1.5" to "Specification Section 449". Changed Note 3.
	2 of 6	ROUND PIPE DIMENSIONS, deleted the column, "Wall Thickness (In.) Class III" and subcolumn "NRCHP" and heading "SRCP". Also deleted the ** note at the bottom of the table.	272	6 of 6	Reordered "GENERAL NOTES" and changed "Class I concrete" to "Class NS concrete".
	3 of 6	NOTES: deleted note 4; table "PIPE ARCH: SPIRAL RIB: 3/4" x 3/4" x 7 1/2" RIB SPACING..." deleted references to note 4; table "ROUND PIPE - SPIRAL RIB", "Maximum Height of Fill (Ft.)", "Sheet Thickness In Inches (Gage)", "0.138 (10)" added measurements.	273	1 thru 7	Index was expanded due to font size change.
210	1 of 1	Delete General Note 4, and substitute the following: "For precast units the rear wall and apron may be precast as a separate piece from the top slab. Provide a minimum of 7 ~ #4 dowels in accordance with Index No. 201 "OPTIONAL CONSTRUCTION JOINTS".		7 of 7	"GENERAL NOTES", Note 8, deleted "Class I concrete" and substituted "Class NS concrete".
211	1 thru 5	Revised index completely 3 sheets added, Reinforcing configuration and C.I.P. details revised; precast and WWR details added. Changed Note 4 to allow 4'-0" round risers.	280	1 thru 3	Index was expanded due to font size change.
213	1 of 1	In PLAN view changed "1/2" Exp. Joint (Typ)" to "1/2" Preformed Joint Filler (Typ)".		1 of 3	"DISSIMILAR TYPES CONCRETE JACKET FOR CONNECTING DISSIMILAR TYPES OF PIPE AND CONCRETE PIPES WITH DISSIMILAR JOINTS" detail, added the note, "Alternate connection must be approved by the State Drainage Engineer."
218	2 of 2	"STEEL GRATE", "TOP VIEW", for the overall dimension on the left side of the grate, inserted "44 1/4" ". For the small dimension at the upper left corner of the grate, inserted "3 1/2" ".	282	1 thru 3	Index was expanded due to font size change.
219	1 of 2	In PLAN view and Section HH changed "Expansion Joint (Typ)" and "Expansion Material Joint" to "1/2" Preformed Joint Filler (Typ)".		1 of 3	"FRONT ELEVATION" and "SECTION AA" details changed "1/2" Exp. Matl. " to "1/2" Preformed Joint Filler".
220	1 of 3	"GUTTER INLET TYPE S", "SECTION BB", Changed the vertical dimension between the top of the inlet and the grate elevation from "5 1/2" to "4 1/2" ". "SECTION AA", at the top right corner, for precast thickness changed " 6" " to " 3" " (same as left side). "SECTION BB", at the top, changed "3'-11" Precast" to " 4'-3" Precast". "PLAN", at the top, changed " 3'-11" Precast to " 4'-3" Precast".	284	2 of 3	"PLAN" and "SECTION AA" details changed "1/2" Exp. Matl. " to "1/2" Preformed Joint Filler".
			287	1 of 1	Deleted note "1" and substituted the following: "1. Spillway to be paid for as Shoulder Gutter, LF." Deleted note "2", and substituted the following: "2. If spillway empties into an unpaved ditch the detail should be modified as necessary."
			288	1 thru 4	Sheet 3 is new. Renumbered other sheets.
			289	1 of 4	Changed all 3 occurrences of "Class I concrete" to "Class NS concrete".
230	1 of 2	In "PLAN" view changed "1/2" Exp. Joint (typ)" to "1/2" Preformed Joint Filler (Typ)". Section E-E, Changed 4Z15.9 shape to built up section (3.5 x 3 x 1/2L + 1/2 x 3 Bar) for grating.	288	1 of 1	New Index added "DEEP WELL INJECTION BDX".
231	1 of 3	"DITCH BOTTOM INLET TYPE B", "SECTION BB", upper left side, deleted the dimension "2'-6" (Min.)" and replaced with "1'-10" (Min.)".	289	6 of 7	Changed "FLARED ENDWALL" to "FLARED WINGWALL" and "STRAIGHT ENDWALL" to "STRAIGHT WINGWALL".
232	1 thru 7	Index was expanded due to font size change.	291	1 of 5	Changed "Class I Concrete" to "Class NS".
				5 of 5	Changed "Bond Beam" to "Link Slab", and "Class I Concrete" to "Class NS".
			292	2 of 14	"GENERAL NOTES" note 1, changed AASHTO LRFD Bridge Specifications, to "4th Edition"; added note 10.

**Revisions
Design Standards 2010**

Index Number	Sheet Number	Description	Index Number	Sheet Number	Description
295	1 of 1	"GENERAL NOTES" Note 2 changed "Specification Section 962" to "Specification Section 975".	421	1 of 3	Changed REFLECTIVE RAILING MARKERS note, "Reflective Railing Markers shall meet Specification Section 993. Install markers on top of the Traffic Railing along the centerline at the spacing shown in the table above. Reflector color (white or yellow) shall match the color of the near edgeline. The cost of the reflective markers shall be included in the Contract Unit Price for the Traffic Railing."
300	1 thru 2	Index was expanded due to change in font.			
304	6 of 6	Added alternate location of detectable warnings on linear ramps. Added note "On curb ramps, landings and flush transitions perpendicular to the curb line: Rows of domes shall be aligned with the centerline of the ramp. (See Pictorial View A)" at top of sheet. Added Rail Road Crossing PLAN view.	422	1 of 3	Added the following to the NAME, DATE AND BRIDGE NUMBER note: "The Name shall be as shown in the General Notes in the Structures Plans."; Changed REFLECTIVE RAILING MARKERS note.
305	1 & 4 of 4	Deleted bar spacing table and revised notes (Sheet 1); Changed width of outside lanes (Sheet 4).			Changed REFLECTIVE RAILING MARKERS note, "Reflective Railing Markers shall meet Specification Section 993. Install markers on top of the Traffic Railing 2" from the face on the traffic side at the spacing shown in the table above. Reflector color (white or yellow) shall match the color of the near edgeline. The cost of the reflective markers shall be included in the Contract Unit Price for the Traffic Railing."
307	2 of 3	"UTILITY CONFLICT PIPES THRU STORM SEWER STRUCTURES" changed to "UTILITY CONFLICT PIPES THRU STORM DRAIN STRUCTURES"			
310	1 of 2	"SIDEWALK WITH EDGE BEAM FOR SURFACE MOUNTED RAILINGS", "Clear Width", deleted "3' Min." and substituted "4' Min. *".	423	1 of 3	Added the following to the NAME, DATE AND BRIDGE NUMBER note: "The Name shall be as shown in the General Notes in the Structures Plans."; Bicycle Railing to "Special Height Bicycle Railing" and Post "B" to Post "B1".
		"NOTES FOR CONCRETE SIDEWALK ON CURBED ROADWAYS", deleted "Note 1", and substituted the following: "1. Sidewalks shall be constructed in accordance with Section 522 of the FDOT Standard Specifications. Public sidewalk curb ramps shall include detectable warnings and be constructed in accordance with Index No. 304. Detectable warnings are not required where sidewalks intersect urban flared turnouts."			"TRAFFIC RAILING-(32" VERTICAL SHAPE)", deleted the "REFLECTIVE RAILING MARKERS" note and substituted the following: "Reflective Railing Markers shall meet Specification Section 993. Install markers on top of the Traffic Railing 2" from the face on the traffic side at the spacing shown in the table above. Reflector color (white or yellow) shall match the color of the near edgeline. The cost of the reflective markers shall be included in the Contract Unit Price for the Traffic Railing."
		"Note 3" , deleted.		2 of 3	Changed Bicycle Railing to "Special Height Bicycle Railing" and Post "B" to Post "B1".
	2 of 2	"NOTES FOR CONCRETE SIDEWALKS ON UNCURBED ROADWAYS", Changed Note 2 to "Provide detectable warnings that extend the fullwidth of the sidewalk and 24" deep from the edge of pavement where sidewalks adjoin the following vehicular ways: side roads and streets driveways with signalized entrances driveways with entrance volumes greater than 600 vpd driveways with entrance speeds of 25 mph or greater right in - right out composite driveways.		3 of 3	Changed 83 degrees to 93 degrees in CONVENTIONAL REINFORCING STEEL BENDING DIAGRAM Cross-slope table.
400	1 thru 26	Index expanded by one sheet due to font size change and added new sheet 2, "APPROACH END ANCHORAGE DETAILS", Index renumbered.	424	1 of 7	Added the following to the NAME, DATE AND BRIDGE NUMBER note: "The Name shall be as shown in the General Notes in the Structures Plans."
	1 of 26	"GENERAL NOTES" Note 17 changed "Specification Section 971" to "Specification Section 975".	425	1 of 3	"TRAFFIC RAILING - (CORRAL SHAPE)", deleted the "REFLECTIVE RAILING MARKERS" note and substituted the following: "Reflective Railing Markers shall meet Specification Section 993. Install markers on top of the Traffic Railing 2" from the face on the traffic side at the spacing shown in the table above. Reflector color (white or yellow) shall match the color of the near edgeline. The cost of the reflective markers shall be included in the Contract Unit Price for the Traffic Railing."
	2 of 26	New sheet added showing limits of pay for guardrail, details of shoulder treatment and miscellaneous asphalt for guardrail approach end treatments.			Added the following to the NAME, DATE AND BRIDGE NUMBER note: "The Name shall be as shown in the General Notes in the Structures Plans."
	3 of 26	Corrected spelling of guardrail in last paragraph.			"TRAFFIC RAILING - (42" F SHAPE)", added the following note: "REFLECTIVE RAILING MARKERS: Reflective Railing Markers shall meet Specification Section 993. Install markers on top of the Traffic Railing 2" from the face on the traffic side at the spacing shown in the table above. Reflector color (white or yellow) shall match the color of the near edgeline. The cost of the reflective markers shall be included in the Contract Unit Price for the Traffic Railing."
	15 of 26	"LOCATIONS ON FRONT SLOPES", deleted the details for guardrail on slope and rubrail termination and the chart for lateral placement on slopes. (See sheet 26)			
	16 of 26	Deleted "REFLECTORS- DETAIL M" (See sheet 17)			
	26 of 26	Added "GUARDRAIL ON SLOPES", details for guardrail on slope and rubrail termination and the chart for lateral placement on slopes.	470	1 of 3	Added Field testing proof loads to the ADHESIVE BONDED ANCHORS AND DWELS note; "TRAFFIC RAILING-(THRIE BEAM RETROFIT) GENERAL NOTES & DETAILS", deleted the "BRIDGE NAME PLATE" note and substituted the following: "If a portion of the existing Traffic Railing is to be removed that carries the bridge name, number and or date, or if the installation of the Traffic Railing (Thrie Beam Retrofit) will obscure the bridge name, number and or date, then replace the information that has been removed or obscured, with 3" tall black lettering on white nonreflective sheeting applied to the top of the adjacent guardrail. The information must be clearly visible from the right side of the approaching travel lane. The sheeting and adhesive backing shall comply with Specification Section 994 and may comprise of individual decals of letters and numbers."
410	1 thru 25	Index completely revised and reorganized.			
411	2 of 10	Changed tangent offsets In Detail 'A' to "2.49'-Design Speed ≤45 mph; 1.76' - Design Speed ≥50 mph".			
	4 of 10	Changed tangent offsets In Detail 'B' to "2.49'-Design Speed ≤45 mph; 1.76' - Design Speed ≥50 mph".			
414	1 of 15	Updated Specification reference Section 971 to 975; Added steel option to ALTERNATE DESIGN note.			
	5 of 15	Added PTFE tape option to anchor bolt details.			
415	4 of 10	"NOTES FOR WALL END SHIELDING", Note 1, changed the second sentence to: "Except where the plans designate a particular type crash cushion for a specific location, the contractor has the option to construct any of the redirecive crash cushions listed on the Qualified Products List, subject to the uses and limitations described on their respective drawings."		3 of 3	Added the following note: "NEOPRENE PADS: Neoprene pads must be plain pads with a durometer hardness of 60 or 70 and meet the requirements of Specification Section 932, except that testing of the finished pad will not be required."
		"ANCHOR PLATE BDLTS", upper note, changed "?" to "3/4"."	471	2 of 4	Changed offset of 7/8" dia. anchor bolts to 2 3/4" from back edge of base plate in SECTION B-B.
420	1 of 3	Added the following to the NAME, DATE AND BRIDGE NUMBER note: "The Name shall be as shown in the General Notes in the Structures Plans."; Changed REFLECTIVE RAILING MARKERS note.	472	2 of 4	"SECTION A-A" and "SECTION B-B", changed "Resilient Pad" to "Neoprene Pad".
		Changed REFLECTIVE RAILING MARKERS note, "Reflective Railing Markers shall meet Specification Section 993. Install markers on top of the Traffic Railing 2" from the face on the traffic side at the spacing shown in the table above. Reflector color (white or yellow) shall match the color of the near edgeline. The cost of the reflective markers shall be included in the Contract Unit Price for the Traffic Railing."	473	2 of 4	"SECTION A-A" and "SECTION B-B", changed "Resilient Pad" to "Neoprene Pad".
			474	2 of 4	"SECTION A-A" and "SECTION B-B", changed "Resilient Pad" to "Neoprene Pad".
				4 of 4	"SECTION C-C", changed "Resilient Pad" to "Neoprene Pad".

**Revisions
Design Standards 2010**

Index Number	Sheet Number	Description	Index Number	Sheet Number	Description
475	2 of 4	"SECTION A-A" and "SECTION B-B", changed "Resilient Pad" to "Neoprene Pad".	600	3 of 13	LANE WIDTHS, in the second sentence, change the word "expected" to "excepted".
476	2 of 4	"SECTION A-A" and "SECTION B-B", changed "Resilient Pad" to "Neoprene Pad".		5 of 13	Changed note under "SIGN COVERING AND INTERMITTENT WORK STOPPAGE SIGNING"; added information for the use of the new "PROJECT INFORMATION SIGN".
480	1 of 2	"TRAFFIC RAILING-(VERTICAL FACE RETROFIT) GENERAL NOTES & DETAILS", added the following to the "ADHESIVE-BONDED ANCHORS AND DOWELS" note, "The field testing proof loads required by Specification Section 416 shall be 23,800 lbs. for Dowel Bars 6D on the inside face (traffic side) of the railing (1'-0" embedment) and 18,500 lbs for Dowel Bars 6D along the outside face of the traffic railing (5" min. embedment)." Added NEOPRENE PADS note. Also deleted the "REFLECTIVE RAILING MARKERS" note and substituted the following: "Reflective Railing Markers shall meet Specification Section 993. Install markers on top of the Traffic Railing 2" from the face on the traffic side at the spacing shown in the table below. Reflector color (white or yellow) shall match the color of the near edgeline."		6 of 13	GENERAL NOTES, deleted note 1, substituted the following: "1. All signs shall be post mounted when work operations exceed one day except for: a) Road closure signs mounted in accordance with the vendor drawing for the Type III Barricade shown on the QPL. b) Pedestrian advanced warning or regulatory signs mounted on sign supports shown on the QPL." "2. POST SIGN SUPPORT MOUNTING DETAILS", updated text to include a tolerance between sign supports. Insert "+/- 3" " after "1'-6" " and insert "+/- 6" " after "2'-6" ".
	2 of 2	CONVENTIONAL REINFORCING STEEL BENDING DIAGRAM, added Bars 5E, 5F and 4G for Index No. 484			POST AND FOUNDATION TABLE FOR WORK ZONE SIGNS, expanded Note 2 by adding: "unless otherwise specified in the vendor drawing on the QPL."
484	1-10 of 10	New Index added TRAFFIC RAILING (VERTICAL FACE RETROFIT) SPREAD FOOTING APPROACH			POST MOUNTED SIGN NOTES, added new notes 1 and 12.
500	2 of 2	"HALF SECTION" detail, deleted "Storm Sewer Mains" replaced with "Storm Drain Trunk Lines"		7 of 13	Added new sheet showing Project Information Sign and renumbered index.
501	3-9 of 9	Changed the REQUIRED TEST METHOD for Burst Strength, Soil-Geosynthetic Friction, Creep Reduction Factor & Joint Overlap to ASTM D 6706.	605	1 of 1	"GENERAL NOTES", deleted the text of "Note 8" and substituted the following: "The two channelizing devices directly in front and directly at the end of the work area may be omitted provided vehicles in the work area have high intensity rotating, flashing, oscillating or strobe lights operating."
	4 of 9	Updated values for COMTRAC 70.70; Deleted AMOCD 2006, 2016 & 2044; Added GEOTEX 315ST, 2x2HF, 4x4, 3x3HF, 4x4HF & 4x6 woven geogrids.			Added new heading "DURATION NOTE" and placed the following note under this heading: 1. ROAD WORK AHEAD sign may be omitted if all of the following conditions are met: a) Work operations are 60 minutes or less. b) Speed is 45 mph or less. c) No sight obstructions to vehicles approaching the work area for a distance of 600 feet. d) Vehicles in the work area have high-intensity, rotating, flashing, oscillating, or strobe lights operating. e) Volume and complexity of the roadway has been considered.
	5 of 9	Changed Joint Strength Overlap value to 1.2 for all Marafi products.			
	6 of 9	Deleted Application Usage 3 & 4 for SYNTEEN SF 11 & SF 12.			
	7 of 9	Added Fornir 20			
	8 of 9	Changed Creep Resistance and Creep Reduction Factors for TENSAR BX 1120, BX 1200, BX 1220 & BX 1500			
	9 of 9	Updated values for TENAX MS 220 & TENAX MS 330. Added Combigrid 30/30, Secugrid 20/20 & 30/30 extruded geogrids.	625	1 of 1	New Index added "TEMPORARY ROAD CLOSURE- 5 MINUTES OR LESS".
505	1-4 of 4	Sheet 3 is new. Renumbered other sheets.	655	1-3 of 3	New Index added "TRAFFIC PACING-LIMITED ACCESS".
515	5 of 7	In second symbolized note changed "Section 102-6" to "Section 102-8".	667	1-6 of 6	New Index added "TOLL PLAZAS".
	6 of 7	"PAVEMENT STRUCTURE FOR TURNOUTS AND AUXILIARY LANES TABLE 515-1", "NOTES", Note 5, Deleted "Class I concrete" substituted "Class NS concrete".	801	1 of 3	"GENERAL NOTES", Note 15 and 21, deleted "Class I" and substituted "Class NS".
518	3 of 3	Revised width of rigid pavement outside travellane and changed location of rumble strip.	802	1-3 of 3	Added tolerance to ground clearance; revised Notes 7a and 7b; rearranged sheets.
520	1 of 1	"GENERAL NOTES", Note 7, Deleted "Class I Concrete (Retaining Walls)" and substituted "Class NS Concrete"		1 of 3	"GENERAL NOTES", Note 6 and 13, deleted "Class I concrete" and substituted "Class NS concrete" for all occurrences.
546	1 of 6	Added detail "PLAN", "PICTORIAL" and ** note. Index sheets reordered.	803	1 of 1	"GENERAL NOTES", Note 4, deleted both occurrences of "Class I" and substituted "Class NS".
	5 of 6	Under "NOTES FOR 4-LANE DIVIDED ROADWAY", Note 1, changed reference from "Sheet 6" to "Sheet 2".	810	2 of 4	Deleted "Section 971" and substituted "Section 975" in ANCHOR RODS, NUTS AND WASHERS note.
600	2 of 13	OVERHEAD WORK, deleted "OPTION 4 - - -" and substituted the following: OPTION 4 (OVERHEAD WORK MAINTAINING TRAFFIC WITH NO ENCROACHMENT BELOW THE OVERHEAD WORK AREA) Traffic shall be detoured, shifted, diverted or paced as to not encroach in the area directly below the overhead work operations in accordance with the appropriate standard index drawing or detailed in the plans. This option applies to, but not limited to, the following construction activities: (a) Beam, girder and segment placement. (b) Deck form placement and removal. (c) Concrete deck placement. (d) Railing construction located at edge of deck. (e) Structure demolition. DEFINITIONS, added the following after definition of TRAVEL WAY: a. Travel Lane: The designated widths of roadway pavement marked to carry through traffic and to separate it from opposing traffic or traffic occupying other lanes. b. Auxiliary Lane: The designated widths of roadway pavement marked to separate speed change, turning, passing and climbing maneuvers from through traffic. CLEAR ZONE WIDTHS FOR WORK ZONES, deleted the text "travel" in the first sentence and substituted "traffic". Replaced chart "CLEAR ZONE WIDTHS FOR WORK ZONES".	811	3 of 3	Deleted "Section 971" and substituted "Section 975" in ANCHOR RODS, NUTS AND WASHERS note.
			812	2 of 4	Deleted "Section 971" and substituted "Section 975" in ANCHOR RODS, NUTS AND WASHERS note.
			820	1 of 1	Changed Top Rail to "Special Height Bicycle Railing" and added new Post "B2" for 3'-6" height Pedestrian/Bicycle Railing.
			821	1 of 1	Changed designation of 4'-6" tall railing to "Special Height Bicycle Railing" and added 3'-6" tall Pedestrian/Bicycle Railing.
			822	1 of 2	Changed designation of 4'-6" tall railing to "Special Height Bicycle Railing" and "Post B" to "Post B1"; Added "Post B2" details.
			850	1 of 5	Changed "Pedestrian Railing" to "Pedestrian/Bicycle Railing" and "Bicycle Railing" to "Special Height Bicycle Railing"; Added anchor bolt requirements to SHOP DRAWINGS note.
				2 of 5	Added "DETAIL FOR NON-CONTINUOUS RAILING AT CORNERS" detail. Changed Pedestrian and Bicycle Railing designation; maximum ramp length for slopes less than 6.25%; and minimum clear picket opening at post to 3/4".
				3 of 5	Changed Pedestrian and Bicycle Railing designation.
				4 of 5	Added requirement for set screw to be set flush against outside face of rail and 18-8 Alloy option in DETAILS "D" & "E", option to notch post in SECTION G-G, and 1/4" joint tolerance in DETAIL "D".
				5 of 5	Added DETAIL "F" and note (*) to ANCHOR BOLT TABLE. Changed Pedestrian and Bicycle Railing designation. Corrected height dimension on steps to top of nosing.

**Revisions
Design Standards 2010**

Index Number	Sheet Number	Description	Index Number	Sheet Number	Description
851	1 of 2	Changed Pedestrian and Bicycle Railing designation.	5204	1 of 1	Changed "Ribbed" to "Slotted" in PLUG DETAIL.
	2 of 2	Added requirement for set screw to be set flush against outside face of rail and 18-8 Alloy option in DETAIL "B". Changed field splice joint tolerance to 1/4" in DETAIL "B".	5205	1, 3, 4 & 6 of 7	Added note in Elevation Views to 'Extend post 2" above high side wall panel when post caps are shown in the plans'.
860	1 of 5	Changed "Pedestrian Railing" to "Pedestrian/Bicycle Railing" and "Bicycle Railing" to "Special Height Bicycle Railing"; Added anchor bolt requirements to SHOP DRAWINGS note. Added filler metal ER4043 to WELDING note.		2 of 7	Added tolerance between Top of Precast Collar and Auger Cast Pile; Changed "Composite Bearing Pads" to "Fiber Reinforced Bearing Pads".
	2 of 5	Added "DETAIL FOR NON-CONTINUOUS RAILING AT CORNERS" detail. Changed Pedestrian and Bicycle Railing designation; maximum ramp length for slopes less than 6.25%; and minimum clear picket opening at post to 3/4".		5 of 7	Changed "Composite Bearing Pads" to "Fiber Reinforced Bearing Pads".
	3 of 5	Changed Pedestrian and Bicycle Railing designation.	5206	7 of 7	Added "Octagonal Precast Collar" details and tolerance between Top of Precast Collar and Auger Cast Pile; Changed "Composite Bearing Pads" to "Fiber Reinforced Bearing Pads".
	4 of 5	Added requirement for set screw to be set flush against outside face of rail and 18-8 Alloy option in DETAILS "D" & "E"; option to notch post in SECTION G-G; 1/4" joint tolerance in DETAIL "D"; Type B (Nonwelded) connection detail in SECTION A-A. Changed Expansion Joint sleeve embedded length to 10" in DETAIL "D" and picket fillet weld size to 1/8", handrail and top rail fillet weld size to 1/4", and base plate fillet weld size to 3/8".	5207	1 of 1	Added "POST LENGTH WITH CAP" column, BARS D, P5 thru P8 to table and bar bending details for corner posts.
	5 of 5	Added DETAIL "F" and note (*) to ANCHOR BOLT TABLE. Changed Pedestrian and Bicycle Railing designation. Corrected height dimension on steps to top of nosing.	5210	1 of 1	New Index added "PRECAST SOUND BARRIERS-PRECAST POST CAPITAL".
861	1 of 2	Changed designation of 54" tall railing to "Special Height Bicycle Railing".	5211	2 of 5	Changed NAME, DATE AND BRIDGE NUMBER note, and "Ribbed" to "Slotted" in NEOPRENE DIAPHRAGM PLUG DETAIL. Added REFLECTIVE RAILING MARKERS note and SELECTIVE RAILING MARKER SPACING table.
	2 of 2	Added requirement for set screw to be set flush against outside face of rail and 18-8 Alloy option in DETAIL "B". Changed field splice joint tolerance to 1/4" and "Steel Sleeve" to "Aluminum Sleeve" in DETAIL "B".	5212	3 of 3	Changed "Ribbed" to "Slotted" in NEOPRENE DIAPHRAGM PLUG DETAIL. Corrected Anchor Pin diameter on FIRE HOSE ACCESS DETAIL.
870	1 of 5	Deleted Pedestrian and Bicycle designations from DESIGN LIVE LOADS and ALTERNATE DESIGN notes.	5300	2 of 2	Added note for "Full Depth Structural Asphalt" above junction slab and changed coping dimension to 6" Min.
	2 of 5	Deleted 4'-6" Bicycle Railing option and "***" note. Changed maximum ramp length for slopes less than 6.25%.		3 of 19	Increased max. gap at back of precast coping and added timber blocking.
	3 of 5	Deleted 4'-6" Bicycle Railing option.		6 of 19	Added note for "Full Depth Structural Asphalt" above junction slab and increased max. gap at back of precast coping.
	4 of 5	Added requirement for set screw to be set flush against outside face of rail and 18-8 Alloy option in DETAILS "D" & "E"; and 1/4" joint tolerance in DETAIL "D". Deleted Intermediate Rails from DETAILS "B" and "C".		7 of 19	Added note for "Full Depth Structural Asphalt" above junction slab.
	5 of 5	Added DETAIL "F". Deleted 4'-6" Bicycle Railing option. Corrected height dimension on steps to top of nosing.	11200	12 & 15 of 19	Increased max. gap at back of precast coping. Corrected size of Bar 5U1 in BILL OF REINFORCING TABLE
880	1 of 5	Deleted Pedestrian and Bicycle designations from DESIGN LIVE LOADS and ALTERNATE DESIGN notes.		1-2 of 2	Deleted sheet 2
	2 of 5	Deleted 4'-6" Bicycle Railing option and "***" note. Changed maximum ramp length for slopes less than 6.25%.		1 of 2	Revised and rearranged notes, sheet renumbered to 1 of 2.
	3 of 5	Deleted 4'-6" Bicycle Railing option.		2 of 2	Renumbered sheet 3 of 3 to sheet 2 of 2 revised and rearranged notes. Deleted "Class 1 (Special) Concrete" replaced with "Class 1 Concrete".
	4 of 5	Added requirement for set screw to be set flush against outside face of rail and 18-8 Alloy option in DETAILS "D" & "E"; and 1/4" joint tolerance in DETAIL "D". Deleted Intermediate Rails from DETAILS "B" and "C".	11300	1 of 1	Hanger table values revised; connection bolt size revised; sign depth for horizontal splice changed to 10'. U-Bolt material spec (A325) added to Typical Detail of Sign & Truss Connection.
	5 of 5	Added DETAIL "F". Deleted 4'-6" Bicycle Railing option. Corrected height dimension on steps to top of nosing.	11310	1 of 5	Deleted A307 bolts and Palnut (Note 4e). Changed foundation concrete (Note 7). Changed to 1/2" mesh (Note 9). Deleted grout pad and notes (former Notes 7c & 9). Added CSL tube note (Note 14).
5100	2 of 2	Changed to plastic sleeve expansion joint and "Premoulded Expansion Material" to "Preformed Joint Filler". Changed wall and expansion joint key.		2 of 5	Changed foundation standoff distance and changed drilled shaft detail. Deleted grout pad and added wire screen. Added CSL tubes. Changed FC & FL reinforcing.
5200	1 of 1	Post caps added to note C.1.b; Changed note K.2 to allow 8 ft height panels. Added note K.11; Changed notes H.1, H.2 and D.2; Deleted note H.3.		5 of 5	Changed bolt spacing connection details.
5201	1 of 1	Texture Type "I" (Cut Coral Block) added.	11320	1 of 5	Deleted A307 bolts and Palnut (Note 4e). Changed foundation concrete (Note 7). Changed to 1/2" mesh (Note 9). Deleted grout pad and notes (former Notes 7c & 9). Added CSL tube note (Note 14).
5202	1 of 4	Added precast post cap; Changed clearance tolerance on stepped panel and Neoprene Pad options.		2 of 5	Changed foundation standoff distance. Deleted grout pad and added wire screen.
	3 of 4	Changed #4 Bar Mark to Bars P5 and P6 for Pile/Post Options A, B, & E; changed Texture Thickness to 1 1/4" Max.		4 of 5	Changed bolt spacing connection details.
5203	1 of 5	Added precast post cap; Changed clearance tolerance on stepped panel and Neoprene Pad options.		5 of 5	Changed drilled shaft detail. Added CSL tubes.
	3 of 5	Changed #4 Bar Mark to Bars P5 & P6 for Pile/Post Options A, B & E, and changed texture thickness dimension to 1/4" Max.	11860	1 of 8	Changed SINGLE COLUMN GROUND SIGN NOTES, Note 11, and GUIDE TO USE THIS STANDARD, Note 4 and example. Modified concrete classification. Modified "ALUMINUM COLUMN (POST) SELECTION TABLE".
	4 of 5	New sheet added for 45 degree corner post.		2 of 8	Changed maximum limits of sign cluster area and width in NOTE.
	5 of 5	Renumbered from Sheet 4 of 4.		3 of 8	Added Aluminum Soil Plate details and notes. Changed Post and Foundation Table depth values. Modified "ALUMINUM COLUMN (POST) SELECTION TABLE".
				4 of 8	Deleted "Signs at 90°" note. Added "For" note. Changed number of Z-brackets for STOP and RECTANGULAR sign. Changed '1" Min.' to '0" Min.' and sign panel edge distance in VIEW A-A. Modified U-bolt size. Changed panel overhang length.
				5 of 8	Modified "DRIVEN POST DETAIL IN CONCRETE".
			17302	1 of 1	CASE II, and CASE VIII dimensions and notes revised.
			17328	1 of 1	Weigh Station and combination Weigh Station and Inspection Station signing details separated.

**Revisions
Design Standards 2010**

Index Number	Sheet Number	Description	Index Number	Sheet Number	Description
17344	2, 3, 4 & 6 of 6	SCHOOL SIGNS AND MARKINGS, on each sheet, in the Distance table at the bottom of the sheet, deleted the "A" column. Also deleted the "A" dimension from the detail drawings.	17725	1 of 2	Round pole note revised; pole height dimensions added to Type P-III through P-VIII; Copper Ground note changed.
17345	2 of 4	NORMAL TAPERED ENTRANCE WITH ADDED LANE, note in lower left corner, arrow now points to the reflective markers on the LEFT side of the ramp.		2 of 2	Notes revised and rearranged, D(feet) changed to H(feet) in both tables.
	4 of 4	Deleted note 2	17727	1-2 of 2	Schedule 40 aluminum pipe (T6061) added as an alternate to stainless steel pipe in assembly details and signalhead notes. Added backplates to signalhead details.
17346	1-14 of 14	Completely revised and renumbered.	17736	1 of 1	Added notes 5 & 6.
17347	1-4 of 4	New Index BICYCLE MARKINGS added.	17743	1 of 3	Updated assembly dimensions. Changed drilled shaft reinforcing.
17349	1 of 1	Case I and Case II revised; 18" x 18" marker detail revised; notes at bottom right revised.		2 of 3	Updated assembly dimensions. Changed drilled shaft reinforcing. Changed T3-BF.
17355	1 of 11	Revised signs FTP-9A-06 & FTP-9B-06 and notes.		3 of 3	Updated assembly dimensions. Changed drilled shaft reinforcing.
	7 of 11	For all signs with 1-800 phone number, deleted "1-800-998-RIDE" and substituted "1-8XX-XXX-XXXX" and below each sign added note: "Design Project Manager or Transit Administrator will supply correct 1-8XX number".	17745	1 of 5	QPL requirements added in new note 17; added backplates to pole detail; Notes 6 & 14 revised, deleted note 19.
	8 of 11	Revised sign FTP-68A-06, bolt holes located outside of sign message, notes revised. Sign FTP-69-06 and FTP-68B-06 message and spacing revised.	17748	2 of 5	Revised foundation reinforcing details, Section AA, Section DD and Foundation Plan details.
	9 of 11	Revised sign FTP-82-08 and arrow detail. Added Sign FTP-83-08.		1 of 1	Option 1 deleted and Options 2 and 3 renumbered; Note 1 revised. Added backplates to signalhead displays.
17356	1 of 1	Removed signalhead from detail. Single point attachment details deleted from Index. (Deleted sheet 1.)	17784	1 of 2	Dimensions revised on Figures A & B. Note 5 and Note to Designers revised.
17359	1 of 2	Changed delineators to object markers; revised reference notes; sign W13-1 made optional. RURAL NARROW BRIDGE TREATMENT, changed the DM3L on the right side of the roadways to an DM3R.	17890	2-3 of 3	Revised details and spacing for signs FTP-68A-06 and FTP-68B-06, also located bolt holes outside of sign message.
	2 of 2	Notes revised; inserts reorganized	17900	7 of 7	Added backplates to signalhead displays.
17500	1 of 3	Deleted concrete pole detail, added METAL POLE DETAIL AND WIRING DIAGRAM.	18111	1-2 of 2	Changed pole type callouts, deleted "N-III" and substituted "P-III".
	2 of 3	Note 7, deleted "class I Concrete (Miscellaneous)" replaced with "Concrete and reinforcing for slabs around poles and pullboxes shall be included in the price for pullbox or pole."	18113	1-2 of 2	Index totally revised.
	3 of 3	Note 7, deleted "class I Concrete (Miscellaneous)" replaced with "Concrete and reinforcing for slabs around poles and pullboxes shall be included in the price for pullbox or pole."	20110	1 of 1	Index totally revised.
17501	1 of 1	Deleted note 28.	20199	1 of 1	Changed Insert Detail for Diaphragm Reinforcing.
17502	3 of 7	Changed Note 9. Added Notes 10 & 11. Changed Notes 11 & 12. Deleted grout pad notes (former Notes 4 & 9). Added CSL tube note (Note 11).	20199	1 of 1	Changed BEAM CAMBER AND BUILD-UP NOTES.
	4 of 7	Added ID plate and changed base plate thickness. Deleted grout pad. Changed drilled shaft reinforcing.	20210	2 of 2	Added "Type Q" Epoxy to Note 9.
	5 of 7	Changed Weld symbol in SECTION A-A. Added padlock tab to HANDHOLE RING. Added Section E-E detail and bottom baseplate washer to SECTION C-C. Deleted grout pad and added wire screen. Added CSL tubes.	20299	1 of 1	Changed BEAM CAMBER AND BUILD-UP NOTES.
	6 of 7	Grout notes and details removed, new wire screen.	20500	1 of 1	Added Type C Pads for larger skew ranges. Changed specification of elastomer from "durometer" to "shear modulus".
	7 of 7	Note 3, changed "Concrete class" to "concrete NS"	20501	1 of 1	Changed Note 4.
17503	1 of 1	Index deleted.	20502	1 of 1	Changed Note 4.
17504	1 of 1	Dimensions 5'-6" added for height of meter base. Pole type changed from type "N" to type "P".	20602	1 of 1	Changed EDC location to 1D from tip of pile.
17505	1 of 2	Mercury Vapor Luminaires changed to Induction Luminaires. Luminaire chart deleted, dimensions revised on spacing detail note and added to structure detail.	20900	2 of 2	Changed coping width and End Bent lug from 6" to 5½" thickness.
17515	1 of 8	Added median barrier mounted light poles. Moved notes to sheet 2.	20910	2 of 2	Changed coping width and End Bent lug from 6" to 5½" thickness.
	2 of 8	New Sheet for Notes. Change Note 7 for QPL Criteria. Modified concrete classification. Added notes for median barrier mounted light pole and foundation.	21100	1 of 3	Deleted redundant notes from Specification Section 458.
	3 of 8	Sheet renumbered from 2 to 3. Added double arm configuration to ARM ELEVATION.		3 of 3	Changed Sidewalk Cover Plate edge treatment.
	4 of 8	Allowed fusion weld reinforcing cage (*) and changed foundation concrete note. Added 1" dimension to Double Nuts in FOUNDATION. Modified concrete classification. Renumbered sheet from 3 of 3 to 4 of 8.	21110	1 of 2	Deleted redundant notes from Specification Section 458. Changed last line of title of bottom left detail to "DECK WITH SLOPES 2% OR GREATER".
	5-8 of 8	New Sheets for median barrier mounted light pole.		2 of 2	Changed Sidewalk Cover Plate edge treatment.
17600	2 of 3	Added detail for pole foundation to be used only behind guardrail.	21200	1 of 2	Added "Anchor Plate (dashed lines) (provide Design) to ELEVATION VIEW and TYPICAL SECTION. Added design of anchor bolts and accessories.
	3 of 3	GENERAL NOTES, note 2, changed "Class II Concrete" to "Class I Concrete"; changed note 4.		2 of 2	Added design of anchor bolts and accessories.
17723	1 of 3	Changed Note 5i, 6 and 7. Added Note 8. Deleted grout pad and notes (former Notes 4d & 7). Added CSL tube note (Note 9).	21600	1 of 7	Clarified INSTRUCTIONS TO DESIGNER for variable end span lengths.
	2 of 3	Changed number of bolts in VIEW B-B, number and size of foundation reinforcing bars, and TABLE OF STRAIN POLE VARIABLES. Added foundation standoff distance and washer for base plate. Deleted grout pad and added wire screen. Added CSL tubes. Changed drilled shaft reinforcing.	21802	3 of 7	Added vertical dimensions between deck surface and underside of bearings, including depth of Truss Panel.
	3 of 3	Changed note in VIEW E-E; Added ¼" and ⅜" cable clamps and changed weld criteria. Changed clevis size.	21803	1 of 1	Changed "Methyl Methacrylate" to "High Molecular Weight Methacrylate".
				1-2 of 3	Revised call-outs for Grout Outlets; Changed "Methyl Methacrylate" to "High Molecular Weight Methacrylate".
				3 of 3	Shrink wrap deleted from Duct Coupler Detail. Revised call-outs for Duct Couplers; Changed "Methyl Methacrylate" to "High Molecular Weight Methacrylate".

A Area or Amperes
AAA American Automobile Association
AADT Annual Average Daily Traffic
AASHTO American Association Of State Highway Officials
AASHTO American Association Of State Highway And Transportation Officials
ABC Asphalt Base Course
Abd. Abandoned
ABS Acrylonitrile-Butadiene-Styrene Pipe
AC, Ac. Acre
AC or Asph. Conc. Asphaltic Concrete
Accel. Acceleration
ACI American Concrete Institute
Act. Actuated
ADA The Americans With Disabilities Act
Adh. Adhesive
Adj. Adjust
ADT Average Daily Traffic
AFAD Automatted Flagger Assistance Device
Agg. Aggregate
Ah. Ahead
AISC American Institute Of Steel Construction
Alt. Alternate
Al. Aluminum
AM 12:00 Midnight Until 11:59 Noon
ANSI American National Standards Institute
ADS Apparent Opening Size
Appl.. Applied, Application
Apprh. Approach
Approx. Approximate
ARTBA American Road & Transportation Builders Association
Artf. Artificial
Asph. Asphalt
Assem. Assembly
Assn. Association
Assoc. Associate, Association
ASTM American Society For Testing And Materials
ATPB Asphalt Treated Permeable Base
Attn. Attention
Attnuatr. Attenuator
Aux. or Auxil. Auxiliary
Ave. Avenue
AWG American Wire Gauge
AWS American Welding Society
Az Azimuth

B to B Back to Back
Basc. Bascule
Bd. or Bnd. Bond or Bonded
BC Bottle Cap or Bolt Circle
B/C, B.C. Back Of Curb
BCCMP Bituminous Coated Corrugated Metal Pipe Culvert
BCPA Bituminous Coated Pipe Arch Culvert
BCPCMP Bituminous Coated And Paved Corrugated Metal Pipe Culvert
BCPPA Bituminous Coated And Paved Pipe Arch Culvert
BCT Breakaway Cable Terminal
BCWE Base Clearance Water Elevation
BE Buried Electric
Beg. Begin
Bit. Bituminous
Bk. Back
BL, BLC, or B̄ Base Line, Base Line Control
Bldg. Building
Blkhd. Bulkhead
BLDN Begin Length Of Need
Blvd. Boulevard
BM Bench Mark
Bndry. Boundary
Bdr. Border
Bot. Bottom
BO Basin Outlet
BOS Beginning Of Survey
BP Borrow Pit
Bq. Becquerel

Br. Bridge
Brg. Bearing
Brkwy. Breakaway
BT Buried Telephone Cable or Duct
Btfly. Butterfly
BW Barbed Wire, Bottom Width or Both Ways
C Cantilever Length, Cut, Colorless, Coulomb or Cycle Length
°C Degree Celsius
C & G Curb And Gutter
CA Coarse Aggregate
Cap. Capacity
CAP Corrugated Aluminum Pipe
Caps. Capital Letters
CASP Corrugated Aluminized Steel Pipe
CATV Cable Television
CB Catch Basin
CBC Concrete Box Culvert
CBS Concrete Box Structure
CC, C/C, C to C, or C.C. Center to Center, Crash Cushion
CCEW Center to Center Each Way
CCTV Closed-Circuit Television
CD Cross Drain, Cross Direction (Geotextiles)
cd Candela
Cem. Cement or Cemetery
Cem'd. Cemented
CFS Cubic Feet Per Second
Ch. Channel
Chchg. Channel Change
Chg. Changeable
CI Cast Iron
CIP Cast Iron Pipe
CIPL, C.I.P., C-I-P Cast In Place
circ. Circumference
Ckt. Circuit
Cl. or Clear Clearance
CL, C/L or C̄ Center Line
CM Concrete Monument
CMB Concrete Median Barrier
CMP Corrugated Metal Pipe
CMPA Corrugated Metal Pipe Arch
Co. County or Company
Col. Column
Com. Commercial or Common
CDMM Committee or By Committee
Comp. Composite
Con. Connect or Connection
Conc. Concrete
Const. Construct or Construction
Contrl. Controller
Cont. Continuation
Contr. Contractor
Coord. Coordinate
Cor. Corner
Corr. Corrugated
CP Concrete Pipe
CPE Corrugated Polyethylene Pipe
CPT Cone Penetration Test
CR Control Radius or County Road
CRA Clear Recovery Area
Crs. or Cse. Course
CS Curve To Spiral
CSP Corrugated Steel Pipe
CT Clear Trunk
CTPB Cement Treated Permeable Base
Ctivr. Cantilever
Ctr., Ctrs. Center
CU or Cu Copper
Culv. Culvert
Cwt. Hundredweight
CY, Cu. Yd., CY, or C.Y. Cubic Yard
Cyl. Cylindrical

D Degree Of Curvature, Depth, Density, Distance, Diameter or Directional Distribution
DA Drainage Area or Deflection Angle
DBH Diameter At Breast Height
DBI Ditch Bottom Inlet
Dbl. Double
DCS Degree Of Curvature (Spiral)
DD Dry Density
DDHV Directional Design Hour Traffic
Decel. Deceleration
Deg. Degree
Delin. Delineators
Demobl. Demobilization
Dept. Department
Det. Detour, Detection, Detectable
DFE Design Flood Elevation
DGN or Dgn. Design
DHV Design Hourly Volume
DHW Design High Water
DT Ditch
DI Drop Inlet
Dia. or D Diameter
Dim. Dimension
Disp. Disposal
Dist. Distance
DLS District Location Surveyor
DMM Domestic Mail Manual
DOT Department Of Transportation
DPI or D.P.I. Ditch Point Intersection
Dr. or DR. Drain, Drive or Design Review
DR Design Review
Driv. Driven
Drwy. Driveway
DS Design Speed
DSL Design Service Life
Dwg. Drawing
E East or External Distance
e Rate Of Superelevation
E to E End to End
EA or Ea. Each
EB Eastbound
EIA Electronic Industries Alliance
El. or Elev. Elevation
Elast. Elastomeric
Elec. Electric
Ellip. Elliptical
Embk. Embankment
Emul. Emulsified
Encl. Enclosure
Engr. Engineer
EOS End Of Survey or Equivalent Opening Size
E.P. or EOP Edge Of Pavement
EPDM Ethylene Propylene Diene Monomer
Eq. Equation or Equal
Equip. Equipment
Esmt. Easement
Est. or Estm. Estimate
Est. Establish or Established
Etc. or etc. Et Cetera (And So Forth)
ETP Electronic Tough Pitch
EW Endwall
Ex. Except, Example
Exc. or Excav. Excavation
Exist. Existing
Exp. Expansion
Ext. Extension
Exwy. Expressway

The abbreviations listed are the standard for contract plans production. This list is not all inclusive. Other Department accepted abbreviations may be used when deemed more appropriate. Where special abbreviations are used a descriptive tabulation may be necessary in the plans.



2010 FDOT Design Standards

STANDARD ABBREVIATIONS

Last Revision	Sheet No.
07/01/09	1 of 3
Index No.	
001	

F	Fill, Farad	HW or H.W.	High Water or Hot Water	M	Mass, Middle Ordinate Length or Mega	N m	Newton Meter
F or Final	Final Quantity	Hwy.	Highway	m	Meter or Milli	No.	Number
F & I	Furnish & Install	Hyd.	Hydraulic	m ²	Square Meter or Meter Square	Nom.	Nominal
F to F	Face to Face	Hz	Hertz	m ³	Cubic Meter or Meter Cubed	Norm.	Normal
FA	Federal Aid or Fine Aggregate			m ³ /m	Cubic Meter Per Meter	N.P.	Non Plastic
FAC	Florida Administrative Code	I	External Angle (Delta), Interstate	m/s	Meters Per Second	NPS	Nominal Pipe Size
FAP	Federal Aid Project	Intchg. or Ichg.	Interchange	Mach.	Machine	NPT	National Pipe Thread
FC	Friction Course	IES	Illuminating Engineering Society	Maint.	Maintenance	NRCP	Non-Reinforced Concrete Pipe
FD	French Drain	ID, I.D.	Inside Diameter or Identification	Matl.	Material	NS	Non Stress, Not Suitable or Near Side
Fdn.	Foundation	IMC	Intermediate Metal Conduit	Max.	Maximum	NT, N&T	Non Traffic, Nail & Tin
FDDT	Florida Department Of Transportation	In.	Inch or Inches	MB	Median Barrier	NTS	Not To Scale
FE	Floor Elevation	Inc.	Incorporated or Including	MBM	Thousand (Feet) Board Measure	NW	Northwest
Fed.	Federal	Incl. or Inc.	Included	MD	Machine Direction (Geotextiles)		
Fert.	Fertilizer	Ind.	Industry or Industrial	Med.	Median	Opass	Overpass
FES	Flared End Section	INV. or Inv.	Invert	Mega	One Million	Q to Q, o to o or O.D.	Out to Out
FETS	Flared End Terminal Section	IP	Iron Pipe	Memb.	Member	QA	Overall
FH	Fire Hydrant	Install.	Installed	MES	Mitered End Section	Q.B.G.	Optional Base Group
FHWA	Federal Highway Administration	Isect.	Intersection	Mess.	Message	QC or Q.C.	On Center
Fig.	Figure	Isl.	Island	Mfg.	Manufactured or Manufacturer	OD or O.D.	Outside Diameter
Fin.	Finish	IR	Iron Rod	MG	1000 Gallons	OE	Overhead Electric
F.L., FL or \bar{F}	Flow Line	ITE	Institute Of Transportation Engineers	MH, M.H.	Manhole, Mounting Height	OH, OHD or Ohd.	Overhead
FL, Fl. or Fla.	Florida	ITS	Intelligent Transportation Systems	MHW	Mean High Water	Opt.	Option, Optional or Optically
Flex.	Flexible			μ	Micro	OT	Overhead Telephone
FNQ	Fuse (Type Slow Burn)	J	Joule	Mi.	Mile	Oz.	Ounce
FDC	Fiber Optics Cable	JB	Junction Box	Micro	One-Millionth	Ω	Ohm
FPM or fpm	Feet Per Minute	Jct.	Junction	Mid.	Middle	P	Passenger Car & Light Delivery Truck
FPS or fps	Feet Per Second	Jt.	Joint	Mil	One-Thousandth Of An Inch	P or Plan	Plan Quantity
FR or Fr.	Frame			Mil.	Military	Pa	Pascal
Frang.	Frangible	K	Design Hour Factor or Kelvin	Milli	One-Thousandth	Par.	Parallel
Freq.	Frequency	k	Kilo (prefix)	Min.	Minimum or Minute	Pa.s	Pascal Second
F.S.	Florida Statutes	kg	Kilogram	Misc.	Miscellaneous	Part.	Participation or Partition
Ft.	Foot or Feet	kg/m	Kilogram Per Meter	mL	Milliliter	Pavt.	Pavement
FTB	Floating Turbidity Barrier	kg/m ²	Kilogram Per Square Meter	MLW	Mean Low Water	PC	Point Of Curvature
FTBA	Florida Transportation Builder Association	kg/m ³	Kilogram Per Cubic Meter	mm	Millimeter	PCBC	Precast Concrete Box Culvert
FTP	Florida Traffic Plans	Kilo	One Thousand	mobl.	Mobilization	PCC	Point Of Compound Curvature or Plain Cement Concrete
Furn.	Furnish	Kip	1000 Pounds	Mod.	Modify or Modified	PCE	Permanent Construction Easement
		km	Kilometer	Mol	Mole	PE	Professional Engineer
		km/h	Kilometer Per Hour	Mon.	Monument	Ped	Pedestrian or Pedestal
G	Giga or Gauss	kn	Knot	MOT	Maintenance Of Traffic	Pen.	Penetration
g	Gram or Gravity	kN	Kilonewton	MP	Mile Post	PG	Profile Grade
Galv.	Galvanized	kPa	Kilopascal	MPa	Megapascal	PGL	Profile Grade Line
Ga.	Gauge or Gage	ksi	Kips Per Square Inch	MPH or mph	Miles Per Hour	Ph.	Phase
Ga. or Gal.	Gallon	kV	Kilovolt	MSL	Mean Sea Level	pH	Measure Of Acidity or Alkalinity
Gar.	Garage	kVA	Kilovolt Ampere	MSTCSD	Minimum Specifications For Traffic Control Signal Devices	PI	Point Of Intersection
GD	Gutter Drain	kWh	Kilowatthour			Pkg.	Parking
GFI	Ground Fault Interrupter			Mtd.	Mounted	Pkgwy.	Parkway
GIP	Galvanized Iron Pipe	L	Length, Length Of Curve, Liter, Left	MUTCD	Manual On Uniform Traffic Control Device	PL or \bar{P}	Property Line or Plate
GM	Gas Main	2-L	Two-Lane	MUTS	Manual On Uniform Traffic Studies	PM	12:00 Noon Until 11:59 Midnight
GP	Grade Point	2L1W	Two-Lane One-Way			POC	Point On Curve
Gr.	Grade, Guardrail or Grate	2L2W	Two-Lane Two-Way	N	North or Newton	PDST	Point On Semi-Tangent
Gr. or Gro.	Gross	LA or L/A	Limited Access	N/m	Newtons Per Meter	POT	Point On Tangent
GRC	Galvanized Rigid Steel Conduit	Lat.	Lateral or Latitude	N/m ²	Newtons Per Square Meter	PP	Power Pole
Grd.	Ground	Lb.	Pound	N/m ³	Newtons Per Cubic Meter	PPB	Pier Protection Barrier
GRI	Geosynthetic Research Institute	LBS.	Pounds	N/mm ²	Newtons Per Square Millimeter	Pr.	Pair
gross km	Gross Kilometer	lb/sy	Pounds Per Square Yard	NA or N/A	Not Available or Not Applicable	PRC	Point Of Reverse Curvature
Gr. Wt. or gr. wt.	Gross Weight	LBR	Limerock Bearing Ratio	N & C	Nail & Cap	Prct.	Precast
Gttr.	Gutter	LC	Long Chord	N & D	Nail & Disk	Prest.	Prestressed
		LED	Law Enforcement With Flashing Lights And Radar	NAVD	National American Vertical Datum	Prob.	Probability
H	Henry	LFD	Load Factor Design	NB	Northbound	Prod.	Product, Production, Producer or Produced
h	Hour or Hecto	Lgth.	Length	NC	National Coarse or Normal Crown	Prog.	Program or Progression
ha	Hectare	Lin.	Linear	NCHRP	National Cooperative Research Program	Proj.	Project or Projection
HAR	Highway Advisory Radio	lm	Lumen	NDCBU	Neighborhood Delivery And Collection Box Unit	PRM	Permanent Reference Monument
HB	Hay Bales	Lmrk.	Limerock	NE	Northeast	Prop.	Proposed
HC	Horizontal Clearance	LDS	Limit Of Clear Sight	net km	Net Kilometer	Prov.	Provisions
HD	High Density or Heavy Duty	Loc., LO	Location	NEMA	National Electrical Manufacturers Association	PRS	Portable Regulatory Sign
HD or Hd.	Head	Long.	Longitude	NGVD	National Geodetic Vertical Datum of 1929	PS & E	Plans, Specifications And Estimates
HDPE	High Density Polyethylene	LRFD	Load Resistance Factor Design	NGS	National Geodetic Survey	PSF or psf	Pounds Per Square Foot
Hdl.	Headwall	LS	Length Of Spiral	NHS	National Highway System	PSI or psi	Pounds Per Square Inch
HH	Heavy Hex	LT	Left Turn	NHW	Normal High Water	PT	Point Of Tangency or Pressure Treated
Hndrl	Handrail	Lt.	Left	NIC	Not In Contract	PVC	Polyvinyl Chloride
HDA	Hand/Off/Automatic	Ltd.	Lighted or Limited	NJ	New Jersey	PW	Pressure Water
Horiz. or Hor.	Horizontal	Lum.	Luminaire				
HP	High Pressure or Horsepower	L/W	Lightweight				
Hr.	Hour	lx	Lux				
HS	High Strength						
HSHV	High Strength Horizontal Vertical						
Hse.	House						
Ht.	Height						

The abbreviations listed are the standard for contract plans production. This list is not all inclusive. Other Department accepted abbreviations may be used when deemed more appropriate. Where special abbreviations are used a descriptive tabulation may be necessary in the plans.



STANDARD ABBREVIATIONS

Q Peak Discharge or Flow Volume
 QPL Qualified Products List

R Right
 R or Rad. Radius
 R or Rng. Range
 rad Radian
 rad/s Radian Per Second
 RBAC Rock Base Asphaltic Concrete
 RBST Rock Base Surface Treatment
 RC Reverse Crown
 RCP Reinforced Concrete Pipe
 RCPA Reinforced Concrete Pipe Arch
 Rd. Road or Round
 Rdsd. Roadside
 Rdwy. Roadway
 Rec. Recovery
 Rect. Reticuline or Rectangular
 Ref. Reference
 Refl. Reflective
 Reg. Region, Regular, Registered or Regulation
 Reinf. Reinforced or Reinforcing
 Rejuv. Rejuvenation
 Reloc. Relocated
 Rem. Removal
 Repl. Replace
 Req. or Reqd. Required
 Res. Residence or Residential
 RGS Rigid Galvanized Steel
 RHW Insulation (Moisture & Heat Resistant Rubber)
 RM Reference Monument
 r/min Revolution Per Minute
 RP Reference Point
 rpm Revolution Per Minute
 RPM Raised Reflective Pavement Markers
 r/s Revolution Per Second
 RR Railroad
 RSDU Radar Speed Display Unit
 Rsf. Resurface
 Rt. Right
 RU Rack Unit
 R/W, RDW Right Of Way
 RX Receive

S or s Speed, South, Siemens, Or Second
 SAHM Sand-Asphalt Hot Mix
 SAN or San. Sanitary
 SB Southbound
 SBAC ShellBase Asphaltic Concrete
 SBRM Sand Bituminous Road Mix
 SBST ShellBase Surface Treatment
 SC Seal Coat or Spiral To Curve
 Sch. Schedule
 SCST Sand-Clay Surface Treatment
 SD Side Drain, Storm Drain
 SE Southeast
 Sec. Second
 Sect. Section
 Sed. Sediment
 Sep. Separator
 Seq. Sequential
 Serv. Service
 SF Adjustment Factor In Percent, Silt Fence
 SG Subgrade
 SG Specific Gravity
 Sh. or Sht. Sheet
 Shldr. Shoulder
 SHW Seasonal High Water
 SIP Stay In Place
 SP Superpave
 Spa. Space
 Spcg. or Sp. Spacing
 Spec. Specification
 SPT Standard Penetration Test
 Sq. Ft., SF, or S.F. Square Foot
 Sq. In. Square Inch
 Sq. Yd., SY or S.Y. Square Yard
 SR or S.R. State Road
 SRAP Spiral Rib Aluminum Pipe

SRASP Spiral Rib Aluminized Steel Pipe
 SRCP Steel Reinforced Concrete Pipe
 SRD State Road Department
 SRSP Spiral Rib Steel Pipe
 SS Sanitary Sewer
 SSMD Solid State Modular Design
 ST Surface Treatment or Spiral To Tangent
 St. or ST. Street
 Sta. Station
 Stab. Stability or Stabilization
 STB Staked Turbidity Barrier
 Std. Standard
 Stg. Strong
 Stge. Storage
 Stl. Steel
 Str. Structure
 Sty. Story
 SU Single Unit Trucks
 Sub. or Subs. Subsoil
 Sub. or Subst. Substitute
 Subgr. Subgrade
 Suppts. Supports
 SUR or Sur. Survey
 Surf. Surface
 SW Southwest
 SW or Swk. Sidewalk
 Sys. or Syst. System
 Sv Sievert
 Sym. Symmetrical

T Tangent, Length Of Curve, Percent Trucks, Tesla,
 T, TWP or Twp. Township
 t Metric Ton
 tan. Tangent
 TBM Temporary Bench Mark
 TC Tangent To Curve
 TCB Temporary Concrete Barrier
 TCE Temporary Construction Easement
 TCP Terra Cotta Pipe
 TCZ Traffic Control Zone
 TDLC Transportation Design For Livable Communities
 Tel. Telephone
 Temp. Temperature or Temporary
 Theo. Theoretical
 THRMPLSTC Thermoplastic
 THW or THWN Insulation (Flame Retardant, Moisture And Heat Resistant Thermoplastic)
 Thick. Thickness
 Tk Thick, Thickness or Truck
 Tn. Ton
 Traf. Traffic
 Trans. Transition, Transverse, Translate or Transportation
 Treat. Treatment
 TS Tangent To Spiral
 TSC Length Of Tangent (Spiral Curve)
 TTC Temporary Traffic Control
 TVSS Transient Voltage Surge Suppression
 TX Transmit
 Typ. Typical

Upass. Underpass
 UG Underground
 UL Underwriters Laboratories
 Ult. Ultimate
 Unld. Unlimited
 Unddr. Underdrains
 Undrdwy. Underroadway
 UNL or Undl. Unloaded
 Untr. Untreated
 UPS Uninterruptible Power Supply
 USC & GS US Coast and Geodetic Survey (now National Geodetic Survey)
 USGS US Geological Survey
 USPS United States Postal Service
 Util. Utilities
 UV Ultraviolet

V Volt, Velocity, Volume or Hourly Volume
 Var. Varies, Variable or Variance
 VC Vertical Curve
 VCP Vitrified Clay Pipe
 VECP Value Engineering Change Proposal
 Veh. Vehicle
 Vert. Vertical
 VF Vertical Foot
 Vh Verified Horizontal Location
 VMS Variable Message Sign
 Vol. Volume
 VP Vertical Panel
 VPD or Vpd. Vehicles Per Day
 VPH or Vph. Vehicles Per Hour
 VPHPL or Vphpl. Vehicles Per Hour Per Lane
 VRMS Volts Root Mean Square
 Vv Verified Vertical Elevation
 Vvh Verified Vertical Elevation And Horizontal Location
 VW Variable Width

W Width, Wide, West or Watt
 W/C Water-Cement Ratio
 WB Westbound
 Wb. Weber
 WB40 Intermediate Semi Trailer
 WB50 Large Semi Trailer
 WB62 Interstate Semi Trailer
 WB67D Tandem Semi Trailer
 WM Water Main
 W.P.I. Work Program Item
 WT Water Table Or Weight
 WWF Welded Wire Fabric
 WWR Welded Wire Reinforcing

X Coordinate Value (East-West Direction) or Extra
 X Rd. Cross Road
 Xing. Crossing
 Xsec. Cross Section

Y Coordinate Value (North-South Direction)
 Yd. Yard
 Yr. Year

Volt, Velocity, Volume or Hourly Volume
 Varies, Variable or Variance
 Vertical Curve
 Vitrified Clay Pipe
 Value Engineering Change Proposal
 Vehicle
 Vertical
 Vertical Foot
 Verified Horizontal Location
 Variable Message Sign
 Volume
 Vertical Panel
 Vehicles Per Day
 Vehicles Per Hour
 Vehicles Per Hour Per Lane
 Volts Root Mean Square
 Verified Vertical Elevation
 Verified Vertical Elevation And Horizontal Location
 Variable Width

Width, Wide, West or Watt
 Water-Cement Ratio
 Westbound
 Weber
 Intermediate Semi Trailer
 Large Semi Trailer
 Interstate Semi Trailer
 Tandem Semi Trailer
 Water Main
 Work Program Item
 Water Table Or Weight
 Welded Wire Fabric
 Welded Wire Reinforcing

Coordinate Value (East-West Direction) or Extra
 Cross Road
 Crossing
 Cross Section

Coordinate Value (North-South Direction)
 Yard
 Year

UNITS OF MEASURE

US MEASUREMENT	
AC	Acre
AS	Assembly
BU	Bushel
CF	Cubic Foot
CD	Cleanout
CY	Cubic Yard
EA	Each
ED	Each Day
GA	Gallon
GM	Gross Mile
LB	Pound
LF	Linear Foot
LM	Lane Mile
LO	Per Location
LS	Lump Sum
LU	Luminaire
MB	Thousand Board Measure
MG	Thousand Gallons
MH	Man Hour
NM	Net Mile
PA	Per Analysis
PB	Per Building
PE	Pile
PI	Per Intersection
PL	Plant
PM	Per Mile
PS	Per Set
PW	Per Well
SI	Square Inch
SF	Square Foot
SY	Square Yard
TN	Ton











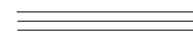





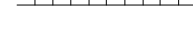
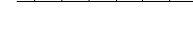

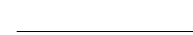

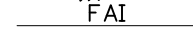

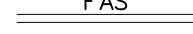
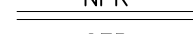
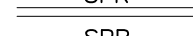
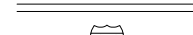
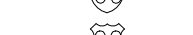

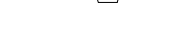
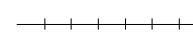

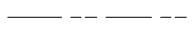
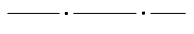

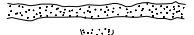





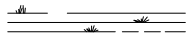



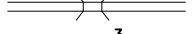
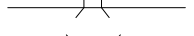
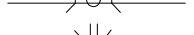



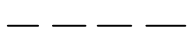
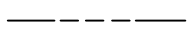



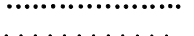
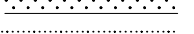
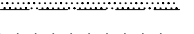
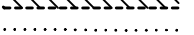
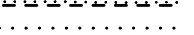
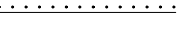





































METRIC MEASUREMENT	
AS	Assembly
CD	Cleanout
DA	Day
EA	Each
ED	Each Day
GK	Gross Kilometer
HA	Hectare
HR	Hour
KG	Kilogram
KL	Kiloliter
KM	Kilometer
LI	Liter
LK	Lane Kilometer
LO	Per Location
LS	Lump Sum
LS/AS	Lump Sum Per Assembly
LS/DA	Lump Sum Per Day
LS/EA	Lump Sum Per Each
LS/HA	Lump Sum Per Hectare
LS/KG	Lump Sum Per Kilogram
LS/LS	Lump Sum Per Lump Sum
LS/MT	Lump Sum Per Metric Ton
LS/MI	Lump Sum Per Linear Meter
LS/M2	Lump Sum Per Square Meter
LU	Luminaire
MH	Man Hour
MO	Month
MT	Metric Ton
M1	Meter
M2	Square Meter
M3	Cubic Meter
NK	Net Kilometer
PA	Per Analysis
PB	Per Building
PI	Per Intersection
PL	Plant
PW	Per Well

The abbreviations listed are the standard for contract plans production. This list is not all inclusive. Other Department accepted abbreviations may be used when deemed more appropriate. Where special abbreviations are used a descriptive tabulation may be necessary in the plans.



STANDARD ABBREVIATIONS

STANDARD SYMBOLS FOR KEY MAP

 Highway With Full Control of Access  Highway With Frontage Roads  Highway Interchange  Proposed Controlled Access Highway  Divided Highway  Hard Surfaced Road  Soil, Gravel Or Shell Surfaced Road  Graded And Drained Road  Unimproved Road  Primitive Road  Private Road  Streets In Inset Or Delimited Areas  Extension Of Local Roads Within Cities  FAI Federal Aid Interstate Highway  FAU Federal Aid Urban Highway  FAP Federal Aid Primary Highway  FAS Federal Aid Secondary Highway  NFR National Forest Road  SFR State Forest Road  SPR State Park Road  Interstate Highway  US Numbered Highway  State Highway  County Road	 Free Ferry  Toll Ferry  Canal Or Drainage Ditch  Intracoastal Waterway  Narrow Stream  Wide Stream  Dam  Dam Or Spillway With Lock  Dam With Road  Flood Control Structure  Lake, Reservoir Or Pond  Intermittent Pond  Meandered Lake  Marsh Or Swamp  Mangroves  Levee Or Dike  Levee Or Dike With Road  Highway Bridge  Small Bridges Closely Spaced  Drawbridge  Highway Grade Separation  Tunnel  State Boundary Line  County Boundary Line  Civil Township Boundary  Extended Township Line  Land Grant Line  Land Section Line  State Survey Section Line  Survey By Others  Location Of Inset Boundary Within Map  Military Reservation Boundary  College Or University Boundary  Corporate Limits  Delimited Area, Population Est.  Reservation, Forest Or Park Boundary  Wildlife Refuge Boundary	 Residential Area Under Development  Lighthouse  State Capital  County Seat  Other City Or Village  Seminole Indian Village  Welcome Station  Wayside Park Or Small Park  Park With Boat Ramp  Boat Ramp  Museum  Recreational Area Or Historic Site  Scenic Site  Post Office  School  Church  Cemetery  Church And Cemetery  Hospital, Health Center Or Rest Home  Toll House, Port Of Entry Or Weight Station  Fair Grounds, Race Course Or Rodeo Arena  Mine Or Strip Mine  Governmental Research Station  Agricultural Inspection Station  Farmers Market  Game Preserve  Game Checking Station  Bird Sanctuary  Fire Control Headquarters  Lookout Tower  Fire Station  Patrol Or Police Station  Correctional Institution Or Road Camp  DOT Department of Transportation Facility  Coast Guard Station  Armory  Junkyard  Sanitary Fill  Sewage Disposal Plant  Incinerator  Power Plant  Power Substation  Communications Facility  Locked Gate Or Fence  WOOD Triangulation Station
---	---	---

GENERAL NOTE

1. Symbols on this Index are intended for use on all Roadway, Signing And Marking, Signalization, and Lighting projects. For work zone traffic control symbols refer to Index 600. When additional or similar symbols are used, legends or notations may be required for clarity.



STANDARD SYMBOLS FOR PLAN SHEETS

GENERAL SYMBOLS

	State Line
	County Line
	Township Line
	Section Line
	City Line
	Base Or Survey Line
	Right-Of-Way
	Easement Line
	Limited Access Line
	Fence Line
	National Or State Park Or Forest
	Grant Line
	Railroad (Drainage Maps)
	Railroad (Detail Plans)
	Fence (Limited Access)
	Box Culvert
	Bridge
	Pipe Culvert-Mitered End Section
	Pipe Culvert-Straight Endwall
	Pipe Culvert-U-Type Endwall
	Pipe Culvert-Median Drain
	Pipe Culvert-Other End Treatments
	18" SD Storm Drain (Proposed)
	18" SD Storm Drain (Existing)
	Inlet
	Manhole
	Tied Longitudinal Joint
	Keyed Longitudinal Joint
	Doweled Transverse Expansion Joint
	Doweled Transverse Contraction Joint
	Transverse Contraction Joint Without Dowels
	Survey Reference Point
	ALACHUA Triangulation Station
	B.M. NO. 112 Bench Mark
	Point Of Intersection
	North Arrow
	Edges Of Existing Pavement And Sidewalk
	Guardrail
	C. C. Crash Cushion (Attenuator)
	Piling Pier Column
	Concrete Monument
	Base Line
	Centerline
	Flow Line
	Property Line
	Delta Angle
	Approximate
	Round Or Diameter

	Curb
	Curb And Gutter
	Water Well, Spring
	Levee
	MP 327 Railroad Mile Post
	Railroad Signal With Gate
	Railroad Switch
	Gate
	Pump Island
	Storage Tank (Surface)
	Storage Tank (Underground)
	Mine Or Quarry
	Borrow Pit
	Church
	Store
	RES Residence
	B Barn
	S School
	Synthetic Bales
	Silt Fence
	Floating Turbidity Barrier
	Staked Turbidity Barrier
	Stream
	Shore Line
	Marsh
	Wetland Boundary (Proposed)
	Wetland Boundary (Existing)
	Hedge
	Trees
	Edge Of Wooded Area
	Shrubbery
	Grove Or Orchard
	Lt. Skew Rt. Definition Of Skew For Cross Drains And Barrels Of Concrete Box Culverts
	Rt. Skew Lt.
	Concrete
	Wood
	e Rate Of Superelevation

UTILITY ADJUSTMENT SYMBOLS

EXISTING	PROPOSED	EXISTING	PROPOSED
		W - - - - 6" - - - - W	W W W W W 6" M M M M M M M Water Main
		NPW - - - - 6" - - - - M M N	NPW NPW 6" M M N M M N Non Potable Water
		S - - - - 8" - - - - S	S S S S S 8" S S S S S Sanitary Sewer
		G - - - - 6" - - - - G	G G G G G 6" G G G G G Gas
		RD - - - - 4" - - - - RD	RD RD RD 4" RD RD RD Roof Drain
		PET - - - - 8" - - - - PET	PET PET 8" PET PET Petroleum
		STM - - - - 12" - - - - STM	STM STM 12" STM STM Steam
		CAS - - - - 12" - - - - CAS	CAS CAS 12" CAS CAS Casing
		DT - - - - 4"x4" - - - - DT	DT DT 4"x4" DT DT Duct
		BE - - (7.5 kV) - - - - BE	BE BE (7.5 kV) BE BE Buried Electric
		OE - - (7.5 kV) - - - - OE	OE OE (7.5 kV) OE OE Overhead Electric
		BTV - - - - 3" - - - - BTV	BTV BTV 3" BTV BTV Buried Cable Television
		OTV - - - - 2" - - - - OTV	OTV OTV 2" OTV OTV Overhead Cable Television
		BT - - - - 2" - - - - BT	BT BT 2" BT BT Buried Telephone
		OT - - - - 2" - - - - OT	OT OT 2" OT OT Overhead Telephone
		BFO - - - - 2" - - - - BFO	BFO BFO 2" BFO BFO Buried Fiber Optic
		OFO - - - - 1" - - - - OFO	OFO OFO 1" OFO OFO Overhead Fiber Optic

See General Note, Sheet 1 of 3



STANDARD SYMBOLS FOR PLAN SHEETS

TRAFFIC SIGNALS SYMBOLS

EXISTING	PROPOSED	
		Traffic Signal Head (Span Wire Mounted)
		Traffic Signal Head (Pedestal Mounted)
		Traffic Signal Head (Mast Arm Mounted)
		Traffic Signal Pole (Concrete, Wood, Metal)
		Vehicle Detector (Loop)
		Signal Cable (On Messenger Wire)
		Conduit
		Vehicle Detector (Points)
		Pedestrian Detector
		Pedestrian Signal Head (Pole Or Pedestal Mounted)
		Controller Cabinet (Base Mounted)
		Controller Cabinet (Pole Mounted)
		Walk - Dont Walk
		Flashing Dont Walk
		Signal Face Number
		Signal Lens
		Programmed Signal Head
		Messenger Wire
		Pole Tabulation Cross Reference
		Pole Tabulation Cross Reference (Joint Use Pole)
		Signal Phase

LIGHTING SYMBOLS

EXISTING	PROPOSED	
		Pole & Luminaire
		Existing Pole & Luminaire To Be Removed
		Final Position Of Relocated Or Adjusted Pole & Luminaire
		High Mast Lighting Tower
		City Or Utility Owned Luminaire & Pole
		PVC (Polyvinyl Chloride) Lighting Conduit And Conductors
		Rigid Galvanized Lighting Conduit And Conductors
		Lighting Pull-Box
		Light Distribution Point
		Joint Use Pole
		Pier Cap Underdeck Luminaire
		Pendant Hung Underdeck Luminaire

SIGNING AND PAVEMENT MARKING SYMBOLS

	Pavement Arrow
	Single Solid Line
	Double Solid Line
	Skip Line
	Stop Bar
	Traffic Sign (Post Mounted)
	Traffic Sign (Overhead)
	Sign Number
	Sign Item Number
	Traffic Flow Arrow

See General Note, Sheet 1 of 3



2010 FDOT Design Standards

STANDARD SYMBOLS

Last Revision 07/01/05	Sheet No. 3 of 3
Index No. 002	

NOTES:

1. Barrier wall or bridge mounted poles: The wiring shall be in accordance with Section 992 of the Standard Specifications.

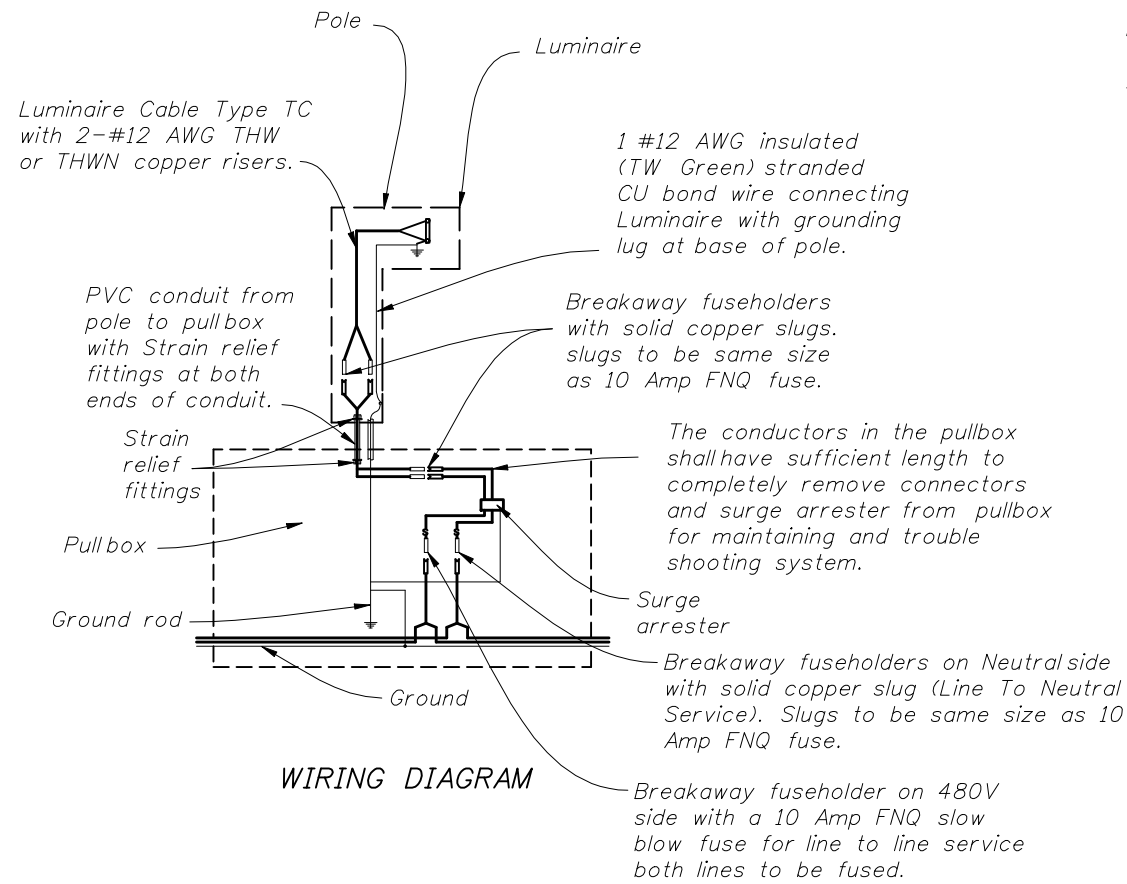

WIRING DIAGRAM

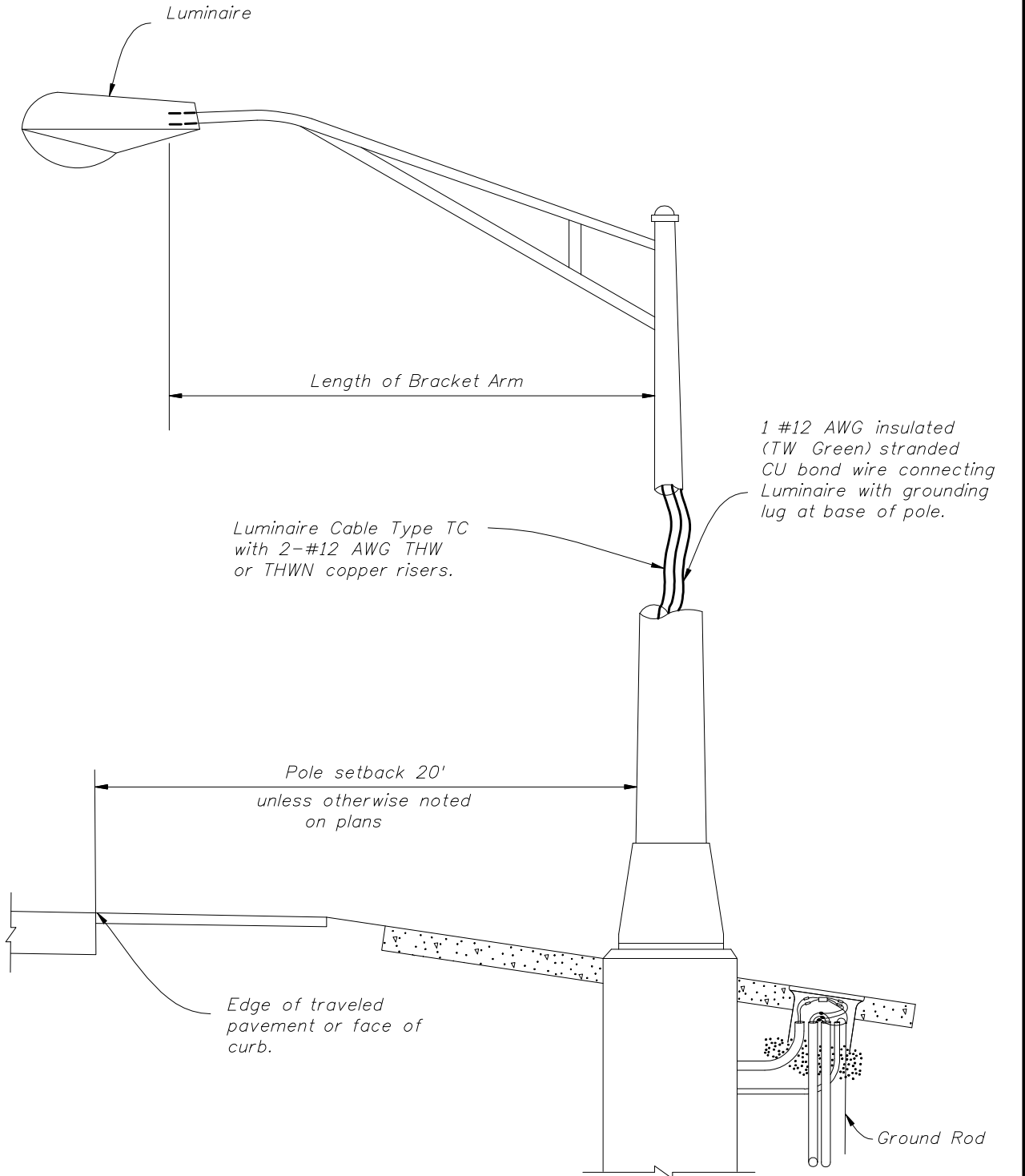

METAL POLE DETAIL

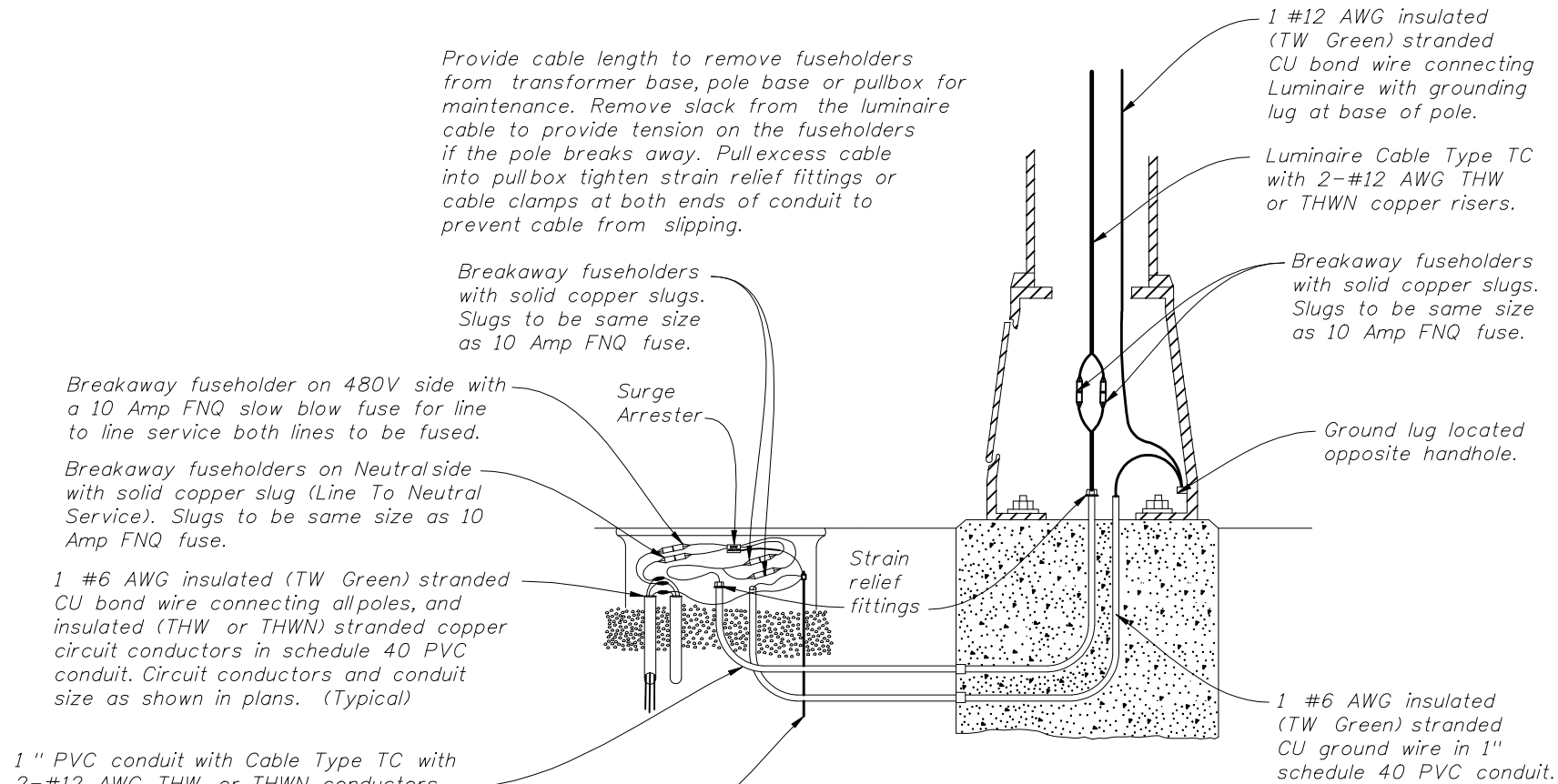

METAL POLE WIRING DETAIL

U.L. approved Ground Rod $\frac{5}{8}$ " diameter 20' long copper clad with approved ground connection (At all pull boxes)

WIRING DETAILS



2010 FDOT Design Standards

CONVENTIONAL LIGHTING

Last Revision 07/01/09 Sheet No. 1 of 3

Index No. 17500

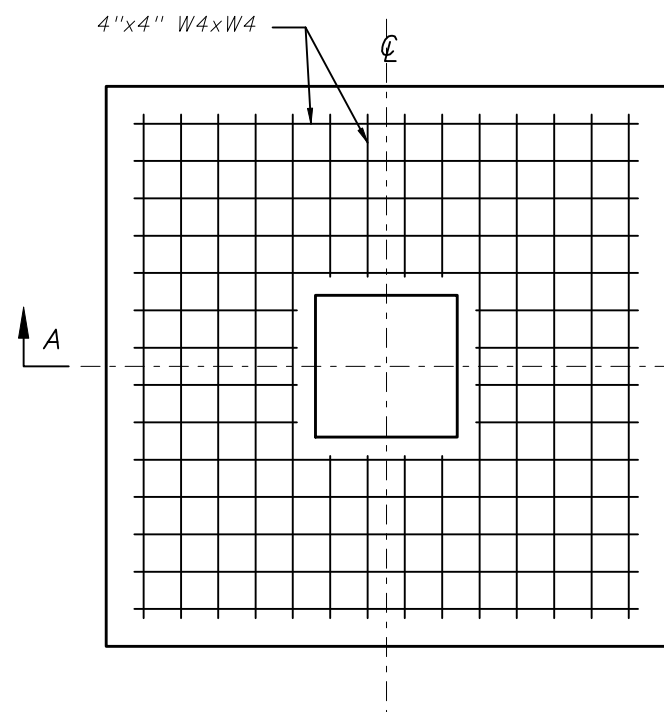

REINFORCEMENT LAYOUT

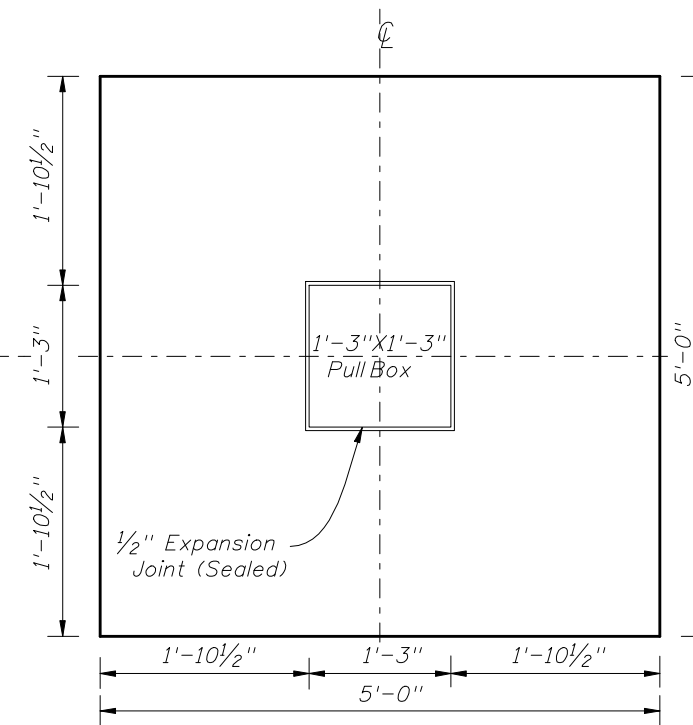

SLAB DIMENSIONS

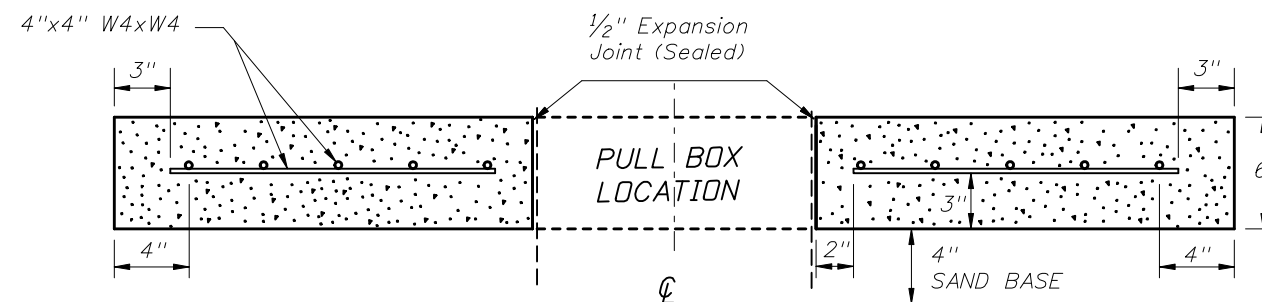

SECTION A-A

NOTES:

1. Use clean free draining sand less than 5% passing No. 200 sieve for base (4").
2. Welded wire fabric shall meet the requirements of ASTM A185.
3. Concrete shall be Class NS with a minimum strength at 28 days of $f'c=2.5$ ksi.
4. Outside edges of slab shall be cast against formwork.
5. The pull box shown is 1'-3" x 1'-3"; others approved under Section 635 of the Standard Specifications may be used.
6. Slabs to be placed around all Poles and Pull Boxes in rural allocations. In urban areas or where space is limited slab dimensions may be adjusted as shown in the plans.
7. Concrete and reinforcing for slabs around poles and pull boxes shall be included in the price for pull box or pole.
8. The 1/2" thick expansion joint between the pole shaft and slab and the pull box and slab shall be sealed with a hot poured elastic joint sealer.

SLAB DETAILS FOR INTERMEDIATE PULLBOX LOCATIONS



2010 FDOT Design Standards

CONVENTIONAL LIGHTING

Last Revision	Sheet No.
07/01/09	2 of 3
Index No.	
17500	

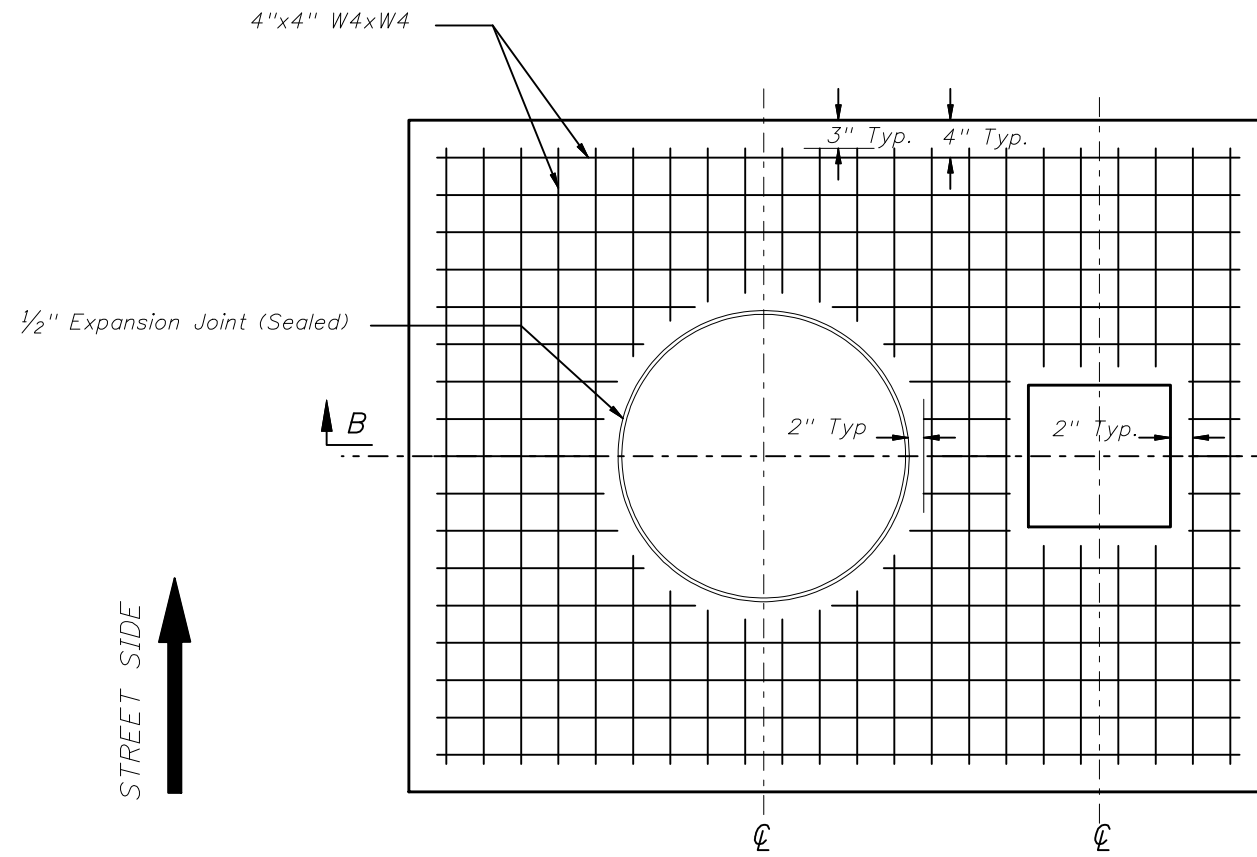

REINFORCEMENT LAYOUT

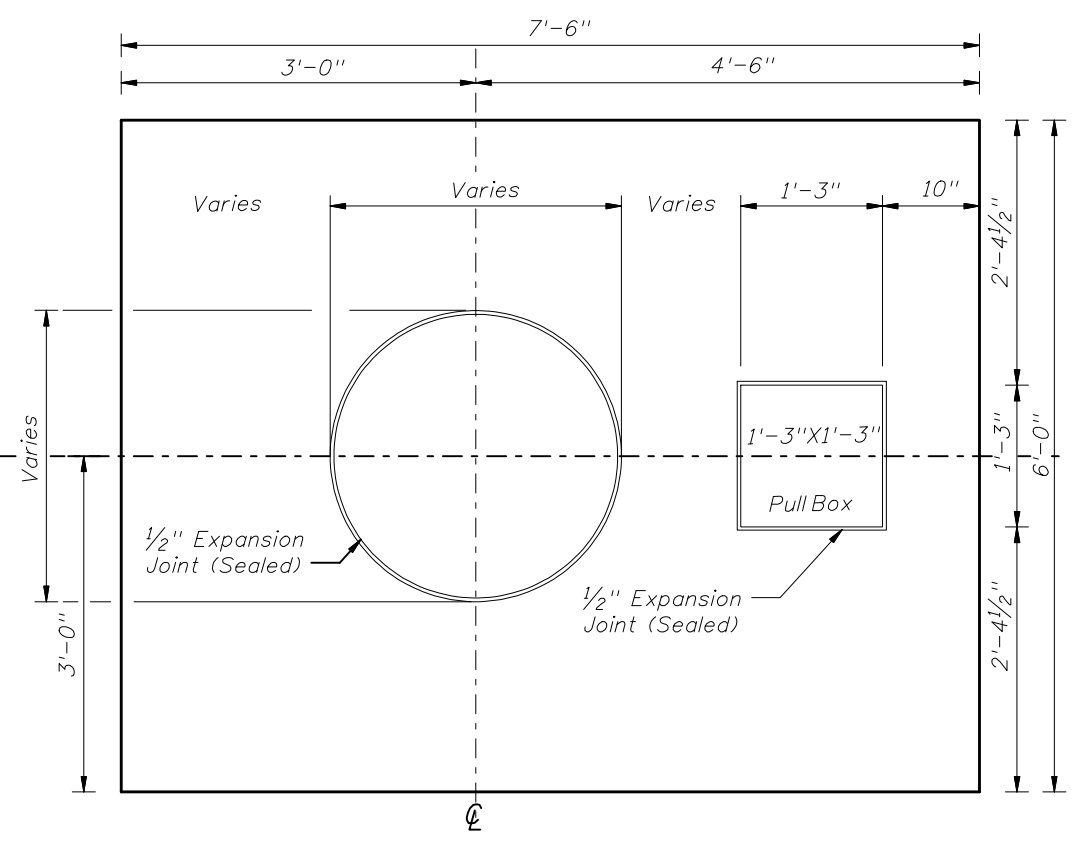

SLAB DIMENSIONS

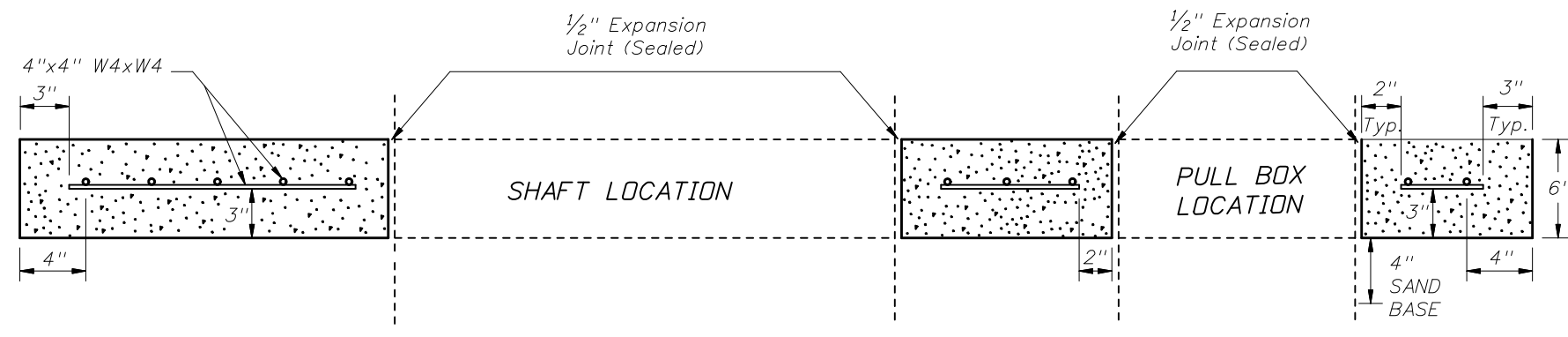

SECTION B-B

NOTES:

1. Use clean free draining sand less than 5% passing No. 200 sieve for base (4").
2. Welded wire fabric shall meet the requirements of ASTM A185.
3. Concrete shall be Class NS with a minimum strength at 28 days of $f'c=2.5$ ksi.
4. Outside edges of slab shall be cast against formwork.
5. The pullbox shown is 1'-3" x 1'-3"; others approved under Section 635 of the Standard Specifications may be used.
6. Slabs to be placed around all Poles and PullBoxes in rural allocations. In urban areas or where space is limited slab dimensions may be adjusted as shown in the plans.
7. Concrete and reinforcing for slabs around poles and pullboxes shall be included in the price for pullbox or pole.
8. The 1/2" thick expansion joint between the pole shaft and slab and the pull box and slab shall be sealed with a hot poured elastic joint sealer.

SLAB DETAILS FOR POLE AND PULL BOX LOCATIONS



- 1) All grounding system connections shall be exothermically welded. This includes all cables, ground electrode and arrays. Do not exothermically bond grounding electrode to grounding electrode. Method of Measurement and Basis of Payment as per Section 620 of the Standard Specifications.
- 2) The contractor shall be responsible for contacting all utility companies prior to any underground work. The utility company will locate and identify their facilities.
- 3) Contractor shall determine the service required date for the power company transformer installation at the pre-construction conference.
- 4) The power company reserves the right to install the riser, switch gear and weatherhead on power company poles at the expense of the contractor. Contact the power company for cost or for authorization for an alternate procedure.
- 5) Any damaged portions of galvanized steel poles and bracket arms shall be painted in accordance with Section 562 of the Standard Specifications.
- 6) Poles and bracket arms shall be designed in accordance with the design criteria, as indicated in the plans and using the applicable equations found in the AASHTO 'Standard Specifications For Structural Supports For Highway Signs, Luminaires And Traffic Signals' and FDOT Structures Manual. The calculations shall be based on the actual projected area of the luminaire or 3.0 square feet whichever is greater.
- 7) The luminaire manufacturer shall place a permanent tag on the luminaire housing on which is imprinted the following information : Wattage, ballast type, lamp shown on design plans, lamp setting (position of luminaire), IES light distribution with this lamp in the position specified, input voltage and power factor. Luminaire photometric submittals required.
- 8) Before final acceptance, contractor shall provide 2 sets of full size as built plans to the maintaining agency.
- 9) Conduit routing shall be pole to pole, maintaining pole setback distance from edge of pavement. Any cable routing in locations where guardrail is proposed shall be 2' in front of the standard guardrail position.
- 10) Pole positions and conduit routing may be adjusted, as approved by the Engineer, to prevent conflicts with utility and drainage structures not indicated, and prevent guardrail post conflict with underground lighting circuits.
- 11) Where guardrail is constructed, the poles shall be placed a minimum of 4' behind the face of the guardrail.
- 12) Install pole foundations in accordance with Section 715 of the Standard Specifications.
- 13) All splices shall be made in pullboxes or the pole base. No splices shall be made inside the conduit. The wires at pullboxes shall have sufficient length to completely remove connectors to the outside of pullboxes remove connectors to the outside of pullboxes to make connectors accessible for changing fuses and trouble shooting the system.

- 14) Neutral wires to have white insulation. Do not use white or green insulated wires for ungrounded conductors.
- 15) Unless otherwise specified, all cable shall be single conductor, 98 percent conductivity stranded copper, with THW or THWN insulation.
- 16) All exposed or surfaced mounted conduit shall be rigid or intermediate metal. These exposed runs of conduit shall be provided with either expansion joints or flexible metal conduit sections adequate to take care of vibrations and thermal expansions. All metal conduit shall be grounded. Steel conduit shall be hot-dipped galvanized.
- 17) All conduit that will remain empty as spares shall be mandrel tested, cleaned inside and both ends capped. Leave the corrosion resistant pull/drag wire and place pullboxes to mark the location of the ends of the conduits.
- 18) Pullboxes shall be located at ends of conduit crossing roadways, and as necessary for the completion of the project.
- 19) These plans represent minimum acceptable criteria. The inspection per these drawings represent the minimum base of acceptance.
- 20) All material, unless otherwise specified, shall be Underwriters Laboratory approved.
- 21) Pullboxes shall meet the requirements of Section 635 of the 'Standard Specifications For Road And Bridge Construction' and Section 635 of the 'Minimum Specifications For Traffic Control Signals And Devices'.
- 22) A pullbox shall be installed at each pole location. Pullboxes should be located 2' max from pole unless otherwise directed by the project engineer. Metal pullbox covers shall be grounded. See General Requirements Section 635-5 of the Standard Specifications for Road and Bridge Construction.
- 23) At all pullboxes and pole bases, ends of conduit shall be sealed in accordance with Section 630 of the Standard Specifications for Road and Bridge Construction.
- 24) Luminaire shall be supplied with a regulator type ballast mounted on a hinged door or panel. The unit shall swing open to provide access to the ballast assembly by release of captive screws. The electrical connector shall be a quick disconnect plug. The unit shall be easily removed from the luminaire after release of captive screws and disconnect plug.
- 25) All mounting heights are \pm 2'-6" unless otherwise noted in plans.
- 26) A handhole is required in all poles. Handhole should be located opposite approaching traffic with cover fastened with Stainless Steel Screws. The handhole opening shall be at least 20 square inches.
- 27) The luminaire and arm on joint use poles shall be grounded.

BREAKAWAY FEATURE

All conventional mounting height poles shall be mounted on a frangible metal base. The base shall be one piece and be designed to breakaway without the aid of any slipping or sliding surfaces. The design of the breakaway feature shall be in accordance with the breakaway performance requirements of the AASHTO 'Standard Specifications For Structural Supports For Highway Signs, Luminaires and Traffic Signals'. The contractor (supplier) shall submit copies of test reports as evidence the breakaway feature meets the above specifications and calculations to verify the design will meet the AASHTO wind loading specified in the contract plans. No poles are to be installed prior to approval of submittal data.

Any substantial remains of a breakaway support, when it is broken away, should not project more than 4" as discussed in Section 7 of the above AASHTO Specifications, and, Chapter 4, Section 4.2 of the AASHTO 'Roadside Design Guide'.

Poles behind bridge rail or barrier wall mounted, shall be non-frangible.

SURGE PROTECTOR SPECIFICATIONS

1. The unit shall withstand a surge current up to 20,000 Amps, and repetitive surges of 200 Amps for a minimum of 10,000 occurrences.
2. The unit shall respond in less than 50 nanoseconds and within this time have a peak clamping voltage better than 1,100 Vrms.
3. The maximum allowable voltage that can pass continuously through the hot leg of the protector must be less than 550 Vrms.
4. The current drain shall be less than 100 microamps.
5. The unit shall be insulated 600 V to ground and shall be weatherproof.
6. The unit shall not allow holdover current or conduction to ground after the surge ends.
7. Protection shall be achieved for both the 480 V and neutral conductors with the surges being passed to ground and NDT to neutral.
8. There shall be no discharge lag in the protection of the 480 V conductor over the neutral conductor.
9. Underwriters Laboratory approval not required.



2010 FDOT Design Standards

HIGHWAY LIGHTING GENERAL NOTES

Last Revision	Sheet No.
07/01/09	1 of 1
Index No.	
17501	

LOWERING SYSTEM SPECIFICATIONS

The lowering system shall consist of the following:

- A. Head frame and cover
- B. Luminaire ring
- C. Cables
- D. Winch
- E. Portable power unit (1 per project)

The head frame unit shall rigidly mate the top of the pole to the head frame platform. The platform with its associated sheaves, etc. shall be covered and raintight. The head frame structure shall be zinc coated steel, attached to the pole by means of a steel slipfitter. Head frame shall encompass six 6" nominal steel cable sheaves grooved to the exact cable diameter, for 180° cable bearing surface. The sheave shall be zinc electroplated to ASTM 164 and dipped in yellow chromate for corrosion resistance. Bearings and cable keepers shall have permanent lubrication. Three (3) stainless steel 7 x 19 aircraft cables of 3/16" or greater diameter shall be provided.

The pole cable shall be attached to the luminaire ring with a waterproof connector capable of withstanding the pull of the weight of the pole cable. Where the wire ropes are required to bend over sheaves or over the winch drum, the maximum working stress in the outer fibers of wire rope shall not exceed 20% of the wire rope manufacturer's rated ultimate stress.

Drum design shall cause level wind of wire rope. The power cord shall travel on sheave (s) or a combination of rollers providing a radius for the cord of 6" or larger. Each end of the sheave (s) or rollers shall have a keeper to prevent the cable from jumping out of the roller track.

The head frame shall also include three (3) latching devices to support the luminaire ring assembly when the lowering device is not in operation. The latches shall be actuated by alternate raising and lowering of the hoisting cables. Locking of luminaire ring shall be signaled by indicators visible from ground. All moving parts of the latch mechanism shall be serviceable from the ground. Each of the three latches shall be strong enough, by itself, to support twice the weight of the ring and all the luminaires. Latching mechanisms which depend primarily upon spring operation or contain dissimilar metals are not acceptable. The latching mechanism shall not require adjustment after the original installation.

The luminaire ring shall be constructed of a minimum of 6" x 2" x 7 gauge steel channel galvanized in accordance with ASTM A123 Class "B" steel channel with the appropriate number of 2" steel pipe mounting arms. The luminaire ring shall be prewired with Type "W" or specially reinforced Type "SD" power cable with suitable conductor quantity and size for proper operation and Type "ST" distribution wiring with insulation suitable for at least 105°C. All power cables should be attached to the aluminum weathertight wiring chamber with weathertight cable connectors. A 600 volt terminal block, completely prewired shall be included in the weathertight wiring chamber. A weather-tight twistlock power inlet shall be provided on the luminaire ring to allow testing of the luminaire while in the lowered position. The power inlet shall face away from the pole for easy access. Raising speed of the luminaire ring shall be a minimum of 12' per minute.

The ultimate support of the luminaire ring shall not be dependent upon the lowering and raising cables.

The system shall be provided with a circuit breaker assembly with a lightning arrester on the circuit breaker enclosure. A pigtail cord and receptacle shall be supplied from the circuit breaker assembly. The receptacle on the pigtail cord shall be of dead front construction. The receptacle shall have a push button pawl which screws the plug to the receptacle and when secure shall provide a NEMA 3R rating. The plug and receptacle shall be UL/CSA switch rated.

The winch shall be a reversible worm gear self locking type with an integral friction drag brake to prevent freespooling. The winch shall be designated for hand operation or for operation by means of a 1/2" heavy duty reversing electric drill motor, remote controlled to enable the operator to stand 25' from the pole, Stainless Steel 7 x 19 aircraft cables of 1/4" or greater diameter equal to MIL-W83420C shall be supplied on the winch. The winch shall be provided with keepers above the drum to force the cable away from the ends of the drum for spooling. The drum shall have a wire guard to prevent the cable from coming off.

The winch shall be mounted in such a way that the cable terminator and the riser cable connector may be reached and worked on by a person with his arm through the handhole.

Roller contact spring-loaded centering arms shall be provided to center the luminaire ring while ascending or descending the pole. The rollers for the centering arm shall be made of a water resistant nonmarking composition material. All axle shafts for arms and rollers shall be 304 stainless steel. The rollers shall be in contact with the pole at all times. The centering arms shall be interconnected and loaded with stainless steel springs to uniformly apply equal centering force from the arms.

LUMINAIRE SPECIFICATIONS

The reflector with its aluminum cover shall be firmly attached to a cast ring. This ring shall have keyhole slots in its upper surface such that the reflector/refractor assembly may be readily attached to, or detached from, the luminaire bracket entry and lamp support assembly without completely removing the support bolts.

Each luminaire shall contain an integral auto-regulator type ballast connected for 480 volts input + 10% and a power factor of more than 90%. The luminaire ballast shall be enclosed within an aluminum housing which integrally attaches to the luminaire bracket entry and lamp support assembly. It shall be readily removable without removing the luminaire from the bracket arm.

The luminaire shall be attached to the bracket arm by means of a bracket entry and lamp support assembly. The assembly shall include a side entry slipfitter designed for 2" pipe with provision for 3° adjustment for leveling the luminaire. An enclosed terminal block shall be included such that all electrical connections shall be protected from exposure to weather.

All electrical connections shall be made waterproof or be made inside a weather resistant enclosure. All luminaires shall be ANSI/IES light distribution as indicated in plans. Each luminaire shall be labeled with a permanent label which states the type of lamp, voltage input, power input, power factor, ballast type, socket position, ANSI/IES light distribution, and such other catalog information that a complete replacement can be readily ordered.

The contractor's attention is directed to those plan sheets detailing the mounting of luminaires at the pole top. Particular attention is directed to alignment of luminaire light distributions. Special attention must be exercised in the physical alignment of these luminaires to ensure that the approved photometric layout is physically produced at each lighting standard in the field. A marking shall be placed on the external face of the refractor to allow visual inspection of alignment. The marking shall correspond to the 0° axis of the refractor.

LOWERING SYSTEM AND LUMINAIRE SPECIFICATIONS



2010 FDOT Design Standards	
HIGHMAST LIGHTING	

Last Revision 07/01/07	Sheet No. 1 of 7
Index No. 17502	

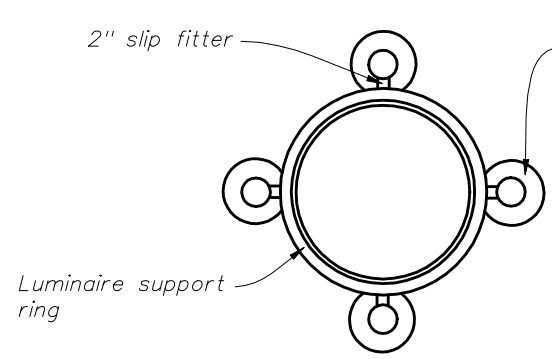

See legend for number of luminaires, lamp wattage and light distribution.

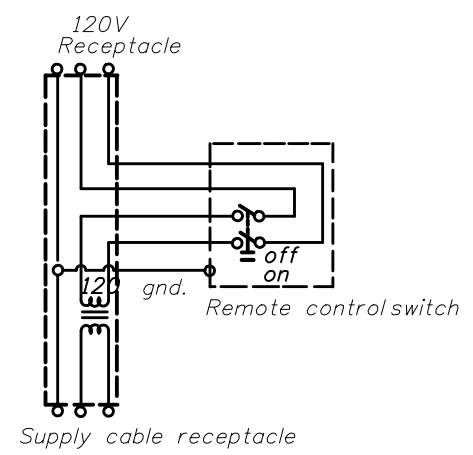
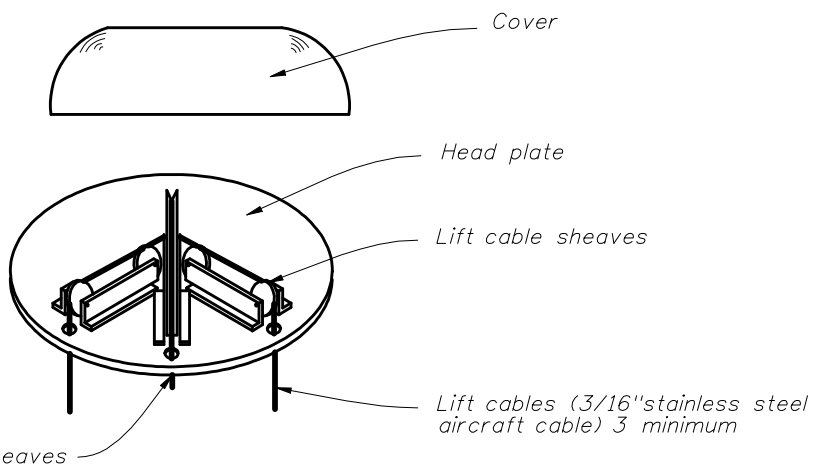

SCHEMATIC OF REMOTE AUXILIARY POWER UNIT

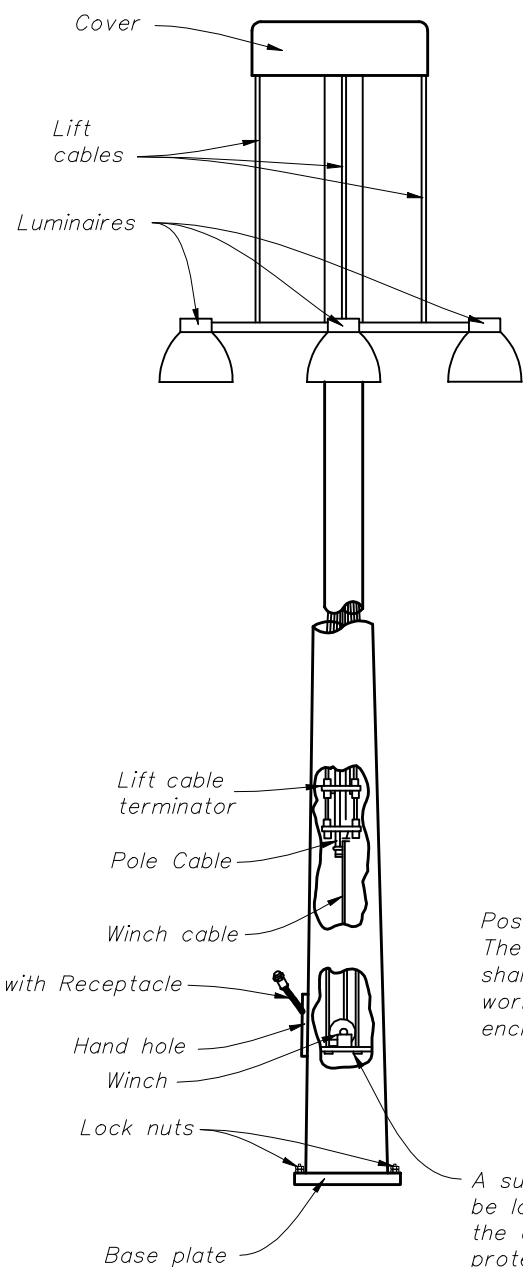

Spring supported centering arms provided to center the luminaire ring.

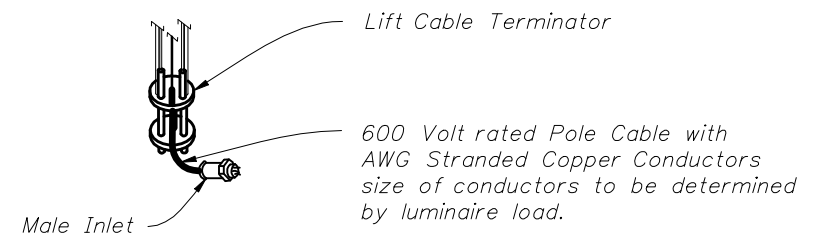

600 Volt rated Pole Cable with AWG Stranded Copper Conductors size of conductors to be determined by luminaire load.

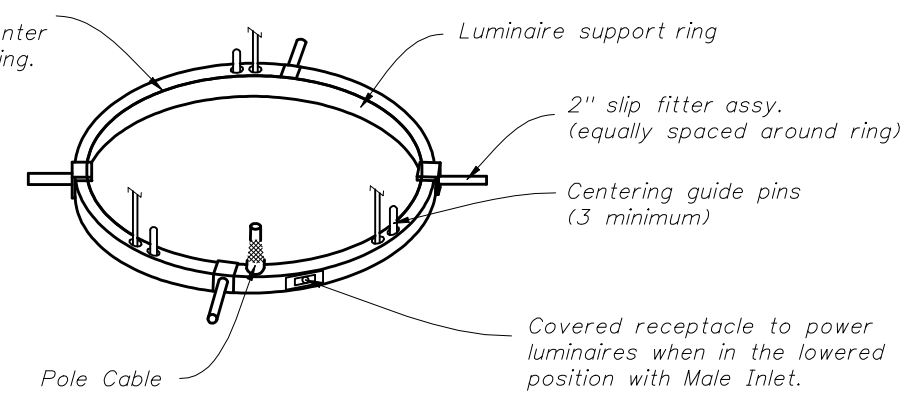

5/8" hex drive 3/4" round shaft

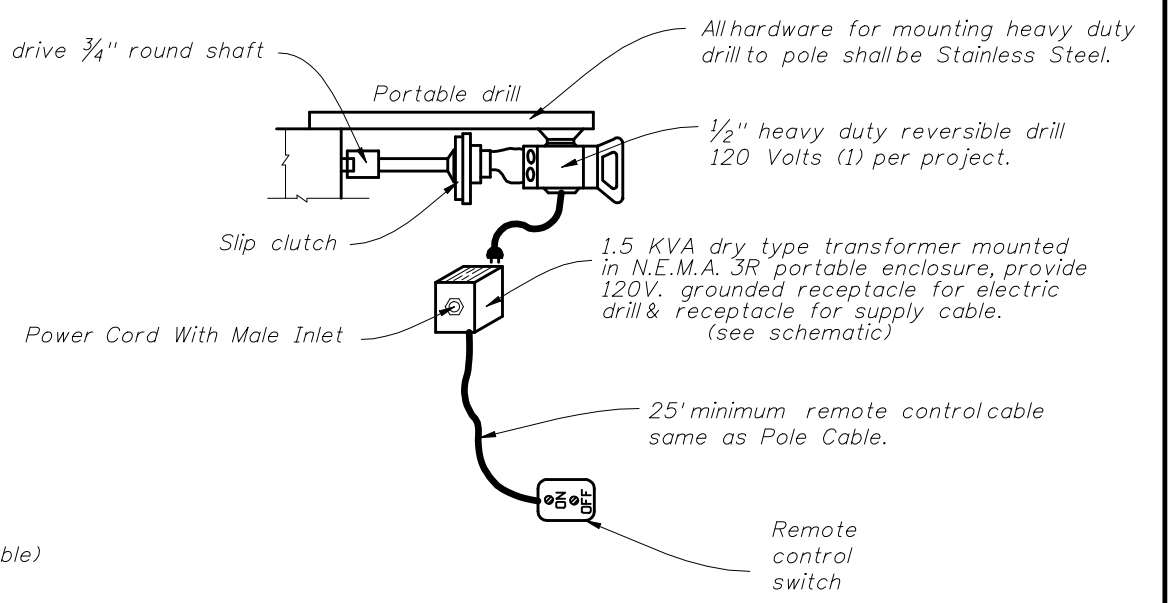

High mast pole

Positive drive reversible winch. The complete enclosed drum gear shall directly mesh with the worm gear train, in the same enclosure.

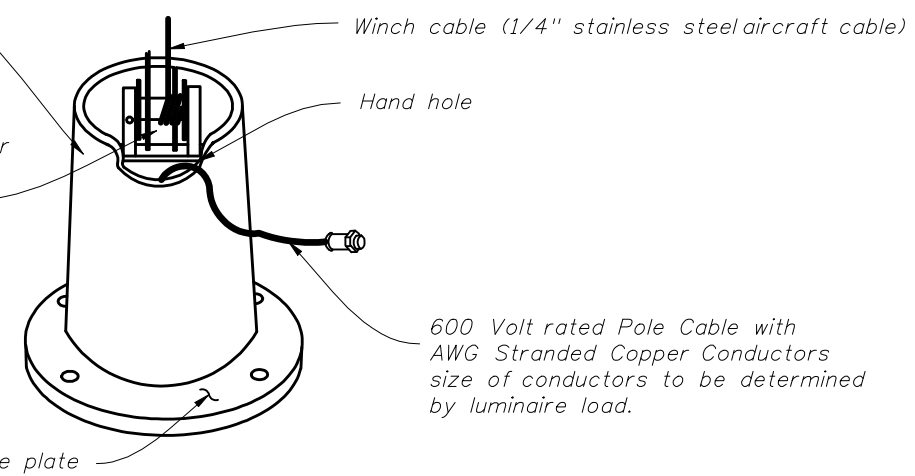

600 Volt rated Pole Cable with AWG Stranded Copper Conductors size of conductors to be determined by luminaire load.

A surge protector shall be located in the pole with the circuit breaker. The surge protector shall be mounted at the front near hand hole for easy access.

LOWERING DETAILS

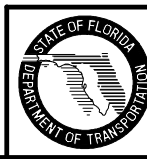

2010 FDOT Design Standards

HIGHMAST LIGHTING

Last Revision	Sheet No.
07/01/07	2 of 7
Index No.	
17502	

HIGHMAST LIGHTING NOTES:

- 1) High Mast materials:
 - a. Pole: ASTM A1011 Grade 50, 55, 60 or 65 (Less than 1/4") or ASTM A572 Grade 50, 55, 60, or 65 (1/4" and over) or ASTM A595 Grade A (55 ksi yield) or Grade B (60 ksi yield).
 - b. Steel Plates: ASTM A709 Grade 36 or ASTM A36
 - c. Weld Metal: E70XX
 - d. Anchor Bolts: ASTM F1554 Grade 55 with ASTM A563, Grade A heavy-hex nuts and ASTM F436 Type I washers.
 - e. Handhole: ASTM A709 Grade 36 or ASTM A36 Frame with ASTM A36 cover.
 - f. Caps: ASTM A1011 Grade 50, 55, 60 or 65 or ASTM B209.
 - g. Nut Covers: ASTM B26 (319-F)
 - h. Stainless Steel Screws: AISI Type 316
- 2) Reinforcing steel: ASTM A615, Grade 60.
- 3) Concrete: Class IV (Drilled Shaft) with a minimum 4,000 psi compressive strength at 28 days for all environmental classifications.
- 4) Welding: American Welding Society Structural Welding Code (Steel) ANSI/AWS D1.1 (Current edition).
- 5) Galvanization:
 - a. Nuts, Bolts, Washers and Threaded Bars/Studs: ASTM F2329.
 - b. Other items (Including Pole): ASTM A123
- 6) Hole diameters for anchor bolts: not greater than the bolt diameter plus 1/2".
- 7) Poles: Tapered with the diameter changing at a rate of 0.14 inch per foot with a minimum 16-sided pole shaft and only one longitudinal seam weld. Circumferentially welded pole shaft butt splices and laminated pole shafts are not permitted. Longitudinal seam welds within 6 inches of pole to base must be complete penetration welds. Longitudinal seam welds at telescopic field joints must be complete penetration welds for the splice length plus 6 inches.
- 8) One hundred percent of full-penetration groove welds and a random 25 percent of partial penetration groove welds shall be inspected. Full-penetration groove weld inspection shall be performed by nondestructive methods of radiography or ultrasonics.
- 9) Furnish each pole with a 2"x4" (max.) aluminum identification tag. Submit details for approval. Secure to pole with 0.124" stainless steel rivets or screws. Locate identification tag on the inside of pole and visible from handhole. Include the following information: Financial Project ID, Pole Mounting Height, Manufacturer's Name, Certification Number and QPL Number.
- 10) Manufacturers seeking approval of a Highmast Lighting structural assembly (exclude lowering system) for inclusion on the Qualified Products List must submit a QPL Production Evaluation Application along with drawings showing the product meets all specified requirements of this Index.
- 11) Verify CSL access tubes will not interfere with anchor bolt installation before excavating the shaft. When CSL access tube locations conflict with anchor bolt locations, move the CSL access tube location ± two inches along the inner circumference of the reinforcing cage. Notify the Engineer before excavating the shaft if the CSL access tube locations cannot be moved out of conflict with anchor bolt locations.

DESIGN CRITERIA:

- 1) Designed in accordance with the FDOT Structures Manual.
- 2) Poles are designed to support the following:
 - a. (1) cylindrical head assembly with a maximum effective projected area of 6 Sq. ft. (Cd=1) and 340 lbs (Max).
 - b. (8) cylindrical luminaires with a maximum effective projected area of 3.0 Sq. ft (Cd=0.5) and 77 lbs. each.
- 3). Foundation design based upon the following soil criteria:
 - Classification = Cohesionless (Fine Sand)
 - Friction Angle = 30 Degrees (30°)
 - Unit Weight = 50 lbs./cu. Ft. (assumed saturated)

Only in cases where the Designer considers the soil types at the specific site location to be of lesser strength properties should an analysis be required. Auger borings, SPT borings or CPT soundings may be utilized as needed to verify the assumed soil properties, and at relatively uniform sites, a single boring or sounding may cover several foundations. Furthermore, borings in the area that were performed for other purposes may be used to confirm the assumed soil properties.
- 4) Foundation applies only to slopes of 1:4 or flatter. Provide a minimum 24" shaft projection on the high side.
- 5) Poles are designed for 6 mil galvanization thickness.

STANDARD POLE DESIGN NOTES

	2010 FDOT Design Standards	Last Revision 01/01/09	Sheet No. 3 of 7
	HIGHMAST LIGHTING		Index No. 17502

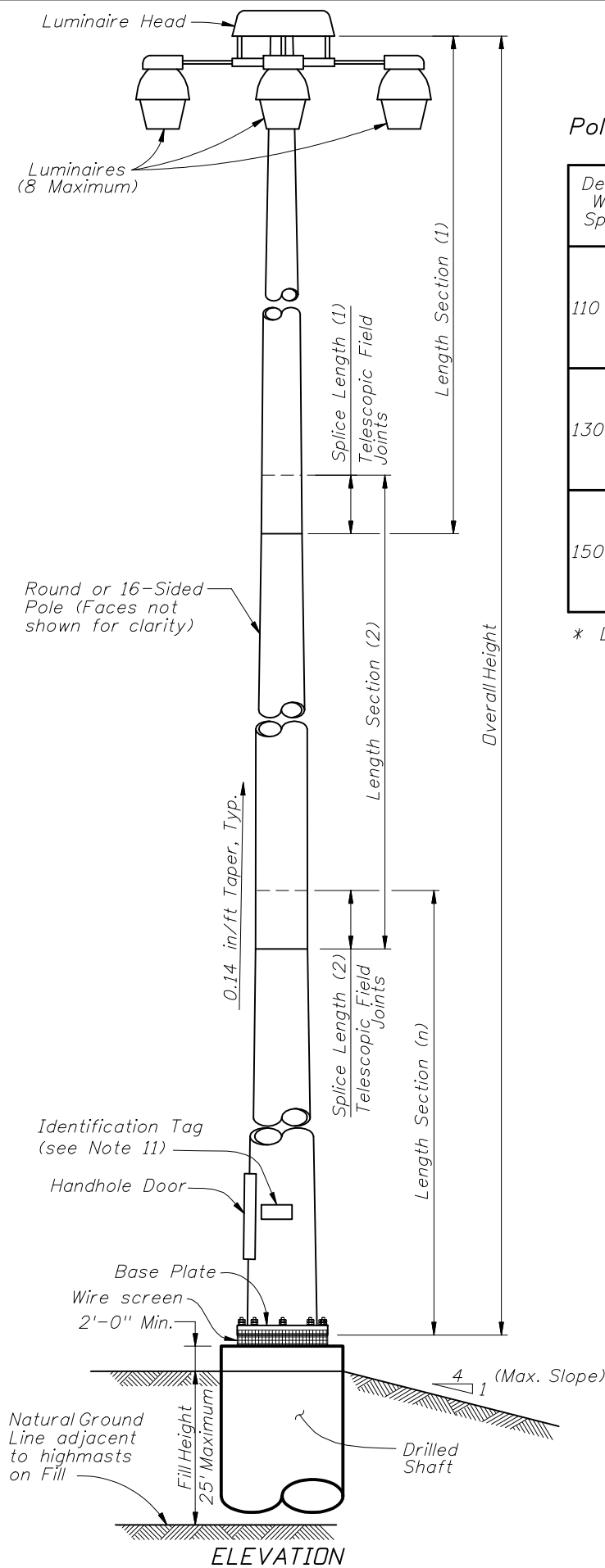

Pole Design Table*

Design Wind Speed	Pole Overall Height	Section 1 (Top)					Section 2					Section 3				
		Length.	Wall Th.	Minimum Splice L.	Tip Dia.	Base Dia.	Length.	Wall Th.	Minimum Splice L.	Tip Dia.	Base Dia.	Length.	Wall Th.	Minimum Splice L.	Tip Dia.	Base Dia.
110 mph	80 ft	42'-0"	0.250"	2'-0"	5.313"	11.219"	40'-0"	0.250"	---	10.375"	16.000"	---	---	---	---	---
	100 ft	24'-6"	0.179"	2'-0"	6.406"	9.844"	40'-0"	0.250"	2'-6"	9.188"	14.781"	40'-0"	0.250"	---	13.875"	19.500"
	120 ft	44'-9"	0.250"	2'-0"	6.250"	12.531"	40'-0"	0.250"	2'-9"	11.688"	17.313"	40'-0"	0.313"	---	16.375"	22.000"
130 mph	80 ft	42'-0"	0.250"	2'-0"	5.281"	11.188"	40'-0"	0.313"	---	10.375"	16.000"	---	---	---	---	---
	100 ft	24'-6"	0.179"	2'-0"	6.906"	10.344"	40'-0"	0.250"	2'-6"	9.656"	15.281"	40'-0"	0.313"	---	14.375"	20.000"
	120 ft	45'-6"	0.250"	2'-6"	9.250"	15.625"	40'-0"	0.250"	3'-0"	14.719"	20.344"	40'-0"	0.313"	---	19.375"	25.000"
150 mph	80 ft	42'-3"	0.250"	2'-3"	7.281"	13.219"	40'-0"	0.313"	---	12.375"	18.000"	---	---	---	---	---
	100 ft	24'-6"	0.250"	2'-0"	8.188"	11.625"	40'-0"	0.313"	2'-6"	10.781"	16.406"	40'-0"	0.375"	---	15.375"	21.000"
	120 ft	46'-6"	0.250"	3'-0"	12.406"	18.938"	40'-0"	0.313"	3'-6"	17.938"	23.563"	40'-0"	0.375"	---	22.375"	28.000"

* Diameter Measured Flat to Flat

Base Plate and Bolts Design Table

Design Wind Speed.	Pole Overall Height	Base Plate Diameter	Base Plate Thickness	"TW"	"BW"	Bolt Circle	No. Bolts	Bolt Diameter	Bolt Embedment
110 mph	80 ft	30.0"	2.500"	0.375"	0.188"	23.0"	8	1.75"	38"
	100 ft	33.5"	2.500"	0.375"	0.188"	26.5"	8	1.75"	42"
	120 ft	36.0"	2.750"	0.375"	0.250"	29.0"	8	1.75"	45"
130 mph	80 ft	30.0"	2.500"	0.438"	0.250"	23.0"	8	1.75"	43"
	100 ft	34.0"	2.750"	0.438"	0.250"	27.0"	8	1.75"	50"
	120 ft	41.0"	3.250"	0.500"	0.250"	33.0"	8	2.00"	52"
150 mph	80 ft	32.0"	2.750"	0.500"	0.250"	25.0"	8	1.75"	49"
	100 ft	37.0"	3.000"	0.563"	0.313"	29.0"	8	2.00"	53"
	120 ft	46.0"	3.250"	0.563"	0.313"	37.0"	10	2.25"	57"

Shaft Design Table

Design Wind Speed.	Pole Overall Height	Shaft Diameter	Shaft Length	Longitudinal Reinforcement
110 mph	80 ft	4'-0"	13'-0"	14 - # 11
	100 ft	4'-0"	15'-0"	14 - # 11
	120 ft	4'-6"	16'-0"	16 - # 11
130 mph	80 ft	4'-0"	14'-0"	14 - # 11
	100 ft	4'-0"	16'-0"	14 - # 11
	120 ft	4'-6"	18'-0"	16 - # 11
150 mph	80 ft	4'-0"	16'-0"	14 - # 11
	100 ft	4'-6"	17'-0"	16 - # 11
	120 ft	5'-0"	20'-0"	18 - # 11

POLE DESIGN TABLES



2010 FDOT Design Standards

HIGHMAST LIGHTING

Last Revision 01/01/09

Sheet No. 4 of 7

Index No. 17502

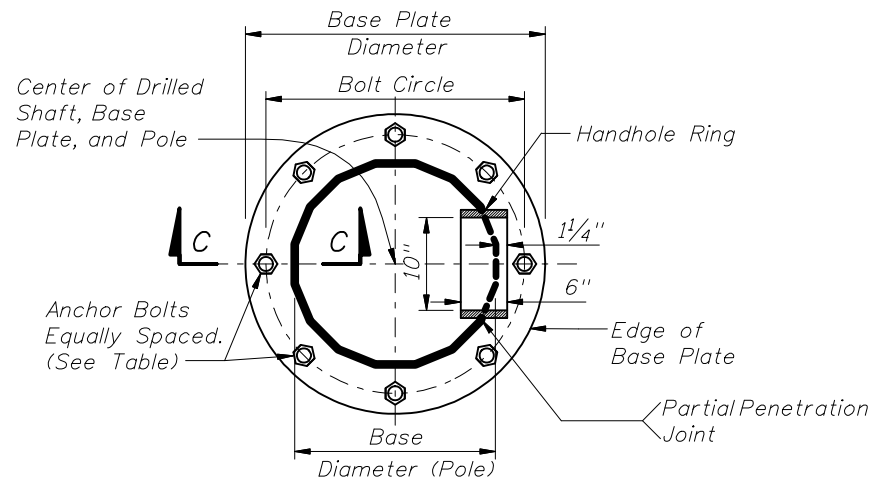

SECTION A-A
(T = Wall Thickness)

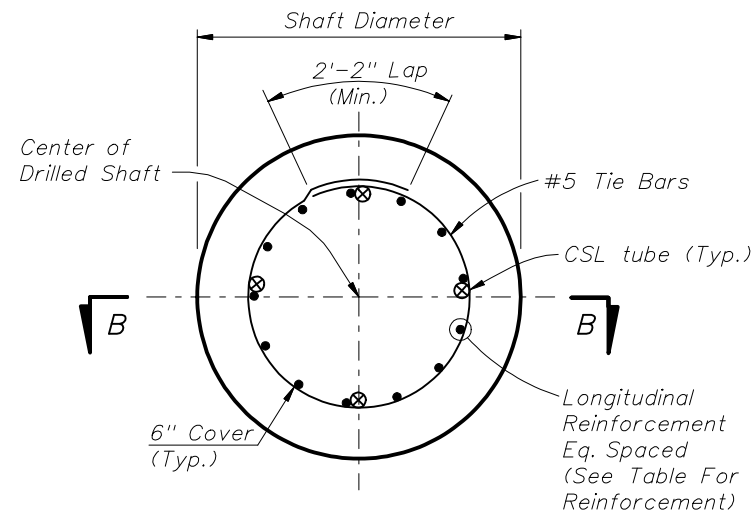

FOUNDATION PLAN
(Anchor Bolts and Conduits Not Shown)

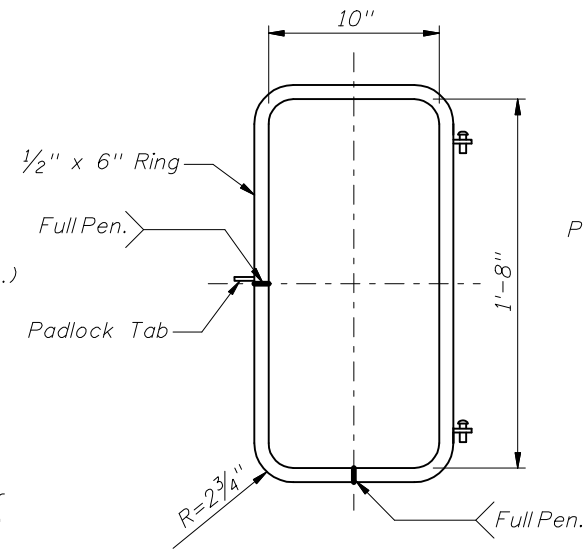

HANDHOLE RING

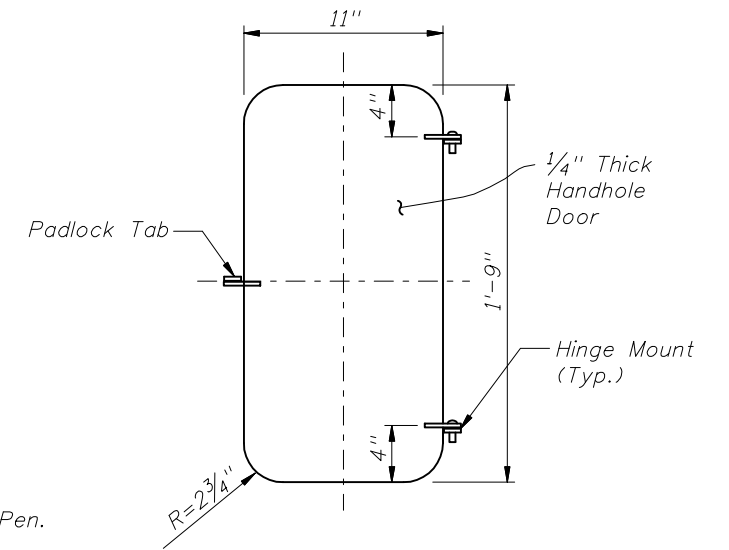

HANDHOLE DOOR

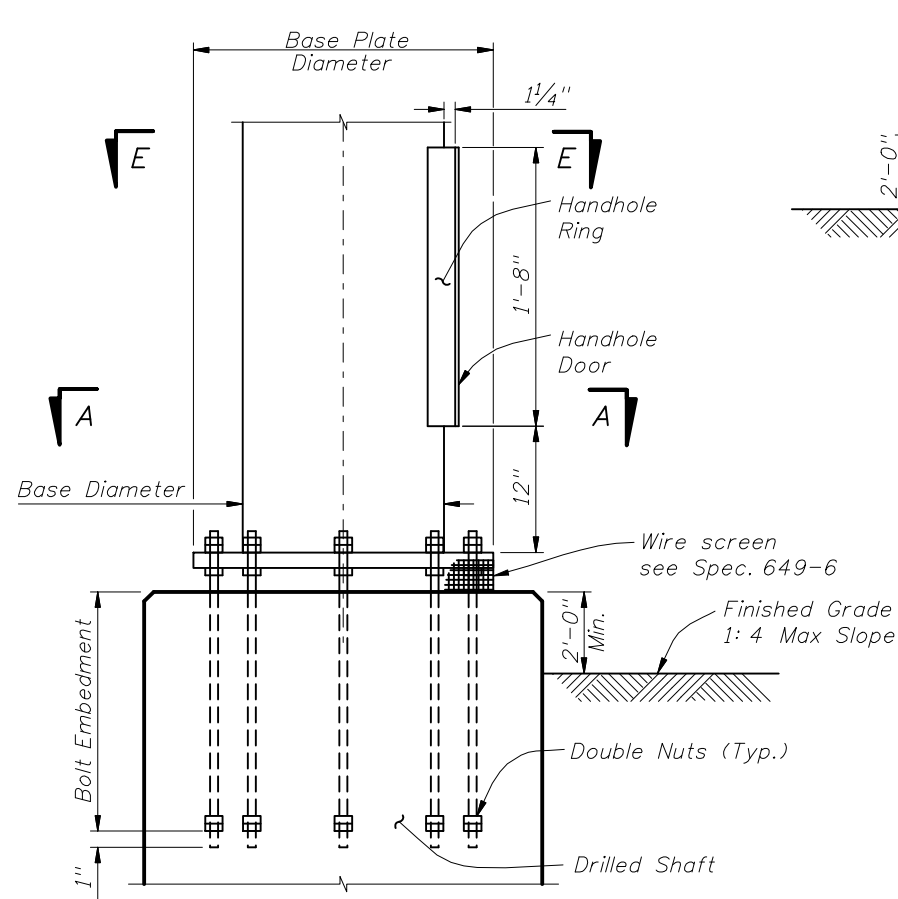

BASE PLATE AND ANCHORAGE ELEVATION
(Conduits Not Shown)

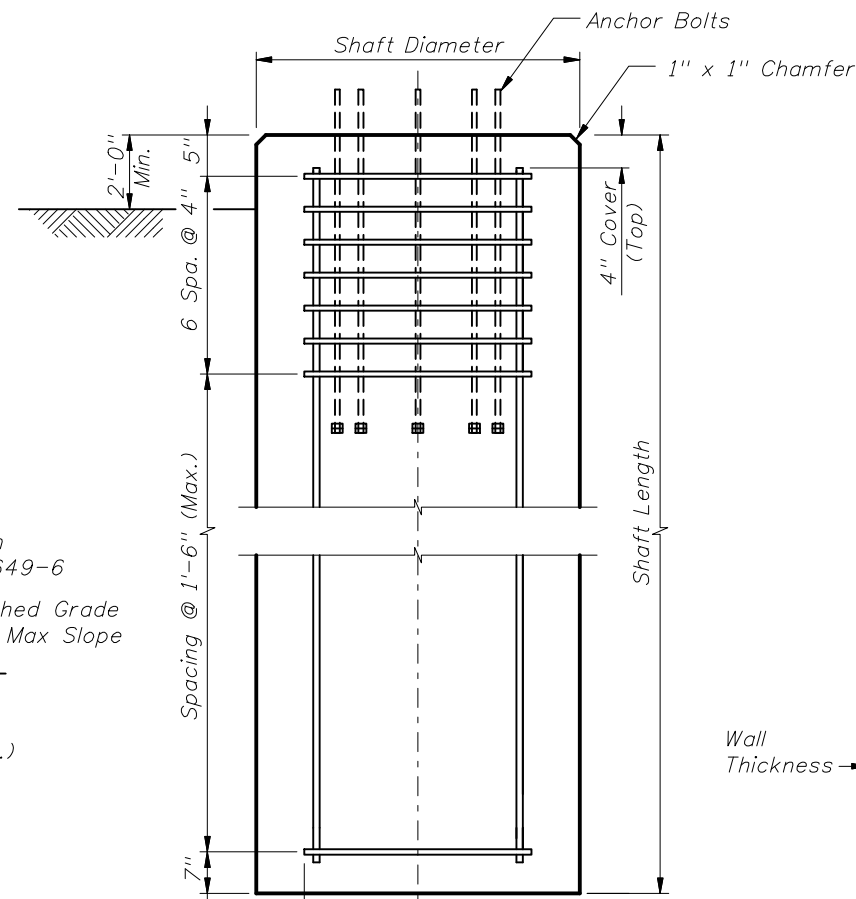

SECTION B-B
(Conduits Not Shown)

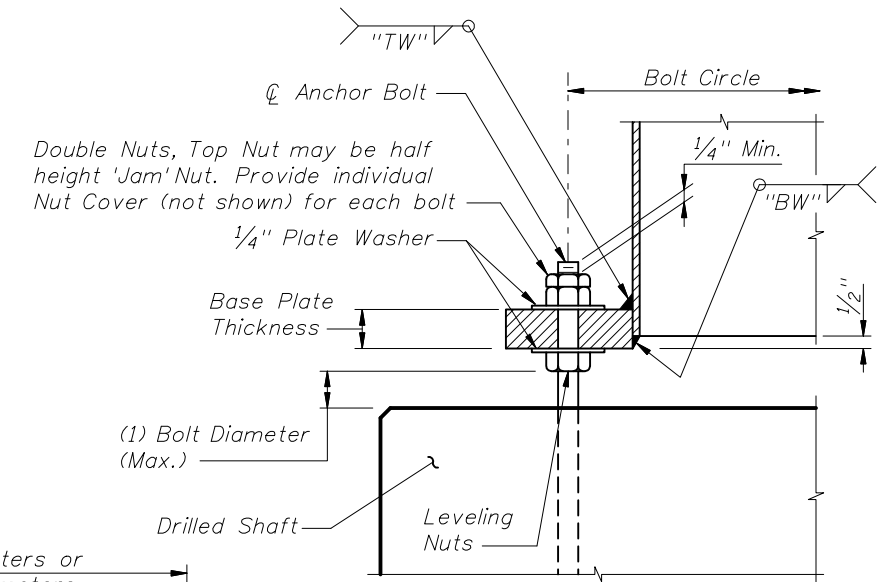

SECTION C-C

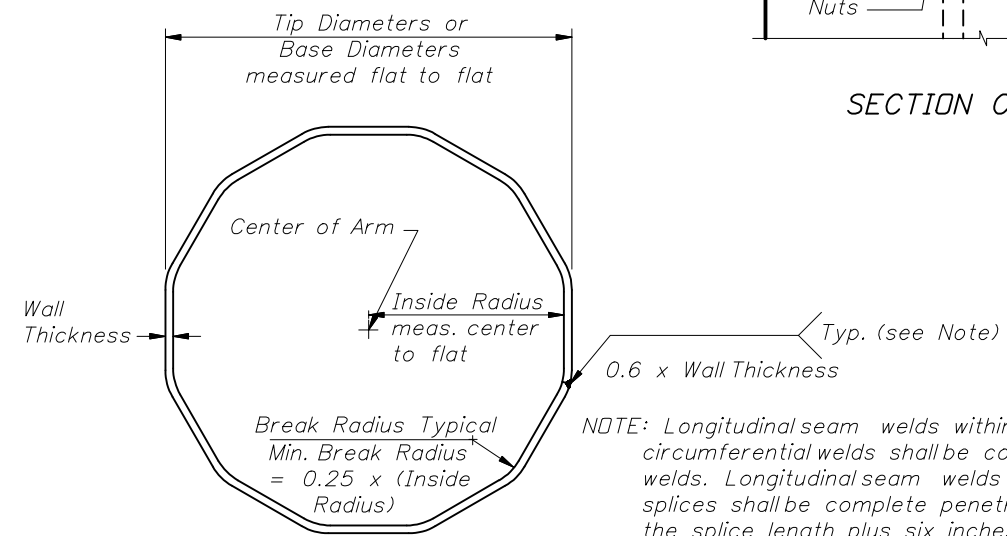

SECTION E-E

NOTE: Longitudinal seam welds within six inches of circumferential welds shall be complete penetration welds. Longitudinal seam welds at telescopic field splices shall be complete penetration welds for the splice length plus six inches. For tubes greater than 70" in circumference, two longitudinal seam welds are allowed.

POLE FOUNDATION



2010 FDOT Design Standards

HIGHMAST LIGHTING

Last Revision 01/01/09 Sheet No. 5 of 7

Index No. 17502

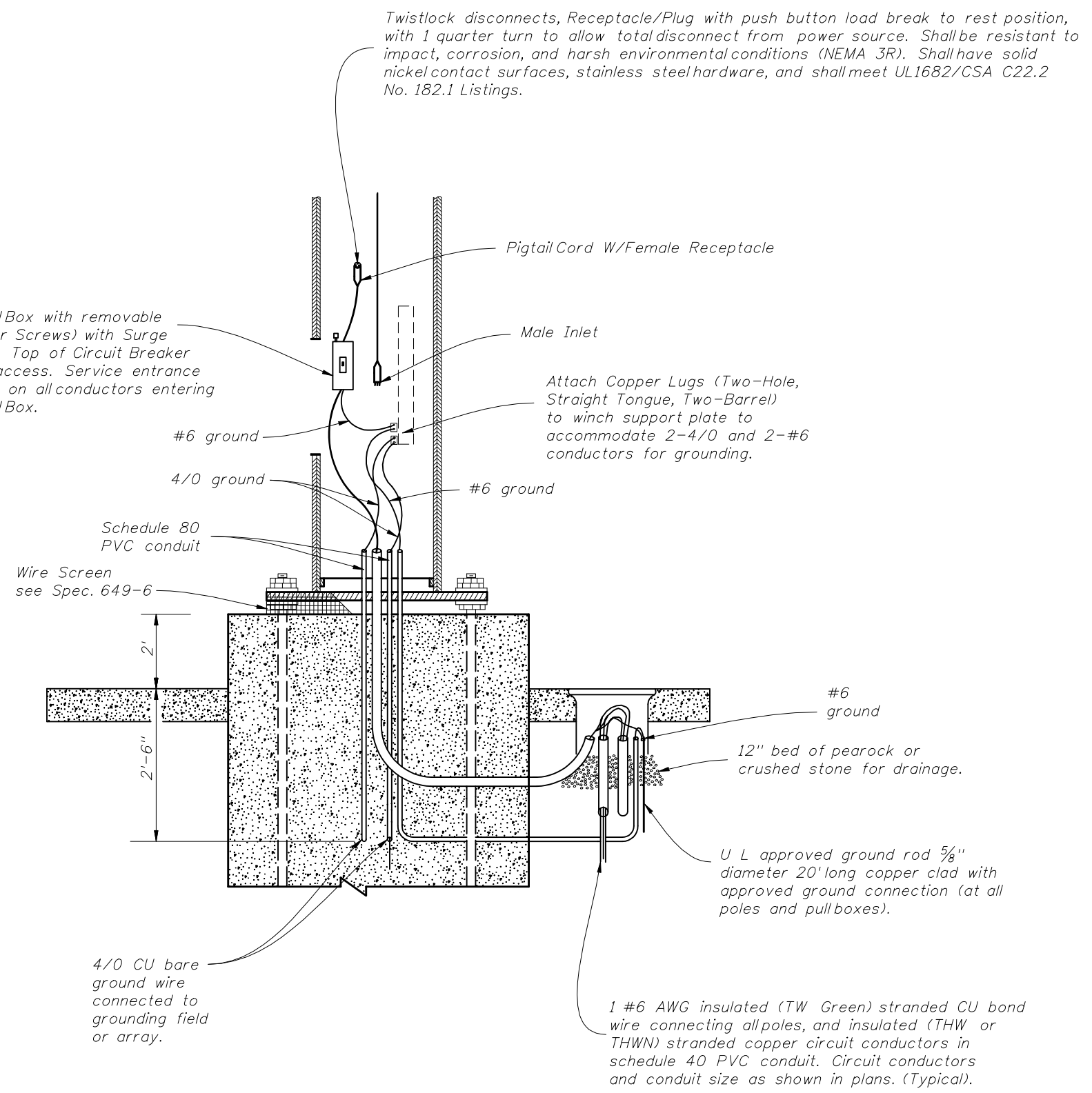
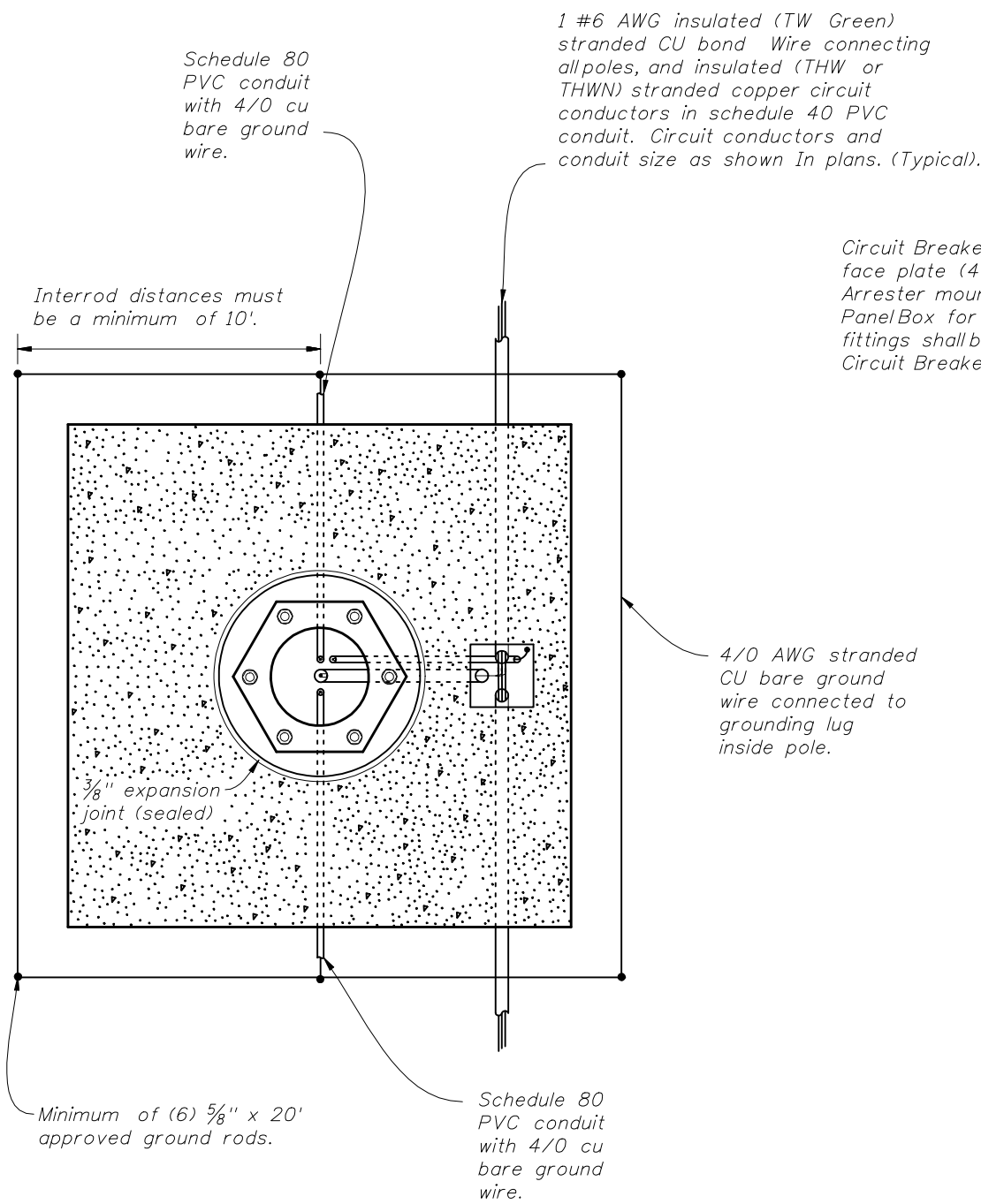

NOTES:

1. At all pullboxes and pole bases, ends of conduit shall be sealed in accordance with Section 630 of the Standard Specifications For Road And Bridge Construction.
2. Slabs to be placed around all Poles and Pull Boxes.
3. For Pull Boxes between Poles refer to Index 17500.

WIRING DETAILS



2010 FDOT Design Standards

HIGHMAST LIGHTING

Last Revision	Sheet No.
07/01/09	6 of 7
Index No.	
17502	

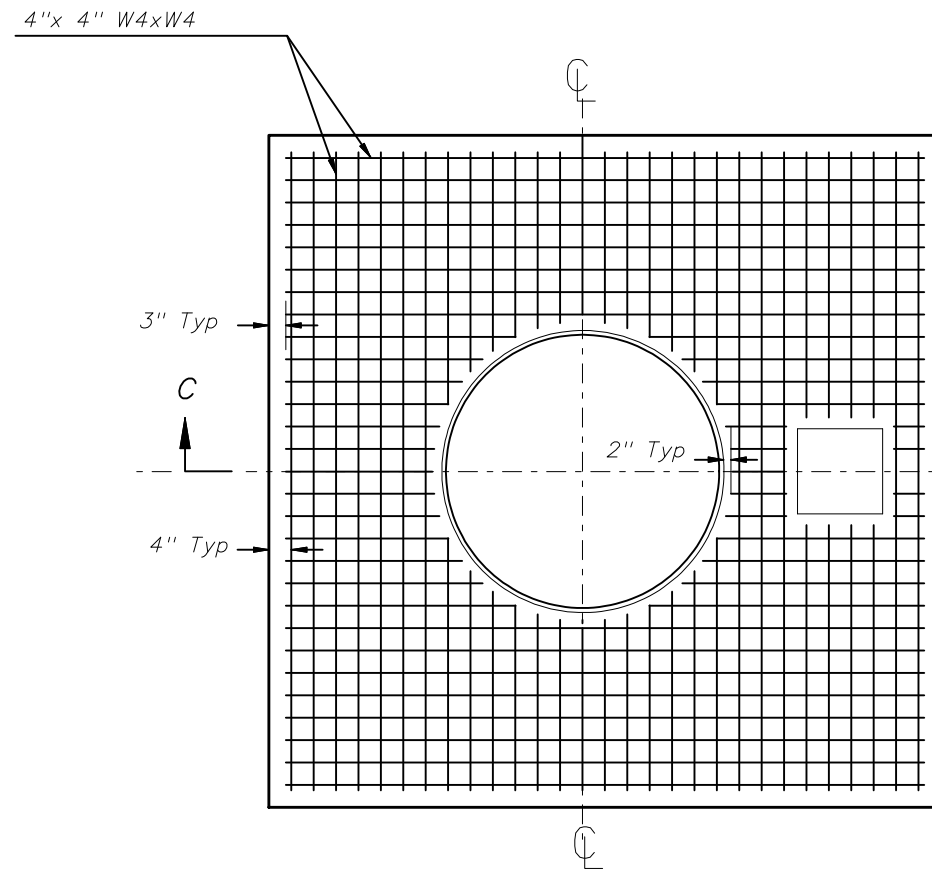

REINFORCEMENT LAYOUT

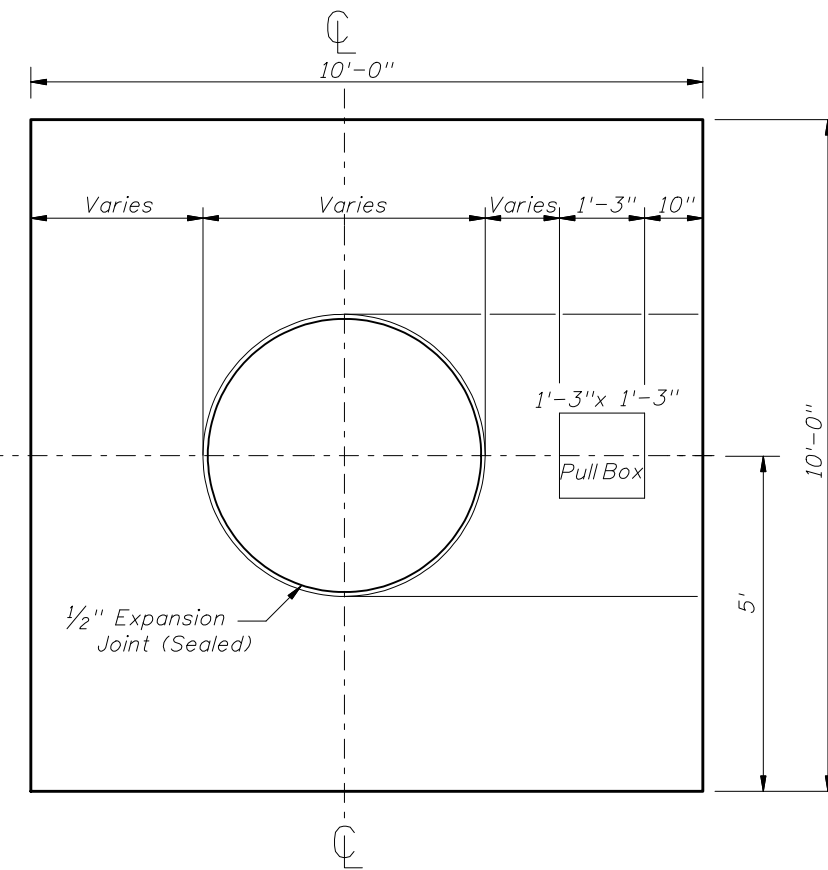

SLAB DIMENSIONS

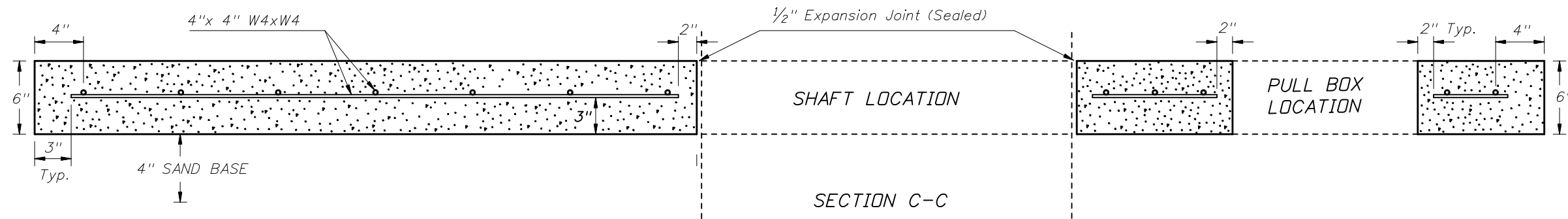

SECTION C-C

NOTES:

1. Use clean free draining sand less than 5% passing No. 200 sieve for base (4").
2. Welded wire fabric shall meet the requirements of ASTM A185.
3. Concrete shall be Class NS with a minimum strength at 28 days of $f'c=2.5$ ksi.
4. Outside edges of slab shall be cast against formwork.
5. The pullbox shown is 1'-3" x 1'-3"; others approved under Section 635 of the Standard Specifications may be used.
6. Slabs to be placed around all Poles and Pull Boxes in rural locations. In urban areas or where space is limited slab dimensions may be adjusted as shown in the plans.
7. Concrete and reinforcing for slabs around poles and pullboxes shall be included in the price of pole or pullbox.
8. The 1/2" thick expansion joint between the pole shaft and slab and the pullbox and slab shall be sealed with a hot poured elastic joint sealer.

SLAB DETAILS



2010 FDOT Design Standards

HIGHMAST LIGHTING

Last Revision	Sheet No.
07/01/09	7 of 7
Index No.	
17502	

NOTE :

It shall be the contractor's responsibility to provide a complete service assembly as per the plans and service specifications. The service installation shall meet the requirements of the national electric code and applicable local codes. Shop drawings are not required for service equipment, unless noted in the plans.

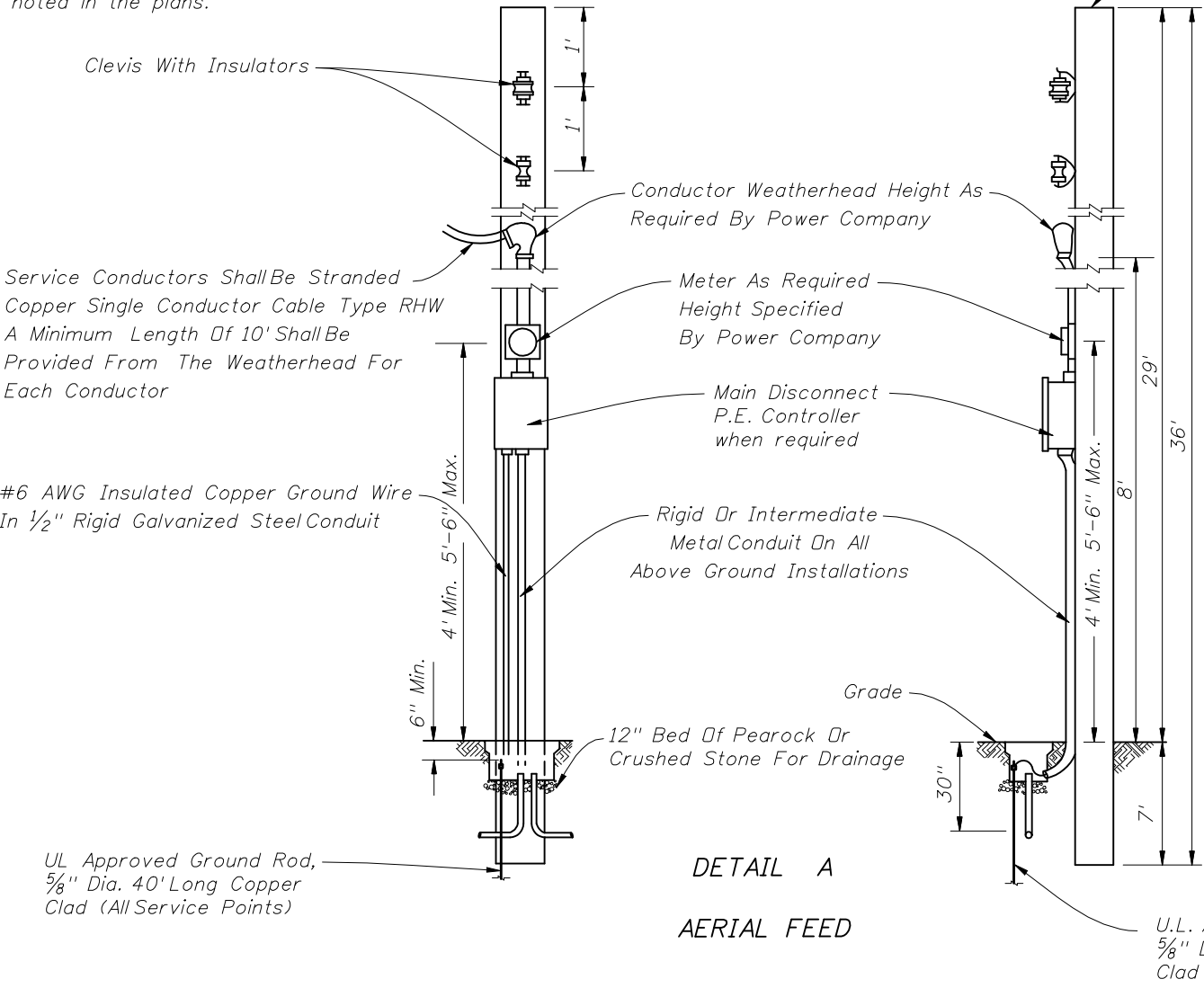

DETAIL A
AERIAL FEED

SERVICE SPECIFICATIONS

1. The main disconnect shall be NEMA 3R, pole mounted.
2. The enclosure door shall be lockable by padlock and four keys provided to the maintaining agency. The door shall have a minimum of three hinges and be latchable. No screws to be used to attach door.
3. 480 Volt minimum rating bolt-in type breakers shall be used.
4. Busbar to be copper coated and have a minimum rating of 100 amps. When main breaker exceeds 100 amps busbar to match breaker amperage.
5. Locate Contactor, Transformer, P.E. Controller, and H.D.A. Switch inside enclosure. The enclosure to be sized to accommodate as many breakers as called for and all other service equipment.
6. The enclosure to be rigidly attached to the pole face.
7. A 600 Volt lightning protector shall be wired inside the enclosure.
8. A main breaker is required in all service panels with 2 or more feeder breakers.
9. All service equipment shall be U. L. approved.

Concrete Pole Prestressed Type P-II, 36' Long

#6 AWG Insulated Copper Ground Wire In 1/2" Rigid Galvanized Steel Conduit

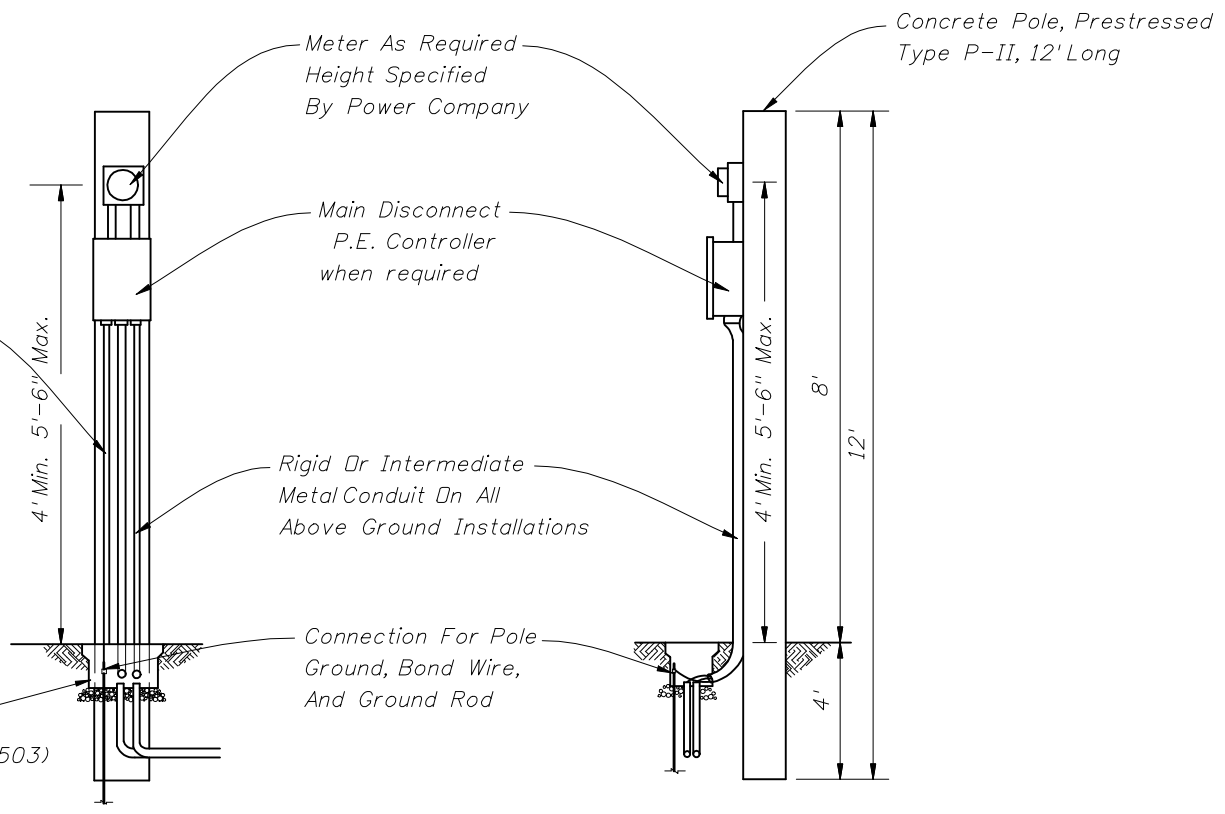

DETAIL B
UNDERGROUND FEED

NOTES:

1. Photo Electric Control as required.
2. All neutral wires to have White insulation, do not use White or Green insulated wires for ungrounded conductors.
3. A Pull Box is required at each service point.

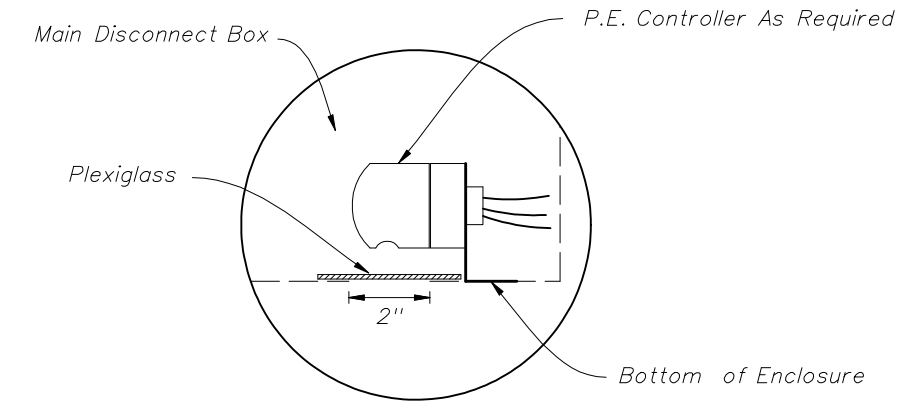

Cut a 2" hole in the bottom of the Main Disconnect Box for the operation and mounting of the P.E. controller. Use plexiglass and a clear silicone sealant to cover hole, install P.E. Controller.

PHOTO ELECTRIC CONTROLLER DETAIL

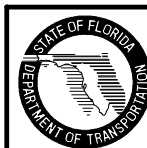

SIGN LIGHTING INSTALLATION

Roadway Lighting included in contract:

The power for the sign lighting shall be provided from the roadway lighting circuit. The lighting plans shall indicate the sign location and a pull box location for connection to the sign lights. The lighting contractor shall install pull box and loop 2' of lighting circuit conductors in the pull box for connection by the signing contractor.

The signing contractor shall furnish and install luminaires, Nema 3R enclosure, 30 amp breaker, conduit, conductors and all other electrical equipment necessary for connection to the lighting circuit.

Roadway Lighting not included in contract:

The signing plans shall include pay item numbers to furnish and install conduit, conductors, ground rods, pull boxes and service point equipment. The signing plans shall indicate the location of the service point equipment and circuit runs. The signing contractor shall provide all electrical equipment necessary for connection of the sign lights.

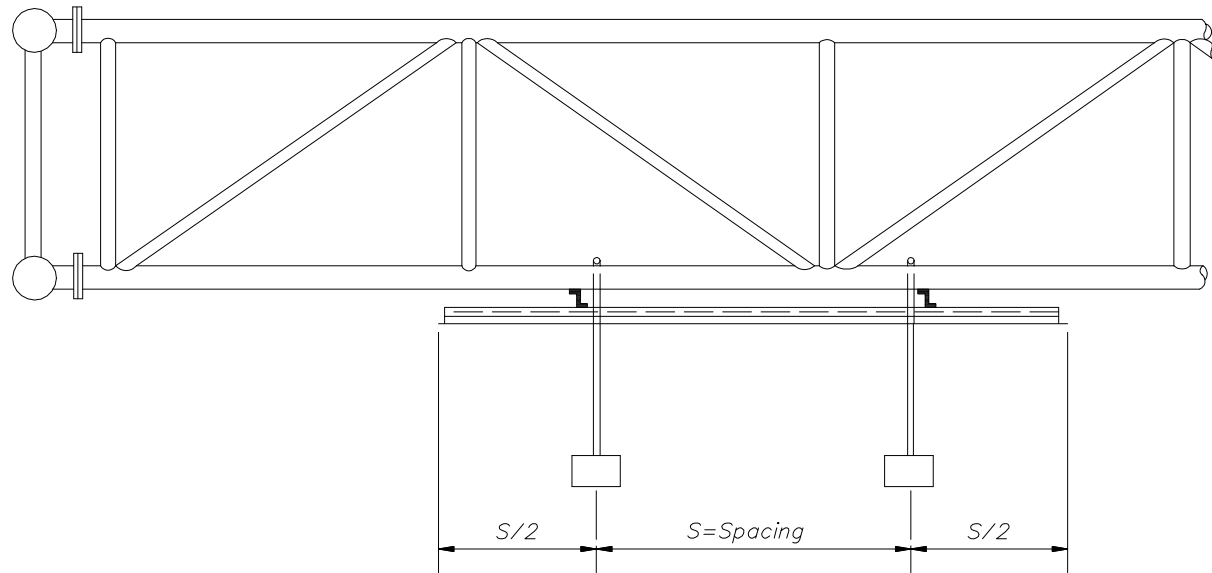

PLACEMENT OF SIGN LIGHTS

1. Luminaire shall be mounted so the lamp center is 4' in front of the sign face.
2. Luminaire shall be mounted so the back of the fixture is placed 1' below the bottom edge of the sign face.
3. Luminaires from manufacturers who recommended their fixture be tilted shall be mounted on a bracket which provides this recommended tilt.
4. Photometric data for the Induction luminaire proposed for sign lighting shall be submitted for approval to the District Lighting Engineer, Florida Department Of Transportation.

Use 3/4" Liquid Tight Flexible Conduit From Junction Box To Ballast And From Junction Box To Tee In Luminaire Bracket. Conduit Shall Be Of Sufficient Length To Allow Rotation Of Luminaire Bracket 90 In Either Direction.

Ballast Shall Be Mounted To Sign Chord With Stainless Steel Band. Bracket For Ballast To Be Fabricated From Galvanized Steel Plate For Steel Sign Structures And Aluminum Plate For Aluminum Sign Structures. (Submittal Data Required)

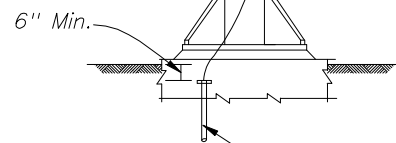
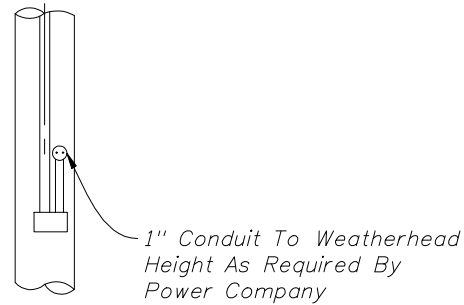
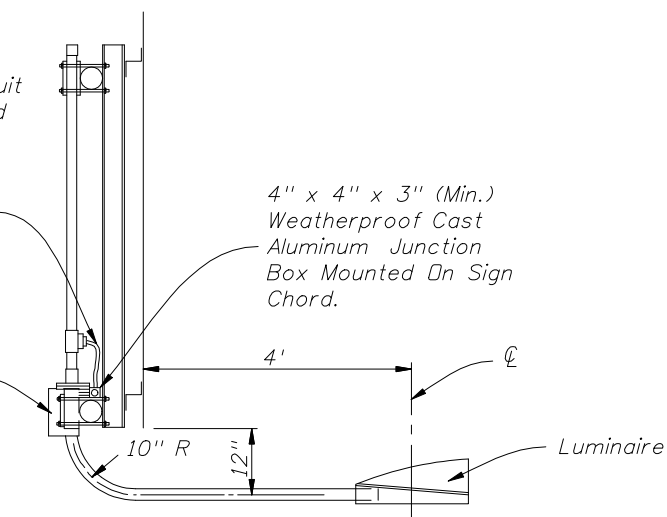

PLAN
OVERHEAD POWER SUPPLY

U.L. Approved Ground Rod 5/8" x 20' Copper Clad With Approved Ground Connection To Be Placed In Pull Box For Inspection Purposes. Splices To Be Made With Compression Sleeves Then Properly Insulated & waterproofed

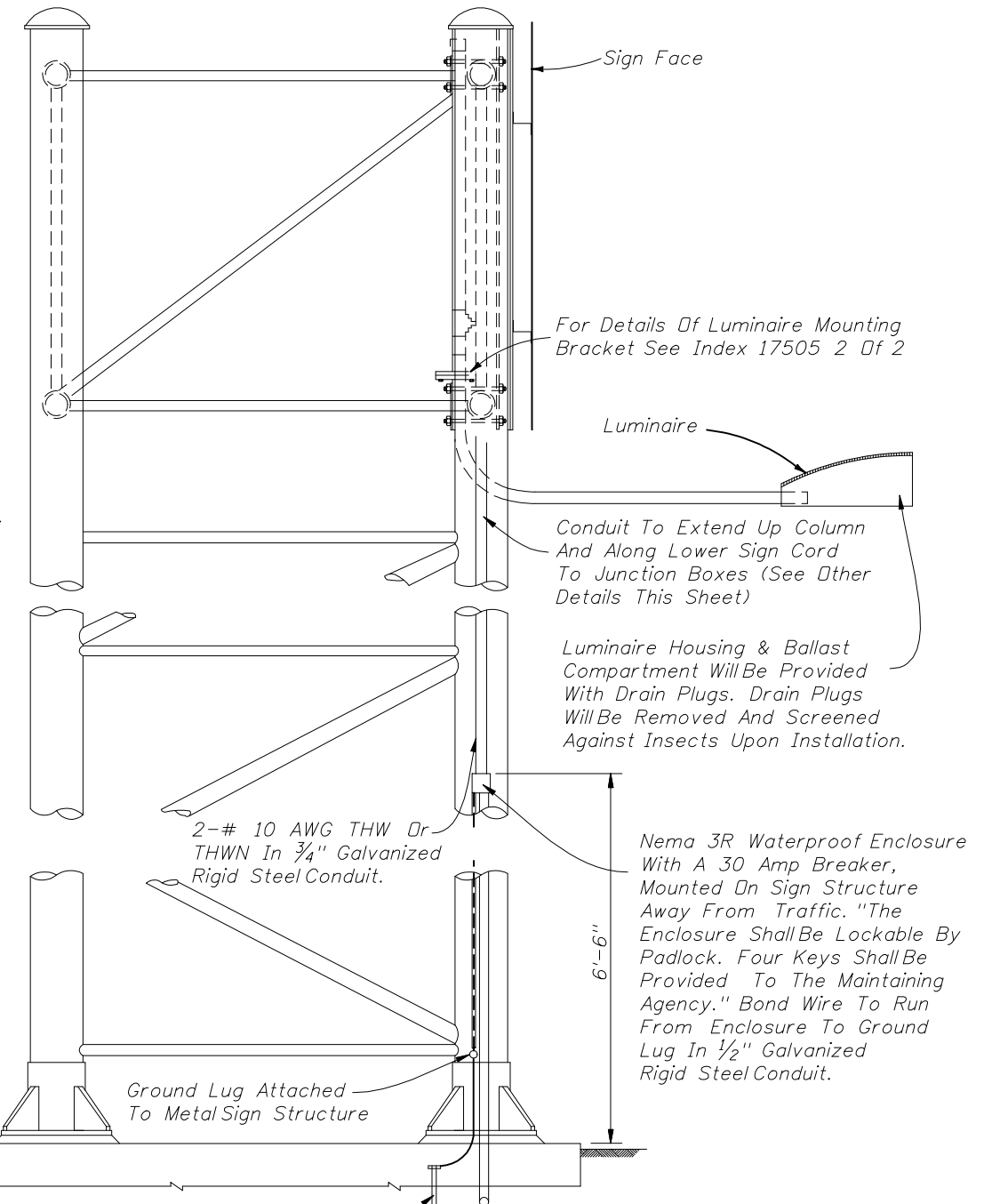

2010 FDOT Design Standards

EXTERNAL LIGHTING FOR SIGNS

Last Revision 07/01/09	Sheet No. 1 of 2
Index No. 17505	

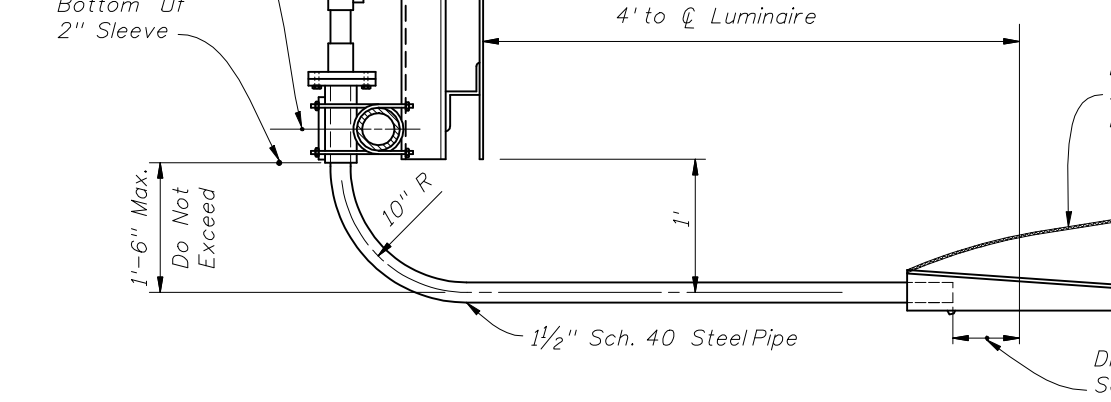
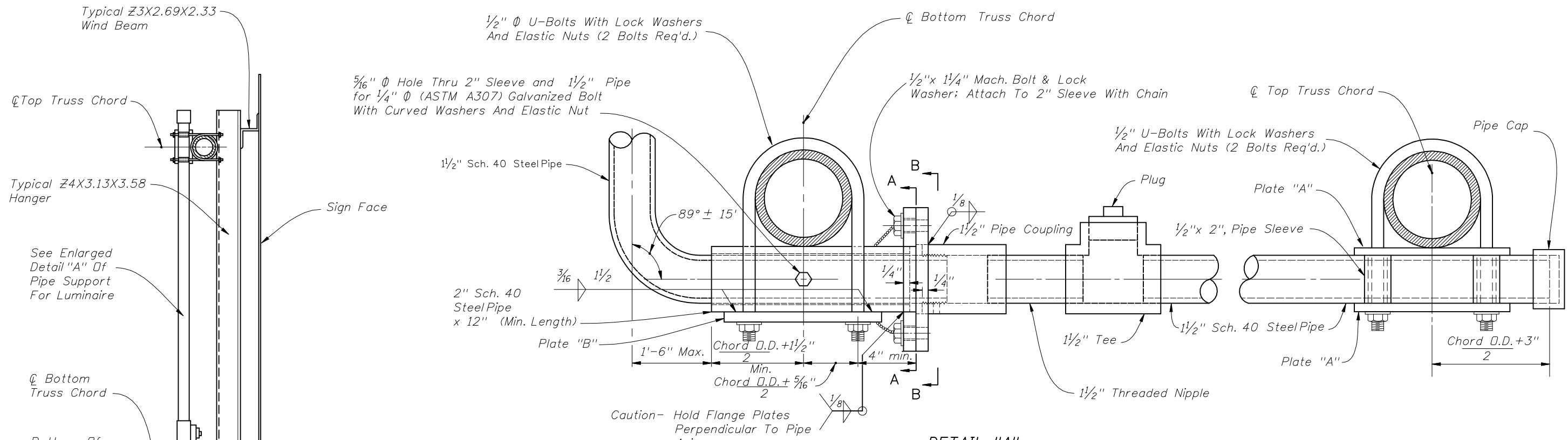

SECTION THROUGH SIGN SUPPORT AT LUMINAIRE

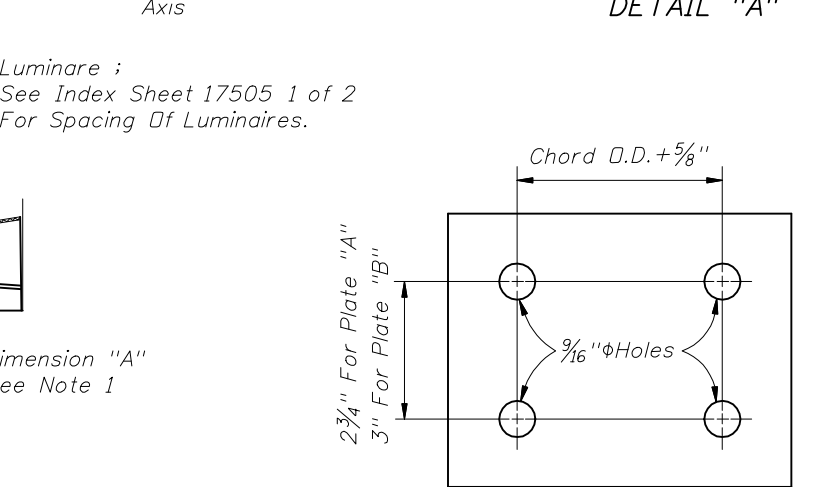

DETAIL "A"

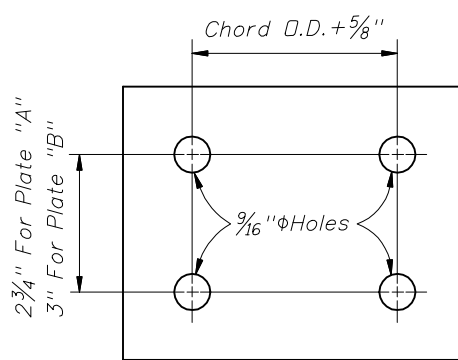
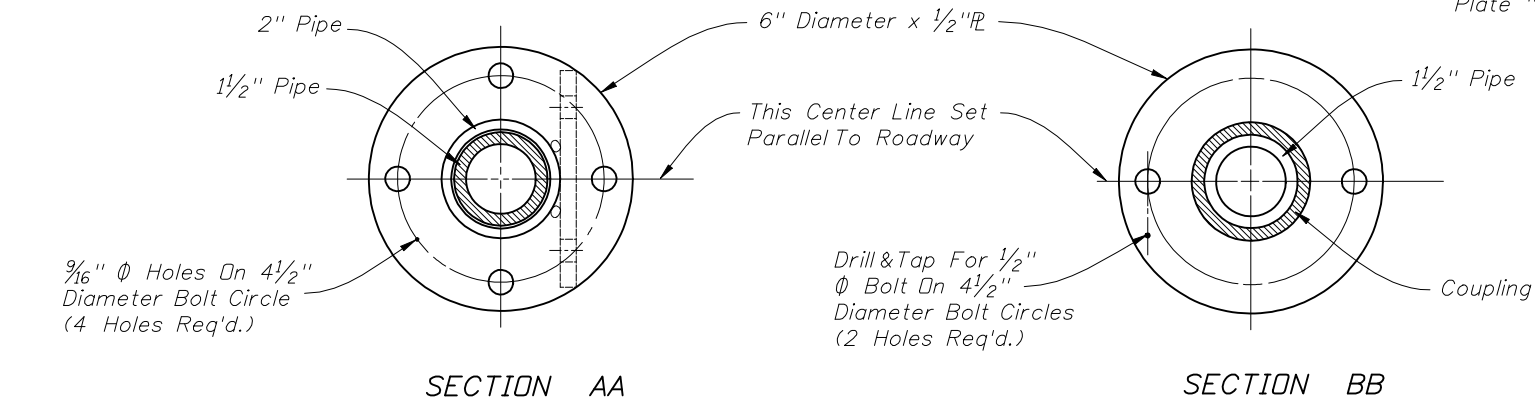

Plate "A": 1/4" x 4 3/4" x Chord D.D. + 2 1/2"
 Plate "B": 3/8" x 5" x Chord D.D. + 2 1/2"

NOTES

- 1 Dimension "A" to be established by type and make of luminaire to be purchased and used on the project.
- 2 The center lines of both flange plates and the luminaire support arm are to be set parallel to the roadway before the set screw is seated.
- 3 Minor adjustments in the horizontal location of the luminaire support arm along the bottom chord of the truss will be allowed so that the flange plates will clear the truss web members.
- 4 All steel pipe shall meet the strength requirements of ASTM Specification A53 Grade "A" or Grade "B". Steel plates shall meet the requirements of A36 and bolts, nuts and washers shall meet the requirements of ASTM A307.
- 5 All items shall be hot dip galvanized after fabrication in accordance with the requirements of ASTM A123 and /or A153.
- 6 Luminaire support arm shall be free to rotate in a clockwise or counter clockwise direction. When service or maintenance is required for sign face or vertical face of truss; Support arm shall be capable of being locked in a position 90° from parallel to the roadway for unobstructed working clearance.



SECTION AA

SECTION BB



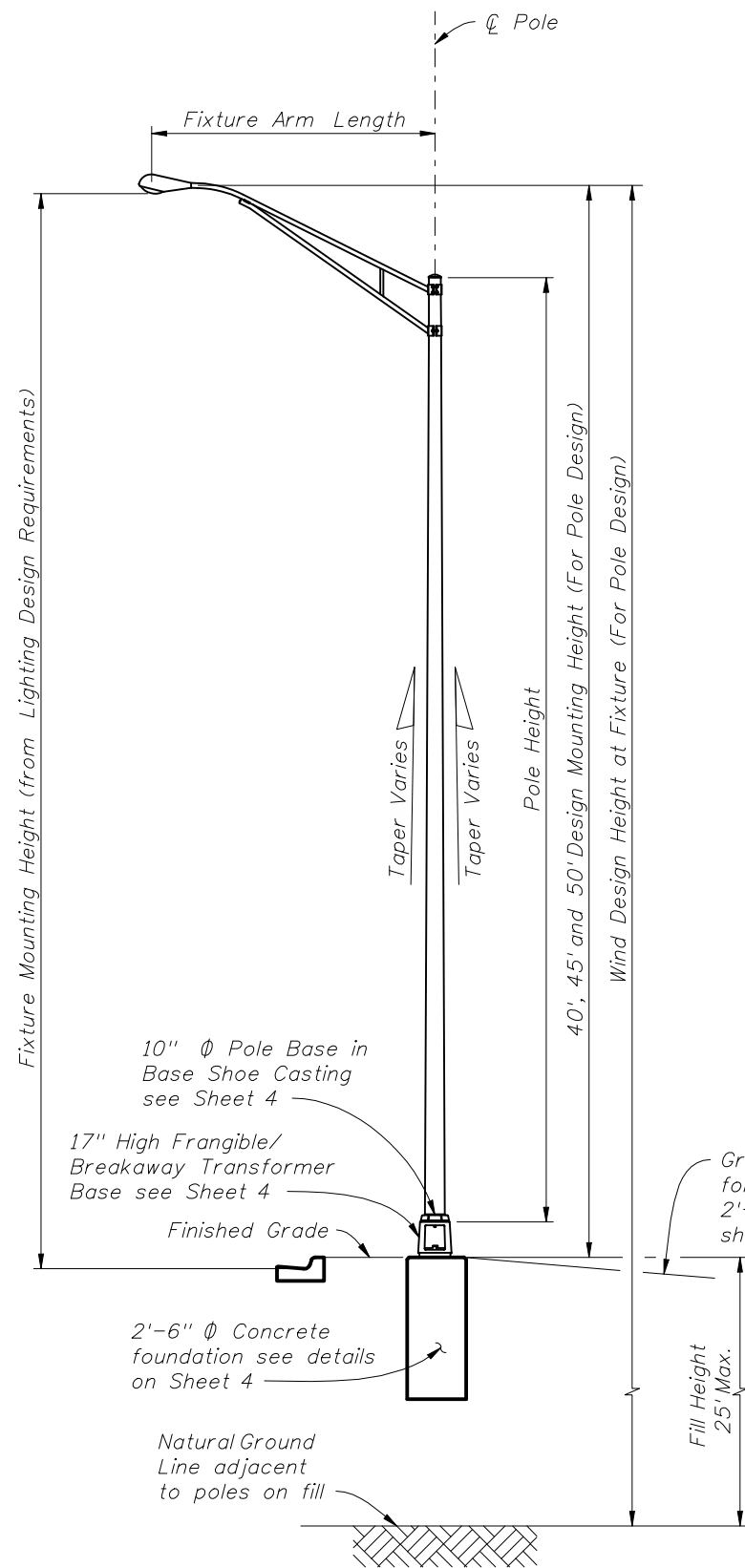

STANDARD ROADWAY ALUMINUM LIGHT POLE

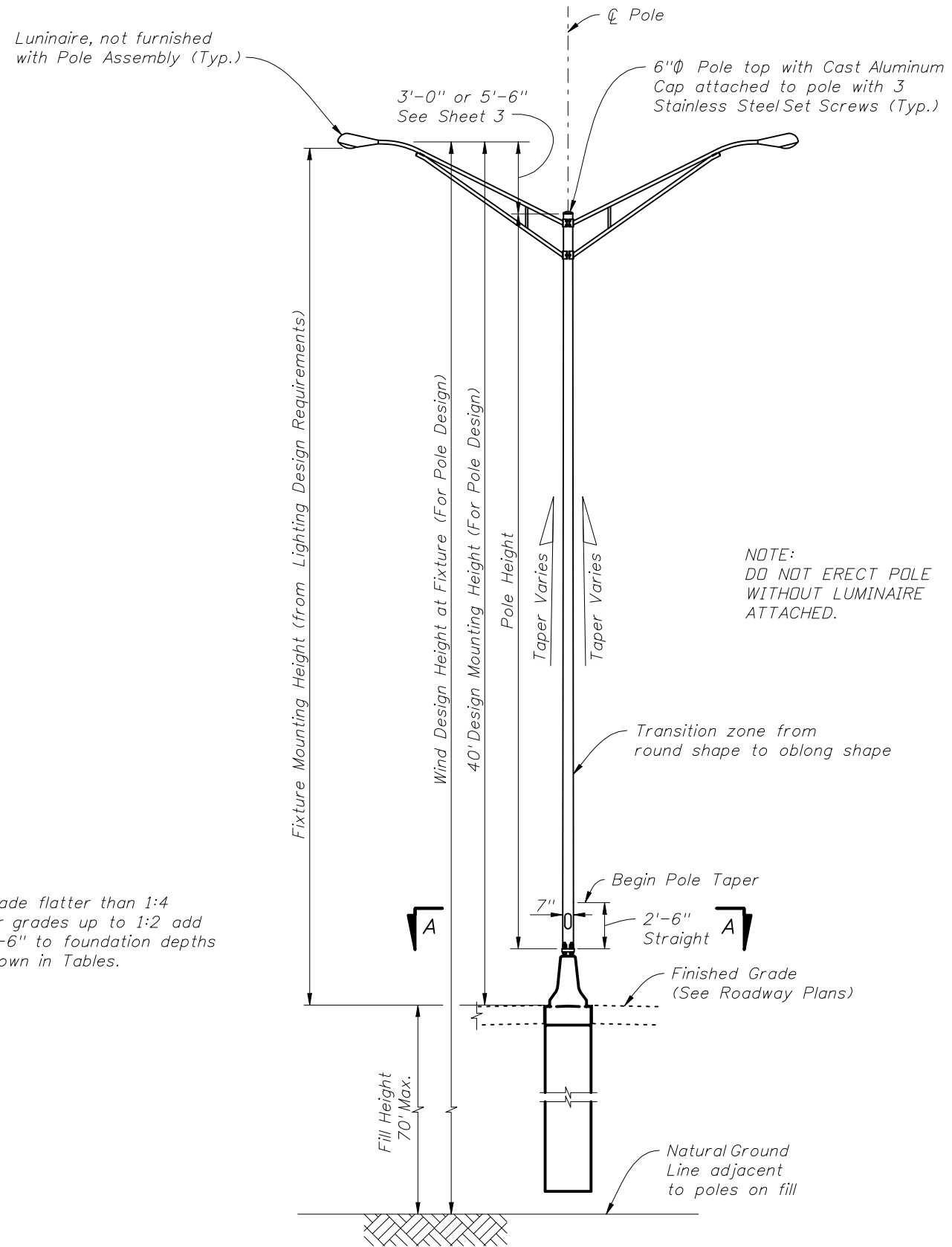

MEDIAN BARRIER MOUNTED ALUMINUM LIGHT POLE ON CYLINDRICAL FOUNDATION

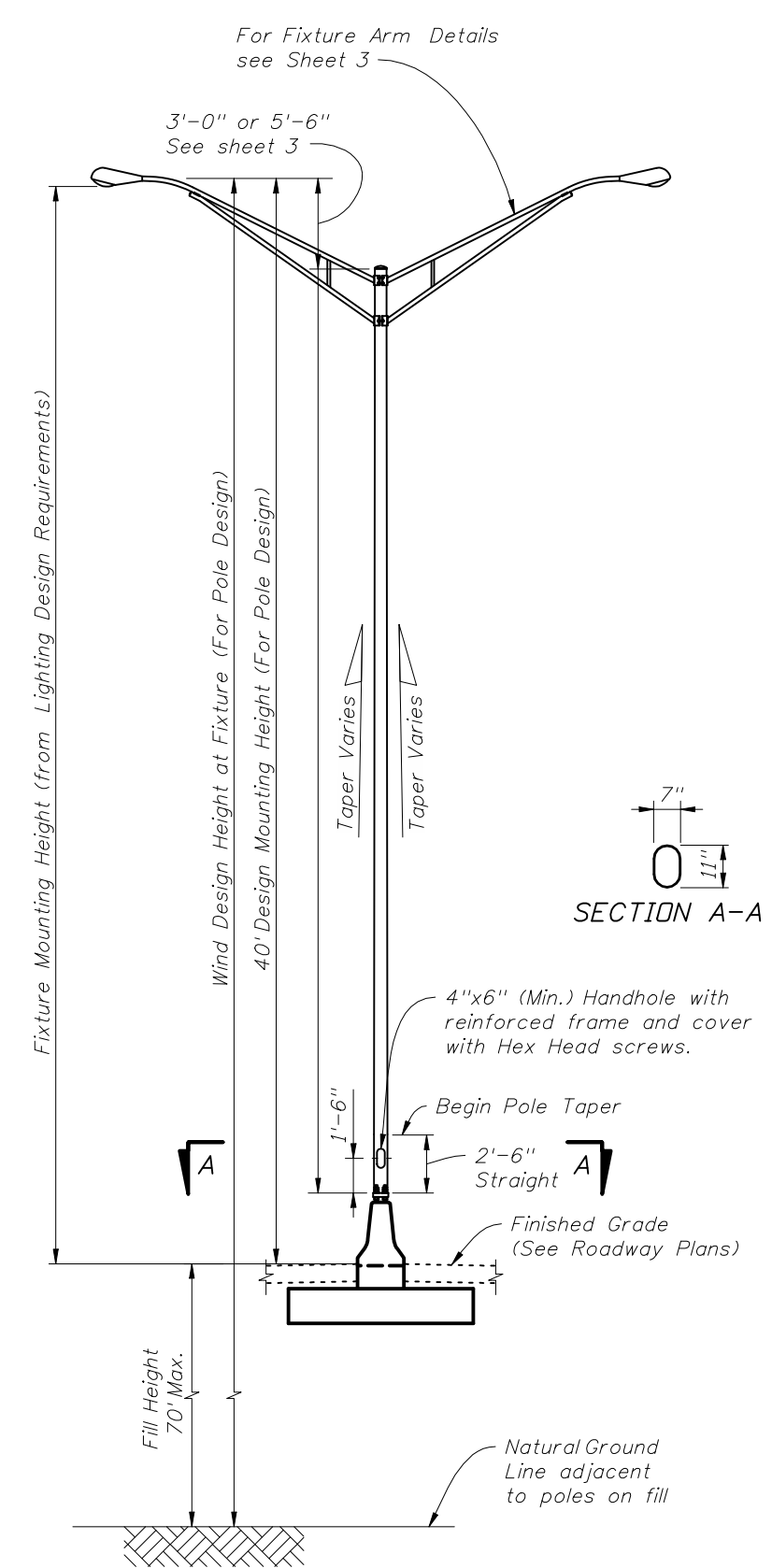

MEDIAN BARRIER MOUNTED ALUMINUM LIGHT POLE ON SPREAD FOOTING FOUNDATION

NOTE:
DO NOT ERECT POLE WITHOUT LUMINAIRE ATTACHED.

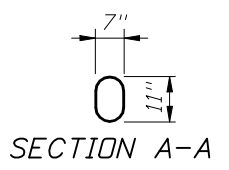

ELEVATIONS



2010 FDOT Design Standards

STANDARD ALUMINUM LIGHTING

Last Revision 07/01/09 Sheet No. 1 of 8

Index No. 17515

ALUMINUM LIGHT POLE GENERAL NOTES

- 1) Designed in accordance with FDOT Structures Manual (current edition).
- 2) All tables were developed assuming the following Luminaire properties: Effective Projected Area of 1.55 ft. (includes wind drag coefficient) and 75 pounds (max.)
- 3) Perform all welding in accordance with the American Welding Society Structural Welding Code Aluminum ANSI/AWS D1.2 (current edition).
- 4) See Standard Index No. 17500 for grounding and wiring details.
- 5) Light Pole Specifications:
 - a. Poles: ASTM B221, Alloy 6063-T6.
 - b. Arm Tube Extrusions: ASTM B221 - Alloy 6063-T6.
 - c. Finish: For pole and arms: 50 grit satin rubbed finish.
 - d. Pole Connection Extrusions, Bars and Plates: ASTM B221 - Alloy 6063-T6.
 - e. Aluminum Caps and Covers: ASTM B-26(319-F).
 - f. Weld Metal: ER4043.
 - g. Stainless Steel Fasteners and Hardware: AISI Grade 304.
 - h. Aluminum alloy 6063: T4 condition and heat treated in accordance with ASTM B597 to T6.
- 6) Provide "J", "S" or "C" hook at top of pole for electrical cable.
- 7) Furnish each pole with a 2"x4" (max) aluminum identification tag. Submit details for approval. Secure to Transformer Base with 0.125" stainless steel rivets or screws. Locate Identification Tag on the inside of base and visible from the door opening. Include the following information: Financial Project ID, Pole Height, Manufacturer's Name, Certification number and QPL Number.
- 8) Manufacturers seeking approval of a Standard Roadway Aluminum Lighting Pole assembly for inclusion on the Qualified Products List must submit a QPL Product Evaluation Application along with design documentation and drawings showing the product meets all specified requirements of this Index.
 - a. For Clamp and Frangible Transformer Base Design, provide design calculation and/or test results indicating that the components are capable of providing the required capacity. Certify that the frangible Transformer Base conforms to the current FHWA required AASHTO Frangibility Requirements, tested under NCHRP Report 350 Guidelines.
 - b. For Median Barrier Mounted Aluminum Light Pole design, provide test results showing that pole will not buckle at pole shape transition area. Demonstrate in the tests that the poles will achieve full ultimate moment capacity of 36 k-ft in the strong axis and 30 k-ft in the weak axis respectively for the 0.25" thick poles, and 44 k-ft in the strong axis and 37 k-ft in the weak axis respectively for the 0.313" thick poles. Submit complete details and calculations for the reinforced 4"x6" (min.) handhole located 1'-6" above the base plate.
 - c. For Alternate foundations: Include design calculations and drawings showing that the product meets the requirements of this index, FDOT Structures Manual and Specification 715.

ROADWAY ALUMINUM LIGHTING POLE NOTES

- 1) Foundation Materials:
 - a. Reinforcing Steel: ASTM A615 Grade 60.
 - b. Concrete: Class I.
 - c. Anchor Bolts: ASTM F1554 Grade 55 with ASTM A563 Grade DH nuts and ASTM F436 Type 1 washers (all galvanized in accordance with ASTM F2329).
- 2) Shoe Base and Frangible/Breakaway Transformer Base Casting Specifications.
 - a. Shoe Base Casting: ASTM B26 - Alloy 356-T6 or ASTM B108 - Alloy 356-T6.
 - b. Frangible/Breakaway Transformer Base Casting: ASTM B26 - Alloy 356-T6 or ASTM B108 - Alloy 356-T6.
 - c. Shoe Base Connection Bolts: ASTM A325 Type 1 with ASTM A563 Grade DH nuts and ASTM F436 Type 1 washers (all galvanized in accordance with ASTM F2329).
- 3) Pole Notes:
 - a. Tapered as required to provide a top outside diameter (D.D.) of 6" with a base D.D. of 10". Portions of the shaft near the base shoe and at the arm connections may be held constant at 10" and 6" respectively to simplify fabrication.
 - b. Transverse welds are allowed only at the base.
 - c. Poles constructed out of two or more sections with overlapping splices are not permitted.
 - d. Equip poles with a damping device if the pole location is within 5 miles of the coastline.

MEDIAN BARRIER MOUNTED ALUMINUM LIGHT POLE

- 1) Foundation Materials:
 - a. Reinforcing Steel: ASTM A615 Grade 60.
 - b. Concrete: Class I.
 - c. Anchor Bolts: ASTM F1554 Grade 55 with ASTM A563 Grade DH nuts and ASTM A36 Plate Washer or ASTM F436 Type 1 washers (all galvanized in accordance with ASTM F2329). Coupler shall be in accordance with AASHTO 5.11.5.2.2.
- 2) Base Connection Materials:
 - a. Aluminum Base Plate and Stiffener: Alloy 6061-T6.
 - b. Backer Ring: ASTM B221, Alloy 6063-T6.
 - c. Bearing Plate for Anchor Bolts: ASTM A709 Grade 36 or ASTM A36.
- 3) Pole Notes:
 - a. Tapered as required to provide a 6" (D.D.) round top with a 11"x7" (D.D.) oblong base. Portions of the shaft near the base and at the arm connections may be held constant at 11"x7" oblong and 6" round respectively to simplify fabrication.
 - b. Transverse welds are allowed only at the base.
 - c. Poles constructed out of two or more sections with overlapping splices are not permitted.
 - d. Equip poles with a damping device.

FOUNDATION NOTES

The foundations for Standard Roadway Aluminum Light Poles are pre-designed and are based upon the following conservative soil criteria which covers the majority of soil types found in Florida:

Classification = Cohesionless (Fine Sand)
 Friction Angle = 30 Degrees (30°)
 Unit Weight = 50 lbs./cu. ft. (assumed saturated)

Only in cases where the Designer considers the soil types at the specific site location to be of lesser strength properties should an analysis be required. Auger borings, SPT borings or CPT soundings may be utilized as needed to verify the assumed soil properties, and at relatively uniform sites, a single boring or sounding may cover several foundations. Borings in the area that were performed for other purposes may be used to confirm the assumed soil properties.

PULL BOX NOTES

1. Fabricated pullboxes from ASTM A 36 steel and hot-dip galvanized in accordance with ASTM A 123 after fabrication. All seams shall be continuously welded and ground smooth. Provide watertight cover with neoprene gasket and secure cover with galvanized screws.
2. Completed pullbox and conduit risers are incidental to the cost of concrete barrier wall.

NOTES

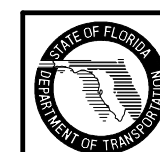

2010 FDOT Design Standards

STANDARD ALUMINUM LIGHTING

Last Revision

07/01/09

Sheet No.

2 of 8

Index No.

17515

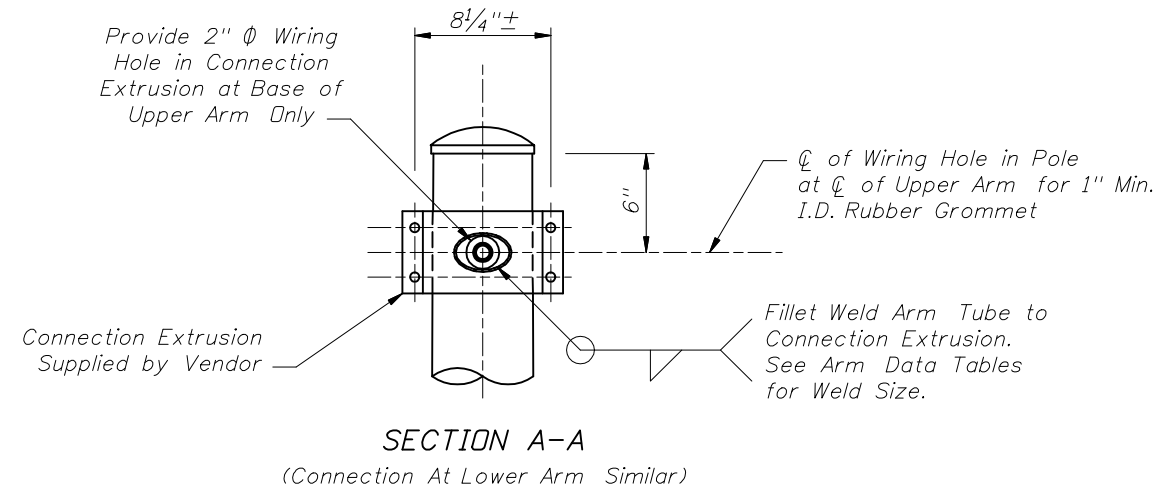
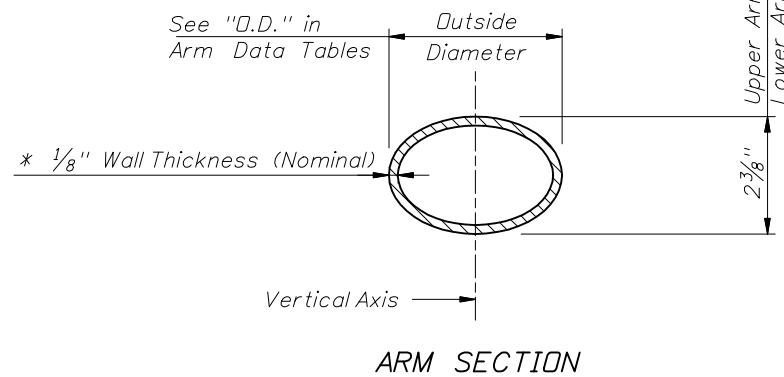
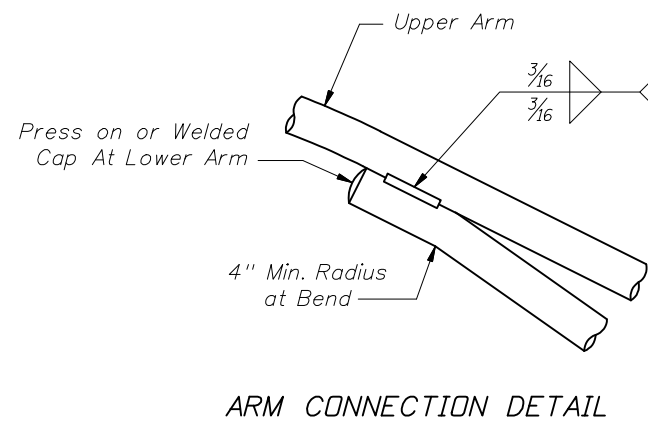

ARM TUBE EXTRUSIONS NOTES:

At the pole connections, provide arm tube extrusions with dimensions as shown in the ARM SECTION and as tabulated in the ARM DATA Tables. Uniformly transition elliptical section to a cylindrical section at the arm connection.

The fabricator may substitute elliptical cross sections other than those tabulated, provided the section properties about the vertical axis and the area of the section equal or exceed that of the required section, and provide minimum wall thickness of 1/8" nominal and within the Aluminum Association Tolerances.

The outside diameter about the minor axis should be held at 2 3/8" at the upper and lower arms.

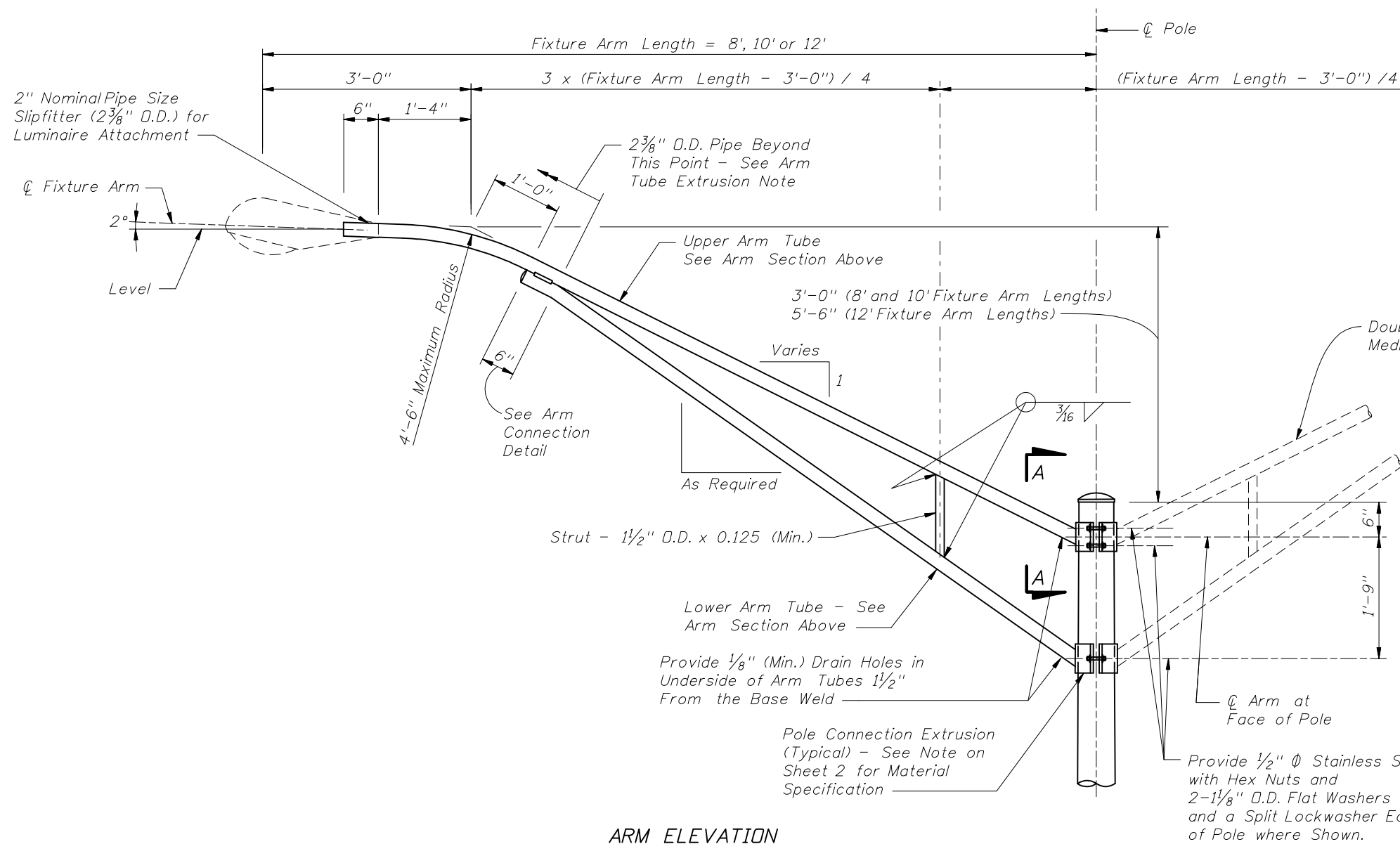

ARM TABLE					
WIND SPEED (MPH)	ARM LENGTH (FT)	UPPER ARM		LOWER ARM	
		O.D. (IN)	WELD (IN)	O.D. (IN)	WELD (IN)
110	8	2.38	0.188	2.38	0.188
110	10 & 12	3.63	0.188	3.63	0.188
110	15	4.63	0.188	4.63	0.188
130	8 & 10	3.63	0.188	3.63	0.188
130	12	4.63	0.188	4.63	0.188
130	15	4.63	0.25	4.63	0.25
150	8	3.63	0.188	3.63	0.188
150	10	3.63	0.250	3.63	0.250
150	12	4.63	0.250	4.63	0.250
150	15	4.63	0.313	4.63	0.313

* Increase Member Wall Thickness as Necessary to Meet Minimum Requirements of the Welding Code for the Connection Weld Sizes Shown in the Arm and Pole Tables.

ARM ELEVATION

ARM DETAILS

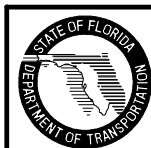

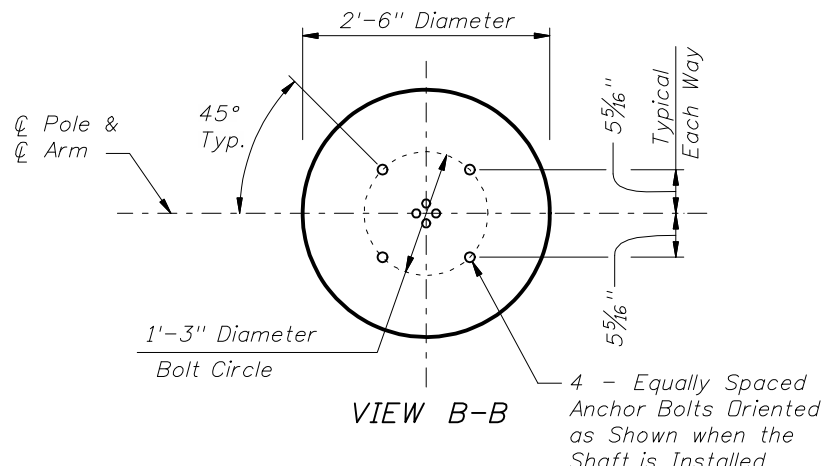
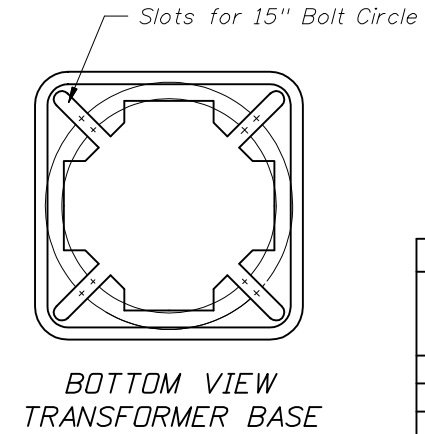
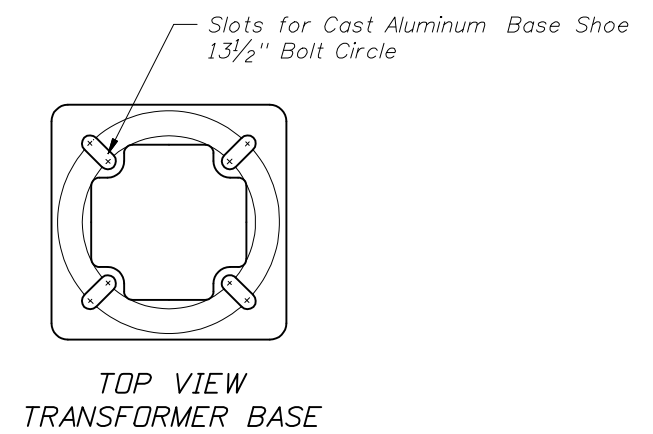
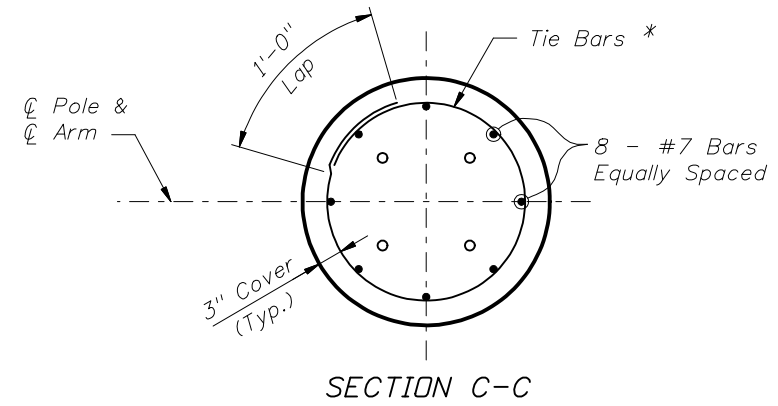

Cast Aluminum Pressure Mounted Nut Cover - Bolted Attachment Optional

Fillet Weld Outside of Pole to Inside of Base Shoe. See Pole Data Tables for Upper Weld Size.

WIND SPEED (MPH)	ARM LENGTH (FT)	DESIGN MOUNTING HEIGHT (FT)	POLE WALL (IN)	UPPER WELD (IN)	LOWER WELD (IN)
110	8, 10, 12 & 15	40 & 45	0.156	0.156	0.156
110	8, 10, 12 & 15	50	0.188	0.188	0.188
130	8, 10 & 12	40	0.156	0.156	0.156
130	15	40	0.188	0.188	0.188
130	8, 10, & 12	45	0.188	0.188	0.188
130	15	45	0.250	0.250	0.250
130	8, 10, 12 & 15	50	0.250	0.250	0.250
150	8, 10, & 12	40	0.188	0.188	0.188
150	15	40	0.250	0.250	0.250
150	8, 10, 12 & 15	45	0.250	0.250	0.250
150	8, 10, 12 & 15	50	0.313	0.313	0.313

NOTE:
Pole wall thicknesses shown in the POLE TABLE are nominals and shall be within the Aluminum Association Tolerances. Thicker walls are permitted and tapered walls may be used provided the minimum Aluminum Association thicknesses are not violated.

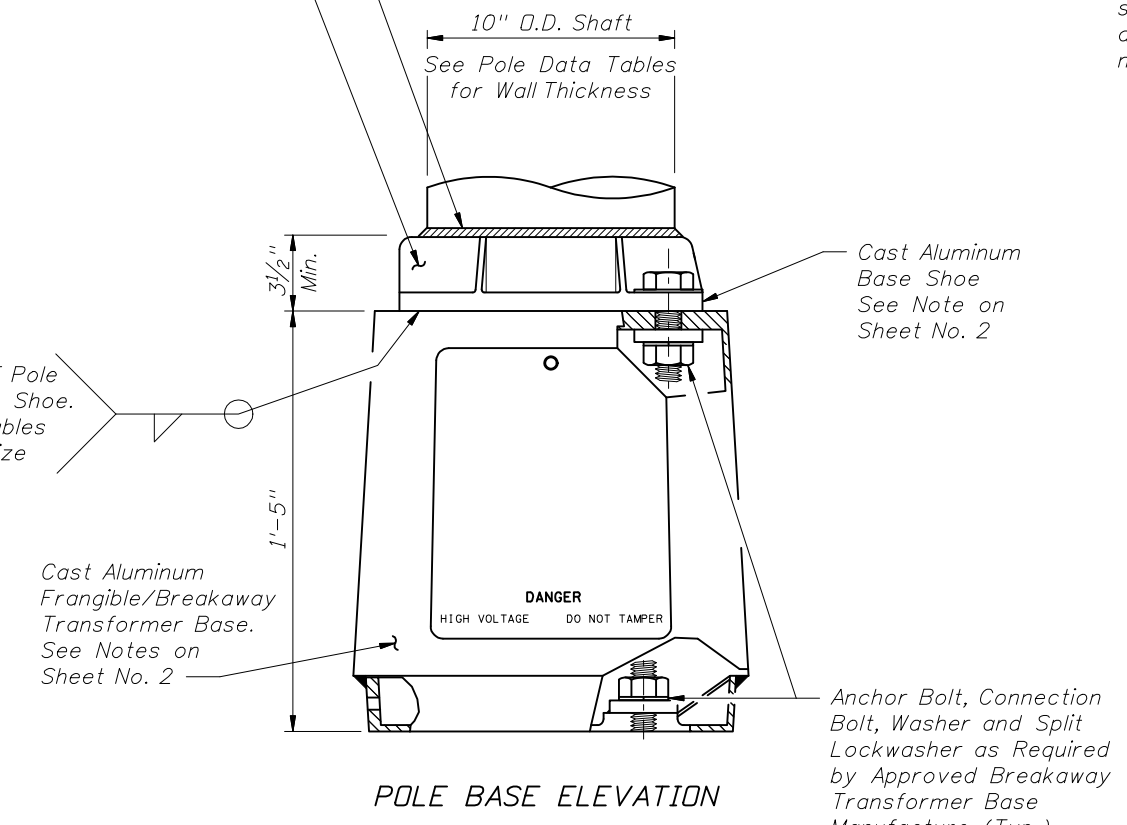

WIND SPEED (MPH)	DESIGN MOUNTING HEIGHT (FT)	TOTAL DEPTH (FT) **
110	40	7
110	45 & 50	8
130	40 & 45	8
130	50	9
150	40 & 45	9
150	50	10

** Depths shown in table are for grades flatter than 1:4, for grades up to 1:2 add 2'-6" to foundation depths shown in table.

- * 1. Shop-weld assemblies of foundation stirrup reinforcing bars are permitted in reinforced concrete foundation provided that:
- The reinforcing bars conform to ASTM Specification A706/706M.
 - The holding wires conform to ASTM Specification A82 or A496.
 - The Shop welding is performed by machines under a continuous, controlled process, approved by the Engineer.
 - Quality control tests are performed on shop-welded specimens and the test results are available, upon request, to the Engineer.
2. #4 Tie Bars @ 12" centers (max.) or D10 (or W10) spiral @ 6" pitch, 3 flat turns top and 1 flat turn bottom.

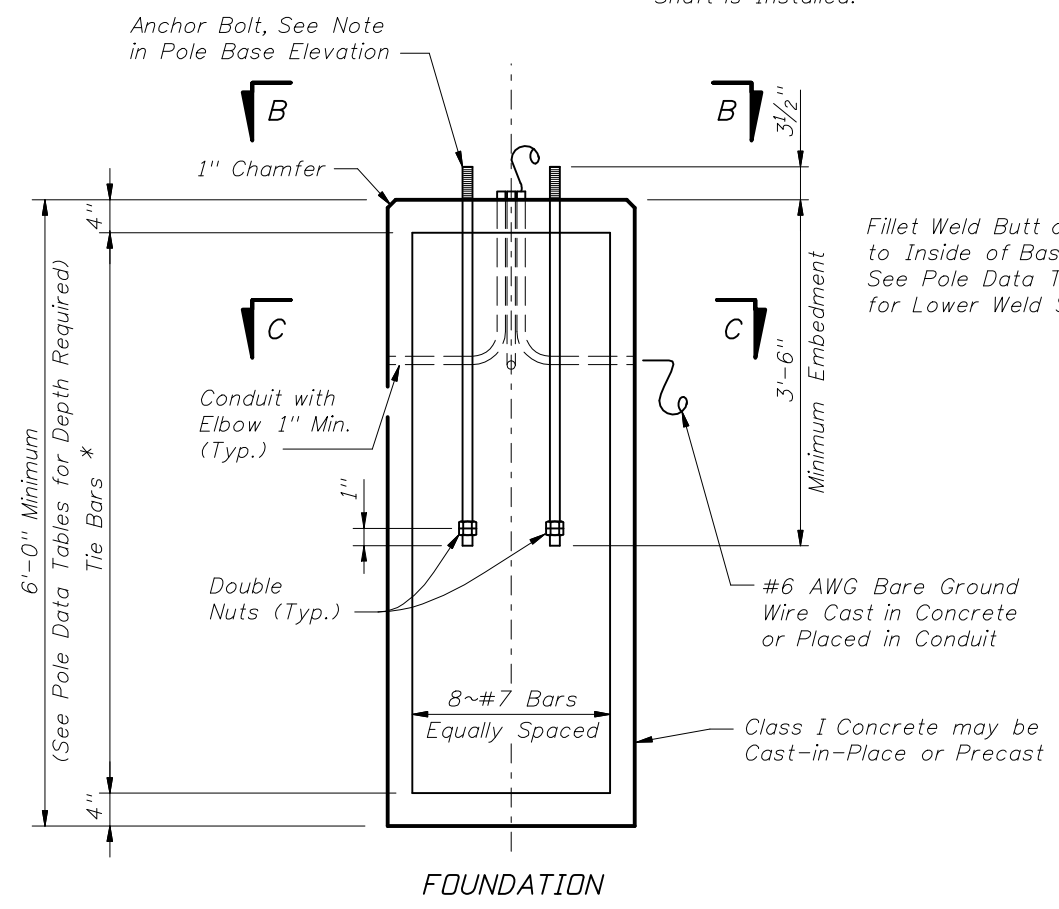

BASE DETAILS FOR ROADWAY ALUMINUM LIGHT POLE



2010 FDOT Design Standards

STANDARD ALUMINUM LIGHTING

Last Revision 07/01/09
Sheet No. 4 of 8
Index No. 17515

POLE TABLE				
WIND SPEED (MPH)	ARM LENGTH (FT)	DESIGN MOUNTING HEIGHT (FT)	POLE WALL (IN)	FILL HEIGHT (FT)
110	8, 10, 12	40	0.25	Up to 70'
130	8, 10, 12	40	0.25	Up to 70'
150	8, 10, 12	40	0.25	Up to 20'
150	8, 10, 12	40	0.313	>20' to 70'

NOTE:
Pole wall thicknesses shown in the POLE TABLE are nominals and shall be within the Aluminum Association Tolerances. Thicker walls are permitted and tapered walls may be used provided the minimum Aluminum Association thicknesses are not violated.

NOTE:
For locations of Bearing Plates, Base Plates and Detail 'A' see Sheets 6 & 7.

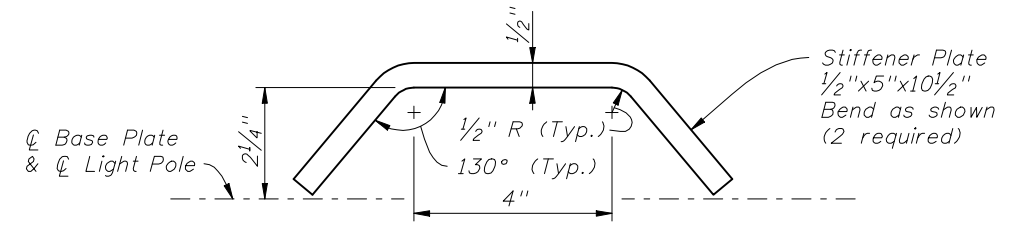

STIFFENER PLATE DETAIL

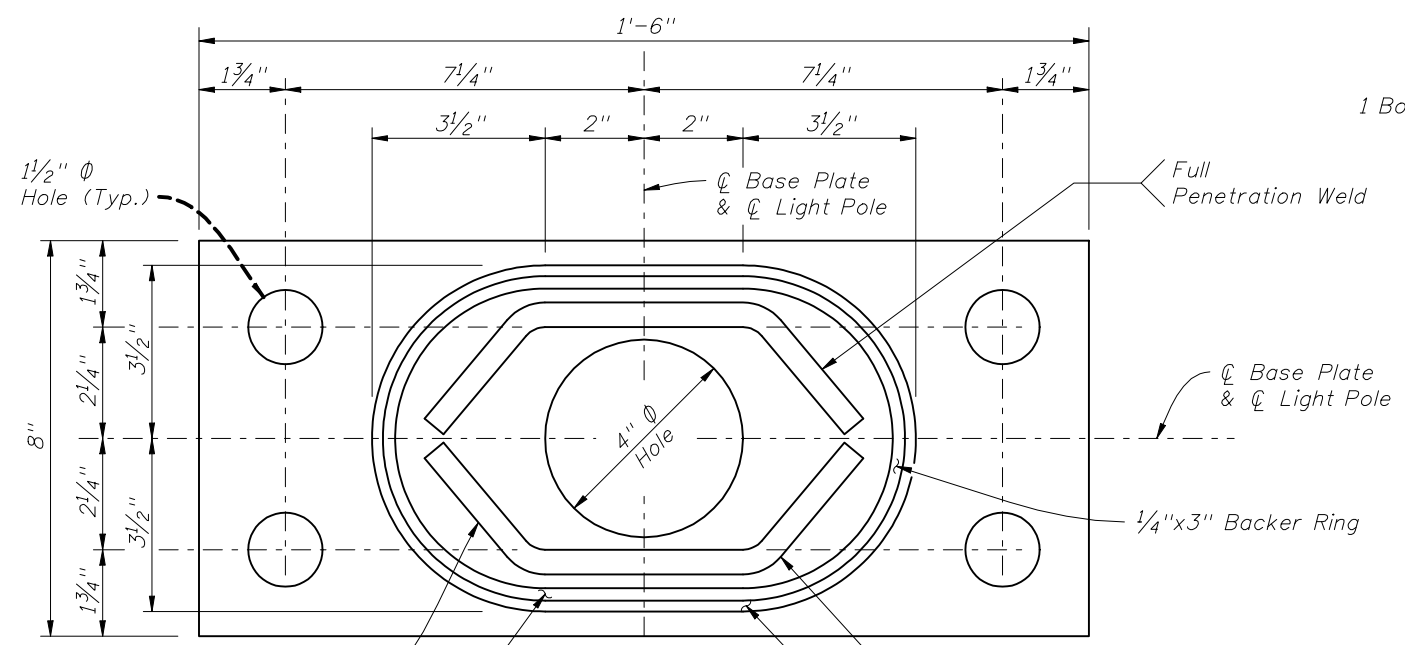

BASE PLATE PLAN

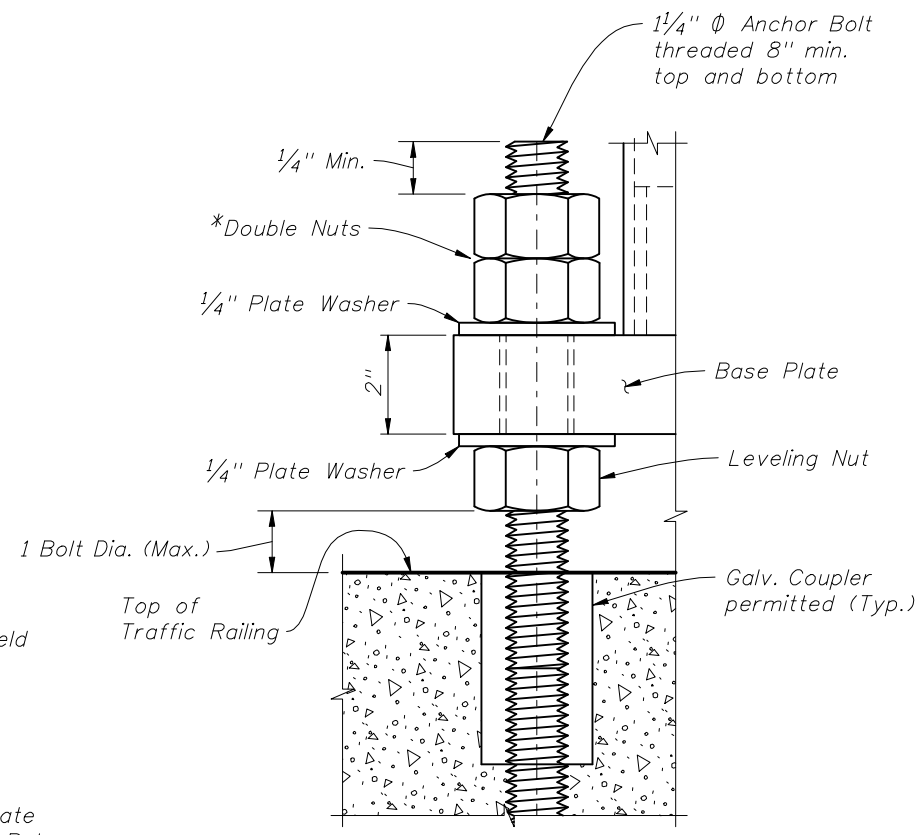

DETAIL 'A'

*Top nut may be 1/2 height Jam Nut. Provide individual nut cover (not shown) for each bolt.

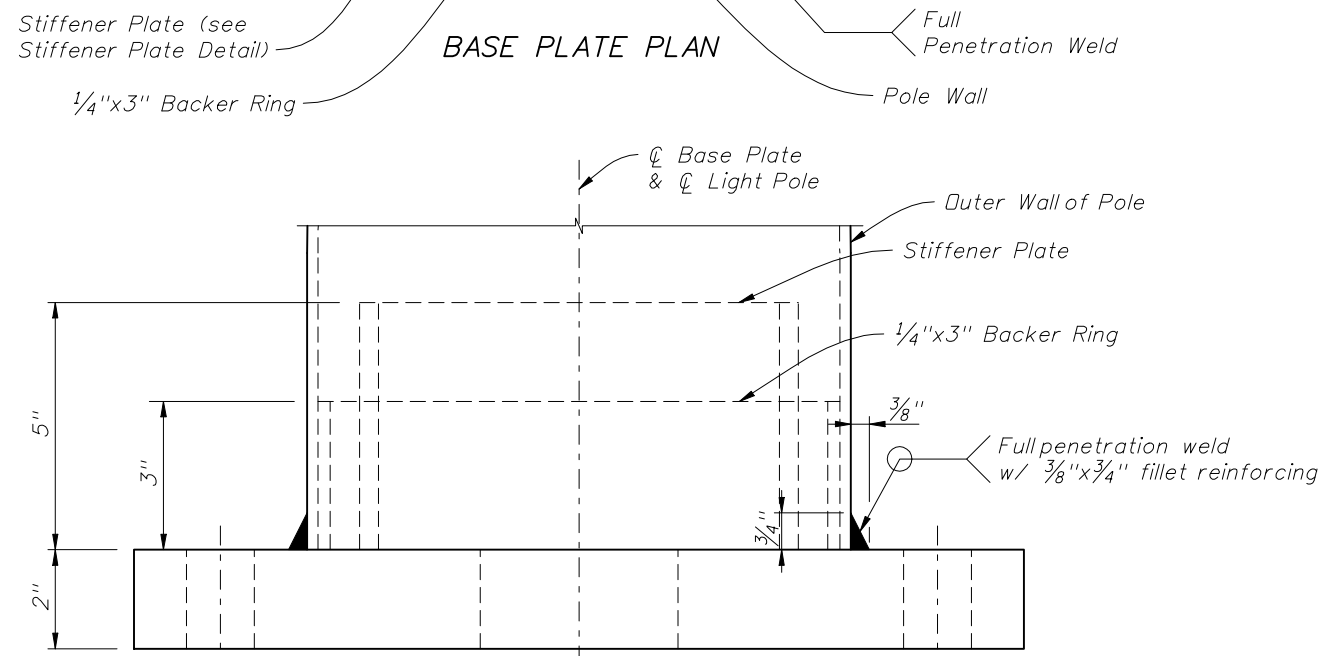

BASE PLATE ELEVATION

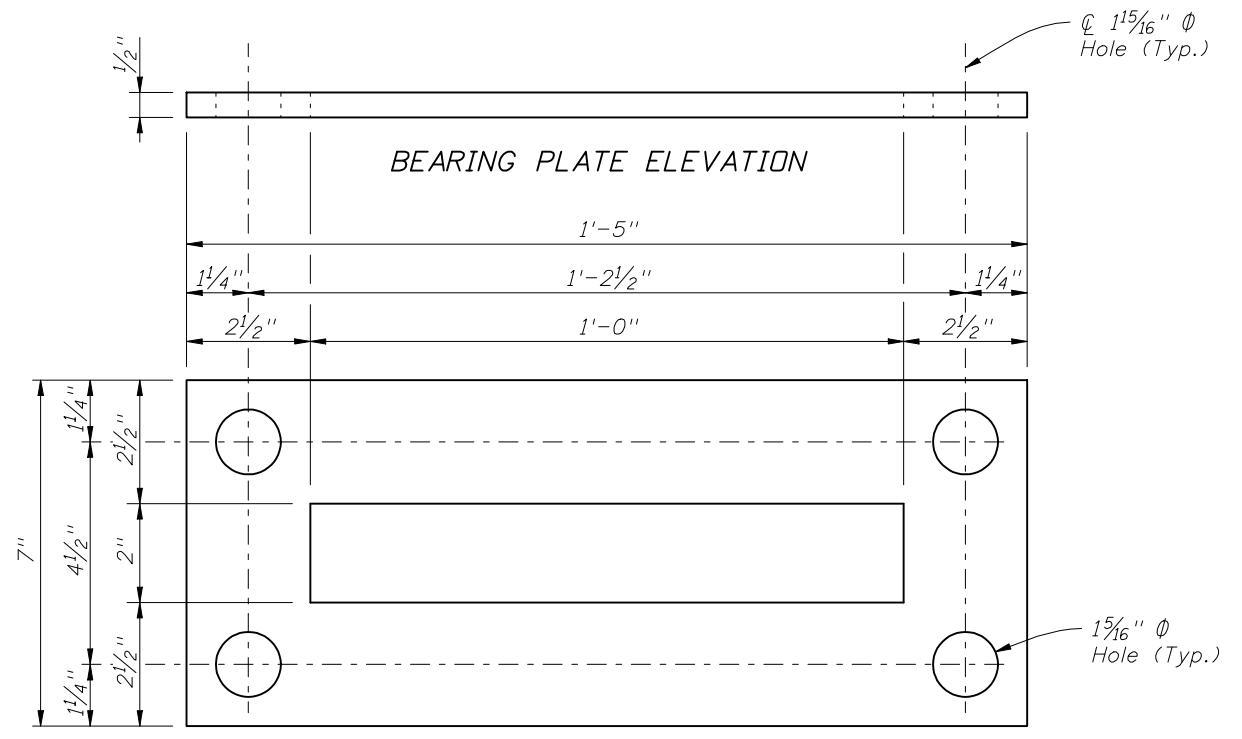

BEARING PLATE ELEVATION

BEARING PLATE PLAN

BASE PLATE DETAILS FOR MEDIAN BARRIER MOUNTED ALUMINUM LIGHT POLE

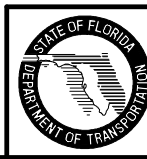

2010 FDOT Design Standards

STANDARD ALUMINUM LIGHTING

Last Revision 07/01/09
Sheet No. 5 of 8
Index No. 17515

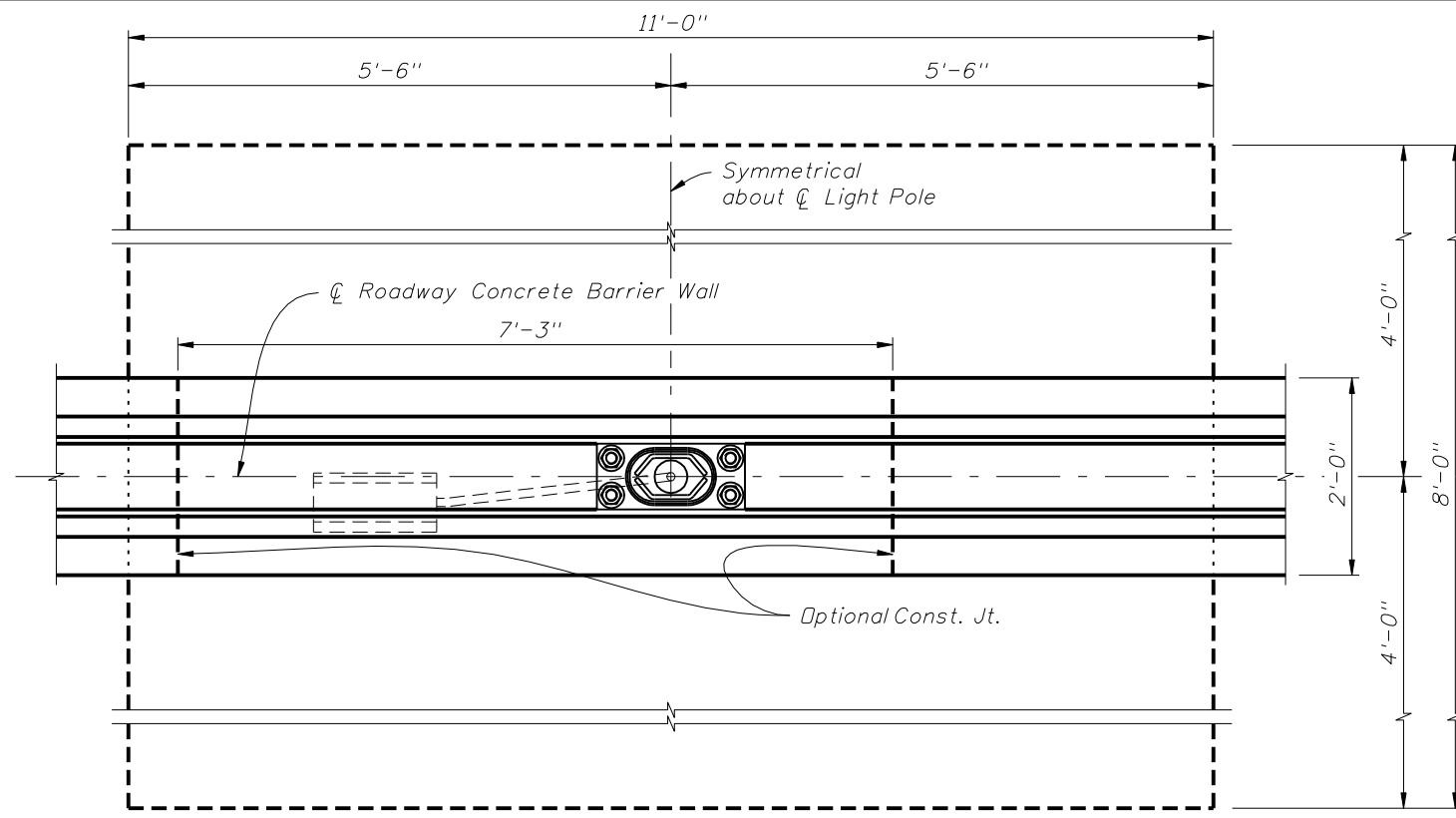

Provide dowel bars @ construction joint
PLAN
 (Reinforcing steel not shown)

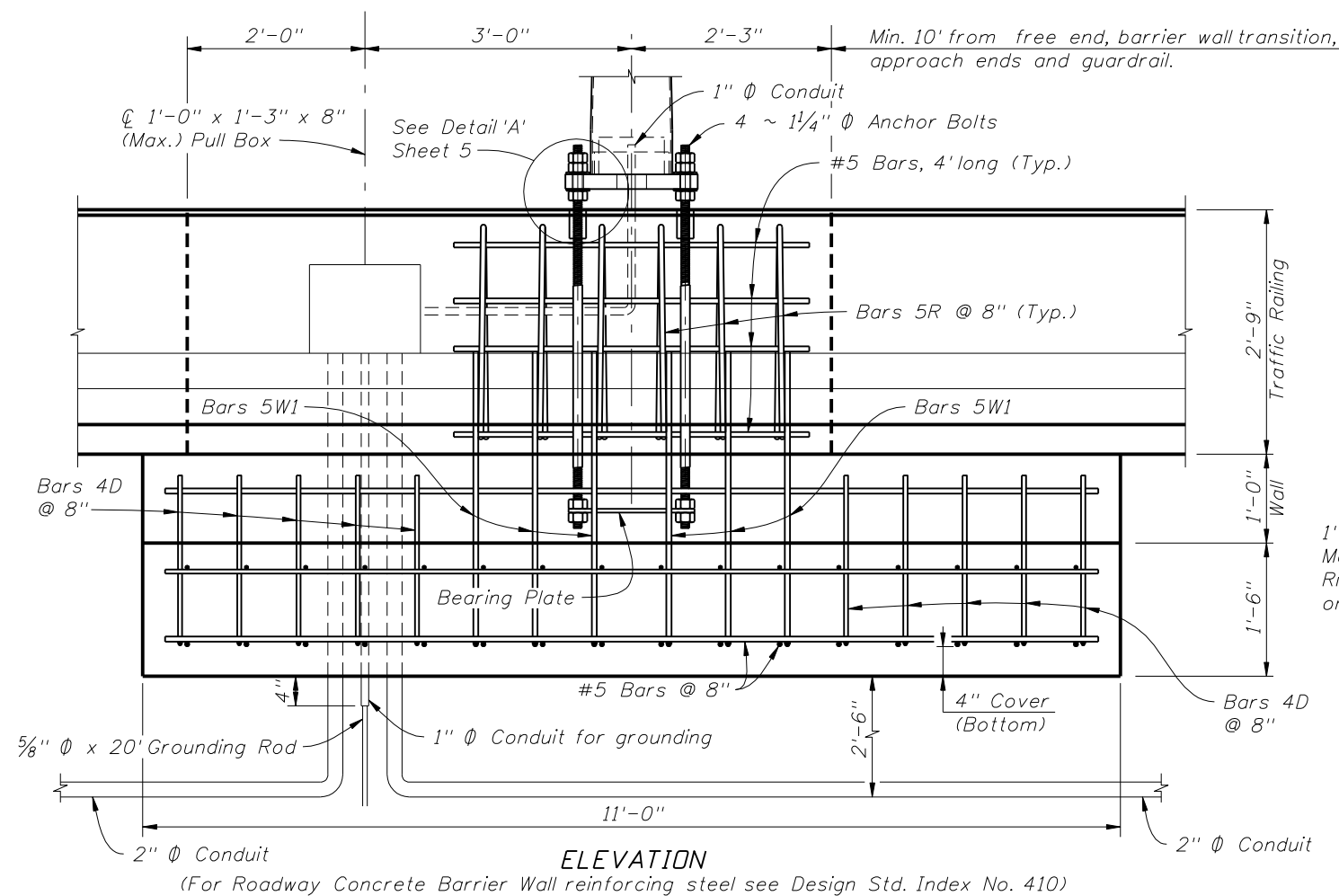

ELEVATION
 (For Roadway Concrete Barrier Wall reinforcing steel see Design Std. Index No. 410)

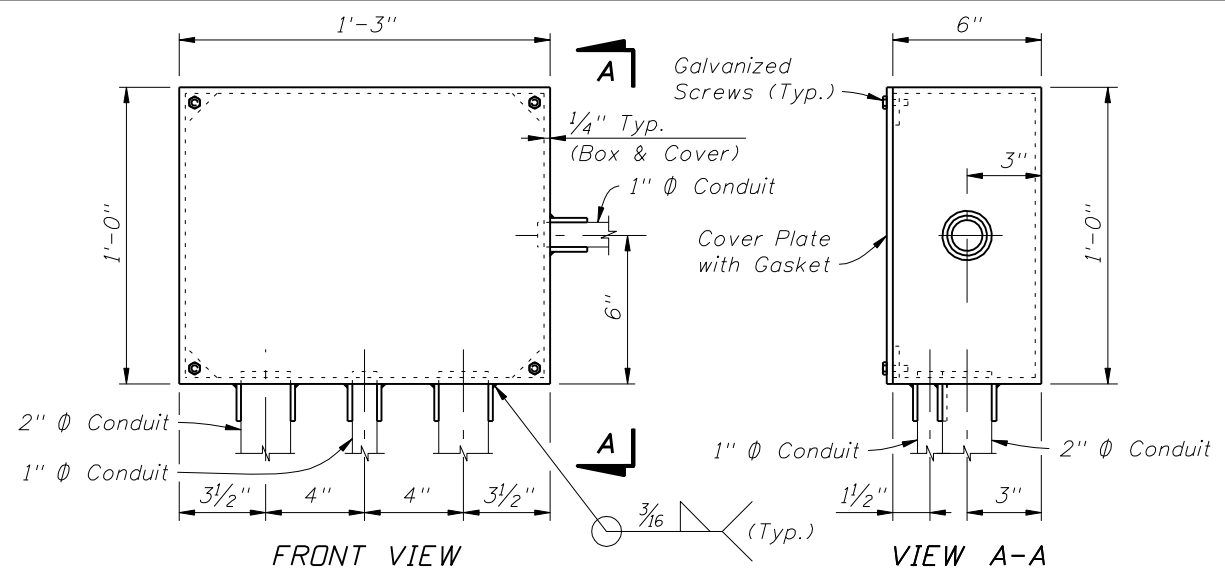

PULL BOX DETAILS

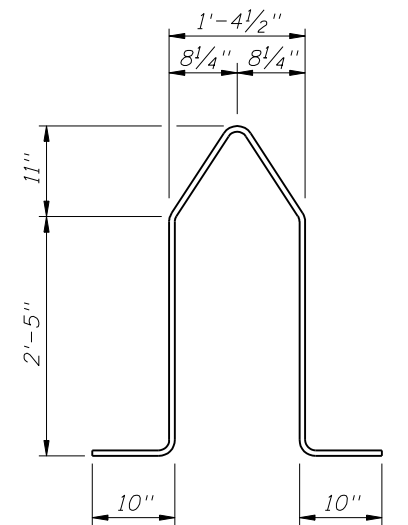

BAR BENDING DIAGRAMS
 BARS 5W1

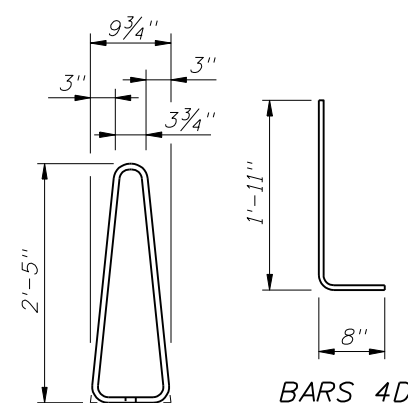

BAR BENDING DIAGRAMS
 BARS 4D

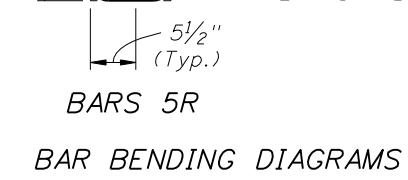

BAR BENDING DIAGRAMS
 BARS 5R

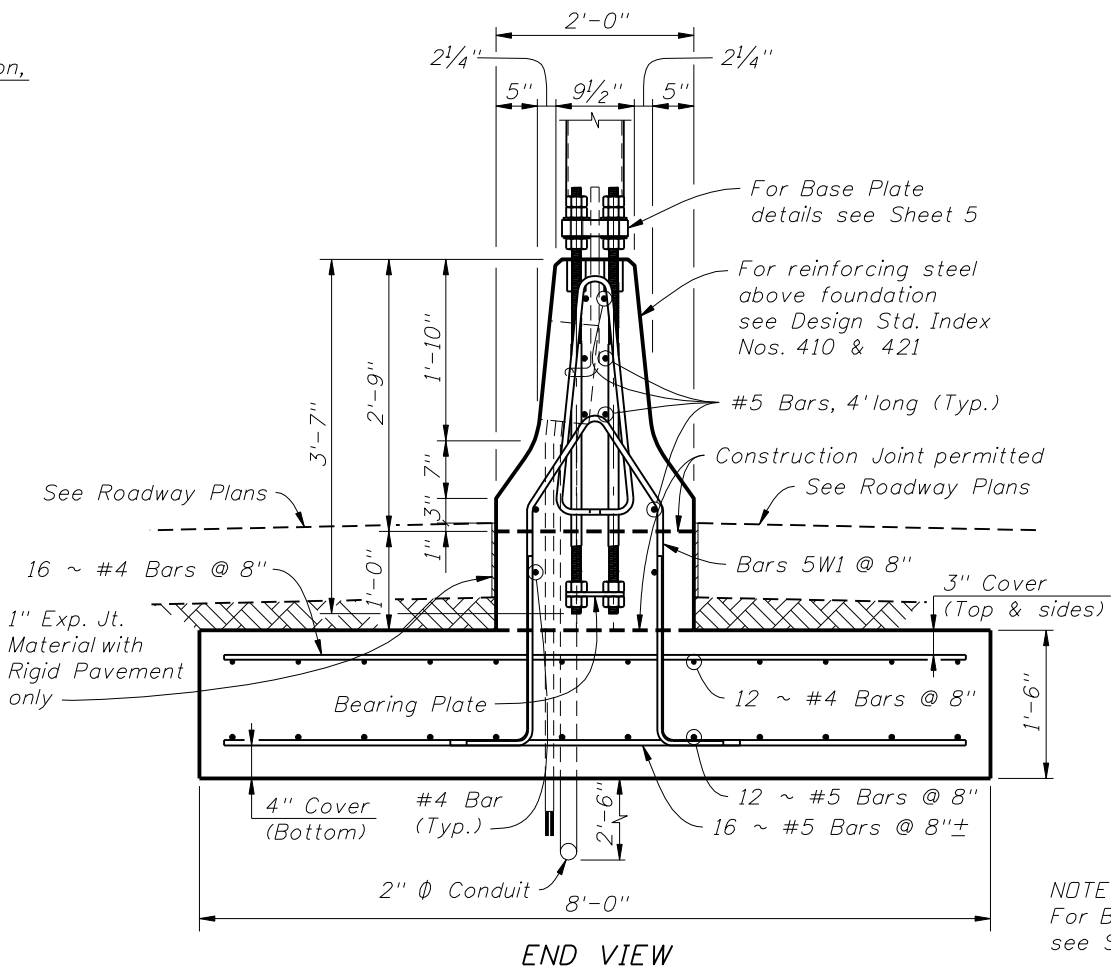

END VIEW

SPREAD FOOTING DETAILS FOR MEDIAN BARRIER MOUNTED ALUMINUM LIGHT POLE

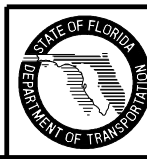

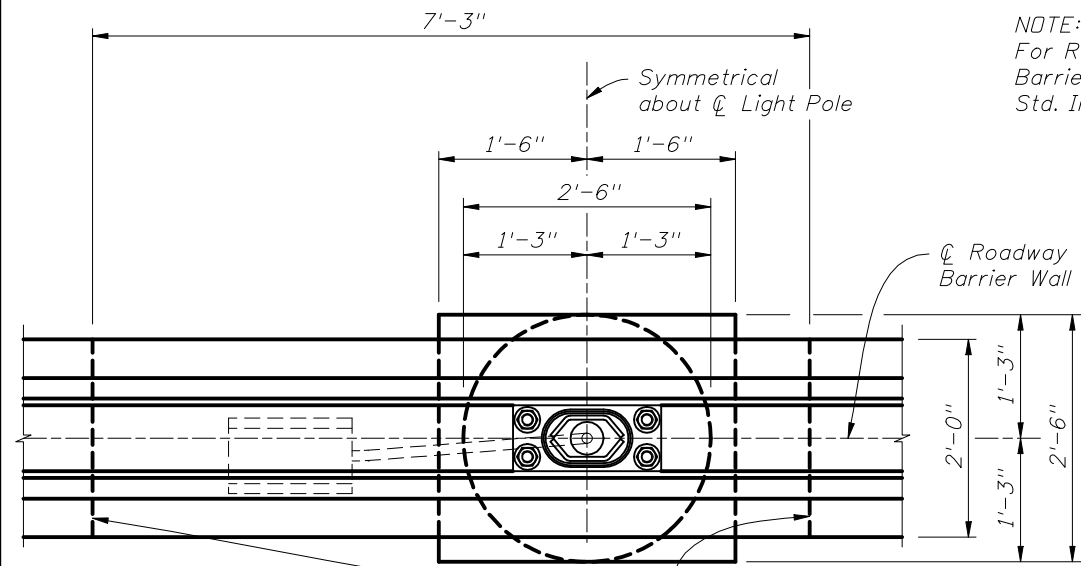

PLAN
(Reinforcing steel not shown)
Provide dowelbars @ construction joint

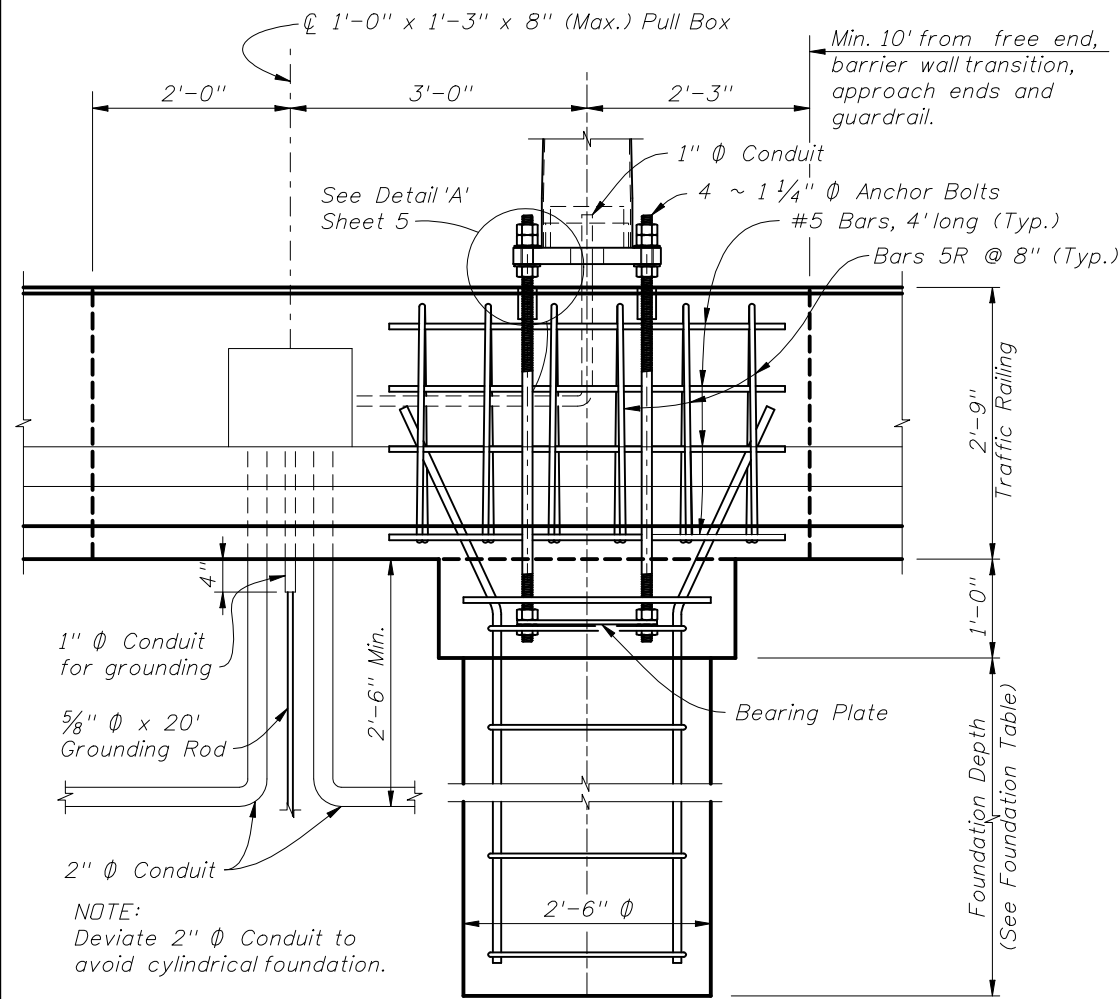

ELEVATION

(For Roadway Concrete Barrier Wall reinforcing steel see Design Std. Index No. 410)

NOTE:
For Roadway Concrete Barrier Wall see Design Std. Index 410

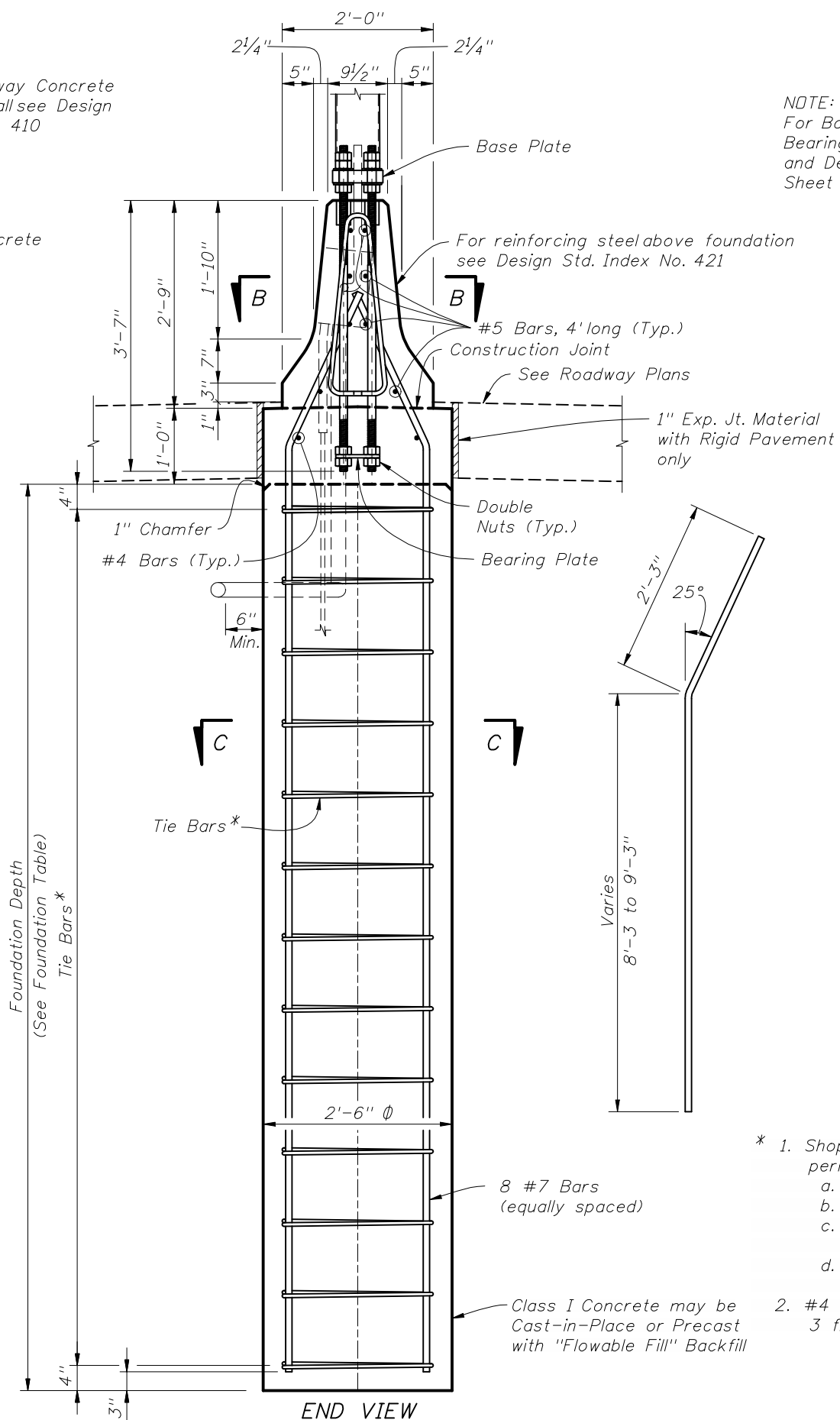

END VIEW

CYLINDRICAL FOUNDATION DETAILS FOR MEDIAN BARRIER MOUNTED ALUMINUM LIGHT POLE

FOUNDATION TABLE		
WIND SPEED (MPH)	DESIGN MOUNTING HEIGHT (FT)	FOUNDATION DEPTH (FT)
110	40	8
130	40	9
150	40	9

NOTE:
For Base Plate Details, Bearing Plate Detail and Detail 'A' see Sheet 5

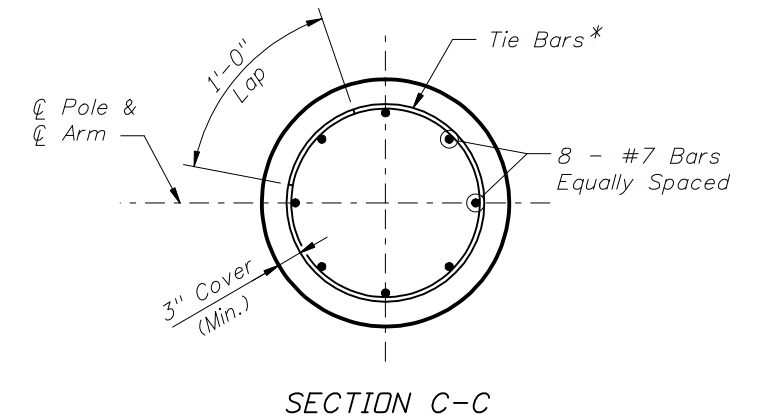
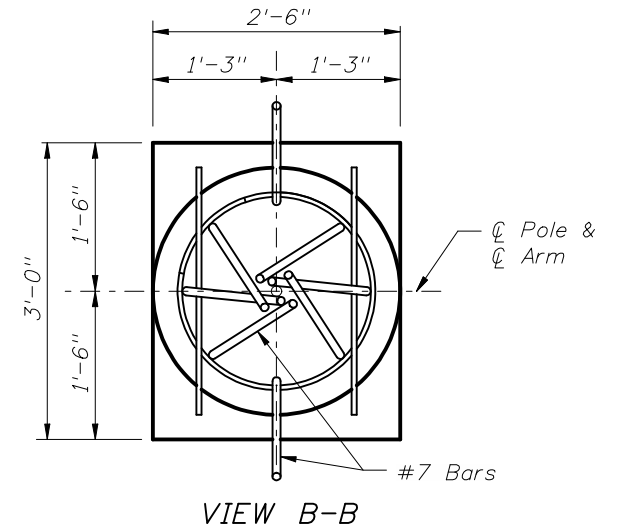

- * 1. Shop-weld assemblies of foundation stirrup reinforcing bars are permitted in reinforced concrete foundation provided that:
- The reinforcing bars conform to ASTM Specification A706/706M.
 - The holding wires conform to ASTM Specification A82 or A496.
 - The Shop welding is performed by machines under a continuous, controlled process, approved by the Engineer.
 - Quality control tests are performed on shop-welded specimens and the test results are available, upon request, to the Engineer.
2. #4 Tie Bars @ 12" centers (max.) or D10 (or W10) spiral @ 6" pitch, 3 flat turns top and 1 flat turn bottom.



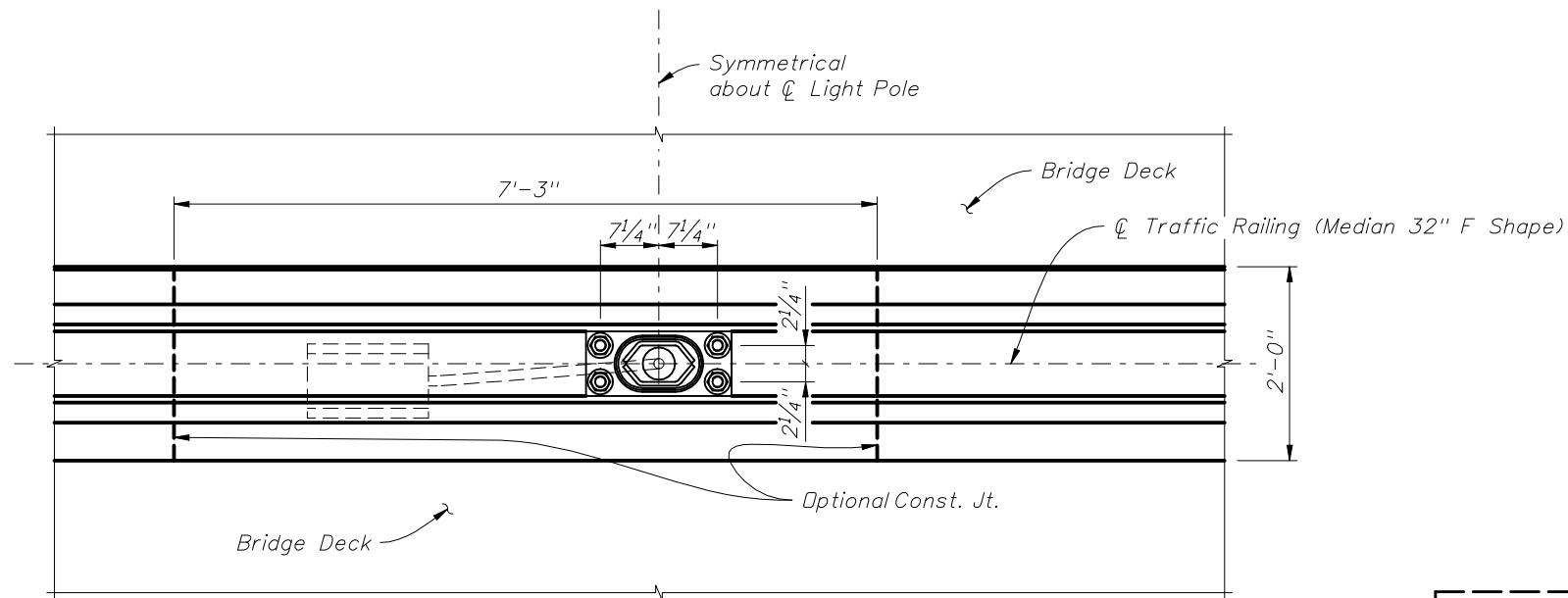

PLAN
(Reinforcing steel not shown)

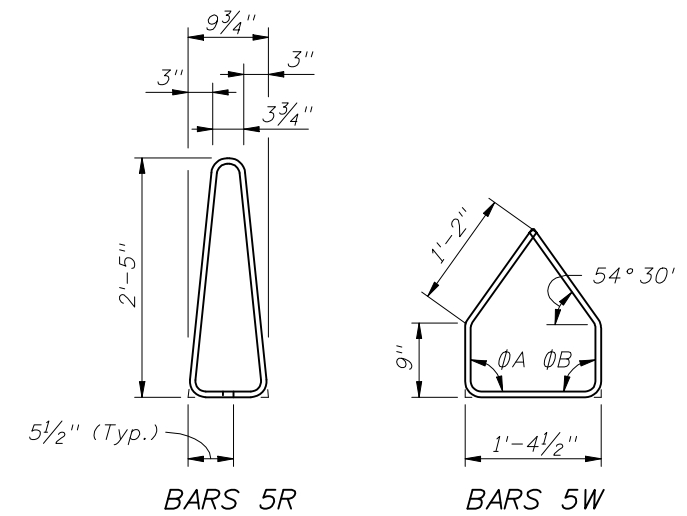

BARS 5R **BARS 5W**

BAR BENDING DIAGRAMS

INSTRUCTIONS TO DESIGNER:
In order to minimize vibration of light poles due to traffic, locate light poles near substructure supports.

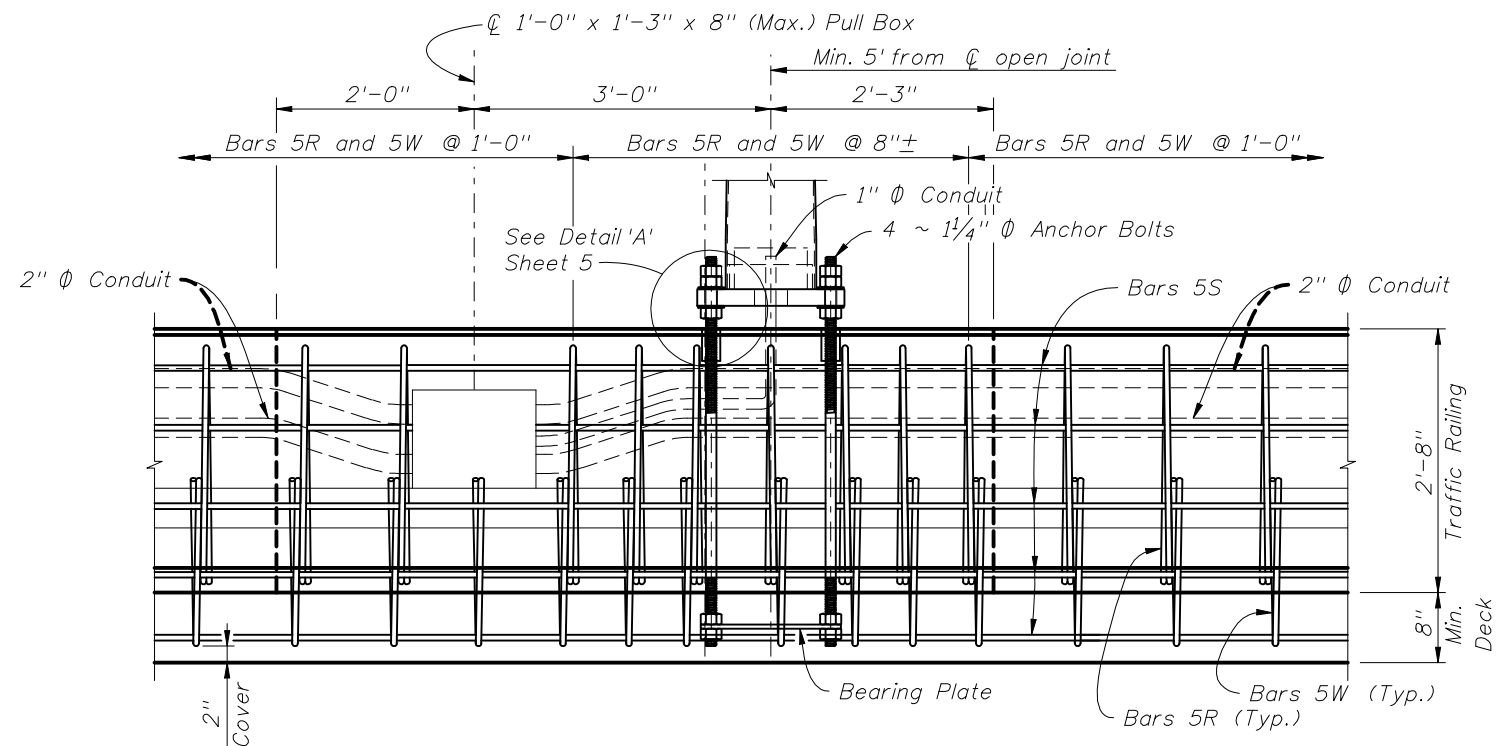

ELEVATION
(Longitudinal and transverse deck reinforcing steel not shown)

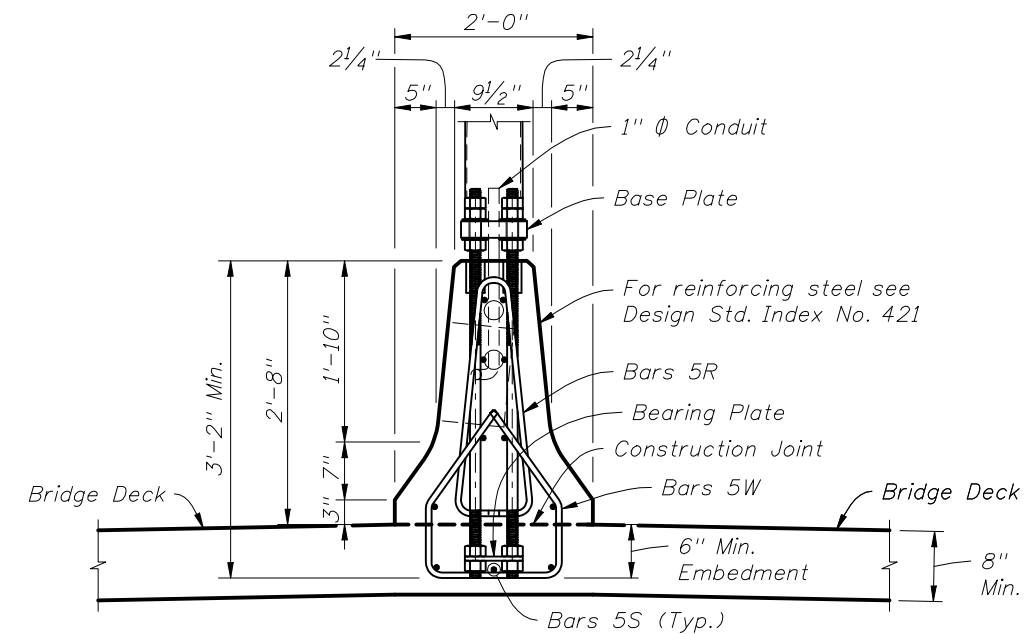

END VIEW
(Longitudinal and transverse deck reinforcing steel not shown)

- NOTES:**
1. For Base Plate Details, Bearing Plate Details and Detail 'A' see sheet 5.
 2. See Design Standard Index No. 421 for details of Traffic Railing (Median 32" F Shape) and angles ΦA and ΦB .

DETAILS FOR TRAFFIC RAILING (MEDIAN 32" F SHAPE) MOUNTED ALUMINUM LIGHT POLE