



# Florida Department of Transportation

JEB BUSH  
GOVERNOR

605 Suwannee Street  
Tallahassee, FL 32399-0450

DENVER J. STUTLER, JR.  
SECRETARY

August 17, 2006

TO: District Directors of Operations, District Directors of Production, District Design Engineers, District Structures and Facilities Engineers, District Geotechnical Engineers, District Maintenance Engineers, District Construction Engineers, District Structures Design Engineers, District Materials Engineers

FROM: William Nickas, P.E., State Structures Design Engineer

COPIES: Ananth Prasad, Bob Greer, Jeffrey Ger (FHWA), David O'Hagan, Brian Blanchard, David Sadler, Duane Brautigam, Robert Robertson, Andre Pavlov, Larry Jones, Larry Sessions, Henry Bollmann, Marc Ansley, Dale Cook

SUBJECT: Temporary Design Bulletin C06-07  
Design Criteria for Pedestrian Bridges including General Use Pedestrian Bridge Permit Requirements.

This Design Bulletin sets the Department's policies and procedures for the Design, Detailing, and Fabrication of pedestrian bridges. The policies and procedures will be integrated into the Department's Structures Plans Preparation Manual, Structures Manual and the standard language for permits.

## REQUIREMENT

**Delete Item 10 "AASHTO Guide Specifications for Design of Pedestrian Bridges" from Section 8.2 of the PPM.**

**Add the following references to Section 8.2 (References) of the PPM (Volume I)**

1. American Association of State Highway and Transportation Officials (AASHTO) "LRFD Bridge Design Specifications", Current Adopted Edition.
2. Florida Department of Transportation "Structures Manual", Current Edition.
3. Florida Department of Transportation "Design Standards", Current Edition.

**Delete Section 8.7 in the Plans Preparation Manual and replace with the following:**

A pedestrian bridge may be necessary to provide pedestrian/bicycle continuity to sidewalks and shared use paths.

Pedestrian bridges shall be designed, detailed, fabricated, and constructed to the requirements outlined in the Structure's Design Manual.

See Chapter 26 for review requirements based on pedestrian bridge structure category.

Pedestrian underpasses are generally undesirable; however, if one is required, the geometrics and lighting requirements should be discussed with the Department Project Manager and the District Pedestrian/Bicycle Coordinator. Local law enforcement personnel may need to be consulted to assure public safety, emergency accessibility and other desirable features.

**Delete Structures Design Guidelines Section 2.13 Pedestrian Bridges**  
**Add Structures Design Guidelines Chapter 10**

**Chapter 10 – Pedestrian Bridges**

**10.1 General**

The criteria covers engineered steel and concrete pedestrian bridge superstructures, including proprietary trusses, and the associated substructures, ramps, stairs, etc. crossing over FDOT roadway or placed on FDOT right of way.

Minor timber structures associated with docks or fishing pier projects are not covered by these policies except that the loading shall meet requirements defined herein. Wooden trusses or timber beam structures may not cross over FDOT roadway facilities.

Plastic, carbon fiber, or fiberglass pedestrian bridges are not allowed.

**10.2 Referenced Standards**

Reference Standards are in accordance with Section 8.2 of the PPM (Volume I).

**10.3 Design**

- A. Design all engineered and proprietary pedestrian bridge structures in accordance with the AASHTO LRFD Bridge Design Specifications, the FDOT Plans Preparation Manual, and the FDOT Structures Design Manual.
- B. All pedestrian bridges shall be:
  - 1) Fully designed and detailed in the plans.
  - 2) Non-proprietary generic designs.(See Section 10.19 for contractor options).
  - 3) Designed for a 75-year design life.
- C. The minimum clear width on new FDOT pedestrian bridges is as follows:
  - 1) The minimum clear width on a pedestrian structure is 8 feet.

- 2) The minimum clear width on shared use path structure is 12 feet.
  - 3) If the approach sidewalk or path is wider than these minimums, the clear width of the structure should match the approach width. The desirable clear width should include additional 2-foot wide clear area on each side.
- D. Load Combinations as per AASHTO LRFD Specifications.
- E. All Design Calculations and Design Details or any Design Changes must be signed and sealed by a Professional Engineer licensed in the State of Florida.
- F. For FDOT projects, engineering design firms working directly for the FDOT or designing a Contractor initiated proprietary pedestrian bridge span option shall be pre-qualified in accordance with Rule 14-75.
- G. Engineering firms designing private permitted bridges that cross FDOT roadway facilities do not have to be pre-qualified in accordance with Rule 14-75, but shall meet the minimum personnel and technical experience defined under Rule 14-75.
- H. Vertical clearance criteria shall be as per the current FDOT PPM Volume I Table 2.10.1. Horizontal clearances shall take into affect future widening plans of the roadway below.
- I. Camber DL/LL Deflections – Expand AASHTO LRFD Specification Section 2.5.2.6.2 as follows:
- 1) Pedestrian Load. . . . . Span/500
  - 2) Truck Load. . . . . Span/500
  - 3) Cantilever arms due to service ped live load. . . Cantilever Length/300
  - 4) Horizontal deflection due to lateral wind load. . . . . Span/500
  - 5) The bridge shall be built to match the plan profile grade after all permanent dead load has been applied.

**10.4 Loading**

- A. Pedestrian Live Loading as per AASHTO LRFD Bridge Design Specifications [3.6.1.6].
- B. Pedestrian/bicycle bridges and ramps shall be designed for an occasional single maintenance vehicle load whenever access is possible. If not otherwise specified, the following loads conforming to the AASHTO Standard H-Truck shall be used.
- 1) Clear Deck width from 8ft. to 10ft.                    10,000 lb (H-5 Truck)
  - 2) Clear deck width greater than 10ft.                    20,000 lb (H-10 Truck)
- H-Truck live load shall not be placed in combination with pedestrian live load.

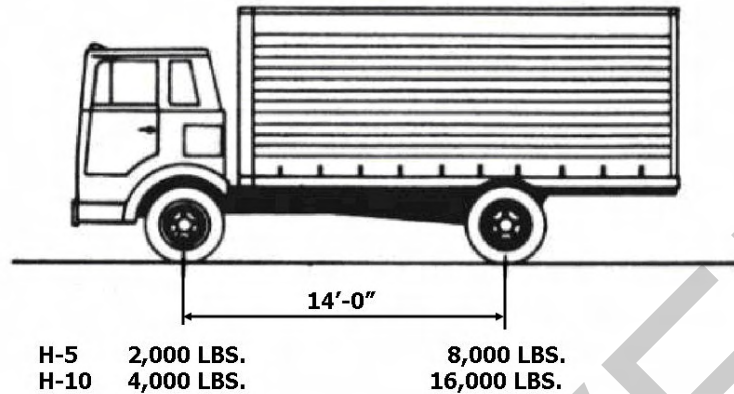

- C. Fatigue loading shall be considered for wind loads.
- D. The structure shall be checked for temporary construction load conditions including checks prior to and during deck casting.
- E. Modify AASHTO LRFD Bridge Design Specifications Section 3.8.1.2 as follows:
- 1) Wind Loads - A wind load of the following intensity shall be applied horizontally at right angles to the longitudinal axis of the structure. The wind load shall be applied to the projected vertical area of all superstructure elements on the leeward truss.
    - 1) For Trusses and Arches: 75 pounds per square foot (90 pounds per square foot for Palm Beach, Broward, Monroe and Dade County)
    - 2) For Girders and Beams: 50 pounds per square foot (60 pounds per square foot for Palm Beach, Broward, Monroe and Dade County)
    - 3) For open truss bridges, where wind can readily pass through the trusses, bridges may be designed for a minimum horizontal load of 35 pounds per square foot (42 pounds per square foot for Palm Beach, Broward, Monroe and Dade County) on the full vertical projected area of the bridge, as if enclosed.
    - 4) Submit wind pressures for bridges over 75 feet high or with unusual structural features, to FDOT for approval.
    - 5) For cable stayed pedestrian bridges, see AASHTO LRFD Bridge Design Specifications Section 3.8.1.2. Increase wind pressures for Palm Beach, Broward, Monroe and Dade Counties by 20 percent.

### 10.5 Materials

- A. The materials shall be in compliance with the applicable FDOT Specifications.
- B. Careful attention shall be given in selecting combinations of metal components that do not promote dissimilar metals corrosion.
- C. Structural Tubing shall meet the requirements of ASTM A500. Minimum thickness of structural steel tubing shall be 1/4" for primary members and 3/16" for verticals and diagonals.
- D. Weathering steel shall not be used unless approved by the Department.
- E. To ensure safety in the design of Steel HSS (Hollow Structural Section), the wall thickness used for design shall be taken as 0.93 times the nominal wall thickness.
- F. Aluminum is allowed only for railing and fence enclosure elements. Isolate aluminum from concrete components at the material interface.
- G. Decks shall be cast-in-place concrete. Concrete cover on decks shall conform to the Florida DOT SDG according to environmental classification. Other restrictions on material based on environment shall also conform to the SDG.

### 10.6 Steel Connections

- A. Field welding is not allowed.
- B. Welding - Meet the requirements of Section 460 of the FDOT Specifications.
- C. Bolting Criteria – All structural field connections shall be bolted with high-strength bolts. High strength bolts, heavy hex nuts, and hardened washers shall conform to the following requirements.
  - 1) Bolted connections shall be designed as per AASHTO, LRFD.
  - 2) Bearing type connections are permitted only for joints subjected to axial compression or on bracing members.
  - 3) Slip-critical bolted connections shall be designed for a Class A surface condition.
  - 4) Use ASTM A325, Type 1, high-strength bolts for all bolted connections. Nuts shall conform to ASTM A563. Washers shall conform to ASTM F436.
- D. Tubular Steel Connections –Field sections shall be bolted together using splice plates. Cap tubular members to ensure structural tubes are fully sealed before field sections are bolted together. All field splices shall be shop fit. Upon completion of fabrication, all tubes shall be fully sealed. Open-ended tubing is not acceptable.
  - 1) Direct Tension Indicators (DTI) are prohibited in bolted connections.
  - 2) Avoid through bolted field sections where possible. When through bolting is necessary, stiffen the tubular section to ensure the shape of the tubular section is retained after final bolting.

### 10.7 Vibrations

- A. The fundamental frequency without live load should be greater than 3.0 hertz (Hz) to avoid the first harmonic. If the fundamental frequency cannot satisfy this limitation, or if the second harmonic is a concern, a dynamic performance evaluation should be made.
- B. In lieu of the above requirement, the bridge may be proportioned so that the fundamental frequency shall be greater than  $f > 2.86 \ln(180/W)$  where “ln” is the natural log and W is the weight (kips) of the supported structure, including dead and live load.
- C. Alternatively, the minimum supported structure weight (W) shall be greater than  $W > 180e^{(-0.35f)}$  where f is the fundamental frequency (Hz).
- D. Check vibration frequency under temporary construction conditions.

### 10.8 Fracture Critical Members

- A. All structural steel tension members shall receive Charpy V-Notch testing in accordance with ASTM A709. Impact testing requirements shall be as noted below:
  - 1) Non-fracture critical tension members shall be tested in accordance with Table 9 (Zone 1) of ASTM A709 (latest version). Primary tension chords in a two truss bridge may be considered non-fracture critical due to frame action. Cross frames, transverse stiffeners, and bearing stiffeners not having bolted attachments and expansion joints do not need to be tested.
  - 2) Fracture critical tension members shall be tested in accordance with Table 10 of ASTM A709 (latest version).

### 10.9 Cable Stay Pedestrian Bridges

- A. Durability – Stay systems shall meet the same protection requirements as FDOT post-tensioning systems for anchors, tendons or P.T. bars.
- B. Design cable-stay structures for stay removal and replacement such that any one stay can be removed.

### 10.10 Painting/Galvanizing

- A. Painting System - Painting shall be in accordance with the Standard Specifications for Road and Bridge Construction, Section 560 and 975. Coatings are not required for the interior of tubular components.
- B. Hot dip galvanizing may be used where entire steel components can be galvanized after fabrication and where project specific aesthetic requirements allow. The design shall consider the suitability of the fabricated component for galvanizing. Galvanizing shall be in accordance with the Standard Specifications for Road and Bridge Construction, Section 962-7. Welding components together after galvanizing is not acceptable. Galvanizers shall be on the Department’s list of qualified plants.

### **10.11 Erection**

- A. The design of pedestrian bridges shall encompass details that minimize the disruption of traffic during bridge erection. Erection over traffic is prohibited. The Contractor's Specialty Engineer is responsible for designing a falsework system capable of supporting portions of the superstructure during erection.
- B. The erection of pedestrian structures shall be inspected per FDOT procedures.

### **10.12 Railings/Enclosures**

- A. Provide pedestrian railings in accordance with AASHTO LRFD with the exception that the clear opening between elements shall be such that a 4.0-in diameter sphere shall not pass through.
- B. Provide ADA compliant handrails as required. Occasional use of the bridge by maintenance or emergency vehicles generally does not warrant the use of a crash tested combination pedestrian / traffic railing.
- C. Provide railings as directed by the District as follows:
  - 1) 42" Pedestrian railing (minimum)
  - 2) 54" Bicycle railing
  - 3) Open top fence / railing combination
  - 4) Full enclosure fence / railing combination
  - 5) Open top cladding / railing combination (glass, steel panel, concrete panel, etc.)
  - 6) Full enclosure cladding / railing combination
- D. Utilize FDOT standard fence designs or connection details from FDOT Design Standards 810, 811, and 812 where applicable.

### **10.13 Drainage**

- A. Provide drainage for the superstructure as required. Provide curbs, drains, pipes, or other means to drain the superstructure pedestrian deck. Drainage of the superstructure onto the underneath roadway is not allowed.
- B. Drainage components shall meet all ADA requirements.

### **10.14 Corrosion Resistant Details**

- A. The design shall employ features throughout with corrosion prevention second only to structural considerations. The design shall anticipate the need for water and debris to quickly dissipate from all surfaces of the structure. Special attention shall be directed toward all aspects of proper materials selection and adherence to proper materials application.

### **10.15 Fabricator Requirements**

- A. Steel Structures
  - 1) Fabricators shall be qualified in accordance with Section 6-8 and Section 460 of the Standard Specifications for Road and Bridge Construction.



- 2) Pedestrian bridge fabricators shall have the AISC Quality Certification for Major Steel Bridges except as follows:  
Pedestrian bridge fabricators shall be AISC Quality Certification for Simple Steel Bridge Structure for pedestrian bridges consisting of un-spliced rolled beams or if fabricating minor bridge components
- B. Concrete Structures
  - 1) Precasters shall be qualified in accordance with Section 6-8 and Section 450 of the Standard Specifications for Road and Bridge Construction.
  - 2) Pedestrian bridge precasters shall be certified by PCI.
- C. All pedestrian bridges will be fully inspected using FDOT inspection procedures for typical steel and concrete structures.

#### **10.16 Ramps**

- A. Ramps (routes with grades > 5%) should be provided at all pedestrian separation structures. When possible, stairways should be provided in addition to ramps. The least possible grade shall be used on a ramp. Maximum grade of ramps shall be 8.33%. Intermediate level platforms 5-ft. long shall be provided at a maximum 30 ft. interval. Additionally, a level platform 5-ft. long at the top and 6-ft. long at the bottom shall be provided.
- B. Provide full-length pedestrian ADA grab handrails on both sides of pedestrian ramps.

#### **10.17 Lighting/Attachments**

- A. Provide lighting levels as per the recommendations of the latest edition of the Illuminating Engineering Society of North America Lighting Handbook (IES). Use the requirements for pedestrian walkways.
- B. For tubular structures, any attachment, including electrical wiring, signs, signals, etc., shall be strapped to the bridge. In no case shall holes be tapped into the tubular members of the structure for attachments.

#### **10.18 Maintenance and Inspection Attachments**

- A. The inspection of pedestrian bridges shall be performed in accordance with the Department's criteria and the FDOT maintenance guidelines. Pedestrian bridges shall be inspected in accordance with all current FDOT procedures.
- B. The inspection and maintenance criteria of private permitted bridges for the spans that cross FDOT roadway facilities are the same as for public bridges.

#### **10.19 Proprietary Structures**

- A. Proprietary structures may be used as Contractor substitutions to designs detailed in the plans. The design, fabrication and erection of these structures shall meet the requirements of this document.
- B. Required Plan Note - Include the following plan notes into all pedestrian bridge Contract Documents. Designers shall also list any project specific restrictions that



must be incorporated into any redesigns or substitutions (Tubes – round or square, span/depth relationships, etc.)

*“The Contractor may propose an alternative proprietary pedestrian bridge from the generic system presented in the Contract Documents. Any Contractor initiated proprietary pedestrian bridge span option shall meet all of the requirements of Chapter 10 of the Structures Design Guidelines and be in compliance with and constructed in accordance with Section 460. Proprietary pedestrian bridges shall meet all project specific restrictions and all aesthetic requirements of the project”.*

*“The Contractor shall submit signed and sealed, calculations, revised plans and fully detailed shop drawings for the proprietary span option to the Engineer for approval. The Contractor may initiate the alternates described herein without following the VECP process. All costs associated with the Contractor proprietary option shall be borne by the Contractor”.*

#### **10.20 Permit Structures**

- A. Only spans(s) crossing FDOT roadway facilities and the supporting piers and foundations will be reviewed by FDOT.
- B. Design, fabrication, and erection of non-FDOT structures placed over FDOT roadways or on FDOT right-of-ways will comply with the requirements of this chapter and Chapter 8 [Section 8.7] of the Plans Preparation Manual (Volume I).

#### **BACKGROUND**

The general policy for pedestrian bridges was initiated in Temporary Design Bulletin C05-06 (Interim Policy for Prefabricated Pedestrian Steel Truss Bridges). The previous policy was intended to address the contractor’s solicitation of proprietary bridges and placing plans from a single vendor into the contract plans. More specifically, the policy mandated that pedestrian bridge facilities (1) be fully designed and detailed in the plans, (2) be designed in compliance with all Department design criteria, (3) use the AASHTO Standard Specs 17<sup>th</sup> edition and the AASHTO Guide Specification for the Design of Pedestrian Bridges, (4) be non-proprietary, and (4) be reviewed by SDO if designed to be steel.

The new policy simply builds upon the previous policy with modifications and establishes requirements for the design, construction, and erection of engineered and proprietary pedestrian bridges crossing FDOT right-of-way.

Proprietary structures crossing FDOT right-of-ways may be sole-sourced only in permit jobs by private owners. Permitted jobs with sole-sourced proprietary structures will be reviewed only for the span(s) crossing FDOT right-of-way and the supporting piers and

foundations. For FDOT jobs, proprietary structures may only be utilized as Contractor substitutions to designs detailed in the plans. In all cases, the design, fabrication and erection of proprietary structures shall meet all Department policies.

The policy also addresses the Quality Assurance/Quality Control (QA/QC) procedures which are in place as required in the Department's Standard Specifications for Road and Bridge Construction for fabrication shops for all pedestrian bridges. Previously, the fabricators may not have had QA/QC procedures approved by the Department. This created an unfair advantage for proprietary designs and for fabricators not qualified by the Department. The new policy now requires qualified fabrication shops, qualification review audits, and quality control plans consistent with the construction specifications.

In addition to qualified fabricators, the new policy also requires pedestrian bridges to be designed by pre-qualified engineers or engineering firms as required by Florida Administrative Rule 14-75.

### **COMMENTARY**

The pedestrian bridge memorandum was developed to ensure that all pedestrian bridges either on or crossing over FDOT right-of-way would be designed, fabricated, and erected within the Department's policies and specifications regardless of whether the structure is a proprietary structure or standard design.

### **IMPLEMENTATION**

This requirement shall be implemented on all FDOT projects beginning with the January 2007 letting and for all permit jobs applied for after September 1, 2006.

### **CONTACT**

Robert Robertson, PE  
Assistant State Structures Design Engineer  
(850) 414-4267  
robert.robertson2@dot.state.fl.us