

# AGENDA

## FLORIDA GREENBOOK ADVISORY COMMITTEE MEETING

Thursday, March 26, 2015, 8:00 AM – 5:00 PM

Friday, March 27, 2015, 8:00 AM – 12:00 PM

FL Highway Patrol-Troop C Headquarters Auditorium  
11305 N. McKinley Drive, Tampa, FL 33612

---

### Thursday, March 26, 2015

#### 8:00 – 8:30 Introductions and General Information

- Welcome and Introductions (Michael Shepard)
- Welcome from FHP, Troop C, Major Michael Thomas (will drop in)
- Committee and Associate Member Changes (Mary Anne Koos)
- March 2014 Meeting Minutes & Vote to Approve (Mary Anne Koos)
- Contact Information and Subcommittee Assignments (Mary Anne Koos)

#### 8:30 – 9:00 Rulemaking and Sunshine Law

- Rulemaking Process (Susan Schwartz, General Counsel's Office)
- Sunshine Law (Susan Schwartz, General Counsel's Office)
- Status of 2013 Greenbook (Susan Schwartz, General Counsel's Office)

#### 9:00 – 9:30 Presentation of Proposed Revisions for 2015 Greenbook

- Chapter 6 – Roadway Lighting (Bernie Masing)
- Chapter 11 – Work Zone Safety (Chris Tavella)

#### 9:30 – 9:45 *Morning Break*

#### 9:45 – 11:30 Presentation of Proposed Revisions for 2015 Greenbook (continued)

- Chapter 8 – Pedestrian Facilities (Annette Brennan)
- Chapter 9 – Bicycle Facilities (Annette Brennan)
- Chapter 15 – Traffic Calming (Steve Neff)

---

#### 11:30 – 1:00 *Lunch*

---

#### 1:00 – 1:15 Orientation for Subcommittee Meetings (Michael Shepard, Mary Anne Koos)

#### 1:15 – 1:30 Move to Breakout Rooms (FHP and FDOT)

#### 1:30 – 2:15 Subcommittee Meetings for Final Drafting of Proposed 2015 Revisions

- Chapter 8 – Pedestrian Facilities (Annette Brennan, Auditorium, FHP)
- Chapter 11 – Work Zone Safety (Chris Tavella, Executive Conference Room, FDOT)
- Chapter 15 – Traffic Calming (Steve Neff, Dolphin Room, FDOT)

- 2:15 – 2:30**     *Afternoon Break*
- 2:30 – 3:30**     **Subcommittee Meetings for Final Drafting of Proposed 2015 Revisions**
- Chapter 6 – Roadway Lighting (Bernie Masing, Dolphin, FDOT)
  - Chapter 9 – Bicycle Facilities (Annette Brennan, Auditorium, FHP)
- 3:30 – 3:45**     **Reconvene in FHP Auditorium**
- 3:45 – 5:00**     **Chapter Report and Vote on 2015 Chapter Revisions**
- Chapter 6 – Roadway Lighting (Bernie Masing)
  - Chapter 8 – Pedestrian Facilities (Annette Brennan)
  - Chapter 9 – Bicycle Facilities (Annette Brennan)
  - Chapter 11 – Work Zone Safety (Chris Tavella)
  - Chapter 15 – Traffic Calming (Steve Neff)
- 5:00**             *Adjourn*

**Friday, March 27, 2015**

- 8:00 – 9:00**     **Future Greenbook Revisions**
- Goals (Michael Shepard)
  - Summary of Major Changes from PPM, Design Bulletins (Paul Hiers)
  - Parking Lot Topic Discussion (Michael Shepard)
  - Selection of Chapters for Future Work (Michael Shepard)
- 9:15 – 9:30**     *Morning Break*
- 9:30 – 10:15**   **Breakout Sessions for Future Greenbook Revisions**
- Chapter \_\_\_\_\_ (Auditorium, FHP )
  - Chapter \_\_\_\_\_ (Auditorium, FHP )
  - Chapter \_\_\_\_\_ (Pelican Room, FDOT)
  - Chapter \_\_\_\_\_ (Tarpon Room, FDOT)
- 10:15 – 10:30**   **Reconvene in FHP Auditorium**
- 10:30 – 11:45**   **Chapter Chair Reports for Future Greenbook Revisions and Discussion**
- 11:45 – 12:00**   **Closing Remarks** (Michael Shepard)
- 12:00**             *Adjourn*

# **Minutes (Approved)**

## **FLORIDA GREENBOOK ADVISORY COMMITTEE MEETING**

**Thursday, March 26, 2015, 8:00 AM – 5:00 PM**

**Friday, March 27, 2015, 8:00 AM – 12:00 PM**

FL Highway Patrol-Troop C Headquarters Auditorium  
11305 N. McKinley Drive, Tampa, FL 33612

---

### **Thursday, March 26, 2015**

#### **Members in Attendance**

Bernie Masing, Ramon D. Gavarrete, Andy Tilton, Steven M. Neff, Nelson Bedenbaugh (for Kathy Thomas), Kenneth Dudley, Gene Howerton, David Cerlanek, John Fowler (for District 3 DDE), Rick Hall, Keith Bryant, Howard Webb, Robert Behar, Christopher R. Mora, George T. Webb, Annette Brennan, Gail Woods, Charles Ramdatt, Richard Baier, Chris Tavella, Andres Garganta, Gaspar Miranda, Richard Moss, Richard Diaz, Peter R. Brett, Margaret Smith

#### **Associate Members in Attendance**

Joy Puerta, Mark V. Massaro, David F. Kuhlman, Frederick J. Schneider

#### **FDOT Staff, Technical Advisors and Public in Attendance**

Duane Brautigam, Michael Shepard, Mary Anne Koos, Paul Hiers, Billy Hattaway, Chester Henson, Fred Heery, DeWayne Carver, George Borchik, Christine Lofye, Kevin Miller.

#### **General Information**

- **Welcome and Introductions (Michael Shepard)**

Florida Greenbook Committee and Associate Member Changes - Changes in membership for the Greenbook Committee were discussed and new members, Richard Baier (Sumter County), Margaret Smith (Pasco County), and Richard Moss (District 7, FDOT) introduced. John Fowler (for Scott Golden, FDOT District 3) and Nelson Bedenbaugh (for Kathy Thomas, FDOT District 2) were also introduced.

- **Review March 2014 Meeting Minutes & Vote to Approve (Mary Anne Koos)**

David Kuhlman requested the minutes be amended regarding the discussion summary from the Work Zone Safety Subcommittee. The minutes were revised to read: "The subcommittee began by discussing MOT schemes for utility operations that may be less stringent than those provided in the FDOT 600 Series Indexes. The proposal was to

replicate criteria for low speed, low volume roads found in the MUTCD.” Howard Webb moved to approve the minutes as revised, seconded by Andy Tilton, approved by the Committee with no further edits.

- **Review Contact Information (Mary Anne Koos)**

The Committee Membership list was circulated for everyone to update their contact information.

- **Update Subcommittee Assignments (Mary Anne Koos)**

The list of current chairs for the chapter subcommittees was reviewed, and chair assignments updated. Members also updated their committee membership preferences.

### **Rulemaking and Sunshine Law**

- **Rulemaking Process (Susan Schwartz, General Counsel’s Office)**

The Rule for the Florida Greenbook is 14-15.002, Florida Administrative Code (F.A.C.). Ms. Schwartz reviewed the "Rulemaking – 2015" presentation included in the meeting materials along with an overview of Florida’s Government in the Sunshine Law.

"Rulemaking" is defined as the adoption, amendment or repeal of a rule and is the process used to adopt the Greenbook. In its simplest form, rulemaking consists of drafting the rule text, providing notice to the public, accepting public comment and filing the rule for adoption. Revisions to the Florida Greenbook begin with drafting proposed changes and review by the Committee. The proposed changes are then reviewed by FDOT’s General Counsel Office and approved by FDOT’s Secretary.

The Greenbook is published first in Rule Development, then in Rule Making. If there are no comments, or if all comments are addressed, it then goes to the Department of State (DOS) for Rule Adoption. Twenty days after it is posted by DOS, the manual becomes effective.

The 2013 Florida Greenbook (Draft) is still in the rulemaking process. FDOT staff are working to resolve concerns expressed by the Legislature’s Joint Administrative Procedures Committee (JAPC).

- **Sunshine Law (Susan Schwartz, General Counsel’s Office)**

To comply with Florida’s Sunshine law, Ms. Schwartz explained that members cannot discuss with each other the action they intend to take at a later meeting of the Greenbook Committee. Subcommittee meetings don’t need to be noticed if the meeting is just for fact finding and the final recommendations come before the full committee for approval. Meetings of the Florida Greenbook and Subcommittees are posted on FDOT’s public meetings web page.

## **Presentation of Proposed Revisions for the 2015 Greenbook**

- **Chapter 6 – Roadway Lighting (Bernie Masing)**

Mr. Masing presented the proposed changes for the chapter, as shown in the draft dated March 23, 2015. These updates include a discussion of lighting bicycle and pedestrian facilities adjacent to roadways, adding a new section “Types of Illumination”, removing the values for freeways from Table 7-1 Level of Illumination for Streets and Highways since freeways will be guided by the Plans Preparation Manual (PPM) criteria, and adding a description of luminance and Table 7-2 Road Surface Conditions. A section on Adaptive Lighting to provide guidance in coastal areas or where lower levels of lighting might be required was added. A new Reference section was added.

- **Chapter 11 – Work Zone Safety (Chris Tavella)**

Mr. Tavella presented the proposed changes for the chapter, as shown in the draft dated March 23, 2015. These updates include expanding the intent to include pedestrians, bicyclists, and motorists and factors which need to be considered when developing a work zone safety plan. The section on Work Zone Management was revised to require that all roadwork operations shall follow a coordinated temporary traffic control plan.

- **Chapter 8 – Pedestrian Facilities (Annette Brennan)**

Ms. Brennan presented the proposed changes for the chapter, as shown in the draft dated March 24, 2015. The types of pedestrian facilities was expanded, minimum sidewalk and utility strip widths revised, preferred location for sidewalks updated, and a requirement to evaluate sidewalk termini added. Criteria for acceptable running and cross slopes for projects in the right of way or in an alteration were added.

Figures were added for the shoulder point, location of sidewalk relative to a guardrail, typical dimensions of a standalone pedestrian bridge. A reference to the FDOT Structures Manual was added for design of engineered steel and concrete pedestrian bridges. Drop-off hazards were defined and a figure illustrating the thresholds for when drop offs require shielding was added.

Criteria for when crosswalks should be supplemented with other treatments such as beacons, medians, curb extensions, traffic islands, or enhanced overhead lighting was added. Figures were added for raised mid-block crosswalks and crosswalks with pedestrian hybrid beacons or rectangular rapid flashing beacons. A new section on pedestrian railroad crossings was added. The references were updated.

- **Chapter 9 – Bicycle Facilities (Annette Brennan)**

Ms. Brennan presented the proposed changes for the chapter, as shown in the draft dated March 25, 2015. Criteria was added for recommended spacing of bicycle lane markings, use of bicycle lane signs, minimum widths of wide outside lanes and paved shoulders adjacent

to a barrier, and the need to evaluate, adjust, and mark drainage grates. Criteria for buffered and green bicycle lanes was added, along with a link to the FDOT APL list for green pavement marking products. A table was added with dimensions for reducing travel lane widths in resurfacing projects to provide bicycle lanes or wider outside lanes. The guidance for the placement of shared lane markings was revised and criteria for Bicycles May Use Full Lane Signs added.

The Shared Use Path section was updated to include criteria for width, shoulder area, accessibility, and the separation between the roadway and path. Information on when physical barriers or railings are needed adjacent to slopes or drop offs was added. Guidance was added to require that signs and pavement markings be consistent with the MUTCD (proper application, pattern, size and elevation) and offset from the path laterally and horizontally. A new reference section was added.

- **Chapter 15 – Traffic Calming (Steve Neff)**

Mr. Neff presented the proposed changes for the chapter, as shown in the draft dated March 23, 2015. These updates include a requirement that all signing, marking and channelization be in accordance with the MUTCD, AASHTO Policy on Geometric Design, and FHWA's Roundabout Guide. Illustrations were added for raised crosswalks, speed humps, chicanes, roundabouts, curb extensions, and crosswalks with yield condition pavement markings. Dimension descriptions for the traffic calming options were updated. The sources and reference sections were updated.

### **Subcommittee Breakout Meetings for Final Drafting of Proposed 2015 Revisions**

The Committee broke out into subcommittee groups to discuss in more detail the revisions proposed in the meeting package and to follow up on the comments from the morning's chapter presentations. The following subcommittees met:

- Chapter 6 – Roadway Lighting
- Chapter 8 – Pedestrian Facilities and Chapter 9 – Bicycle Facilities
- Chapter 11 – Work Zone Safety
- Chapter 15 – Traffic Calming.

### **Chapter Reports and Approval of Updates for 2015 Greenbook**

- **Chapter 6 – Lighting (Bernie Masing)**

Mr. Masing presented an overview of the proposed revisions to the draft following the Roadway Lighting subcommittee breakout meeting. These include:

- Revise the chapter title to “Roadway”.
- Update Section C to use the term “places of assembly” rather than “churches”.

- Add introductory language to “D Types of Illumination”.
- Update the table titles to reflect Chapter 6.
- Revise the lighting levels for mid-block crossings in Section E to 2.0 foot candles. Revise the 2<sup>nd</sup> paragraph in Section E to “When adding ...glare. Illuminance in roadway lighting is a measure of the light at the pavement surface. Luminance in roadway lighting is a measure of the reflected light from the pavement surface that is visible to the motorist’s eye. See Table 6 - 1 for ranges of illumination.” Move the remainder of the 3rd paragraph and Table 7.2 Road Surface Classifications to follow Table 7.1.
- Revise the 3rd paragraph in Section F to “It is also ...corridor. Mixing of different types of lighting may reduce the lighting uniformity. As we transition to LED, it is acceptable to have mixed lighting segments along the same corridor.”
- Revise the 2nd paragraph in Section G to read “Lighting of ...basis. Considerations include the likelihood of night time use, the role ...travel.”
- Revise Section H to read “Some locations ...provided. FHWA’s publication The Guidelines for the Implementation of Reduced Lighting on Roadways describes a process by which an agency ...existing lighting guidelines.”
- Add Section I Overhead Sign Lighting and include the following paragraph; “It is recommended that the level of illumination for overhead signs not be less than guidelines found in Table 6-3 Illuminance and Luminance for Sign Lighting. Add Table 6.3.
- Revise lettering sequence of subsequent sections.
- Revise the 2nd paragraph in new Section K to read; “Light poles ...Non-frangible light poles should be placed outside of the clear zone. They should be ...ground level. Revise the 4th paragraph to read; “The placement ...sight distance or visibility of ...control devices.”

Moved by Annette Brennan to approve the changes, seconded by Nelson Bedenbaugh. The changes were approved unanimously.

- **Chapter 8 – Pedestrian Facilities (Annette Brennan)**

Ms. Brennan presented an overview of the proposed revisions to the draft following the Pedestrian Facilities subcommittee breakout meeting. These include:

- Revise the figure in Section C illustrating the shoulder point to include the location of a sidewalk.
- Delete the third paragraph in Section D.1 beginning with “Longitudinal barriers shall be designed...” In the same section, add a figure illustrating the pipe rail detail for guardrails adjacent to a sidewalk or path.
- Revise Figure 8.4 in Section E to remove the center 5 ft. height measurement.

- Update Section G to use the term “Pedestrian Hybrid Beacon (PHB)” rather than “Hybrid Actuated Beacons (HAWKS)”. Reword the paragraph under Rail Crossings to clarify that roadways, sidewalks and shared use paths may cross rail corridors, and clarifying that the rail corridor likely pre-existed the public crossing. Add a reference for the Federal Railroad Administration and guidance that they may impose additional requirements for the design and management of public rail crossings.
- Update “bus stops” to “transit stops” in Section H.
- Update Section I References.

Moved by Andre Garganta to approve the changes, seconded by Richard Baier. The changes were approved unanimously.

- **Chapter 9 – Bicycle Facilities (Annette Brennan)**

Ms. Brennan presented an overview of the proposed revisions to the draft following the Bicycle Facilities subcommittee breakout meeting. These include:

- Add 4th detail to Figure 9-1 showing minimum width of paved shoulder to serve as a bicycle facility when adjacent to a barrier.
- Remove the bike lane dimensions from the figures.
- Revise Section C to include guidance for an 18 mph design speed with a maximum 4% grade. For speeds higher or grades steeper refer reader to AASHTO’s Guide for the Development of Bicycle Facilities.
- Revise flush shoulder illustrations to remove paved shoulder markings (\\\).

Moved by Chris Mora to approve the changes, seconded by Charles Ramdatt. The changes were approved unanimously.

- **Chapter 11 – Work Zone Safety (Chris Tavella)**

Mr. Tavella presented an overview of the proposed revisions to the draft following the Work Zone Safety subcommittee breakout meeting. These include:

- Add sentence to Section A; “Any activity within the highway right of way shall be subjected to the requirements of work zone safety.”
- Revise the first paragraph in Section E to read “The achievement ...of any roadwork. The planning objective is to develop a comprehensive temporary traffic control plan that includes the following considerations.”
- Revise the title of Section E.1.a.3 to “Planned Operations” and the revise the paragraph to read “Planned operations are scheduled roadwork projects, neither routine nor time-sensitive in nature, that are occasionally required to maintain or upgrade a street or highway.”
- Insert “temporary traffic control into the first sentence of Section E.1.b.



- Revise the first paragraph in Section E.1.c to read “The nature of ...zone safety. The development of the temporary traffic control plan should include consideration of the following factors:”
  - Revise the third bullet to read “Distribution of traffic with respect to peak traffic periods (seasonal, day of week, time of day, etc.)”
  - Revise the ninth bullet to read “Impacts of detours and diversions to business and residential community.”
  - Revise the tenth bullet to read “Pedestrian and bicycle accommodations.”
- Revise Section E.4 to read “To ensure safe and efficient roadwork operations, the temporary traffic control plan should be developed and executed in cooperation with all interested individuals and agencies including the following:”
- Change the Title for Chapter 6 to “Lighting”.

Moved by Gail Woods to approve the changes, seconded by Andy Tilton. The changes were approved unanimously.

- **Chapter 15 – Traffic Calming (Steve Neff)**

Mr. Neff presented an overview of the proposed revisions to the draft following the Traffic Calming subcommittee breakout meeting. These include:

- Add the following to the third paragraph in Section B, “Traffic calming ...tools may be considered, as well as coordinated effort with law enforcement.”
- In the “Do the following” list of Section B, revise the second bullet to read “Have an organized program including public involvement. Plans and policies should be approved and supported...residential streets.” Also added a new bullet which reads “Consider appropriate landscape treatments as part of the traffic calming design and implementation.”
- Revise the first sentence in Section C.1 to read “Unwarranted stop signs should not be used for traffic calming for the following reasons:” and revise the last sentence in the section to read “Stop signs shall be used only when warranted per the MUTCD.
- In Section C.2 retain the original height dimension for speed bumps and revise the dimension from 1 to 2 feet wide to 1 to 2 feet long.
- In Section C.3 delete the text; “dear crossing (meaning loved one)”.
- Add Speed Cushions to the types of treatments included in Table 15-1.

Moved by Gaspar Miranda to approve the changes, seconded by Keith Bryant. The changes were approved unanimously.

The meeting adjourned at 5:00 PM.

## **Friday, March 27, 2015**

### **Members in Attendance**

Bernie Masing, Ramon D. Gavarrete, Andy Tilton, Steven M. Neff, Nelson Bedenbaugh (for Kathy Thomas), Gene Howerton, David Cerlanek, John Fowler (for District 3 DDE), Rick Hall, Keith Bryant, Howard Webb, Robert Behar, Christopher R. Mora, George T. Webb, Annette Brennan, Gail Woods, Charles Ramdatt, Richard Baier, Chris Tavella, Andres Garganta, Gaspar Miranda, Richard Moss, Peter R. Brett, Margaret Smith

### **Associate Members in Attendance**

Joy Puerta, Mark V. Massaro, David F. Kuhlman, Frederick J. Schneider

### **FDOT Staff, Technical Advisors and Public in Attendance**

Duane Brautigam, Michael Shepard, Mary Anne Koos, Paul Hiers, Billy Hattaway, Chester Henson, Fred Heery, DeWayne Carver, George Borchik

The meeting reconvened at 8:00 AM. A request was made and approved to reopen discussion on Chapter 11 – Work Zone Safety for additional changes.

### **Chapter 11 – Work Zone Safety - Continued (Chris Tavella)**

- Revise Section E.1.a to read “Roadwork operations may be further classified as routine, unplanned, or planned operations.”
- In Section E.1.a.2, replace “time-sensitive” with “unplanned”

Moved by Andre Garganta to approve the changes, seconded by Robert Behar. The changes were approved unanimously.

### **Future Greenbook Revisions and Chapter Chairs**

- **Goals (Michael Shepard)**

Mr. Shepard thanked the committee for all the work that was accomplished on Thursday. He explained that we would forgo the presentation on PPM changes and bulletins and the parking lot discussion to allow for more time to discuss the Joint Administrative Procedures Committee (JAPC) revisions and plan for the 2016 meeting.

- **JAPC Revisions (Mary Anne Koos)**

The revisions to the Introduction and Chapters 3, 6, 7, 8, 9, 10, 11, 17 and 20 that have been made in response to comments from JAPC were reviewed.

- **Chapter Chairs (Mary Anne Koos)**

The list of Chapter Chairs was reviewed and finalized, with the chapter chairs as follows:

- Chapter 1 - Planning, Rick Hall
- Chapter 2 - Land Development, Margaret Smith
- Chapter 3 - Geometric Design, Howard Webb
- Chapter 4 - Roadside Design, Charles Ramdatt
- Chapter 5 - Pavement Design and Construction, Richard Moss
- Chapter 6 - Lighting, Bernie Masing
- Chapter 7 - Rail-Highway Grade Crossings, Chris Tavella
- Chapter 8 - Pedestrian Facilities, Annette Brennan
- Chapter 9 - Bicycle Facilities, Annette Brennan
- Chapter 10 - Maintenance and Resurfacing, Richard Moss
- Chapter 11 - Work Zone Safety, Chris Tavella
- Chapter 12 - Construction, Ramon Gavarrete
- Chapter 13 - Public Transit, Charles Ramdatt
- Chapter 14 - Design Exceptions, Ramon Gavarrete
- Chapter 15 - Traffic Calming, Steve Neff
- Chapter 16 - Residential Street Design, Richard Baier
- Chapter 17 - Bridges and Other Structures, Keith Bryant
- Chapter 18 - Signing and Marking, Gail Woods
- Chapter 19 - Traditional Neighborhood Development, Rick Hall
- Chapter 20 - Drainage, George Webb

- **Selection of Chapters for Future Work (Mary Anne Koos)**

The Committee identified the chapters that they would like to work on for the 2016 meeting. They agreed that Chapter 2 – Land Development, Chapter 3 – Geometric Design, Chapter 7 – Rail-Highway Grade Crossings, and Chapter 14 – Design Exceptions should be their focus for the coming year. The committee moved into breakout sessions to review the chapters and determine their future scope of work. Following the breakout session the group reconvened in the FHP Auditorium and summarized their subcommittee discussions.

## **Chapter Chair Reports for Future Greenbook Revisions and Discussion**

- **Chapter 3 – Geometric Design (Howard Webb)**

The subcommittee will review for consistency across chapters and the introduction, especially related to the definitions and terms used to describe the highway or roadway. The intent is not to change existing definitions but choose appropriate language and create definitions for new terms. They will also review outstanding issues including earlier proposed revisions for stopping and passing sight distance. The subcommittee would like to base their review on a draft of the Greenbook that includes all of the proposed changes for the 2013 edition, plus changes approved in the 2014 and 2015 meetings, and the JAPC changes. Their plans are to meet via Go-To-Meeting starting in May, with a possible face to face meeting in January 2016 to finalize the draft.

- **Chapter 14 – Design Exceptions (Ramon Gavarrete)**

Review for changes in terms such as lateral clearance, provision for adoption provided with Greenbook statute, references of 1994 publication from AASHTO, conceptual concurrence versus procedural from FDOT, and LAP projects and process. Plan is to begin with a conference call in May.

- **Chapter 2 – Land Development (Margaret Smith)**

Update the chapter to include language on the variety of land use patterns and contexts that need to be considered (compact urban/suburban/rural; greenfield/new versus infill/redevelopment), reflect contemporary markets and development patterns, and address complete streets. Recognize the differences between greenfield versus infilling, greenfield-grey field-brown field; Traditional Neighborhood Design (TND) and Transit Oriented Development (TOD). Look at the role of speed as a control within the various contexts (context-based speed. Also consider available parking for users, traffic control, selecting the operating speed concepts for the community, adequate access for fire & rescue emergencies, proper placement of utilities, adequate drainage facilities, landscaping & street trees, levels of service for transportation balance – autos, walkable, bikes, fire codes (20' clear), and where appropriate shared lane conditions for cyclists.

They identified the need to harmonize with Chapter 1 and other chapters in the Greenbook and that the Committee should consider also working on Chapter 1. They would like to begin work in June.

- **Chapter 1 – Planning (Rick Hall)**

The committee discussed whether Chapter 1 – Planning should be eliminated from the Greenbook or merge with Chapter 2. It was decided to retain Chapter 1 as a separate chapter and it was added to the list of chapters to work on for the 2016 meeting.

- **Chapter 7 – Rail-Highway Grade Crossings (Chris Tavella)**

The subcommittee agreed the chapter needs to be updated, and should address high speed rail, signal preemption, quiet zones, pedestrian and bicyclist crossings, school bus routes, compliance with MUTCD, possibility of a sealed corridor, and expand to address high speed rail. Update the references. Update the diagrams to include high speed rail, the tables in the chapter currently have a maximum speed of 90 mph. Review station design, rail crossing safety inspections, communication, inspection and maintenance of crossings, parallel routes, special signage and storage for certain types of trucks. Look at the Rail Handbook as resource. A teleconference will be held in early summer.

## **2016 Greenbook Meeting**

Members asked that we hold the meeting in February, in a location where we can experience good urban design and have more affordable hotel rates. They prefer to concentrate on Greenbook business rather than having extra presentations. For the 2016 meeting, members would like to receive a copy of the current adopted Florida Greenbook, with proposed changes in redline format.

The Committee would like to work this summer on a 2015 draft for rulemaking to harmonize Chapter 3 with Chapters 8 and 9, and any other chapters that would benefit from consistent highway terminology. The 2015 addition should also include the approved changes from the 2014 and 2015 meetings. Their goal is to submit for rulemaking at the end of the summer, and create a 2015 edition. The work of the other chapters would be submitted in future rulemaking efforts, possibly with a new edition every two years.

Members felt more work was needed to promote the Greenbook, especially with cities, developers and consulting engineers. As examples, they suggested FDOT develop short articles for engineering newsletters and announce updates via our contact mailer.

The committee asked that staff clarify the standing of the Greenbook as it applies to city streets, or where the public is invited to travel and review *Florida Statutes* as they apply to the Greenbook.

The Meeting adjourned at 11:45 AM.

# *Florida Greenbook Advisory Committee Meeting*

## *Meeting Review Package*

*March 26-27, 2015*



## FLORIDA GREENBOOK ADVISORY COMMITTEE MEMBERS

### DISTRICT 1

Bernie Masing, P.E.  
District Design Engineer  
FDOT - District 1  
801 North Broadway Street  
Bartow, Florida 33830-1249  
(863) 519-2543, FAX (863) 519-2892  
[bernie.masing@dot.state.fl.us](mailto:bernie.masing@dot.state.fl.us)

Ramon D. Gavarrete, P.E.  
County Engineer/Utilities Director  
Highlands County  
Board of County Commissioners  
505 South Commerce Avenue  
Sebring, Florida 33870-3869  
(863) 402-6877, FAX (863) 402-6548  
[rgavarre@hcbcc.org](mailto:rgavarre@hcbcc.org)

Andy Tilton, P.E.  
Water Resource Director  
Johnson Engineering, Inc.  
251 West Hickpochee Avenue  
LaBelle, Florida 33935  
(863) 612-0594, Fax (863) 612-0341  
[atilton@johnsoneng.com](mailto:atilton@johnsoneng.com)

Steven M. Neff, P.E.  
Public Works Director  
City of Cape Coral  
Public Works  
P.O. Box 150027  
Cape Coral, Florida 33915-0027  
(239) 574-0702, FAX (239) 573-3087  
[sneff@capecoral.net](mailto:sneff@capecoral.net)

### DISTRICT 2

Kathyrn D. Thomas, P.E.  
District Design Engineer  
FDOT - District 2  
1901 South Marion Street  
Lake City, Florida 32025-5814  
(386) 961-7583, FAX (386) 961-7809  
[kathy.thomas@dot.state.fl.us](mailto:kathy.thomas@dot.state.fl.us)

Kenneth Dudley, P.E.  
County Engineer  
Taylor County  
Board of County Commissioners  
201 East Green Street  
Perry, Florida 32347  
(850)838-3500x104, FAX (850)838-3501  
[county.engineer@taylorcountygov.com](mailto:county.engineer@taylorcountygov.com)

Gene Howerton, P.E.  
Vice President  
Arcadis U.S., Inc.  
1650 Prudential Drive, Suite 400  
Jacksonville, Florida 32207  
(904) 721-2991, FAX (904) 861-2840  
[Gene.Howerton@arcadis-us.com](mailto:Gene.Howerton@arcadis-us.com)

David Cerlanek, P.E., P.T.O.E., C.P.M.  
Asst. Public Works Director / Co. Engineer  
Alachua County Public Works Department  
P.O. Box 1188  
Gainesville, FL 32602  
(352) 374-5245 x214, FAX (352) 337-6243  
[dcerlanek@alachuacounty.us](mailto:dcerlanek@alachuacounty.us)

### **DISTRICT 3**

Scott Golden, P.E.  
District Design Engineer  
FDOT - District 3  
Post Office Box 607  
Chipley, Florida 32428  
(850) 330-1492, FAX (850) 330-1148  
[scott.golden@dot.state.fl.us](mailto:scott.golden@dot.state.fl.us)

Rick Hall, P.E.  
Hall Planning and Engineering, Inc.  
322 Beard Street  
Tallahassee, Florida 32303  
(850) 222-2277, FAX (850) 222-6555  
[rickhall@hpe-inc.com](mailto:rickhall@hpe-inc.com)

Roger A. Blaylock, P.E.  
County Engineer  
Santa Rosa County  
6051 Old Bagdad Highway, Suite 300  
Milton, Florida 32583  
(850) 981-7100, FAX (850) 983-2161  
[RogerB@santarosa.fl.gov](mailto:RogerB@santarosa.fl.gov)

Keith Bryant, P.E., P.T.O.E.  
Traffic Engineering Manager  
Bay County  
840 West 11th Street  
Panama City, Florida 32401  
(850) 248-8740, FAX (850) 248-8749,  
[kbryant@baycountyfl.gov](mailto:kbryant@baycountyfl.gov)

### **DISTRICT 4**

Howard Webb, P.E.  
District Design Engineer  
FDOT - District 4  
3400 West Commercial Blvd  
Ft. Lauderdale, Florida 33309  
(954) 777-4439, FAX (954) 777-4482  
[howard.webb@dot.state.fl.us](mailto:howard.webb@dot.state.fl.us)

Robert Behar, P.E.  
President  
R.J. Behar and Company, Inc.  
6861 SW 196 Avenue, Suite 302  
Pembroke Pines, Florida 33332  
(954) 680-7771  
[bbehar@rjbehar.com](mailto:bbehar@rjbehar.com)

Christopher R. Mora, P.E.  
Public Works Director  
Indian River County  
1801 27th Street  
Vero Beach, Florida 32960  
(772) 226-1379, FAX (772) 778-9391  
[cmora@ircgov.com](mailto:cmora@ircgov.com)

George T. Webb, P.E.  
County Engineer  
Palm Beach County  
Post Office Box 21229  
West Palm Beach, Florida 33416-1229  
(561) 355-2006, FAX (561) 656-7290  
[GWebb@pbcgov.org](mailto:GWebb@pbcgov.org)



## DISTRICT 5

Annette Brennan, P.E.  
District Design Engineer  
FDOT - District 5  
719 South Woodland Boulevard  
Deland, Florida 32720  
(386) 943-5543, FAX (386) 736-5302  
[annette.brennan@dot.state.fl.us](mailto:annette.brennan@dot.state.fl.us)

Gail Woods, P.E.  
Transportation Manager  
WBQ Design and Engineering, Inc.  
201 N. Magnolia Avenue, Suite 200  
Orlando, Florida 32801  
(407) 839-4300, FAX (407) 839-1839  
[Gwoods@wbq.com](mailto:Gwoods@wbq.com)

Charles Ramdatt, P.E., P.T.O.E.  
Transportation Engineering Div. Manager  
City of Orlando  
400 South Orange Avenue  
P.O. Box 4990  
Orlando, Florida 32802  
(407) 246-3186, FAX (407) 246-3392  
[Charles.Ramdatt@cityoforlando.net](mailto:Charles.Ramdatt@cityoforlando.net)

Richard Baier, P.E.  
Sumter County Public Works Director  
319 East Anderson Avenue  
Bushnell, Florida 33513  
(352) 569-6700, FAX (352) 569-6701  
[richard.baier@sumtercountyfl.gov](mailto:richard.baier@sumtercountyfl.gov)

## DISTRICT 6

Chris Tavella, P.E.  
District Design Engineer  
FDOT - District 6  
1000 NW 111th Avenue  
Miami, Florida 33172  
(305) 470-5103, FAX (305) 470 5338  
[chris.tavella@dot.state.fl.us](mailto:chris.tavella@dot.state.fl.us)

Andres Garganta, P.E.  
Vice President  
CSA Group, Inc.  
6100 Blue Lagoon Drive, Suite 300  
Miami, Florida 33126  
(305) 461-5484x7304, FAX (305) 461-5494  
[agarganta@csagroup.com](mailto:agarganta@csagroup.com)

Gaspar Miranda, P.E.  
Assistant Director, Highway Engineering  
Miami-Dade County  
Public Works Department  
111 N.W. 1st Street, Suite 1510  
Miami, Florida 33128  
(305) 375-2130, FAX (305) 679-7738  
[GXM@miamidade.gov](mailto:GXM@miamidade.gov)

Juvenal Santana, P.E.  
Assistant Director  
City of Miami Public Works Department  
444 S.W. 2nd Avenue, 8th Floor  
Miami, Florida 33130  
(305) 416-1218, FAX (305) 416-1278  
[jsantana@miamigov.com](mailto:jsantana@miamigov.com)

## DISTRICT 7

Richard Moss, P.E.  
District Design Engineer  
FDOT - District 7  
11201 N. McKinley Drive  
Tampa, Florida 33612  
(813) 975-6030, FAX (813) 975-6150  
[richard.moss@dot.state.fl.us](mailto:richard.moss@dot.state.fl.us)

Richard Diaz, Jr., P.E.  
President  
Diaz Pearson & Associates, Inc.  
4202 El Prado Blvd.  
Tampa, Florida 33629  
(813) 258-0444, FAX (813) 258-4440  
[richard@diazpearson.com](mailto:richard@diazpearson.com)

Peter R. Brett, P.E.  
Chief Engineer Transportation Division  
City of Tampa  
306 E. Jackson Street, 4E  
Tampa, Florida 33602  
(813) 274-8054  
[pete.brett@tampagov.net](mailto:pete.brett@tampagov.net)

Margaret W. Smith, P.E.  
Engineering Services Director/  
County Engineer  
West Pasco Government Center  
87313 Citizens Drive, Suite 321  
New Port Richey, FL 34654  
(727) 847-2411, ext 7452  
[mwsmith@pascocountyfl.net](mailto:mwsmith@pascocountyfl.net)

## ASSOCIATE MEMBERS

Michael Shepard, P.E., Chairperson  
State Roadway Design Engineer  
FDOT - Central Office  
605 Suwannee St., MS 32  
Tallahassee, Florida 32399-0450  
(850) 414-4283, FAX (850) 414-5261  
[michael.shepard@dot.state.fl.us](mailto:michael.shepard@dot.state.fl.us)

Mary Anne Koos  
Special Projects Coordinator  
FDOT - Central Office  
605 Suwannee St., MS 32  
Tallahassee, Florida 32399-0450  
(850) 414-4321, FAX (850) 414-5261  
[maryanne.koos@dot.state.fl.us](mailto:maryanne.koos@dot.state.fl.us)

Vacant  
Roadway Design Engineer  
FDOT - Central Office  
605 Suwannee St., MS 32  
Tallahassee, Florida 32399-0450  
(850) 414-4283, FAX (850) 414-5261

Paul Hiers, P.E.  
Roadway Design Criteria Administrator  
FDOT - Central Office  
605 Suwannee St., MS 32  
Tallahassee, Florida 32399-0450  
(850) 414-4324, FAX (850) 414-5261  
[paul.hiers@dot.state.fl.us](mailto:paul.hiers@dot.state.fl.us)

Joy Puerta  
City Transportation Analyst  
City of Boca Raton,  
Municipal Services Dept.  
201 West Palmetto Park Road  
Boca Raton, Florida 33432  
(561) 416-3410, FAX (561) 416-3418  
[jpuerta@ci.boca-raton.fl.us](mailto:jpuerta@ci.boca-raton.fl.us)

## ASSOCIATE MEMBERS (Continued)

Mark V. Massaro, P.E.  
Director, Public Works Dept.  
Orange County  
4200 South John Young Parkway  
Orlando, Florida 32839  
(407) 836-7970, FAX (407) 836-7716  
[mark.massaro@ocfl.net](mailto:mark.massaro@ocfl.net)

David F. Kuhlman  
Florida Power & Light Company  
7200 NW 4<sup>th</sup> Street  
Plantation, Florida 33317  
(954) 321-2188  
[David.F.Kuhlman@fpl.com](mailto:David.F.Kuhlman@fpl.com)

Frederick J. Schneider, P.E.  
FACERS Representative  
Lake County Public Works  
437 Ardice Avenue  
Eustis, Florida 33726  
(352) 483-9040, FAX (352) 483-9015  
[fschneider@lakecountyfl.gov](mailto:fschneider@lakecountyfl.gov)

Allen W. Schrupf, P.E.  
Senior Associate  
DRMP, Inc.  
941 Lake Baldwin Lane  
Orlando, Florida 32814  
(407) 897-0594, FAX (407) 896-4836  
[aschrumpf@drmp.com](mailto:aschrumpf@drmp.com)

Gabrielle (Gabe) Matthews  
State Transit Planner  
FDOT – Central Office  
605 Suwannee Street, MS 26  
Tallahassee, Florida 32399-0450  
(850) 414-4532  
[gabrielle.matthews@dot.state.fl.us](mailto:gabrielle.matthews@dot.state.fl.us)

Duane Brautigam, P.E.  
Director, Office of Design  
FDOT - Central Office  
605 Suwannee St., MS 38  
Tallahassee, FL 32399-0450  
(850) 414-4175, FAX (850) 414-4791  
[duane.brautigam@dot.state.fl.us](mailto:duane.brautigam@dot.state.fl.us)

Chester Henson, P.E.  
State Traffic Standards Engineer  
FDOT - Central Office  
605 Suwannee St., MS 32  
Tallahassee, Florida 32399-0450  
(850) 414-4117, FAX (850) 414-5261  
[chester.henson@dot.state.fl.us](mailto:chester.henson@dot.state.fl.us)

Billy Hattaway, P.E.  
District Secretary  
FDOT - District 1  
801 North Broadway Street  
Bartow, Florida 33830-1249  
(863) 519-2201, FAX (863) 519-2892  
[billy.hattaway@dot.state.fl.us](mailto:billy.hattaway@dot.state.fl.us)

Robert Robertson, P.E.  
State Structures Design Engineer  
FDOT - Central Office  
605 Suwannee St., MS 33  
Tallahassee, Florida 32399-0450  
(850) 414-4267, FAX (850) 414-4955  
[robert.robertson2@dot.state.fl.us](mailto:robert.robertson2@dot.state.fl.us)

Andre Pavlov, P.E.  
Assistant State Structures Design  
Engineer  
FDOT - Central Office  
605 Suwannee St., MS 33  
Tallahassee, Florida 32399-0450  
(850) 414-4293, FAX (850) 414-4955  
[andre.pavlov@dot.state.fl.us](mailto:andre.pavlov@dot.state.fl.us)

**ASSOCIATE MEMBERS (Continued)**

Fred Heery  
Deputy State Traffic Operations Engineer  
FDOT - Central Office  
State Traffic Engineering and  
Operations Office  
605 Suwannee St., MS 36  
Tallahassee, Florida 32399-0450  
(850) 410-5416, FAX (850) 410-5503  
[fred.heery@dot.state.fl.us](mailto:fred.heery@dot.state.fl.us)

Lora Hollingsworth, P.E.  
Chief Safety Officer  
FDOT - Central Office  
605 Suwannee St., MS 53  
Tallahassee, Florida 32399-0450  
(850) 245-1504, FAX (850) 245-1554  
[lora.hollingsworth@dot.state.fl.us](mailto:lora.hollingsworth@dot.state.fl.us)

Joseph Santos, P.E.  
Transportation Safety Engineer  
FDOT - Central Office  
605 Suwannee Street, MS 53  
Tallahassee, Florida 32399-0450  
(850) 245-1502, FAX (850) 245-1554  
[joseph.santos@dot.state.fl.us](mailto:joseph.santos@dot.state.fl.us)

## **Minutes (Draft)**

### **2014 FLORIDA GREENBOOK ADVISORY COMMITTEE MEETING**

**Thursday, March 27, 2014, 8:00 AM – 5:00 PM**

**Friday, March 28, 2014, 8:00 AM – 12:00 PM**

FDOT's Turnpike Headquarters, Auditorium A  
Turkey Lake Service Plaza  
Ocoee, Florida 34761

---

#### **Thursday, March 27, 2014**

##### **Members in Attendance**

Bernie Masing, Ramon D. Gavarrete, Andy Tilton, Steven M. Neff, Jimmy Pitman, Kenneth Dudley, David Cerlanek, Rick Hall, Keith Bryant, Howard Webb, Robert Behar, Christopher R. Mora, George T. Webb, Annette Brennan, Gail Woods, Charles Ramdatt, Scott Cottrell, Chris Tavella, Andres Garganta, Juvenal Santana, Ron Chin, Peter R. Brett

##### **Other FDOT Staff and Public in Attendance**

Duane Brautigam, Michael Shepard, Mary Anne Koos, Frank Sullivan, Billy Hattaway, Joy Puerta, Mark V. Massaro, David F. Kuhlman, Frederick J. Schneider, Andre Pavlov, Chester Henson, Fred Heery, Gabrielle (Gabe) Matthews, Miranda Glass, Gevin McDaniel, Alan Hart, Chad Swails

##### **General Information**

- Welcome and Introductions (Michael Shepard)  
Florida Greenbook Committee and Associate Member Changes - Changes in membership for the Greenbook Committee were reviewed and new members, Peter Brett (City of Tampa) and Juvenal Santana (City of Miami) were introduced. Ben Money (City of Tampa) and Elyrosa Estevez (City of Miami) were thanked for their service on the Greenbook Committee.
- Review March 2013 Meeting Minutes & Vote to Approve (Mary Anne Koos)  
The minutes were approved by the Committee with no edits.
- Review Contact Information (Mary Anne Koos)  
A sheet was circulated for everyone to update their contact information.
- Update Subcommittee Assignments (Mary Anne Koos)  
A listing of current subcommittee assignments was circulated. Members updated their committee membership preferences. Subcommittees that are in need of additional members are the Maintenance of Traffic, Bridges, and Local Specifications.

##### **Rulemaking and Sunshine Law**

- Rulemaking Process (Susan Schwartz, General Counsel's Office)  
The Rule for the Florida Greenbook is [14-15.002, Florida Administrative Code \(F.A.C.\)](#),
- "Rulemaking" is defined as the adoption, amendment or repeal of a rule and is the process used to adopt the Greenbook. In its simplest form, rulemaking consists of drafting the rule

text, providing notice to the public, accepting public comment and filing the rule for adoption. Revisions to the Florida Greenbook begin with drafting proposed changes and review by the Committee. The proposed changes are then reviewed by FDOT's General Counsel Office and approved by FDOT's Secretary.

- A review by the Office of Financial and Regulatory Responsibility (OFAR), located in the Governor's Office is also required to evaluate the regulatory costs to business. Since the Greenbook applies to public agencies, there is considered to be no impact. The 2013 Greenbook is in rule development and has been published in the Florida Administrative Register. An opportunity for public comment has been provided, however no public workshop was requested and no comments have been received.
- The Greenbook is published first in Rule Development, then in Rule Making. If there are no comments, or if all comments are addressed, it then goes to the Department of State (DOS) for Rule Adoption. Twenty days after it is posted by DOS, the manual becomes effective.
- Sunshine Law (Susan Schwartz, General Counsel's Office)

To comply with Florida's Sunshine law, Susan explained that members cannot discuss with each other the action they intend to take at a later meeting of the Greenbook Committee. Subcommittee meetings don't need to be noticed if the meeting is just for fact finding and the final recommendations come before the full committee for approval.

### **Presentations**

- **MUTCD Typical Applications Not Contained Within the FDOT Series 600 Indexes** (David Kuhlman)

This presentation included an overview of requirements for Maintenance of Traffic (MOT) provided in the MUTCD, the 2010 Utility Accommodation Manual and the Design Standards 600 Series. Modifications of the Index 600 Series, developed by the Florida Power and Light Company, were also presented. These modifications were developed to minimize the requirements for short duration Maintenance of Traffic on low volume, low speed roadways. The request was to include the revised standards in the Florida Greenbook.

- The Committee decided to refer the issue to the Chapter 11 - Work Zone Safety Subcommittee for further investigation and recommendation. The Committee cited the current option of following the MUTCD as the minimum standard, or preparing a local Standard/Design signed and sealed by a Florida registered engineer. The Subcommittee will address the request during the Chapter 11 workshop.

### **Presentation of Proposed Revisions for 2015 Greenbook**

- **Introduction and Definition of Terms** (Mary Anne Koos)

Ms. Koos presented the proposed changes for the Introduction and Definition of Terms. These updates include adding definitions for Boarding and Alighting Areas, Para Transit, Urban Area and Urbanized Areas.

- **Chapter 1 – Planning** (Mary Anne Koos)

Ms. Koos presented the chapter edits. The edits included enhancing the language addressing multi-modal transportation systems, reorganization of the language addressing function and safety of the roadway, and updates to the Reference’s Section, including a reference to the *2010 Highway Capacity Manual*.

- **Chapter 3 – Geometric Design** (Howard Webb)

Mr. Webb and Mr. Sullivan presented the changes proposed for Chapter 3 regarding passing sight distance. FDOT’s Traffic Engineering and Operations Office has recently adopted the values for passing sight distance found in the MUTCD in their MUTS Manual. The current criterion in the Florida Greenbook is based upon language in the PPM, and not consistent with the guidance found in the MUTCD and MUTS. The subcommittee proposes to delete the passing sight distance criteria in the Florida Greenbook and refer to the MUTCD.

- **Chapter 4 – Roadside Design** (Charles Ramdatt) - Mr. Ramdatt and Mr. Sullivan presented an overview of the proposed changes for the Roadside Design chapter. These include revised guidance on addressing roadside hazards, vertical curves, roadside canals, culverts, poles and support structures, and bus shelters. A reference to AASHTO’s Roadside Design Guide was added.

- **Chapter 13 – Public Transit** (Charles Ramdatt) - Mr. Ramdatt explained the goal for the proposed revision was to provide new or updated information on bus bays, shelters, and boarding and alighting areas. New and updated references were also provided.

- **Chapter 16 – Residential Street Design** (Scott Cottrell) - Mr. Cottrell explained the goal for the proposed revision was to improve the connectivity of the local street system, address intersection sight distance and design speed, and improve the guidance provided for pedestrians and cyclists. New and updated references were also provided.

- **Chapter 17 – Bridges** (Jimmy Pittman) – Mr. Pittman gave an overview of the updated chapter. The general goals were to provide additional information on the design of retaining walls and sound barriers and update the LRFD reference to include the applicable Interims.

- **Chapter 18 – Signing and Marking** (Gail Woods) – Ms. Woods gave an overview of the changes proposed. The general goals were to update the guidance for the design and placement of street name signs and provide information on community wayfinding, dynamic message signs, and audible vibratory pavement markings.

## **Presentation**

- **Bike-Pedestrian Safety Initiative and Complete Streets** (Billy Hattaway) - Secretary Hattaway gave an overview of the Secretary’s Initiative to improve traffic safety in Florida. FDOT is offering training in Designing for Pedestrian Safety, Road Safety Audit Training, Roundabout Design, and developing a Pedestrian Safety Action Plan. FDOT is also developing targeted engineering solutions, and focused media campaigns and law enforcement and education training. Policy initiatives include complete streets policy and implementation, promotion of modern roundabouts, guidance for road diets on the state system, context based bicycle and pedestrian facilities, US Bike Routes US 90 and US 1, and update of traffic laws.

## **Subcommittee Meetings for Final Drafting of Proposed 2015 Revisions**

- The Committee broke out into subcommittee groups to discuss in more detail the revisions proposed in the meeting package and to follow up on the comments from the morning's chapter presentations. The following subcommittees met: Introduction and Definition of Terms, Chapter 3 – Geometric Design, Chapter 4 – Roadside Design, Chapter 13 – Public Transit, Chapter 16 – Residential Street Design, Chapter 17 – Bridges and Other Structures, and Chapter 18 – Signing and Marking.

## **Chapter Reports and Approval of Updates for 2015 Greenbook**

### **Proposed Updates for 2015 Greenbook**

- **Introduction and Definition of Terms** (Mary Anne Koos) – Ms. Koos presented an overview of the proposed changes for the Introduction and Definition of Terms. These updates include:
  - Revise the definition for Bus Stop Pad to Boarding and Alighting Area as shown in the meeting package.
  - Retain the current language defining public transit and add the definition for Para Transit included in the meeting package.
  - Add definitions for urban area and urbanized area included in the meeting package, which were based upon FHWA's language and consistent with the Plans Preparation Manual (PPM) definitions.

Moved by Andy Tilton to approve the changes, seconded by Steve Neff. The changes were approved unanimously.

- **Chapter 1 – Planning** (Mary Anne Koos) – Ms. Koos gave an overview of the development of the updated chapter. The general goals were to recognize a more multi-modal transportation system, address function and safety of the roadway earlier in the organization of the chapter, update the References section, including a reference to the *2010 Highway Capacity Manual*. The proposed updates are those presented in the meeting package with the following edits:
  - Use “street” rather than “transportation” to describe the “system” in the fourth paragraph.
  - Revise Section B.1.c to read “Unless prohibited by law, a variety of travelers should be expected on all public roads. These could include pedestrians, bicyclists, and motor vehicle operators and passengers. Types and relative volumes of people expected to use the street or highway influence trip characteristics and design features.”

Moved by Andy Tilton to approve the changes, seconded by Robert Behar. The changes were approved unanimously.

- **Chapter 3 – Geometric Design** (Howard Webb) – Mr. Webb and Mr. Sullivan explained the goal for the proposed revision was to harmonize the Florida Greenbook with the 2011 AASHTO Greenbook related to stopping and passing sight distance.
  - Revise the object height for stopping sight distance to 2.0 from 0.5 feet in Section C.3.a - Stopping Sight Distance.
  - Revise Section C.3.b - Passing Sight Distance to be consistent with the language presented in the meeting materials.



- Update Table 3-3 - Sight Distances and Lengths of Vertical Curves with the corrected values for stopping sight distance using the 2.0 foot object height. Rounded K Values for Minimum Lengths of Vertical Curves will be updated to be consistent with AASHTO. Remove the section from the Table entitled Minimum Passing Sight Distances (Feet).

Moved by Charles Ramdatt to approve the changes, seconded by Keith Bryant. The changes were approved unanimously.

- **Chapter 4 – Roadside Design** (Charles Ramdatt) – Mr. Ramdatt and Mr. Sullivan presented an overview of the proposed changes for the Roadside Design chapter. The proposed updates are those presented in the meeting package with the following edits:
  - Revise Section C - Objectives as shown in the meeting materials except for the 4<sup>th</sup> bullet which was revised to read “Roadsides that accommodate necessary maintenance vehicles, emergency maneuvers and emergency parking.”
  - Revise Section D - Roadside Design as shown in the meeting materials. Add a sentence to the end of the section which reads “The AASHTO Roadside Safety Analysis Program (RSAP) is the recommended tool for evaluating the cost effectiveness of shielding roadside hazards.”
  - Revise Section D.1.a - Horizontal Curves as shown in the meeting package except delete the reference to “Chapter 18, Signing and Marking.”
  - Revise Section D.1.b - Vertical Curves as shown in the meeting package except revise the last sentence to read “Vertical curves with inadequate stopping sight distance may be mitigated with appropriate advanced signage and other warning devices, or can be reconstructed.”
  - Section D.4 – Roadside Canals was deferred to a separate presentation on the next day.
  - Revise Section D.13 - Bus Shelters to read as follows “Bus shelters should be moved back as far as practical from the roadside with pedestrian access to the bus stop boarding and alighting area at the roadside.”
  - Revise Section E - Protective Devices as shown in the meeting package except replace the term “guardrail and crash cushions” with “longitudinal barriers”.
  - Revise the second paragraph in Section E.1.c - Location to read “Barriers shall be offset from obstacles or other hazards a sufficient distance so the barrier may deflect without interference. The location of the barrier should be selected in close coordination with the design of its deflection characteristics.”

Moved by Andy Tilton to approve the changes, seconded by Howard Webb. The changes were approved unanimously.

- **Chapter 13 – Public Transit** (Charles Ramdatt) - Mr. Ramdatt explained the goal for the proposed revision was to provide new or updated information on bus bays, shelters, and boarding and alighting areas. New and updated references were also provided. The changes proposed in the meeting package were approved, except for the following:
  - Revise the second paragraph in Section C.1 - Boarding and Alighting (B&A) Areas to read “The slope of the B&A area parallel to the roadway shall to the extent practicable, be the same as the roadway. For water drainage, a maximum slope of 1:50 (2%) perpendicular to the roadway is allowed. Benches and other site amenities shall not be placed on the B&A area. The B&A area can be located either within or outside the shelter, and shall be connected to streets, sidewalks, or pedestrian circulation paths by an accessible route.”
  - Revise the draft figures 13-1 and 13-2 to show two cross sections for each figure. Cross section AA through the boarding and alighting area and cross section BB through the connection to the roadway.
  - Revise last sentence in Section D.3 - Bus Stop Lighting to read “The use of solar panel lighting for bus bays is another option that should be considered.” Direction was also given to work to harmonize this section with Chapter 6 and 8 of the Greenbook in future revisions.
  - In addition to the updated references in Section E - References for Informational Purposes, a suggestion was made to add a reference and link to Chapter 14-20, Florida Administrative Code.

Moved by David Cerlanek to approve the changes, seconded by Gail Woods. The changes were approved unanimously.

- **Chapter 16 – Residential Street Design** (Scott Cottrell) - Mr. Cottrell explained the goal for the proposed revision was to improve the connectivity of the local street system, address intersection sight distance and design speed, and improve the guidance provided for pedestrians and cyclists. New and updated references were also provided. The changes proposed in the meeting package were approved, except for the following:
  - Revise the first sentence in Section C.5.a - Width of Roadway to read “The minimum width of a two-way residential roadway should be 20 feet from edge-of-pavement to edge-of-pavement (excluding curbs and gutters).”
  - Revise Section C.5.b - Medians to read “When used in residential areas, medians or traffic separators should conform to Chapter 3 or Chapter 19.”
  - Revise Section C.8.a - Bicycle Facilities to add the sentence “For bike lane transitions, see Chapter 9” to the end of the paragraph.
  - Revise the last sentence in Section C.9.b - Shared Use Paths to read “Shared use paths may be used by golf carts in certain areas, under certain circumstances in accordance with Sections 316.212, 316.2125 and 316.2126, F.S.

Moved by Andy Tilton to approve the changes, seconded by Annette Brennan. The changes were approved unanimously.

- **Chapter 17 – Bridges and Other Structures** (Jimmy Pittman) – Mr. Pittman gave an overview of the updated chapter. The general goals were to provide additional information

on the design of retaining walls and sound barriers and update the LRFD reference to include the applicable Interims. The changes proposed in the meeting package were approved, except for the following:

- Revise Section C.1 - Bridges to read “At a minimum, the AASHTO Load and Resistance Factor Design (LRFD) Bridge Design Specifications, 6<sup>th</sup> Edition (2012) with applicable Interims shall be used. Any bridge reconstruction (i.e., lengthening, widening, and/or major component replacement) shall be designed as specified in this section. Record of such reconstruction shall be maintained as specified in Section D of this chapter. The remaining design life should be considered in the design.
- A direct link to the Structures Design Guidelines was added to Section H, References for Informational Purposes

Moved by Howard Webb to approve the changes, seconded by Ron Chin. The changes were approved unanimously.

- **Chapter 18 – Signing and Marking** (Gail Woods) – Ms. Woods gave an overview of the changes proposed. The general goals were to update the guidance for the design and placement of street name signs and provide information on community wayfinding, dynamic message signs, and audible vibratory pavement markings. The language adopted was based upon the materials presented in the meeting package, except for the following:
  - Retain the Chapter title “Signing and Marking “until the chapter is updated to include traffic signals.
  - Revise the last sentence of the first paragraph in Section C.2 - Advance Traffic Control Signs to read “The visibility criteria for traffic signals shall be based on having a continuous view of at least two signal faces for the distance specified in **Table 4D-2. Minimum Sight Distance for Signal Visibility of the MUTCD.**”
  - Revise the guidance for when two sign panels are used in Section C.3.a Standards to read “when two sign panels are used, install one sign panel on the left and the other sign panel on the right side of the signal heads; or”
  - Revise Section C.4 - Community Wayfinding Guidance to read “Community wayfinding guide signs should be developed and approved through local resolution with criteria for the destinations shown on the community wayfinding guide sign system plan. Any wayfinding guide sign should be used in accordance with Rule 14-51.030, F.A.C. The intent is to provide guidance and navigation information to local cultural, historical, recreational, and tourist activities. No destination should be displayed for the purpose of advertising.”
  - Revise Section D.1- 6-inch Pavement Markings to read “6-inch pavement markings should be used for all pavement center line, lane separation line and edge line markings”.
  - Revise Section D.2 - Reflective Pavement Markers to read "To provide greater emphasis and increase visibility, reflective (raised) pavement markers (RPM) may be placed at 40-foot spacing along the centerline markings of roadways.”
  - Revise the title of Section D.3 to read “Audible Vibratory Pavement Markings.” The proposed language was revised to read “For high speed roadways, audible, vibratory markings should be considered.”

Moved by Andy Tilton to approve the changes, seconded by Robert Behar. The changes were approved unanimously.

### **Adjourn**

- The meeting adjourned for the day at 5:00 PM.

## **Friday, March 28, 2014**

### **Members in Attendance**

Bernie Masing, Ramon D. Gavarrete, Andy Tilton, Steven M. Neff, Jimmy Pitman, Kenneth Dudley, David Cerlanek, Keith Bryant, Howard Webb, Robert Behar, George T. Webb, Annette Brennan, Gail Woods, Charles Ramdatt, Scott Cottrell, Chris Tavella, Andres Garganta, Ron Chin, Peter R. Brett

### **Other FDOT Staff and Public in Attendance**

Duane Brautigam, Michael Shepard, Mary Anne Koos, Frank Sullivan, Miranda Glass, Billy Hattaway, Joy Puerta, Mark V. Massaro, David F. Kuhlman, Frederick J. Schneider, Andre Pavlov, Chester Henson, Fred Heery, Gabrielle (Gabe) Matthews, Gevin McDaniel, Alan Hart, Chad Swails

### **Future Greenbook Revisions**

- **Goals** (Michael Shepard) – Mr. Shepard thanked the committee for all the work that was accomplished on Thursday and explained that following a presentation on AASHTO Greenbook criteria, the committee would be asked to identify the chapters that need revisions. Also, later this morning there would be further discussion on the guidance on Chapter 4 and roadside canals. Breakout sessions for those selected chapters would then follow. Similar to the process that was used to develop the new Drainage Chapter, technical experts from FDOT’s Central or District Offices will be assigned to each chapter. Technical experts from local governments and consultants are also welcome to serve on Chapter Subcommittees.
- **Review of 2011 AASHTO “Greenbook” Criteria** (Frank Sullivan) – The presentation included an overview of the general changes between the 2011 and 2004 Greenbooks. The major differences are:
  - Emphasis on designer consideration of the “context” of the project area and multi-modal design
  - New design vehicles were added including the SU-40 and tandem axle trucks, and the WB-50 was replaced with WB-62
  - Clarifies that the roadway width includes the shoulder to be consistent with the Roadside Design Guide
  - Passing sight distance for two lane rural highways was revised based upon NCHRP Report 605 and is now consistent with the MUTCD
  - Superelevation values were updated
  - Added information on Rumble Strips

- Added vertical clearance criteria for pedestrian overpasses and structures on collectors
- Allows the use of 10' lanes on urban arterials with low bus and truck traffic and design speeds < than 35 mph
- Updated the pedestrian crossing criteria at intersections to be consistent with the Highway Capacity Manual
- Added information on double and triple lefts based upon NCHRP 505
- Updated exhibits for grade separations and interchanges, including roundabout ramp terminals, ramp metering, and left side ramp terminals

FHWA has not adopted the 2011 Greenbook; however, they do allow states to adopt the portions they felt were appropriate. The 2004 AASHTO Greenbook is referenced in the PPM. It was decided the 2004 AASHTO Greenbook will be the used as the basis for the 2013 Florida Greenbook.

- **Selection of Chapters for Future Work** (Michael Shepard) - The Committee agreed to work on Chapter 6 – Roadway Lighting, Chapter 8 – Pedestrian Facilities, Chapter 9 – Bicycle Facilities, Chapter 11 – Work Zone Safety and Chapter 15 – Traffic Calming in the subcommittee workshops. There was agreement to not address traffic signals at this time in Chapter 18.
- **Chapter 4 –Roadside Design and Canals** (Charles Ramdatt) – Mr. Ramdatt suggested the language in Chapter 4 addressing canals be written to be no more restrictive than that found in other FDOT criteria. The following changes were approved:
  - Add the following sentence to the first paragraph in Section D.4 - Roadside Canals, “A canal is defined as an open ditch parallel to the roadway for a minimum distance of 1000 ft. and with a seasonal water depth in excess of 3 ft. for extended periods of time (24 hours or more)”.
  - Add the following to form the third paragraph in the Section D: “For rural and urban flush shoulder highways, the distance from the outside edge of the through travel lane to the top of the canal side slope nearest the road will be no less than 60 ft. for highways with design speeds of 50 mph or greater. For highways with design speeds less than 50 mph this minimum distance shall not be less than 50 ft. for rural and urban flush shoulder highways or 40 ft. for urban curb or curb and gutter highways. When new canal or roadway alignment is required, distances greater than those above should be provided, if possible, to accommodate possible future improvements to the roadway (widening, etc.). If the minimum standards for canal hazards cannot be met, then shielding should be considered.”
  - Add a third paragraph that reads “The RSAP is the recommended tool for evaluating the cost effectiveness of shielding roadside hazards.”Moved by Andy Tilton to approve the changes, seconded by Robert Behar. The changes were approved unanimously.

## **Chapter Chair Reports for Future Greenbook Revisions and Discussions**

- Following the breakout sessions for Chapter 6 – Roadway Lighting, Chapter 8 – Pedestrian Facilities, Chapter 9 – Bicycle Facilities, Chapter 11 – Work Zone Safety and Chapter 15 – Traffic Calming everyone reconvened.
  - Chapter 6 – Roadway Lighting: In addition to earlier discussion on the need to address street lighting in relation to transit facilities and crosswalks, Ron Chin asked about the practices between FDOT and local governments in providing street lighting, especially at intersections. The process varies regarding the types of facilities street lights can be added to (mast arms, strain poles, light poles), who funds the installation, whether there is a reimbursement for the cost to install, and how the long term electrical service is funded.
  - Chapters 8 and 9 – Pedestrian and Bicycle Facilities: The subcommittees, which met jointly, are interested in reviewing the National Association of Transportation Officials (NACTO) Urban Bikeway Design Guide. The committees will also look for opportunities to improve safety, especially at pedestrian crossings and in relation to transit facilities.

The team brainstormed and came up with a list of elements that could either be added or expanded. Elements included pedestrian bridges, mid-block crossings, refuge areas in medians, school zone issues, HAWK & RRFB, crosswalks, sidewalk connectivity, road diet discussions, new direction for bike lanes and pedestrian safety measures. This led to discussion on the structure of the two chapters and whether they should be combined. If combined a new chapter name would be created. Thoughts were Context Sensitive Design, Complete Streets, or another to be determined after content of chapter is defined.

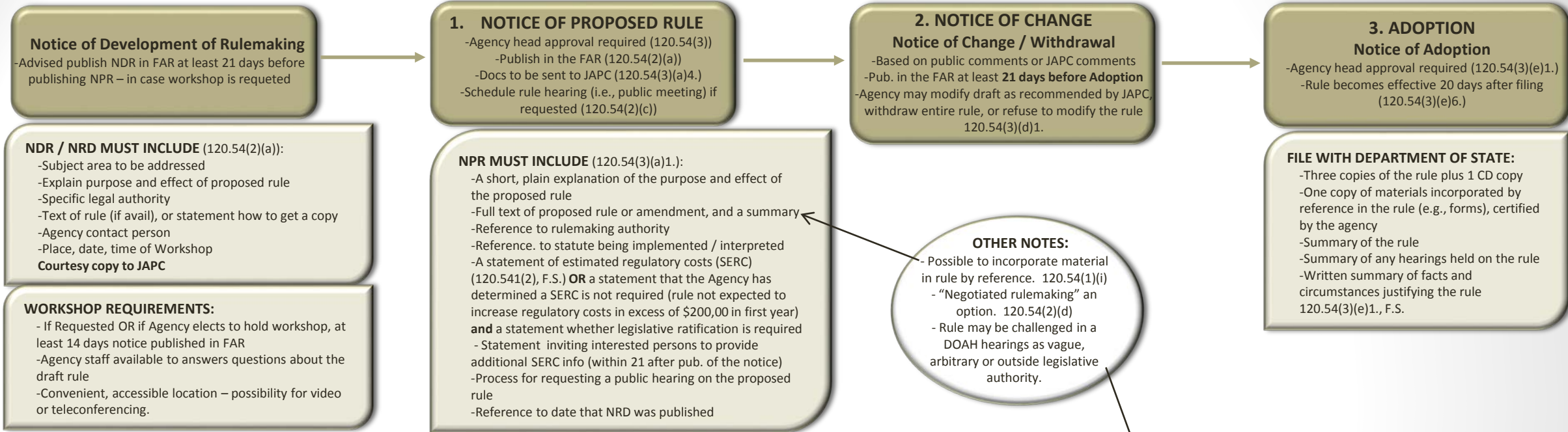
- Chapter 11 – Work Zone Safety: The subcommittee began by discussing MOT schemes for utility operations that may be less stringent than those provided in the MUTCD. However, they found no value in adding scenarios to the Greenbook that were already published elsewhere, and preferred not to provide a blanket approval to MOT schemes that did not meet the MUTCD's minimum requirements. David Kuhlman withdrew his request that alternate MOT schemes be added to the Greenbook. The subcommittee decided to look at the Chapter for other needed updates in 2015.
- Chapter 15 – Traffic Calming: The subcommittee generally feels the chapter is still on-target and provides use full information. They did recognize the need to update the references included in the chapter. Communities continue to receive requests from citizens and business areas for traffic calming.

## **Adjourn**

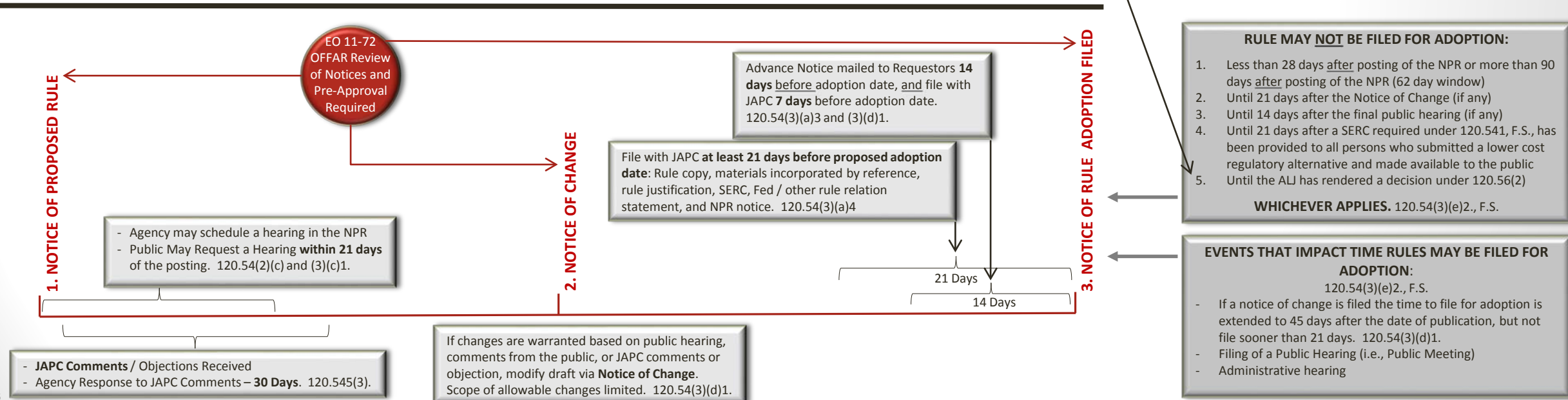
- The meeting adjourned at 11:15 AM.

# RULEMAKING – 2015

PROCESS



TIMELINE



## FLORIDA'S GOVERNMENT-IN-THE SUNSHINE LAW

### 1. THE LAW

Florida's Sunshine Law is found in Article I, Section 24, Florida Constitution and Chapter 286, Florida Statutes (F.S.), and applies to state agencies. The Sunshine Law is to be liberally construed; its exemptions are to be narrowly construed. Two or more people who are tasked with making a decision or recommendation constitute a "Board or Commission" under the Sunshine Law and are subject to its provisions. Section 286.011(1), F.S., states:

All meetings of any board or commission of any state agency . . . at which official acts are to be taken are declared to be public meetings open to the public at all times, and no resolution, rule, or formal action shall be considered binding except as taken or made at such meeting. **Members may discuss such business matters only at a public meeting.** . . .

The use of third persons or other means to evade the Sunshine Law is prohibited. The Sunshine Law does not generally apply to individual decision makers, fact finding, or general staff meetings.

### 2. BASIC PUBLIC MEETING REQUIREMENTS

#### A. Open, Accessible, Non-Discriminatory, Technology.

1) Pursuant to Section 286.26, F.S., public meetings must be open to the public, made accessible to individuals with physical handicaps, and held at locations that are easy to reach.

2) Pursuant to Section 286.011(6), F.S., public meetings are prohibited from being held at any location that discriminates on the basis of sex, race, age, creed, color, origin, or economic status, or operates in a manner as to unreasonably restrict public access.

3) Public meetings may include the use of teleconference, video, webinar, or other technology, but the public must be provided points of access. See Rule Chapter 28-109, F.A.C., regarding conducting proceedings by communications media technology.

B. Reasonable Notice. Pursuant to Section 286.011(1), F.S., reasonable notice of public meetings must be provided. Public meeting notices are published on the agency's website and other sources needed to reach affected persons. Less than 24 hours will not be considered reasonable notice except for emergency actions. Pursuant to Section 286.0105, F.S., notices of meetings must advise the public that a record of the meeting is required for an appeal of any decision made at the meeting, and that the person who wants to appeal a decision may need to ensure there is a verbatim record of the meeting. Meetings subject to Chapter 120, F.S., the Administrative Procedures Act, must also be published in the Florida Administrative Register no less than 7 days in advance. An agenda and recording is advisable.

C. Minutes. Pursuant to Section 286.011(2), F.S., minutes of public meetings must be taken, promptly recorded, and available for public inspection. The minutes may be posted or provided upon request. Recordings or transcripts are not required, but persons attending are permitted to record or videotape the meeting.

### 3. EXEMPTIONS

There are a limited number of exemptions to public meetings requirements under Section 286.0113, F.S.:

A. Meetings in which all or part of a security system plan would be revealed.



B. Procurements under Section 287.057, F.S., in which there are negotiations with a vendor or there are oral questions and answers of a vendor. As required by Section 286.0113(2), F.S., a complete recording of the negotiations or oral presentations must be made and no portion may be off the record. The recordings will be exempt from the public records requirement of Section 119.071(3)(a), F.S., until a notice of decision or intended decision is provided or 30 days after the bids, proposals, or final replies are opened.

#### 4. CONSEQUENCES OF SUNSHINE LAW VIOLATIONS

There are a number of consequences for failure to comply with the Sunshine Law:

A. Noncriminal penalties. A violation constitutes a noncriminal infraction and violators are subject to the imposition of a fine not to exceed \$500. Section 286.011(3)(a), F.S.

B. Criminal penalties. A knowing violation, occurring either within or outside the state, is a second degree misdemeanor, punishable under Section 775.082 or 775.083, F.S., which provide for up to 60 days in jail or a fine of \$500. Sections 286.011(3)(b) and (c), F.S.

C. Attorney's fees. In an action to enforce the Sunshine Law or to invalidate actions taken in violation of the Sunshine Law, attorney's fees will be assessed against the agency and may be assessed against individual members of the board or commission, including attorney's fees on appeal. Anyone filing such an action found to have done so in bad faith may also be assessed with attorney's fees. Section 286.011(4), F.S.

D. Injunctions. Circuit courts have jurisdiction to issue injunctions to enforce the Sunshine Law. Section 286.011(2), F.S.

E. Action Void. Actions taken at a meeting where the Sunshine Law was violated are void. Section 286.011(1), F.S. Only a full open hearing, meeting, or workshop can cure a Sunshine Law violation; a perfunctory ratification of actions taken will not suffice.

F. Removal from office. Section 112.52, F.S.

G. Loss of public confidence.

## CHAPTER 6

# ROADWAY LIGHTING

A	INTRODUCTION .....	6-1
B	OBJECTIVES .....	6-2
C	WARRANTING CONDITIONS.....	6-3
C.1	Criteria Based Upon Crash History .....	6-3
C.2	Criteria Based Upon Analysis and Investigation .....	6-3
C.3	General Criteria.....	6-4
D	TYPES OF ILLUMINATION.....	6-5
E	LEVEL OF ILLUMINATION .....	6-6
F	UNIFORMITY OF ILLUMINATION .....	6-10
G	UNDERPASSES and OVERPASSES .....	6-11
G.1	Daytime Lighting .....	6-11
G.2	Night Lighting.....	6-11
H	ADAPTIVE LIGHTING.....	6-11
I	MAINTENANCE .....	6-11
J	LIGHT POLES.....	6-13
K	REFERENCES.....	6-14
<del>6-16-26-36-36-36-46-56-66-96-106-106-106-106-106-126-</del>		
<del>13A</del>	<del>INTRODUCTION .....</del>	<del>6-1</del>
<del>B</del>	<del>OBJECTIVES .....</del>	<del>6-4</del>
<del>C</del>	<del>WARRANTING CONDITIONS.....</del>	<del>6-5</del>
<del>    C.1</del>	<del>Criteria Based Upon Crash History .....</del>	<del>6-5</del>
<del>    C.2</del>	<del>Criteria Based Upon Analysis and Investigation .....</del>	<del>6-5</del>
<del>    C.3</del>	<del>General Criteria.....</del>	<del>6-6</del>

D	LEVEL OF ILLUMINATION .....	6-7
E	UNIFORMITY OF ILLUMINATION .....	6-9
F	UNDERPASSES .....	6-12
F.1	Daytime Lighting .....	6-12
F.2	Night Lighting .....	6-12
G	MAINTENANCE .....	6-12
H	LIGHT POLES .....	6-13

## **TABLES**

<b><u>TABLE 7 – 1</u></b>	<b><u>LEVEL OF ILLUMINATION FOR STREETS AND HIGHWAYS.....</u></b>	<b><u>6-8</u></b>
<b><u>TABLE 7.2</u></b>	<b><u>ROAD SURFACE CLASSIFICATIONS.....</u></b>	<b><u>6.7</u></b>

**THIS PAGE INTENTIONALLY LEFT BLANK**

## CHAPTER 6

# ROADWAY LIGHTING

### A INTRODUCTION

The major reason for lighting streets and highways is to improve safety for vehicular and pedestrian traffic. Improvements in sight distance and reduction of confusion and distraction for night time driving can reduce the hazard potential on streets and highways. There is evidence indicating that highway lighting will produce an increase in highway capacity as well as improve the economic, safety, and aesthetic characteristics of highways.

Experience and technical improvements have resulted in improved design of lighting for streets and highways. Photometric data provide a basis for calculation of the illumination at any point for various combinations of selected luminaire types, heights, and locations. Lighting engineers can develop a lighting system that will comply with the requirements for level and uniformity of illumination; however, some uncertainties preclude the adoption of rigid design standards. Among these uncertainties is the lack of understanding in the area of driver response and behavior under various lighting conditions. The design of lighting for new streets and highways, as well as improvements on existing facilities, should be accompanied by careful consideration of the variables involved in driver behavior and problems peculiar to particular locations.

Rights of way with pedestrian sidewalks and/or bikeways adjacent to the roadway should first address lighting requirements for the roadway to assure it is continuously illuminated. Additional lighting for a sidewalk or shared use path may be necessary if it is substantially set back from the roadway, at the discretion of the responsible/maintaining agency. Pedestrian sidewalks and/or bikeways should not be illuminated in lieu of lighting the adjacent roadway in order to avoid glare or potential lighting distractions to drivers.

## B OBJECTIVES

The objective for providing roadway lighting is to improve the safety of roadways, sidewalks, and shared use paths and visibility of signs for road users (drivers, pedestrians, and bicyclists)~~the reduction of particular hazards confronting motorists and pedestrians on the roadway.~~ The achievement of this objective will be aided by meeting these specific goals~~objectives~~:

- Provide ~~the (driver) with~~ an improved view of the general highway roadway geometry and the adjacent environment.
- Increase the sight distance of road users drivers to improve response to hazards and decision points.
- ~~Improve the mutual view of motorists, bicyclists and pedestrians.~~
- Eliminate "blind" spots unique~~peculiar~~ to travel at night or in low light conditions~~driving~~.
- Provide a clearer view of the general situation during police, emergency, maintenance, and construction operations.
- Provide assistance in roadway, sidewalk or path delineation, particularly in the presence of confusing background lighting (i.e., surrounding street and other area lighting confuses the driver on an unlighted street or highway).
- Minimize~~Eliminate~~ glare that is discomforting or disabling ~~to the driver~~.
- Reduce~~Avoid~~ abrupt changes in light intensity.
- ~~Provide maintenance capabilities and procedures that will minimize hazards to motorists.~~
- Avoid the introduction of roadside hazards resulting from improper placement of light poles, pull boxes, etc. (as covered under CHAPTER 3 - GEOMETRIC DESIGN and CHAPTER 4 - ROADSIDE DESIGN).

## C WARRANTING CONDITIONS

Although precise warrants for the provision of roadway lighting are difficult to determine, criteria for lighting is established and should be followed for construction and for improvement of existing facilities. The following locations should be considered as a basis for warranting roadway lighting:

### C.1 Criteria Based Upon Crash History

- Locations where pedestrians assemble to board or depart from transit services.
- Locations that, by ~~an~~ crash ~~accident~~ investigation program, have been shown to be hazardous due to inadequate lighting.
- Locations where the night/day ratio of serious crashes is higher than the average of similar locations.
- Specific locations that have a significant number of night time crashes and where a large percentage of these night time crashes result in injuries or fatalities.

### C.2 Criteria Based Upon Analysis and Investigation

- Locations requiring a rapid sequence of decisions by the road user ~~driver~~.
- Locations where night sight distance problems exist, with particular consideration to ~~vehicle~~ headlight limitations (i.e., where vertical and horizontal curvature adversely affect illumination by headlamps).
- Locations having discomforting or disabling glare.
- Locations where background lighting exists, particularly if this could be distracting or confusing to the road user ~~driver~~.
- Locations where improved delineation of the highway ~~roadway~~ alignment is needed.

### C.3 General Criteria

- ~~Freeways, expressways, and major streets and highways in urban areas.~~
- ~~Freeways with frequent (½ mile from "on" ramp to "off" ramp) interchanges.~~
- ~~Freeways with high volume and speed.~~
- ~~Freeway interchanges including ramps and approach roadways.~~
- ~~Acceleration and deceleration lanes.~~
- ~~Rest areas.~~
- ~~Junctions of freeways and major highways in rural areas~~
- Roundabouts.
- Urban collector streets, particularly with high speed, high volumes, or frequent turning movements.
- Urban streets of any category experiencing high night time volumes or speeds or that have frequent signalization or turning movements.
- Areas frequently congested with vehicular and/or pedestrian traffic.
- Pedestrian and bicyclist crossings (intersections or mid-block locations), and areas such as entertainment districts, sporting arenas, shopping centers, beach access, parks, and other locations that generate attract higher volumes of pedestrian activity.
- Schools, churches, transit bus stops, or other pedestrian or bicycliste generators.
- High density land use areas.
- Central business districts.
- Junctions of major highways in rural areas.
- Rest areas/picnic shelters/trail heads/recreational facilities.



## D TYPES OF ILLUMINATION

- High Pressure Sodium (HPS) Lamps – is the most commonly used light source for street lighting. Light produced by HPS lamps has a correlated color temperature (CCT) around 2100°K which is a warm yellow color. The average rated life for an HPS lamp is from 24,000 to 30,000 hours. HPS lamps have a very high initial luminous efficacy of over 100 lumens per watt.
- Metal Halide (MH) Lamps – is commonly used for overhead lighting of commercial parking lots, sports facilities, retail stores and street lighting. Light produced by MH lamps has a CCT of 3800°K to 4000°K which is a white color. The average rated life of a MH lamp can vary from 9,000 to 20,000 hours. MH lamps have a high initial luminous efficacy of around 75 - 100 lumens per watt.
- Light Emitting Diode (LED) – although LED was developed in the early 1960s, it has only recently entered the roadway lighting market. Light produced by LED lamps have a CCT of 4000°K to 6000°K which is a white to bluish color. The average rated life for LED can vary from 50,000 to 100,000 hours. The wide variation in rated life for LED's is due to the limited lumen output of a single LED. To provide sufficient lumens for roadway lighting requires that fixtures have a large number of LED's. To maximize the lumen output of each LED, fixture manufactures may use a variety of techniques to increase the lumen output such as increasing the CCT and increasing the drive current. Increasing the CCT from 3500°K to 4500°K results in an 8% increase in lumen level, however above 4500°K the rate of increase doubles. Increasing the CCT also improves the efficacy of LED's. LED's are most efficient at drive currents of 350mA or 525mA, however they can be driven as high as 2100-mA. A 25% increase in lumen level can be achieved by increasing the drive current from 525mA to 700mA. The increase in lumen level drops slightly to 21% for each 175mA increase from 700mA to 1400mA. Above 1400mA, the increase in lumen level drops to 6% for each 175mA. Increasing the drive current to LED's has two serious consequences, it substantially reduces the average rated life and the efficiency of the LED. To provide sufficient lumen levels for roadway applications, most LED fixtures have an initial luminous efficacy of around 75 lumens per watt.

## ED LEVEL OF ILLUMINATION

It is recommended that the level of illumination for streets and highways not be less than:

- Levels consistent with need and resources.
- Guidelines established by AASHTO – Roadway Lighting Design Guide found in Table 7.1 -Level of Illumination for Streets and Highways on the following page.
- Lighting of mid-block pedestrian crossings at 2.3 foot candles of vertical illumination should be provided when night time pedestrian activity is expected.

When adding supplemental lighting for pedestrian activity, ensure lighting is compatible with any existing lighting in the corridor and minimizes glare. See Table 7.1 for ranges of illumination.

Luminance in roadway lighting is a measure of the reflected light from the pavement surface that is visible to the motorist’s eye. A system of pavement reflectance values divides the pavement characteristics into four categories: R1, R2, R3 and R4. These categories are based upon the **American National Standard Practice for Roadway Lighting** and have been adopted by **AASHTO** in their **Roadway Lighting Design Guide**. They are described in Table 7.2 Road Surface Classifications.

**TABLE 7.2 ROAD SURFACE CLASSIFICATIONS**

<u>Class</u>	<u>Q<sub>0</sub>*</u>	<u>Description</u>	<u>Mode of Reflectance</u>
<u>R1</u>	<u>0.10</u>	<u>Portland cement concrete road surface. Asphalt road surface with a minimum of 12% of the aggregates composed of artificial brightener or aggregates.</u>	<u>Mostly diffuse</u>
<u>R2</u>	<u>0.07</u>	<u>Asphalt road surface with an aggregate composed of minimum 60% gravel (size greater than 0.4 in.). Asphalt road surface with 10 to 15% artificial brightener in aggregate mix. (Not normally used in North America).</u>	<u>Mixed (diffuse and specular)</u>
<u>R3</u>	<u>0.07</u>	<u>Asphalt road surface (regular and carpet seal) with dark aggregates (e.g., trap rock, blast furnace slag); rough texture after some months of use typical highways).</u>	<u>Slightly specular.</u>
<u>R4</u>	<u>0.08</u>	<u>Asphalt road surface with very smooth texture.</u>	<u>Mostly specular.</u>

\* Q<sub>0</sub> = representative mean luminance coefficient.

Topic # 625-000-015  
Manual of Uniform Minimum Standards  
for Design, Construction and Maintenance  
for Streets and Highways

~~Draft - May 2015~~

~~Revised March 23 February 26 430/9/20154~~

These levels are for the purpose of highway safety and do not apply to lighting levels required for crime reduction. Further information may be found in the AASHTO - Roadway Lighting Design Guide (2005).

**TABLE 7 – 1**  
**LEVEL OF ILLUMINATION FOR STREETS AND HIGHWAYS**

Roadway and Walkway Classification	Off-Roadway Light Sources	Illuminance Method					Luminance Method			Additional Values (both Methods)
		Average Maintained Illuminance (Horizontal)				Illuminance Uniformity Ratio	Average Maintained Luminance			Veiling Luminance Ratio
		R1	R2	R3	R4		Lavg	Uniformity		
General Land Use	(foot-candles) (min)	(foot-candles) (min)	(foot-candles) (min)	(foot-candles) (min)	avg/min (max) (6)	cd/m <sup>2</sup> (min)	Lavg/Lmin (max)	Lmax/Lmin (max) <sup>9</sup>	Lv(max)/Lavg (max) <sup>(3)</sup>	
Other Principal Arterials (partial or no control of access)	Commercial	1.1	1.6	1.6	1.4	3:1	1.2	3:1	5:1	0.3:1
	Intermediate	0.8	1.2	1.2	1.0	3:1	0.9	3:1	5:1	0.3:1
	Residential	0.6	0.8	0.8	0.8	3:1	0.6	3.5:1	6:1	0.3:1
Minor Arterials	Commercial	0.9	1.4	1.4	1.0	4:1	1.2	3:1	5:1	0.3:1
	Intermediate	0.8	1.0	1.0	0.9	4:1	0.9	3:1	5:1	0.3:1
	Residential	0.5	0.7	0.7	0.7	4:1	0.6	3.5:1	6:1	0.3:1
Collectors	Commercial	0.8	1.1	1.1	0.9	4:1	0.8	3:1	5:1	0.4:1
	Intermediate	0.6	0.8	0.8	0.8	4:1	0.6	3.5:1	6:1	0.4:1
	Residential	0.4	0.6	0.6	0.5	4:1	0.4	4:1	8:1	0.4:1
Local	Commercial	0.6	0.8	0.8	0.8	6:1	0.6	6:1	10:1	0.4:1
	Intermediate	0.5	0.7	0.7	0.6	6:1	0.5	6:1	10:1	0.4:1
	Residential	0.3	0.4	0.4	0.4	6:1	0.3	6:1	10:1	0.4:1
Alleys	Commercial	0.4	0.6	0.6	0.5	6:1	0.4	6:1	10:1	0.4:1
	Intermediate	0.3	0.4	0.4	0.4	6:1	0.3	6:1	10:1	0.4:1
	Residential	0.2	0.3	0.3	0.3	6:1	0.2	6:1	10:1	0.4:1

**TABLE 7 – 1**  
**LEVEL OF ILLUMINATION FOR STREETS AND HIGHWAYS**  
 (Continued)

<u>Sidewalks</u>	<u>Commercial</u>	<u>0.9</u>	<u>1.3</u>	<u>1.3</u>	<u>1.2</u>	<u>3:1</u>	<u>Use illuminance requirements</u>
	<u>Intermediate</u>	<u>0.6</u>	<u>0.8</u>	<u>0.8</u>	<u>0.8</u>	<u>4:1</u>	
	<u>Residential</u>	<u>0.3</u>	<u>0.4</u>	<u>0.4</u>	<u>0.4</u>	<u>6:1</u>	
<u>Pedestrian Ways and Bicycle Ways<sup>(2)</sup></u>	<u>All</u>	<u>1.4</u>	<u>2.0</u>	<u>2.0</u>	<u>1.8</u>	<u>3.1</u>	
<u>Notes</u>	<ol style="list-style-type: none"> <li>1. <u>Meet either the Illuminance design method requirements or the Luminance design method requirements and meet veiling luminance requirements for both illuminance and Luminance design methods.</u></li> <li>2. <u>Assumes a separate facility. For Pedestrian Ways and Bicycle Ways adjacent to roadway, use roadway design values. Use R3 requirements for walkway/bikeway surface materials other than the pavement types shown.</u></li> <li>3. <u>Lv (max) refers to the maximum point along the pavement, not the maximum in lamp life. The Maintenance factor applies to both the Lv term and the Lavg term.</u></li> <li>4. <u>There may be situations when a higher level of illuminance is justified. The higher values for freeways may be justified when deemed advantageous by the agency to mitigate off-roadway sources.</u></li> <li>5. <u>Physical roadway conditions may require adjustment of spacing determined from the base levels of illuminance indicated above.</u></li> <li>6. <u>Higher uniformity ratios are acceptable for elevated ramps near high-mast poles.</u></li> <li>7. <u>See AASHTO publication entitled, "A Policy on Geometric Design of Highways and Streets" for roadway and walkway classifications.</u></li> <li>8. <u>R1, R2, R3 and R4 are Road Surface Classifications, defined in the AASHTO Roadway Lighting Design Guide.</u></li> </ol>						

## **FE** UNIFORMITY OF ILLUMINATION

In order to avoid vision problems due to varying illumination, it is important to maintain illumination uniformity over the roadway. It is recommended the ratio of the average to the minimum initial illumination on the roadway be between 3:1 to 4:1.

A maximum to minimum uniformity ratio of 10:1 should not be exceeded. It is important to allow time for the driver's eye to adjust to lower light levels. The first light poles should be located on the side of the incoming traffic approaching the illuminated area. The eye can adjust to increased or increasing light level more quickly. In transition from a lighted to an unlighted portion of the highways, the level should be gradually reduced from the level maintained on the lighted section. This may be accomplished by having the last light pole occur on the opposite roadway. The roadway section following lighting termination should be free of hazards or decision points. Lighting should not be terminated before changes in background lighting or roadway geometry, or at the location of traffic control devices.

It is also important to ensure color consistency when lighting a highway/pedestrian corridor, ~~as white and yellow conflict with each other.~~ For roadway lighting mixing of HPS and LED will reduce the lighting uniformity. As we transition from HPS to LED, it is acceptable to have segments along the same corridor lighted with HPS and LED.

The use of spot lighting at unlit intersections with a history of nighttime crashes is an option.

Close coordination between the Engineer of Record and the responsible local governmental agency is essential ~~when utilizing this approach.~~

## **GF UNDERPASSES and OVERPASSES**

One of the criteria to be followed to determine requirements for underpass lighting is the relative level between illumination on the roadway inside and outside of the underpass. The height, width, and length of the underpass determines the amount of light penetration from the exterior.

Lighting of independent sidewalks or shared use paths should be evaluated on a project specific basis. Considerations include if night time use is likely, the role of the facility in the community's bicycle and pedestrian network and whether alternatives are available for night time travel.

### **GF.1 Daytime Lighting**

A gradual decrease in the illumination level from day time level on the roadway, sidewalk or path to the underpass should be provided. Supplemental day time lighting is normally not needed in underpasses less than 100 feet in length.

### **GF.2 Night Lighting**

The night time illumination level in the underpass should be maintained near the night time level of the approach roadway, sidewalk or path. Due to relatively low luminaire mounting heights, care should be exercised to avoid glare.

## **HG ADAPTIVE LIGHTING**

Some locations, such as coastal roadways where sea turtles may be affected may require lower lighting levels and colors than what might normally be provided. The Guidelines for the Implementation of Reduced Lighting on Roadways, FHWA provide a process by which an agency or a lighting designer can select the required lighting level for a road or street and implement adaptive lighting for a lighting installation or lighting retrofit. This document supplements existing lighting guidelines.

## **I MAINTENANCE**

A program of regular preventive maintenance should be established to ensure levels of illumination do not go below required values. The program should be coordinated with lighting design to determine the maintenance period. Factors for consideration include a

decrease in lamp output, luminaire components becoming dirty, and the physical deterioration of the reflector or refractor. The maintenance of roadway lighting should be incorporated in the overall maintenance program specified in CHAPTER 10 ~~MAINTENANCE~~ AND RESURFACING.



## **JH** LIGHT POLES

Light poles should not be placed in the sidewalk when adequate right of way is available beyond the sidewalk. Placement of lighting structures and achieved illumination may be limited by existing conditions, such as driveways, overhead and underground utilities, drainage structures, and availability of right of way.

Light poles should not be placed so as to provide a hazard to out of control vehicles. Light poles that are generally not of a breakaway design or frangible and should be placed outside of the clear zone roadway recovery area. They should be as far removed from the travel lane as possible or behind adequate guardrail or other barriers. Light poles should be placed on the inside of the curves when feasible. Foundations or light poles and rigid auxiliary lighting components that are not behind suitable barriers should be constructed flush with or below the ground level. Breakaway light poles should not be used where there is a high probability that a falling light pole may strike a pedestrian or fall on a building or the roadway and create a greater hazard.

The use of high mast lighting should be considered, particularly for lighting interchanges and other large plaza areas. This use tends to produce a more uniform illumination level, reduces glare, and allows placement of the light poles farther from the roadway. Additional emphasis lighting should be considered to illuminate specific and desired pedestrian crossings.

The placement of light poles should not interfere with the road users ?? driver's sight distance nor the view of signs, signals, or other traffic control devices. Further criteria regarding the placement of roadside structures, including light poles, is specified in CHAPTER 4 - ROADSIDE DESIGN.

Placement of lighting structures and achieved illumination may be limited by existing conditions, such as driveways, overhead and underground utilities, drainage structures, and availability of right of way.

## **K REFERENCES**

The publications referenced in this chapter can be obtained at the following web sites.

- Roadway Lighting, ANSI/RP-8-14  
<http://www.ies.org/store/product/roadway-lighting-ansiies-rp814-1350.cfm>
- AASHTO - Roadway Lighting Design Guide  
<https://bookstore.transportation.org>
- Guidelines for the Implementation of Reduced Lighting on Roadways  
PUBLICATION NO. FHWA-HRT-14-050 JUNE 2014  
<http://www.fhwa.dot.gov/publications/research/safety/14050/14050.pdf>

## CHAPTER 8

### PEDESTRIAN FACILITIES

<b>A</b>	<b>INTRODUCTION</b>	<b>8-1</b>
<b>B</b>	<b>TYPES OF PEDESTRIAN FACILITIES</b>	<b>8-1</b>
<b>B.1</b>	<b>Sidewalks</b>	<b>8-1</b>
<b>B.3</b>	<b>Shared Streets</b>	<b>8-3</b>
<b>B.4</b>	<b>Shoulders</b>	<b>8-3</b>
<b>C</b>	<b>MINIMIZING CONFLICTS</b>	<b>8-4</b>
<b>C.1</b>	<b>General Needs</b>	<b>8-4</b>
<b>C.2</b>	<b>Horizontal Separation</b>	<b>8-5</b>
<b>C.2.a</b>	<b>General Criteria</b>	<b>8-5</b>
<b>C.3.b</b>	<b>Buffer Widths</b>	<b>8-6</b>
<b>C.4</b>	<b>Other Considerations</b>	<b>8-8</b>
<b>D</b>	<b>BARRIER SEPARATION</b>	<b>8-9</b>
<b>D.1</b>	<b>Longitudinal Barriers</b>	<b>8-9</b>
<b>D.2</b>	<b>Fencing, Pedestrian Channelization Devices or Landscaping</b>	<b>8-9</b>
<b>E</b>	<b>GRADE SEPARATION</b>	<b>8-11</b>
<b>E.1</b>	<b>Overpasses</b>	<b>8-12</b>
<b>E.2</b>	<b>Underpasses</b>	<b>8-12</b>
<b>F</b>	<b>DROP-OFF HAZARDS FOR PEDESTRIANS</b>	<b>8-13</b>
<b>G</b>	<b>PEDESTRIAN CROSSINGS</b>	<b>8-15</b>
<b>G.1</b>	<b>Crosswalks</b>	<b>8-15</b>
<b>G.1.a</b>	<b>Marked Crosswalks</b>	<b>8-15</b>
<b>G.1.b</b>	<b>Midblock Crosswalks</b>	<b>8-18</b>
<b>G.2</b>	<b>Curb Ramps</b>	<b>8-21</b>
<b>G.3</b>	<b>Controls</b>	<b>8-22</b>
<b>G.4</b>	<b>Sight Distance</b>	<b>8-22</b>
<b>G.5</b>	<b>Railroad Crossings</b>	<b>8-22</b>

<b>H</b>	<b>LIGHTING</b>	<b>8-23</b>
<b>I</b>	<b>REFERENCES FOR INFORMATIONAL PURPOSES</b>	<b>8-24</b>
<b>A</b>	<b>INTRODUCTION</b>	
<b>B</b>	<b>TYPES OF PEDESTRIAN FACILITIES</b>	
B.1	Sidewalks	8-1
B.2	Off-Road Paths	8-2
B.3	Shared-Use Paths	8-2
B.4	Shared Streets	8-2
B.5	Shoulders	8-2
<b>C</b>	<b>MINIMIZING CONFLICTS</b>	<b>8-2</b>
C.1	General Needs	8-3
C.2	Independent Systems	8-3
C.3	Horizontal Separation	8-4
C.3.a	General Criteria	8-4
C.3.b	Buffer Widths	8-4
C.4	Other Considerations	8-5
<b>D</b>	<b>BARRIER SEPARATION</b>	<b>8-6</b>
D.1	Longitudinal Barriers	8-6
D.2	Fencing or Landscaping	8-6
<b>E</b>	<b>VERTICAL SEPARATION</b>	<b>8-7</b>
E.1	Overpasses	8-7
E.2	Underpasses	8-7
<b>F</b>	<b>PEDESTRIAN CROSSINGS</b>	<b>8-8</b>
F.1	Crosswalks	8-8
F.1.a	Marked Crosswalks	8-8
F.1.b	Midblock Crosswalks	8-9
F.1.c	Crossing Distance Considerations	8-9
F.2	Curb Ramps	8-9
F.3	Controls	8-10
F.4	Sight Distance	8-10

F.5	Lighting	8-11
G	REFERENCES FOR INFORMATIONAL PURPOSES	8-12
A	INTRODUCTION	8-1
B	TYPES OF PEDESTRIAN FACILITIES	8-1
B.1	Sidewalks	8-1
B.2	Off-Road Paths	8-2
B.3	Shared-Use Paths	8-2
B.4	Shared Streets	8-2
B.5	Shoulders	8-2
C	MINIMIZING CONFLICTS	8-2
C.1	General Needs	8-3
C.2	Independent Systems	8-3
C.3	Horizontal Separation	8-4
C.3.a	General Criteria	8-4
C.3.b	Buffer Widths	8-4
C.4	Other Considerations	8-5
D	BARRIER SEPARATION	8-6
D.1	Longitudinal Barriers	8-6
D.2	Fencing or Landscaping	8-6
E	VERTICAL SEPARATION	8-7
E.1	Overpasses	8-7
E.2	Underpasses	8-7
F	PEDESTRIAN CROSSINGS	8-8
F.1	Crosswalks	8-8
F.1.a	Marked Crosswalks	8-8
F.1.b	Midblock Crosswalks	8-9
F.1.c	Crossing Distance Considerations	8-9
F.2	Curb Ramps	8-9
F.3	Controls	8-10
F.4	Sight Distance	8-10

## CHAPTER 8

# PEDESTRIAN FACILITIES

### A INTRODUCTION

Pedestrian facilities shall be given full consideration in the planning and development of transportation facilities, including the incorporation of such facilities into state, regional, and local transportation plans and programs under the assumption that transportation facilities will be used by pedestrians. Pedestrian facilities should be considered in conjunction with the construction, reconstruction, or other significant improvement of any transportation facility. Special emphasis should be given to projects in or within 1 mile of an urban area.

Each highway agency responsible for a system of streets and highways should establish and maintain a program for implementing pedestrian facilities, and for maintaining existing pedestrian facilities.

### B TYPES OF PEDESTRIAN FACILITIES

There are several ways in which pedestrians can be accommodated in the public right of way. The 2006 Americans with Disabilities Act – Standards for Transportation Facilities and the 2012 Florida Accessibility Code impose additional requirements for the design and construction of curb ramps and pedestrian facilities.

#### B.1 Sidewalks

Sidewalks are walkways parallel to the roadway and designed for use by pedestrians. Sidewalks should be provided along both sides of roadways that are in or within one mile of an urban area. If sidewalks are constructed on the approaches to bridges, they should be continued across the structure. If continuous sidewalks are constructed on only one side of the street, pedestrians should be provided access to facilities and services located on the opposite side of the street. ~~Sidewalks provided on both sides of a street are the preferred pedestrian facility; however, the construction of sidewalks on both sides of the street would not be required in cases where pedestrians would not be expected such as when the roadway parallels a railroad or drainage canal.~~ To comply with ADA standards, newly constructed, reconstructed, or altered sidewalks ~~shall~~ must

be accessible to and usable by persons with disabilities.

The minimum width of a sidewalk shall be 5 feet on both curb and gutter and flush shoulder roadways. The minimum separation for a 5-foot sidewalk from the back of curb is 2 feet. If the sidewalk is located adjacent to the curb, the minimum width of sidewalk is 6 feet. For sidewalks not adjacent to the curb, at least a 1-foot wide graded area should be provided on both sides, flush with the sidewalk and having a maximum 1:6 slope. Wider sidewalks should be considered in Central Business Districts and in areas where heavy two-way pedestrian traffic is expected. A 5-foot wide (minimum) sidewalk that connects a transit stop or facility with an existing sidewalk or shared use path shall be included to comply with ADA accessibility standards.

Particular attention shall be given to pedestrian accommodations at the termini of each project. If full accommodations cannot be provided due to the limited scope or an existing sidewalk is not present at the termini, the designer should extend the sidewalk to the next appropriate pedestrian crossing or access point. If pedestrian facilities are provided, they shall be connected with facilities on the adjoining projects.

For new construction and reconstructed roadways, grades on sidewalks or shared use paths shall not exceed 5%, unless accessible ramps and landings are provided. However, in a roadway right of way, the grade of sidewalks or shared use paths is permitted to equal the general grade established for the adjacent street or highway. There should be enough sidewalk or path cross slope to allow for adequate drainage, however the maximum shall be no more than 2% to comply with ADA requirements.

Where existing physical constraints make it impracticable for altered elements, spaces, or facilities to fully comply with the requirements for new construction, compliance is required to the extent practicable within the scope of the project. Existing physical constraints include, but are not limited to, underlying terrain, right-of-way availability, underground structures, adjacent developed facilities, drainage, or the presence of a notable natural or historic feature.

Additional information on designing accessible pedestrian facilities is provided by the United States Access Board at the following web site:

<http://www.access-board.gov/guidelines-and-standards/streets-sidewalks/public-rights-of-way/proposed-rights-of-way-guidelines/major-issues>

A clear 1-foot wide graded area with a maximum 1:6 slope should be provided adjacent to the sidewalk, except where adjacent to a roadway curb. Edge drop-offs should be avoided. When drop-offs cannot be avoided, they should be shielded as discussed in Section F, DROP-OFF HAZARDS FOR PEDESTRIANS.

For additional information concerning the design of sidewalks, refer to Section C.7.d of CHAPTER 3 – GEOMETRIC DESIGN.

## **B.2** ~~Off-Road Paths~~

~~An off-road path, paved or unpaved, can be an appropriate facility in rural or low-density suburban areas. Paths are usually set back from the road and separated by a green area, ditch, swales or trees.~~

### **B.23** Shared-Use Paths

Paths are usually set back from the road and separated by a green area, ditch, swales or trees. Shared use paths are designed for the use by both pedestrians and bicyclists and shall meet ADA Standards.

For additional information concerning the design of shared-use paths, refer to CHAPTER 9 - BICYCLE FACILITIES.

### **B.34** Shared Streets

Shared uses of a street for people walking, bicycling and driving are referred to as shared streets. These are usually specially designed spaces such as pedestrian streets which are ~~used on~~ local urban streets with extremely low vehicle speed.

### **B.45** Shoulders

~~Most~~ Highway shoulders are ~~not pedestrian facilities, because they are~~ not intended for frequent use by pedestrians, ~~but do~~ although they can accommodate occasional pedestrian traffic usage. Highway shoulders often have cross slopes which exceed 2%; consequently they are not considered or expected to fully meet ADA criteria.



## C MINIMIZING CONFLICTS

The planning and design of new streets and highways shall include provisions that support pedestrian travel and minimize vehicle-pedestrian conflicts. These include:

- Sidewalks and/or shared use paths parallel to the roadway
- Marked pedestrian crossings
- ~~Detectable warnings at roadway and major driveway connections~~
- Raised median or refuge islands
- Pedestrian signal features such as pedestrian signal heads and detectors~~walk lights and push buttons~~
- Transit stops and shelters
- ~~Commuter and light rail,~~
- ~~Bus rapid transit (BRT)~~

In some situations it may be possible to eliminate a vehicle-pedestrian conflict through. ~~The elimination of vehicle-pedestrian conflict points requires~~ close coordination with the planning of pedestrian facilities~~pathways~~ and activity outside of the highway right of way. Care should be exercised to ensure the elimination of a given conflict point does not transfer the problem to a different location. ~~A reduction in the number of conflict points allows for economical and effective control and protection at the remaining conflict points, thus providing an efficient method of pedestrian hazard reduction. Procedures for the elimination of vehicle-pedestrian conflicts are given in the subsequent material.~~

Any effort to minimize or eliminate conflict points must consider the mobility needs of the pedestrian. The desired travel path should not be severed and the number of required crossing points and/or walking distances should not be significantly increased. Some ~~crossings~~~~conflict points~~ should~~will have to~~ be redesigned rather than eliminated or relocated.

### C.1 General Needs

Minimizing vehicle-pedestrian conflicts can be accomplished by providing adequate horizontal, physical, or vertical (primarily for crossings) separation between the roadway and the pedestrian facility~~pathways~~.

## C.2—Independent Systems

One ideal method for eliminating vehicle-pedestrian conflicts is to provide essentially independent systems for vehicular and pedestrian traffic. This requires adequate land use allocation and restriction (CHAPTER 2—LAND DEVELOPMENT) and the proper layout and design of pedestrian pathways and the surface transportation network.

Where independent systems are provided, intersections between the two modes (i.e., parking areas) are still required. Due to the small number of these intersections or conflict points, they can be economically developed for safe and efficient operation.

### C.2.3 Horizontal Separation

The development of independent systems for pedestrian and motor vehicular traffic is the preferred method for providing adequate horizontal separation.

#### C.2.3.a General Criteria

New sidewalks shall be placed as far from the roadway as practical in the following sequence of desirability:

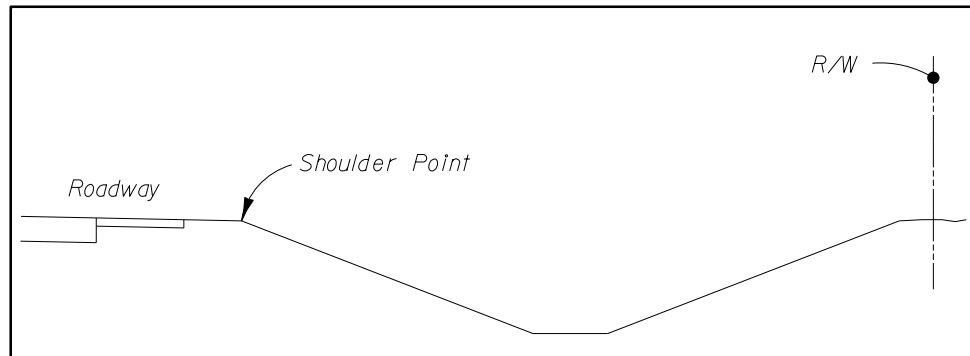
1. As near the right of way line as possible.
2. Outside of the clear zone.
3. Sufficiently off-set from the curb to allow for the placement of street trees, signs, utilities, parking meters, benches or other street furniture outside of the sidewalk in urban locations (e.g. town center, business or entertainment district).
4. Five feet from the shoulder point on flush shoulder roadways.
5. At the grass shoulder point of flush shoulder roadways.

Figure 8.1 provides an illustration of the location of the shoulder point.

On arterial or collector roadways, sidewalks shall not be constructed contiguous to the roadway pavement, unless a curb or other barrier is provided. Nearing intersections, the sidewalk should be transitioned as necessary to provide a more functional crossing location that also meets

driver expectation. Further guidance on the placement of stop or yield lines and crosswalks is provided in the *MUTCD, Part 3.*

**FIGURE 8-1 SHOULDER POINT**



~~Pedestrian pathways should be placed as far from the roadway as practical, as shown by the following criteria, which are given in a sequence of desirability:~~

- ~~• Outside of the right of way in a separately dedicated corridor adjacent to the right of way~~
- ~~• At or near the right of way line (ideally, 3 feet of width should be provided behind the sidewalk for above ground utilities)~~
- ~~• Outside of the minimum required clear zone (CHAPTER 3 GEOMETRIC DESIGN Table 3-12)~~
- ~~• As far from the edge of the driving lane as practical~~

~~Sidewalk alignments, which are set back from the roadway, should taper for alignment closer to the roadway at intersections. This will allow for coordinated placement of crosswalks and stop bars.~~

### **C.3.b Buffer Widths**

Providing a buffer can improve pedestrian safety and enhance the overall walking experience. Buffer width is defined as the space between the sidewalk and the edge of traveled way. On-street parking or bike lanes can also act as an additional buffer. ~~When separated from the curb, the minimum separation for a sidewalk from the back of curb is 2 feet.~~ The planting strip or buffer strip should be 6 feet where practical to eliminate the

need to narrow or reroute sidewalks around driveways. With this wider buffer strip, the sidewalk is placed far enough back so that the driveway slope does not have to encroach into the sidewalk. ~~Wider sidewalks should be considered in Central Business Districts and in areas where heavy two-way pedestrian traffic is expected.~~

## C.4 Other Considerations

When designing urban highways, ~~with substantial pedestrian-vehicle conflict points,~~ the following ~~are~~ measures ~~that~~ may be considered to help ~~reduce these conflicts and~~ increase the safe and efficient operation of the ~~highway roadway for~~ pedestrians:

- Use narrower lanes and introduce raised medians to provide pedestrian refuge areas
- Provide pedestrian signal features and detectors
- Prohibit right turn on red
- Control, reduce, or eliminate left and/or right turns
- Prohibit free flow right turn movements
- ~~Prohibit right turn on red~~
- Reduce the number of lanes
- ~~Use narrower lanes and introduce raised medians to provide pedestrian refuge areas~~
- Provide pedestrian signal features
- ~~Provide pedestrian grade separations~~

## D BARRIER SEPARATION

Barriers may be used to assist in the separation of motor vehicular and pedestrian traffic.

### D.1 Longitudinal Barriers

Longitudinal barriers such as guardrails, rigid barriers, and bridge railings are designed primarily to redirect errant vehicles away from roadside hazards. These barriers can also be used to provide valuable protection of pedestrian facilities ~~pathways~~ from out of control vehicles.

Where adequate horizontal separation is not feasible, or where there is a significant hazard from out of control vehicles, longitudinal barriers may be utilized. If electing to use barriers, special consideration should be made to ensure proper sight distance near driveways and intersections is maintained. Figure 8.2 illustrates the correct placement of a sidewalk in conjunction with a guardrail.

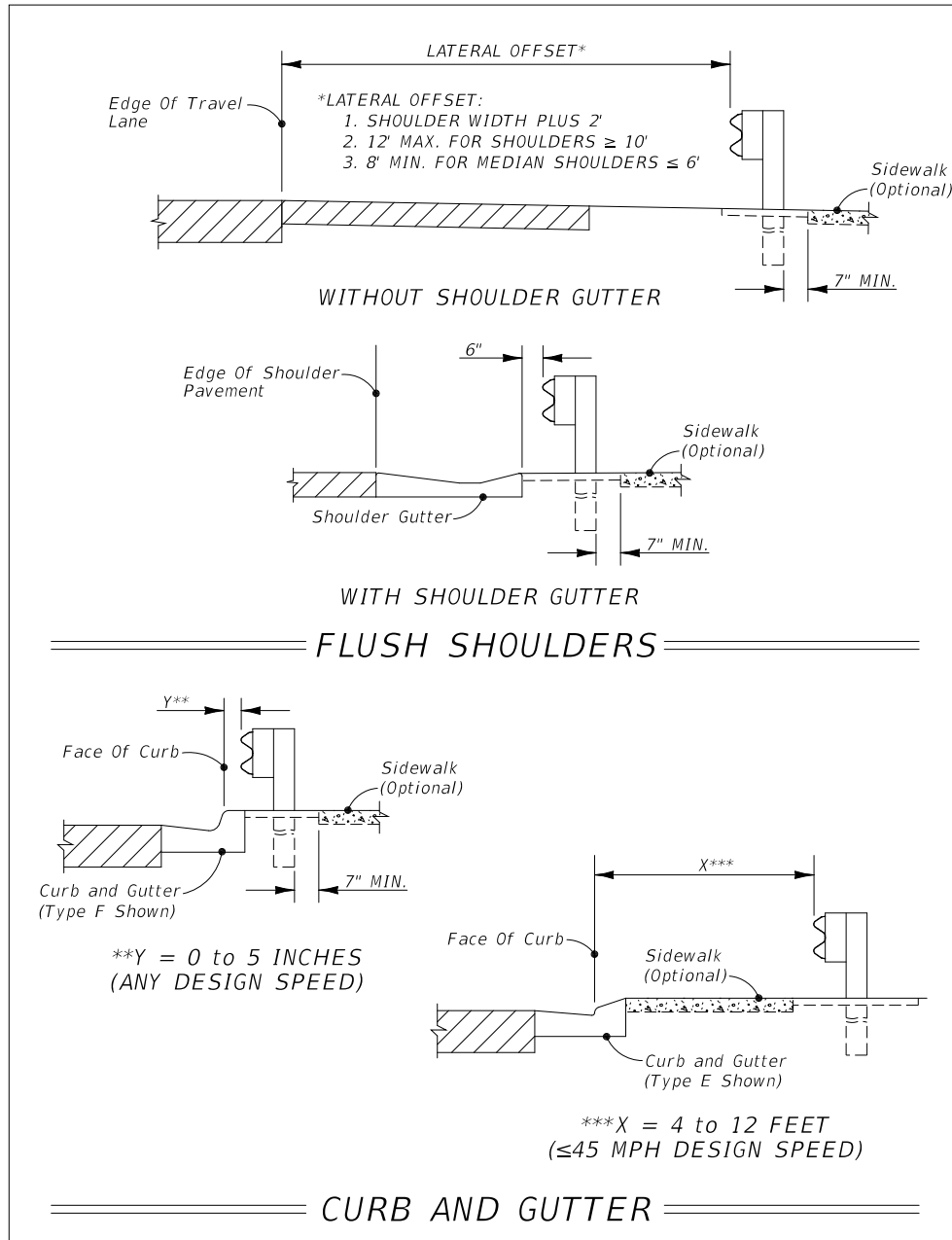
Longitudinal barriers shall be designed in accordance with specifications (including guide specifications) published by the American Association of State Highway and Transportation Officials (AASHTO). At a minimum, the **AASHTO Load and Resistance Factor Design (LRFD) Bridge Design Specifications, 6<sup>th</sup> Edition, (2012) with 2013 Interim Revisions** shall be used.

### D.2 Fencing, Pedestrian Channelization Devices or Landscaping

Fencing, pedestrian channelization devices or landscaping may be used to discourage pedestrian access to the roadway and aid in channeling pedestrian traffic to the proper crossing points. These should ~~Fencing or landscaping shall~~ not be considered a substitute for longitudinal barriers, but may be used in conjunction with redirection devices.

~~Fencing at the right of way line and placement of pedestrian (and bicycle) pathways in separate corridors outside of this line is necessary on limited access facilities.~~

**FIGURE 8-2 SIDEWALK WITH GUARDRAIL**

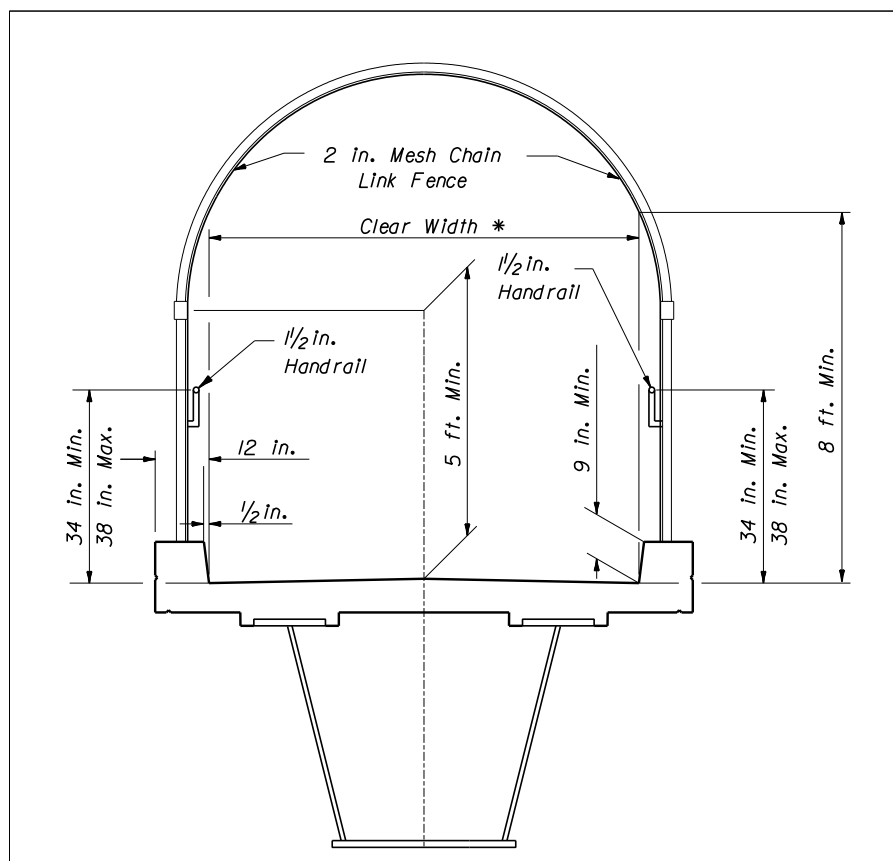


## E GRADE VERTICAL SEPARATION

Grade Vertical separation may be selectively utilized to support the crossing of large pedestrian volumes across highways where the traffic volume on the roadway is at or near capacity or where speeds are high. Overpasses or underpasses may be justified at major pedestrian generators such as schools, shopping centers, sports and amusement facilities, transit centers, commercial buildings, parks and playgrounds, hospitals, and parking facilities.

The minimum clear width of any stand-alone pedestrian overpass or underpass on a pedestrian accessible route is 8 feet. However, if the contiguous sidewalk or path is greater than 8 feet wide, the clear width of the overpass or underpass should match that width. The minimum clear height of a pedestrian overpass or underpass is 8 feet. See Figure 8.3 for an example of a bridge typical section.

**FIGURE 8.3 PEDESTRIAN BRIDGE TYPICAL SECTION**





## E.1 Overpasses

Pedestrian overpasses are typically bridge structures over major roadways or railroads. Overpasses should either provide elevator access or meet ADA ramp criteria for maximum slopes, level landings, and handrails on both sides. Bridges over roadways should be covered or screened to reduce the likelihood of objects being dropped or thrown below. The area adjacent to overpasses may be fenced to prevent unsafe crossings and to channel pedestrians to the overpass structure.

## E.2 Underpasses

Pedestrian underpasses or tunnels perform the same function as overpasses. Their use is convenient when the roadway is elevated above the surrounding terrain.

Underpasses should be adequately maintained to reduce potential problems in lighting, cleaning, policing, and flooding and to maximize safety. The area adjacent to underpasses may be fenced to prevent unsafe crossings and to channel pedestrians to the underpass structure.

The **FDOT Structures Manual - Volume 1 - Structures Design Guidelines (SDG), Section 10** provide additional guidance on engineered steel and concrete pedestrian bridges.

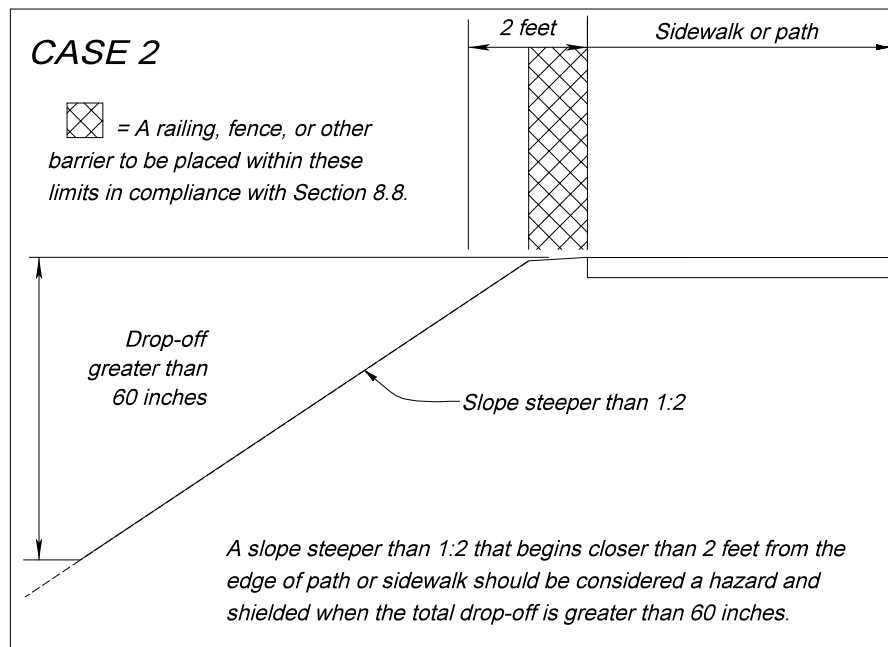
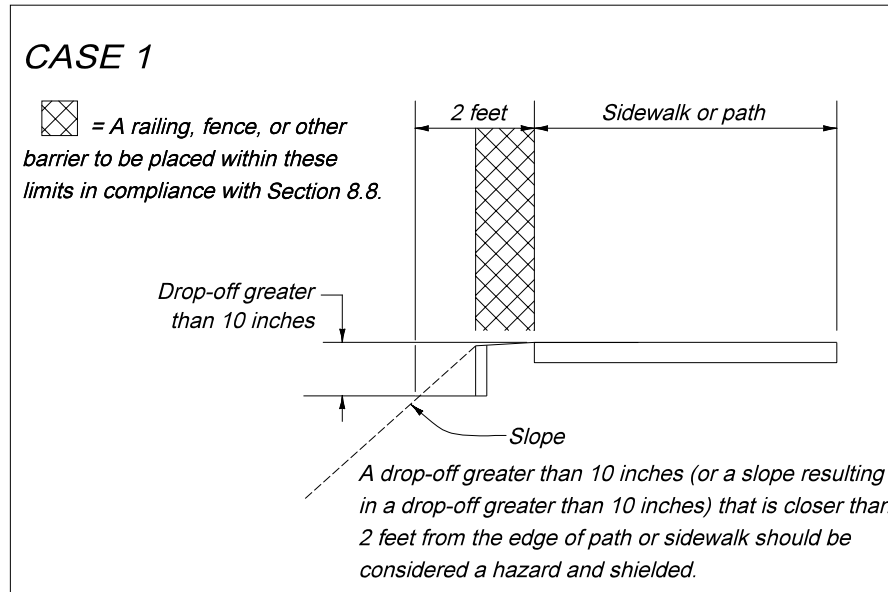
## **F DROP-OFF HAZARDS FOR PEDESTRIANS**

Drop-off hazards are defined as steep or abrupt downward slopes that can be perilous to pedestrians and bicyclists. Consider shielding any drop-off determined to be a hazard. Care should be taken when using Pedestrian/Bicycle Railings or fencing near intersections or driveways as they could obstruct the driver's line of sight. To reduce the need for railings as a sidewalk or shared use path approaches an intersection, consider extending cross drains and side drains to minimize drop-offs.

There are two cases that require shielding as shown in Figure 8.4. Depending on the depth of the drop-off and severity of the conditions below, shielding may be necessary for cases other than described above.

Railings or fences should be provided for vertical drop-off hazards or where shielding is required. The standard height for a pedestrian/bicycle railing is 42 inches. A 48 inch tall pedestrian/bicycle railing should be used when sidewalk grades are steeper than 5% and bicycle travel is expected. A standard railing is generally intended for urbanized areas, locations attaching to bridge rail or along concrete walkways. Fencing is generally intended for use in rural areas along paths and trails.

**FIGURE 8.4 DROP-OFF HAZARDS FOR PEDESTRIANS AND BICYCLES**



## **GF PEDESTRIAN CROSSINGS**

The design of pedestrian crossings and parallel pathways within the right of way shall be considered an integral part of the overall design of a street or highway.

The development of protection at any remaining crossings or conflict points must be adequate to achieve a total pedestrian transportation mode that is reasonably safe.

### **GF.1 Crosswalks**

~~Crosswalks serve as the pedestrian right-of-way across streets. A crosswalk is: (a) that part of a roadway at an intersection included within the connections of the lateral lines of the sidewalks on opposite sides of the highway, measured from the curbs or, in the absence of curbs, from the edges of the traversable roadway; (b) any portion of a roadway at an intersection or elsewhere distinctly indicated for pedestrian crossing by lines or other markings on the surface.~~

The design of pedestrian crosswalks should be based on the following requirements:

- Crosswalks should be placed at locations with ~~sufficient~~**ample** sight distances
- At crossings, the roadway should be free from changes in alignment or cross section
- The entire length of crosswalk shall be visible to drivers at a sufficient distance to allow a stopping maneuver
- Stop bars or yield markings, in conjunction with the appropriate signing, shall be provided at all marked crosswalks
- ~~All~~**C**rosswalks shall be easily identified and clearly delineated, in accordance with *Manual on Uniform Traffic Control Devices (MUTCD) (Rule 14-15.010)*

#### **GF.1.a Marked Crosswalks**

Marked crosswalks are one tool to allow pedestrians to cross the roadway safely. They are often used in combination with other treatments (signs, flashing beacons, curb extensions, pedestrian signals, raised median or refuge islands, and enhanced overhead lighting). Marked crosswalks serve

two purposes: 1) to inform motorists of the location of a pedestrian crossing so that they have time to lawfully yield to or stop for a crossing pedestrian; and 2) to assure the pedestrian that a legal crosswalk exists at a particular location. See Figure 8.5 for an example of a pedestrian median refuge with a curb extension.

### **FIGURE 8.5 PEDESTRIAN MEDIAN REFUGE WITH CURB EXTENSION**



Urban Street Design Guide, National Association of City Transportation Officials (NACTO)

Marked crosswalks on an uncontrolled leg of an intersection or a mid-block location shall be supplemented with other treatments (which may include beacons, curb extensions, raised medians, raised traffic islands, or enhanced overhead lighting) when any of the following conditions exist:

1. Where posted speeds are greater than 40 mph.
2. On a roadway with 4 or more lanes without a raised median or raised traffic island that has an ADT of 12,000 or greater.
3. On a roadway with 4 or more lanes with a raised median or raised traffic island that has or is projected to have (within 5 years) an ADT of 15,000 or greater.

See CHAPTER 6 – ROADWAY LIGHTING for information on illuminating crosswalks and pedestrian facilities.

Additional guidance on marked crosswalks can be found in the **AASHTO Guide for the Planning, Design, and Operation of Pedestrian Facilities** and **FHWA's Safety Effects of Marked vs. Unmarked Crosswalks at Uncontrolled Locations: Executive Summary and Recommended Guidelines.**

~~Marked crosswalks shall not be installed in an uncontrolled environment (without signals, stop signs, or yield signs) when the posted speeds are greater than 40 mph, or on multilane roads where traffic volumes exceed 12,000 vpd (without raised median) or 15,000 vpd (with raised median).~~

Marked crosswalks can also be used to create midblock crossings.

### **GF.1.b Midblock Crosswalks**

Midblock crosswalks facilitate crossings to places that people want to go but that are not well served by the existing sidewalk or path network. These pedestrian crossings commonly occur at schools, parks, museums, waterfronts, and other destinations. Designers should study both existing and projected pedestrian volumes in assessing warrants for midblock crossings to account for latent demand.

~~Midblock crossings help meet crossing needs within an area. At specific locations where intersections are spaced relatively far apart or substantial pedestrian generators are located between intersections, midblock crossing may be used; however, since midblock crossings are not generally expected by motorists, they should be well signed and marked. Midblock crossings are located according to a number of factors including pedestrian volume, traffic volume, roadway width, traffic speed and type, desired paths for pedestrians, land use, and to accommodate transit connectivity. Midblock crossings should not be installed where sight distance or sight lines are limited for either the motorist or pedestrian.~~

Midblock crossings should be ~~illuminated~~, marked, and signed ~~outfitted with advanced warning signs or warning flasher~~ in accordance with the **MUTCD**. See Figure 8.6 for an example of a midblock crosswalk.

### **FIGURE 8.6 RAISED MIDBLOCK CROSSWALK**



Suwannee Street, Tallahassee, Florida

Crosswalks may be supplemented with Hybrid Actuated Beacons (HAWKS) or Rectangular Rapid Flashing Beacons (RRFBs). Illumination should be evaluated if night-time pedestrian activity is expected. See Chapter 6 – Roadway Lighting for further information.

A HAWK is a special type of hybrid beacon used to warn and control traffic at an unsignalized location to assist pedestrians in crossing a street or highway at a marked crosswalk. **Chapter 4F. PEDESTRIAN HYBRID BEACONS, MUTCD** provides additional information regarding their installation. See Figure 8.7 for an example of a pedestrian hybrid beacon (HAWK).

[http://mutcd.fhwa.dot.gov/kno\\_2009r1r2.htm](http://mutcd.fhwa.dot.gov/kno_2009r1r2.htm)



### **FIGURE 8.7 PEDESTRIAN HYBRID BEACON**



16<sup>th</sup> Street South, St. Petersburg, Florida

The RRFB uses rectangular-shaped high-intensity LED-based indications, flashes rapidly in a wig-wag "flickering" flash pattern, and is mounted immediately between the crossing sign and the sign's supplemental arrow plaque. Use of RRFBs should be limited to locations with the most critical safety concerns, such as pedestrian and school crosswalks across uncontrolled approaches. The **MUTCD** provides further information on obtaining **interim approval** for the use of RRFBs. See Figure 8.8 for an example of a rectangular rapid flashing beacon (RRFB).

[http://mutcd.fhwa.dot.gov/res-interim\\_approvals.htm](http://mutcd.fhwa.dot.gov/res-interim_approvals.htm)

### **FIGURE 8.8 PEDESTRIAN MEDIAN REFUGE WITH RECTANGULAR RAPID FLASHING BEACONS**



4th Street North, St. Petersburg, Florida

#### **F.1.c — Crossing Distance Considerations**

At midblock locations where roadway crossings exceed sixty feet, or where there are a limited number of gaps in traffic, a median or crossing island should be considered and be accessible. When a midblock crossing is provided along a multilane arterial, a median or crossing island is desirable, and consideration should be given to providing supplementary traffic control devices (signs, beacons, signals, etc.).

#### **GF.2 Curb Ramps**

Curb ramps provide access between the sidewalk and the street for people who use mobility aids such as wheelchairs and scooters, people pushing strollers and pulling suitcases, people children on bicycles, and delivery services. Curb ramps and at grade connections from the sidewalk to the roadway shall include, with detectable warnings, meeting the requirements of Curb ramps 2006 ADA Standards for Transportation Facilities Accessible Design and the 2012 Florida Accessibility Building Code (Rule 9B-7.0042), Chapter 11, shall be provided at all pedestrian crossings, including mid-block mid-block crossings and intersections to give persons with disabilities safe access. A level landing is necessary for turning, maneuvering, or bypassing the sloped surface. The 2006 Americans with

Disabilities Act – Standards for Transportation Facilities and the 2012 Florida Accessibility Code impose additional requirements for the design and construction of curb ramps and pedestrian facilities.

### **GF.3 Controls**

Signs, signals, and markings should be utilized to provide the necessary information and direction for pedestrians. All directions and regulations should be clear, consistent and logical, and should, at a minimum, conform to the requirements given in the MUTCD. The use of accessible pedestrian signals that include audible and/or vibro-tactile, and visual signals should be considered for pedestrian traffic control and regulation.

### **GF.4 Sight Distance**

The general requirements for sight distances for the driver are given in CHAPTER 3 - GEOMETRIC DESIGN.

Stopping sight distances greater than the minimum should be provided at all pedestrian crossings. These sight distances should include a clear view of the pedestrian approach pathway for at least 15 feet from the outside travel lane. Where parallel pedestrian pathways are within the roadside recovery area, or where casual pedestrian crossings are likely, the normal required stopping sight distance should also include a clear view of the entire roadside recovery area.

Sight distances shall be based upon a driver's eye and object height as discussed in CHAPTER 3 – GEOMETRIC DESIGN. Due to the small size of some pedestrians (particularly children), they are generally easy to confuse with other background objects.

Parking shall be prohibited where it would interfere with the required sight distance. Particular care should be exercised to ensure ample mutual sight distances are provided at all intersections and driveways.

### **G.5 Railroad Crossings**

Light rail, surface commuter rail, conventional passenger rail, and freight railroads may cross roadways, sidewalks and shared use paths at grade. Special design

considerations are needed for these pedestrian intersections so that pedestrians are warned of the crossing and potential presence of a train. In addition, these crossings have specific accessibility requirements relating to surface continuity which must be met. See Chapter 7 – Rail Highway Grade Crossings for further information.

## **HF.5 LIGHTING**

Lighting of the roadway itself is not only important for the safety of vehicular traffic, but also valuable for the protection of pedestrians. Vehicle headlamps often do not provide sufficient lighting to achieve the required stopping sight distance. Since this requirement is of vital importance at any potential pedestrian crossing point, lighting of the crossing should be considered. Lighting a street or highway is also valuable in improving the pedestrian's view of oncoming vehicles. At intersections or other locations with vehicle turning maneuvers, vehicle headlights may not be readily visible to the pedestrian.

Lighting shall be provided in pedestrian underpasses and should be considered on pedestrian overpasses. All pedestrian lighting shall be vandal resistant. The installation of daytime lighting is warranted when underpass user visibility requirements are not met with sunlight. Pedestrian underpass and overpass lighting should conform to the general lighting requirements given in the American Association of State Highway and Transportation Officials (AASHTO) Roadway Lighting Design Guide.

The general requirements for lighting on streets and highways are given in CHAPTER 6 - ROADWAY LIGHTING. Pathways adjacent to a street or highway should not be illuminated to a level more than twice that of the roadway itself.

In general, lighting should be considered as warranted when it is necessary, at night, to provide the mutual sight distance capabilities described in the preceding CHAPTER 3 - GEOMETRIC DESIGN. Locations with significant night time pedestrian traffic that should be considered for lighting of the roadway and adjacent pedestrian facilities include the following:

- Any street or highway that meets the warranting criteria given in CHAPTER 6 - ROADWAY LIGHTING
- Streets and highways with speed limits in excess of 40 mph that do not have adequate pedestrian conflict elimination

- Sections of highway with minimal separation of parallel pedestrian pathways
- Intersections, access and decision points, and areas adjacent to changes in alignment or cross sections
- Areas adjacent to pedestrian generators
- Bus stops and other mass transit transfer locations
- Parking facilities
- Entertainment districts, sports/recreation complexes, schools, and other activity centers generating night travel
- Pedestrian crossings
- Any location where improvement of night time sight distance will reduce the hazard of vehicle-pedestrian conflicts

See Chapter 6 – Roadway Lighting for further information on lighting of pedestrian facilities and shared use paths.

## **IG REFERENCES FOR INFORMATIONAL PURPOSES**

1. Florida Department of Transportation Transit Facility Design  
<http://www.dot.state.fl.us/transit/Pages/NewTransitFacilitiesDesign.shtm>
2. USDOT/FHWA ADA Standards for Accessible Design (ADAAG)  
<http://www.access-board.gov/ada-aba/ada-standards-dot.cfm>  
<http://www.access-board.gov/guidelines-and-standards/buildings-and-sites/about-the-ada-standards/ada-standards>
3. AASHTO – Guide for the Planning, Design, and Operation of Pedestrian Facilities  
<https://bookstore.transportation.org/>
4. AASHTO – Roadway Lighting Design Guide  
<https://bookstore.transportation.org/>
5. NACTO Urban Streets Design Guide  
<http://nacto.org/usdg>
6. Designing Walkable Urban Thoroughfares (CNU and ITE)  
<http://www.cnu.org/streets>

7. Project Management Handbook (CSS)  
<http://www.dot.state.fl.us/projectmanagementoffice/Publications/default.shtm>
8. FHWA Policy Memo for Flexibility in Pedestrian and Bicycle Facility Design  
[http://www.fhwa.dot.gov/environment/bicycle\\_pedestrian/guidance/design\\_guidance/design\\_flexibility.cfm](http://www.fhwa.dot.gov/environment/bicycle_pedestrian/guidance/design_guidance/design_flexibility.cfm)
- 4-9. AASHTO Load and Resistance Factor Design (LRFD) Bridge Design Specifications, 6<sup>h</sup> Edition, (2012) with 2013 Interim Revisions  
<https://bookstore.transportation.org/Home.aspx>

## CHAPTER 9

### BICYCLE FACILITIES

<u>A</u>	<u>Introduction.....</u>	<u>9-1</u>
<u>B</u>	<u>On-Street Facilities.....</u>	<u>9-1</u>
	<u>B.1 Bicycle Lanes.....</u>	<u>9-2</u>
	<u>B.2 Buffered Bicycle Lanes.....</u>	<u>9-20</u>
	<u>B.3 Bicycle Lane with Bus Bay.....</u>	<u>9-23</u>
	<u>B.4 Green Colored Bicycle Lanes.....</u>	<u>9-24</u>
	<u>B.5 Paved Shoulders.....</u>	<u>9-30</u>
	<u>B.6 Wide Outside Lanes.....</u>	<u>9-30</u>
	<u>B.7 Shared Lane Markings.....</u>	<u>9-31</u>
	<u>B.8 Bicycles May Use Full Lane Sign.....</u>	<u>9-38</u>
<u>C</u>	<u>Shared Use Paths.....</u>	<u>9-38</u>
	<u>C.1 Width and Clearance.....</u>	<u>9-38</u>
	<u>C.2 Separation Between Shared Use Paths and Roadways.....</u>	<u>9-40</u>
	<u>C.3 Design Speed.....</u>	<u>9-43</u>
	<u>C.4 Horizontal Alignment.....</u>	<u>9-43</u>
	<u>C.5 Accessibility.....</u>	<u>9-44</u>
	<u>C.6 Structures.....</u>	<u>9-44</u>
	<u>C.7 Pavement Markings and Signage.....</u>	<u>9-45</u>
<u>D</u>	<u>Railroad Crossings.....</u>	<u>9-47</u>
<u>E</u>	<u>Structures.....</u>	<u>9-47</u>
<u>I</u>	<u>REFERENCES FOR INFORMATIONAL PURPOSES.....</u>	<u>9-59</u>
<del>A</del>	<del>Introduction.....</del>	<del>9-1</del>
<del>B</del>	<del>On-Street Facilities.....</del>	<del>9-1</del>
	<del>B.1 Bicycle Lanes.....</del>	<del>9-2</del>
	<del>B.2 Paved Shoulders.....</del>	<del>9-6</del>
	<del>B.3 Wide Outside Lanes.....</del>	<del>9-6</del>

B.4	Shared Lane Markings	9-6
C	Shared Use Paths	9-10
C.1	Separation between Shared Use Paths and Roadways	9-10
C.2	Width	9-12
C.3	Horizontal Clearance	9-12
C.4	Vertical Clearance	9-13
C.5	Design Speed	9-13
C.6	Structures	9-13
C.7	Ramp Widths	9-13
D	Railroad Crossings	9-13
E	Structures	9-14



## FIGURES

Figure 9-1	Minimum Widths for Bicycle Lanes .....	<b>Error! Bookmark not defined.</b>
Figure 9-2	Detail of Bicycle Lane Markings .....	<b>Error! Bookmark not defined.</b>
Figure 9-3	Shared Lane Marking .....	9-32
Figure 9-4	Shared Lane Marking Placement (With On-Street Parking) .....	9-34
Figure 9-5	Shared Lane Marking Placement (No Designated Parking) .....	<b>Error! Bookmark not defined.</b>
Figure 9-6	Bicycle Lanes with Separate Right Turn Lane, Curb and Gutter Typical Section .....	<b>Error! Bookmark not defined.</b>
Figure 9-7	Bicycle Lanes with Bus Bay, No Right Turn Lane, Curb and Gutter Typical Section .....	9-49
Figure 9-8	Bicycle Lanes with On Street Parking, No Right Turn Lane, Curb and Gutter Typical Section .....	9-50
Figure 9-9	Bicycle Lanes with Separate Right Turn Lane, Flush Shoulder Typical Section .....	9-51
Figure 9-10	Bicycle Lanes with No Right Turn Lane, Flush Shoulder Typical Section .....	9-53
Figure 9-11	Bicycle Lane with Right Turn Drop Lane, Curb and Gutter Typical Section .....	9-54
Figure 9-12	"Tee" Intersection with Bicycle Lane, Separate Right and Left Turn Lanes, Curb and Gutter Typical Section .....	9-55
Figure 9-13	"Tee" Intersection with Bicycle Lanes, Left Turn Lane and Right Turn Drop Lane, Curb and Gutter Typical Section .....	9-57
Figure 9-14	Bicycle Lanes on Interchange Ramps, Flush Shoulder Typical Section .....	9-58

## CHAPTER 9

### BICYCLE FACILITIES

#### A Introduction

Bicycle facilities should be given full consideration in the planning and development of transportation facilities, including the incorporation of such facilities into state, regional, and local transportation plans and programs under the assumption that transportation facilities will be used by cyclists. Bicycle facilities should be established in conjunction with the construction, reconstruction, or other change of any transportation facility and special emphasis should be given to projects in or within 1 mile of an urban area. The provision for bicycle facilities is also desirable for resurfacing, restoration & rehabilitation (RRR) projects.

Bicycle and pedestrian facilities are not required to be established:

1. Where their establishment would be contrary to public safety;
2. When the cost would be excessively disproportionate to the need or probable use;  
~~and~~
3. Where other available means or factors indicate an absence of need.

Appropriately designed and located bicycle facilities play an important role in supporting bicycle travel. Bicyclists should be considered in all phases of transportation planning, design, construction and maintenance activities. Particular emphasis should be given to new construction, reconstruction, intersection improvement, and transit projects.- Bicycle facilities can include bicycle lanes, paved shoulders, wide curb lanes, shared lanes, shared use paths, and bicycle parking facilities.

#### B On-Street Facilities

Provisions for bicycle traffic should be incorporated in the original roadway design. All roadways, except where bicycle use is prohibited by law, should be designed, constructed and maintained under the assumption they will be used by bicyclists. Roadway conditions should be favorable for bicycling, with smooth pavement and limited changes in elevation along edge lines. Drainage inlets and utility covers that cannot be moved out of the travel way should be designed flush with grade, well seated, and make use of bicycle-compatible grates and covers.

Railroad grade crossings on a diagonal can cause steering difficulties for bicyclists. Crossings for bicycle facilities should be perpendicular to the rail. This can be accomplished with a widened shoulder or bicycle lane, or separate path. Consideration should be given to improving the smoothness of the crossing and reducing the width and depth of the flangeway opening. Flangeway fillers can be used on heavy rail lines to minimize the size of the opening adjacent to the rail.

~~In addition, B~~bicycle lanes, paved shoulders, wide curb lanes, or shared lanes should be included to the fullest extent feasible. The appropriate selection of a bicycle facility depends on many factors, including motor vehicle and bicycle traffic characteristics, adjacent land use and expected growth patterns. All new or reconstructed arterial and collector roadways, in and within one mile of an urban area, should include bicycle lanes.

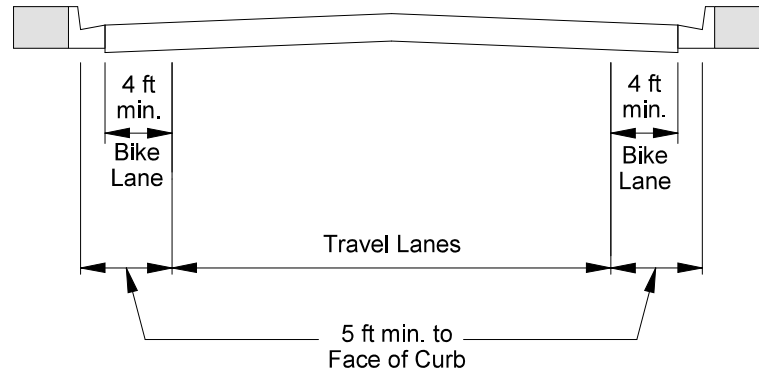
Rumble strips used in a traffic lane to alert operators to conditions ahead (e.g. stop signs, traffic signals or curves) should provide clear space (free of rumble strips) for bicyclists. This clear space may be a paved shoulder or if no paved shoulder is present, a minimum of 1.5 feet of clear space at the outermost portion of the lane.

## B.1 Bicycle Lanes

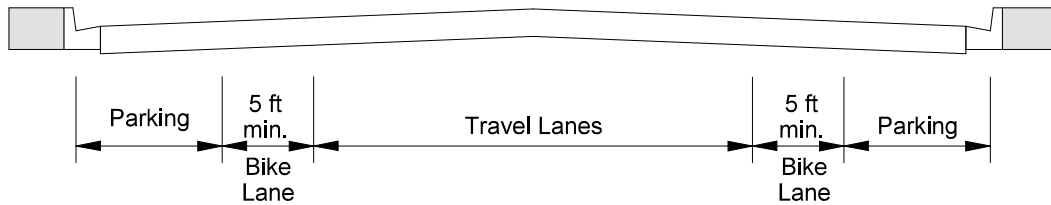
Bicycle lanes delineate available roadway space for preferential use by bicyclists; providing more predictable movements by motorists and bicyclists. Bicycle lanes also help increase the total capacity of highways carrying mixed bicycle and motor vehicle traffic. Bicycle lanes shall have a minimum functional width of 4 feet. At least 1 foot additional width is needed when the bicycle lane is adjacent to a curb or other barrier, on-street parking is present, there is substantial truck traffic (>10%), or posted speeds exceed 50 mph. Minimum bBicycle lane widths are illustrated in [Figure 9-1](#). The 4-foot bicycle lane shown in the flush shoulder typical section assumes the grass portion of the shoulder provides emergency maneuvering room.

**Figure 9-1 Minimum Widths for Bicycle Lanes**

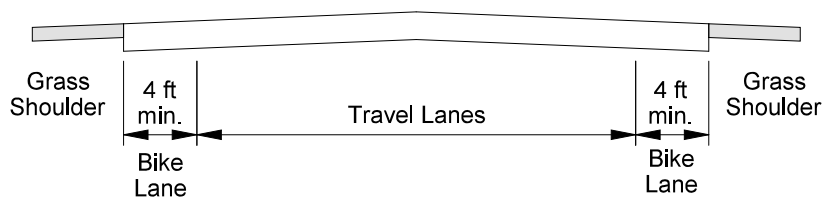
**a) Curbed Street without Parking**



**b) Curbed Street with Parking**



**c) Roadway without Curb and Gutter**

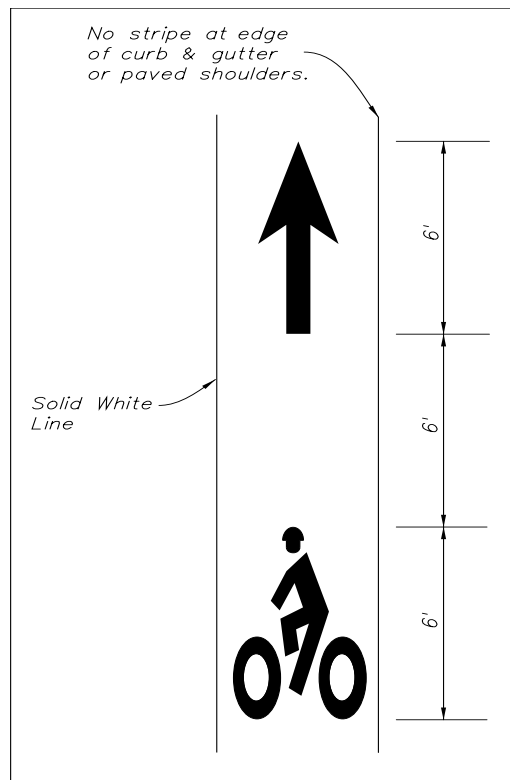


Bicycle lanes are one-way facilities and carry bicycle traffic in the same direction as the adjacent motor vehicle traffic. A bicycle lane should be delineated from the travel lanes with a solid white line and be marked with the bicycle symbol and arrow as shown in Figure 9-2. The dimensions for each pavement marking is 72" long, separated by 72". ~~Bicycle lane markings should be placed immediately after major intersections and driveways, with a maximum spacing of 600 feet in urban areas and 1,320 feet in rural areas.~~

The recommended placement of bicycle lane markings is:

- a) At the beginning of a bicycle lane, on the far side of major intersections, and prior to and within the bicycle lane between a through lane and turn lane.
- b) Along the roadway as needed to provide a maximum spacing of 1,320 for posted speeds less than or equal to 45 mph, 2,640 feet for a posted speed of 50 mph or greater.

Figure 9-2 Detail of Bicycle Lane Markings [KM1]



If used, bike lane signs and plaques should be placed in advance of the upstream end of the bicycle lane, at the downstream end of the bicycle lane, and at periodic intervals based upon prevailing speed of bicycle and other traffic, block length, and distances from adjacent intersections, and other considerations. They should only be used in conjunction with marked bicycle lanes. Bike lane signs are not required.

**Figure 9–3 Bicycle Lanes**



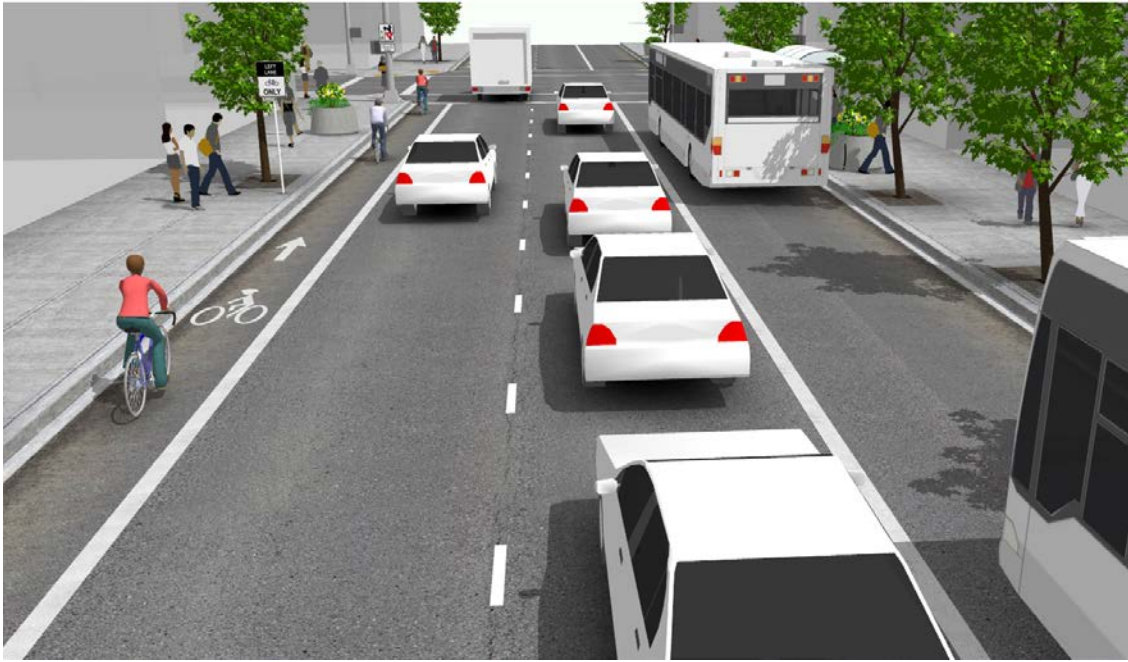
NACTO Urban Bikeway Design Guide, National Association of City Transportation Officials

A through bicycle lane shall not be positioned to the right of a right turn only lane or to the left of a left turn only lane. For new construction, reconstruction, and traffic operations projects, where bicycle lanes are provided between the through lane and right turn lane, bus bay or parking lane they shall be a minimum of 5 feet wide. For bicycle lanes adjacent to parking lanes, if the parking volume is substantial or the turnover is high a width of 6-7 feet is desirable to avoid opening vehicle doors. ~~n additional 1-2 feet of width should be provided for the bicycle lane where right of way is adequate.~~

On one-way streets, bicycle lanes should generally be placed on the right side of the street. A bicycle lane on the left side of the street can be considered when a bicycle lane on the left will substantially decrease the number of conflicts, such as

those caused by frequent bus traffic, heavy right turning movements, high-turnover parking lanes, or if there are a significant number of left turning bicyclists. See Figure 9.4 for an illustration of left side bicycle lanes.

**Figure 9-4 Left Side Bicycle Lanes**



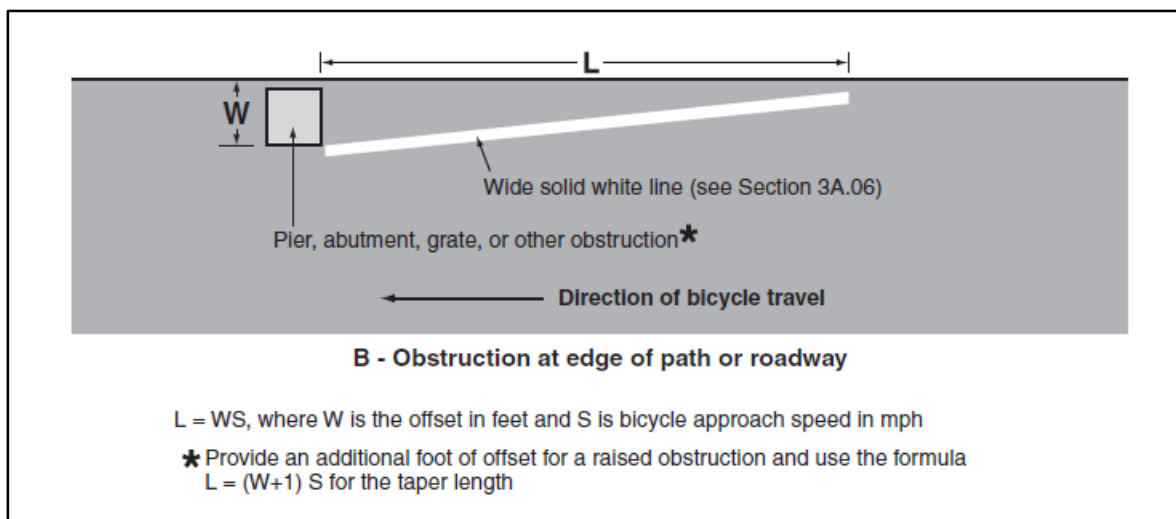
NACTO Urban Bikeway Design Guide, National Association of City Transportation Officials

Bicycle lanes shall not be provided on the circular roadway of a roundabout, and shall be transitioned prior to the roundabout in accordance with the MUTCD.

Existing drainage inlets, grates and utility covers shall be evaluated as to whether they present an obstruction to bicyclists, and should be relocated out of the cyclist's path of travel. Drainage inlets, grates and utility covers to remain should be adjusted to be flush with the adjacent pavement surface, utilize a grate recommended for bicycle travel, and may be marked as an obstruction.

Advance warning of an inlet or other obstruction may be provided as shown in the MUTCD, Part 9. Additional information on appropriate drainage inlets in or near bicycle facilities can be found in the *Florida Dept. of Transportation's Storm Drain Handbook, Figures 3-11 and 3-12, October 2014 Edition.* (will move to FDOT's Drainage Manual in 2015 and reference will be updated)

**Figure 9-5 Example of Obstruction Pavement Markings**



Bicycle lanes should provide bicycle-compatible drainage inlet grates, smooth pavement surfaces, and traffic signals should be responsive to bicyclists. Regular maintenance of bicycle lanes should be a top priority, since bicyclists are unable to use a lane with potholes, debris or broken glass.

In conjunction with resurfacing projects, the roadway width shall be redistributed when practical to provide for bicycle facilities. The types of bicycle facilities considered for implementation include buffered bicycle lanes, bicycle lanes, wide



outside lanes, and shared lanes. Lane widths on urban multilane roadways and two-lane curb and gutter roadways may be reduced as shown in Table 9.1 to provide for bicycle facilities.

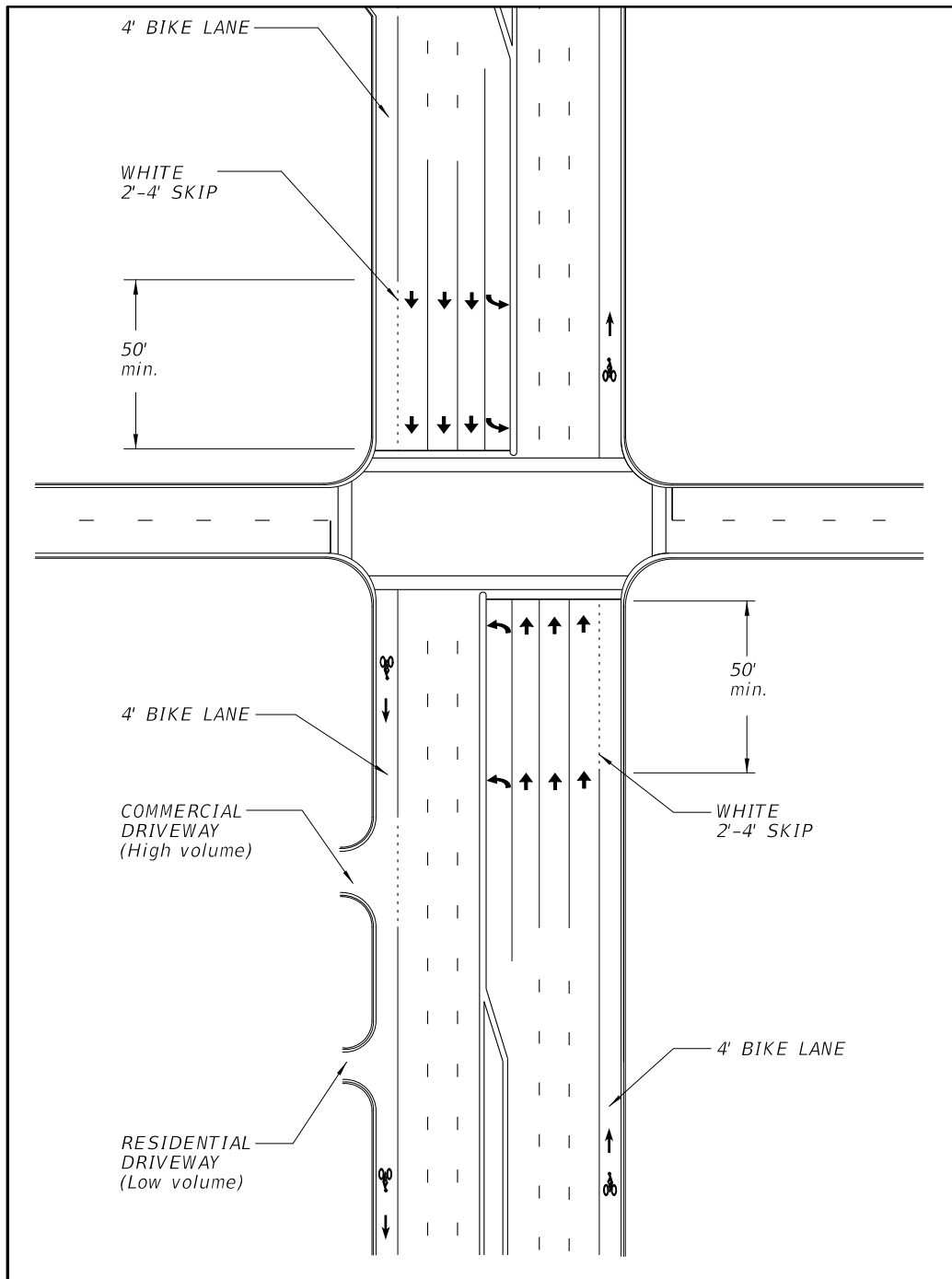
**Table 9.1 Lane Widths  
 Urban Multilane or Two-Lane with Curb and Gutter**

<u>Design Year AADT</u>	<u>Design Speed (mph)</u>	<u>Minimum Thru Lane ( ft. )</u>	<u>Minimum Turn Lane ( ft. )</u>	<u>Minimum Parking Lane ( ft. )</u>
<u>ALL</u>	<u>ALL</u>	<u>10<sub>1</sub></u>	<u>9<sub>2</sub></u>	<u>7<sub>3</sub></u>

1. 11 ft. where either of the following conditions exist:
  - a) Trucks are >10% of Design Year Traffic.
  - b) Design Speed is 40 mph or greater.
2. 10 ft. for 2 Way Left Turn Lanes.
3. A minimum width of 7 ft. measured from face of curb may be left in place. Otherwise provide 8 ft. minimum, measured from face of curb.

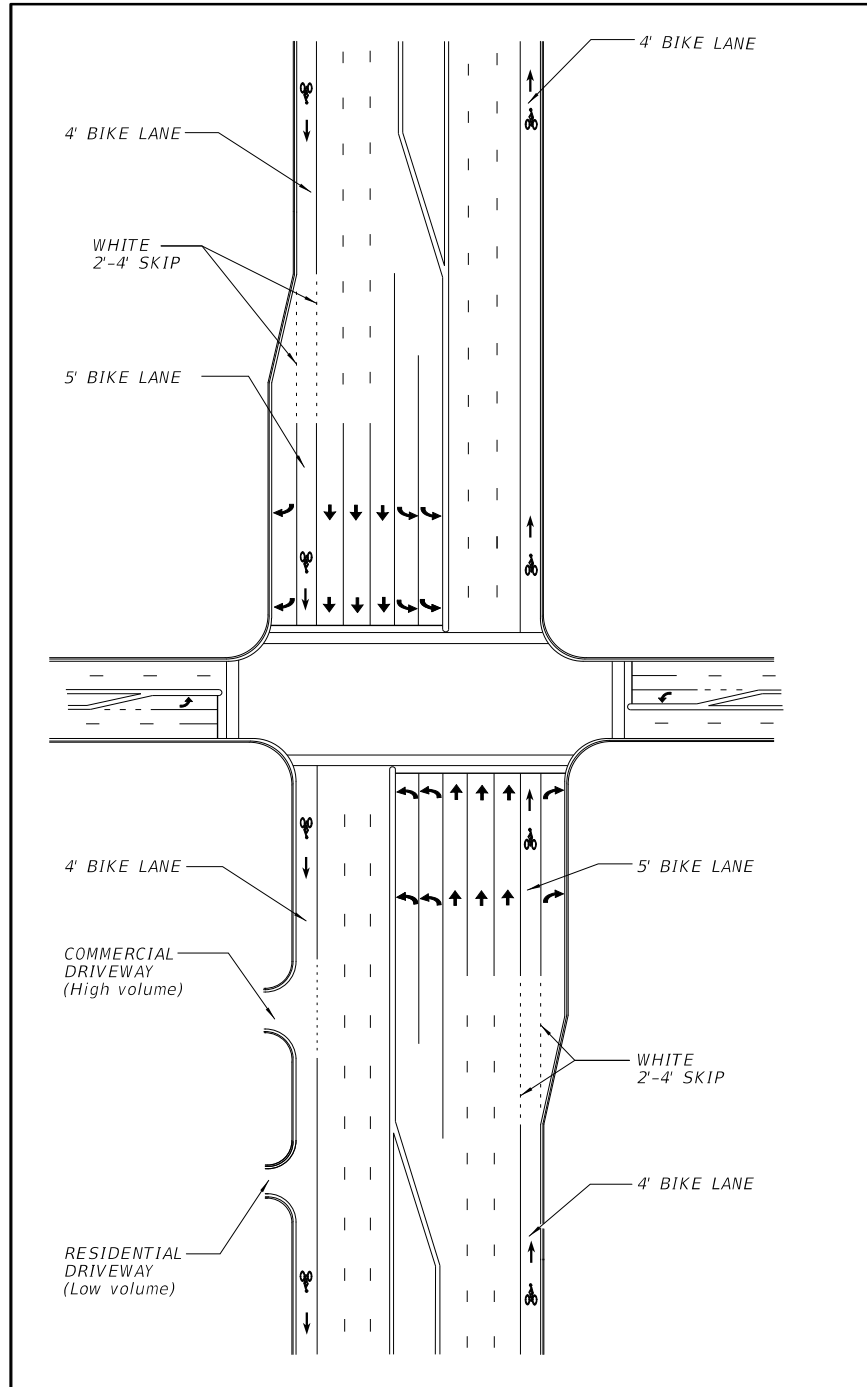
~~The combined minimum width of a travel lane and a bicycle lane is 14 feet. Bicycle lanes shall not be provided on the circular roadway of a roundabout, and shall be transitioned prior to the roundabout in accordance with the MUTCD. Various configurations of bicycle lanes on curb and gutter and flush shoulder typical sections are illustrated in Figure 9-~~xx~~6 – 9-~~xx~~14.~~

**Figure 9-x Bicycle Lane Markings** [KM2]

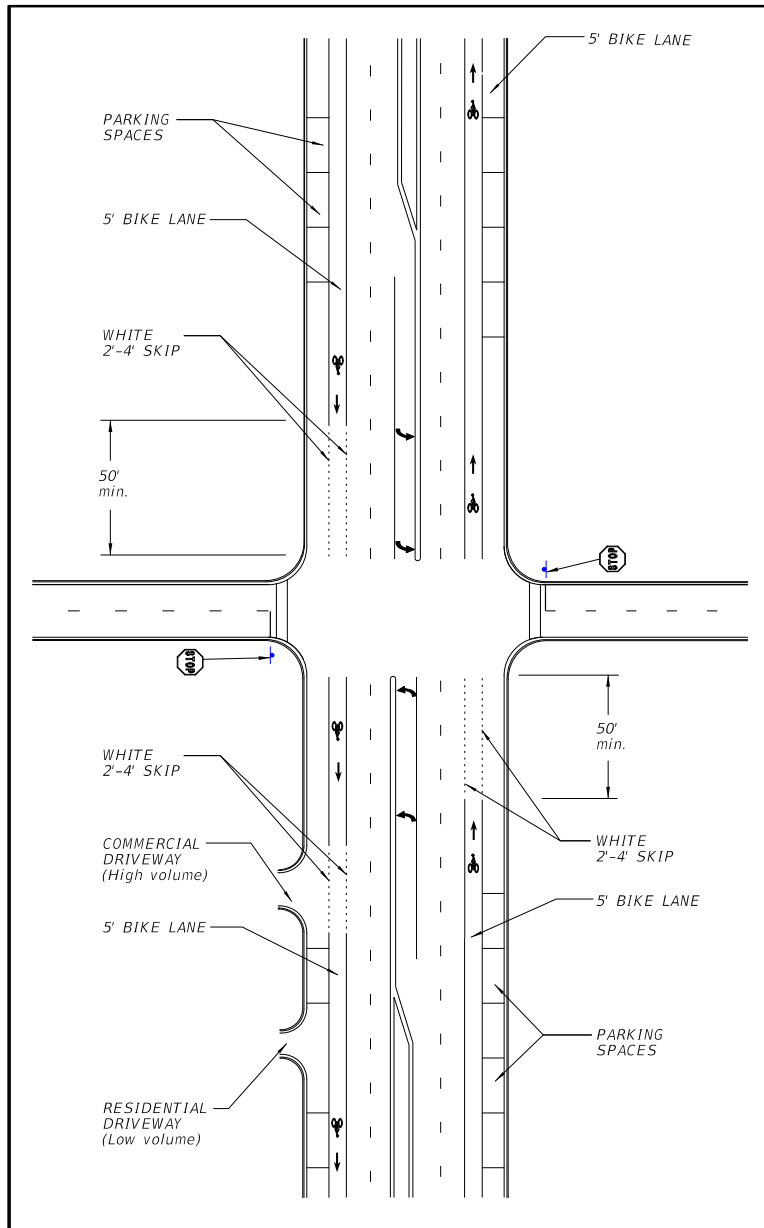


**Revise to residential and low volume commercial!!**

**Figure 9-x6 Bicycle Lanes with Separate Right Turn Lane  
(Curb and Gutter Typical Section)**

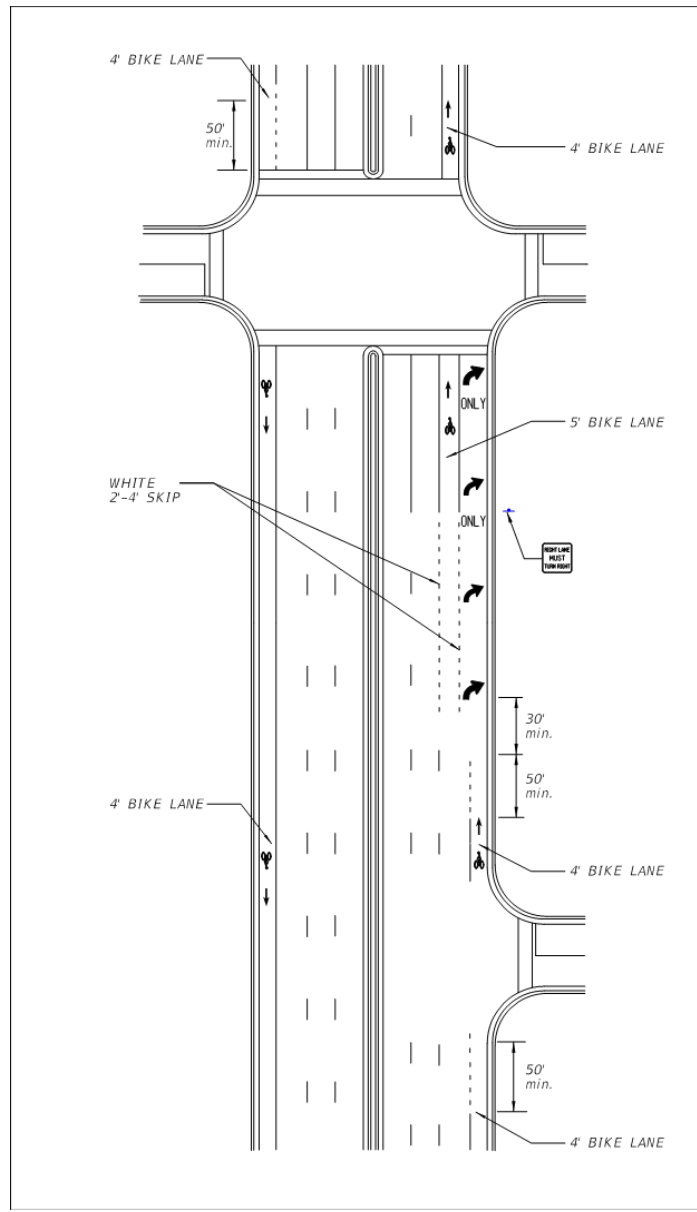


**Figure 9-x Bicycle Lanes with On Street Parking, No Right Turn Lane  
(Curb and Gutter)**

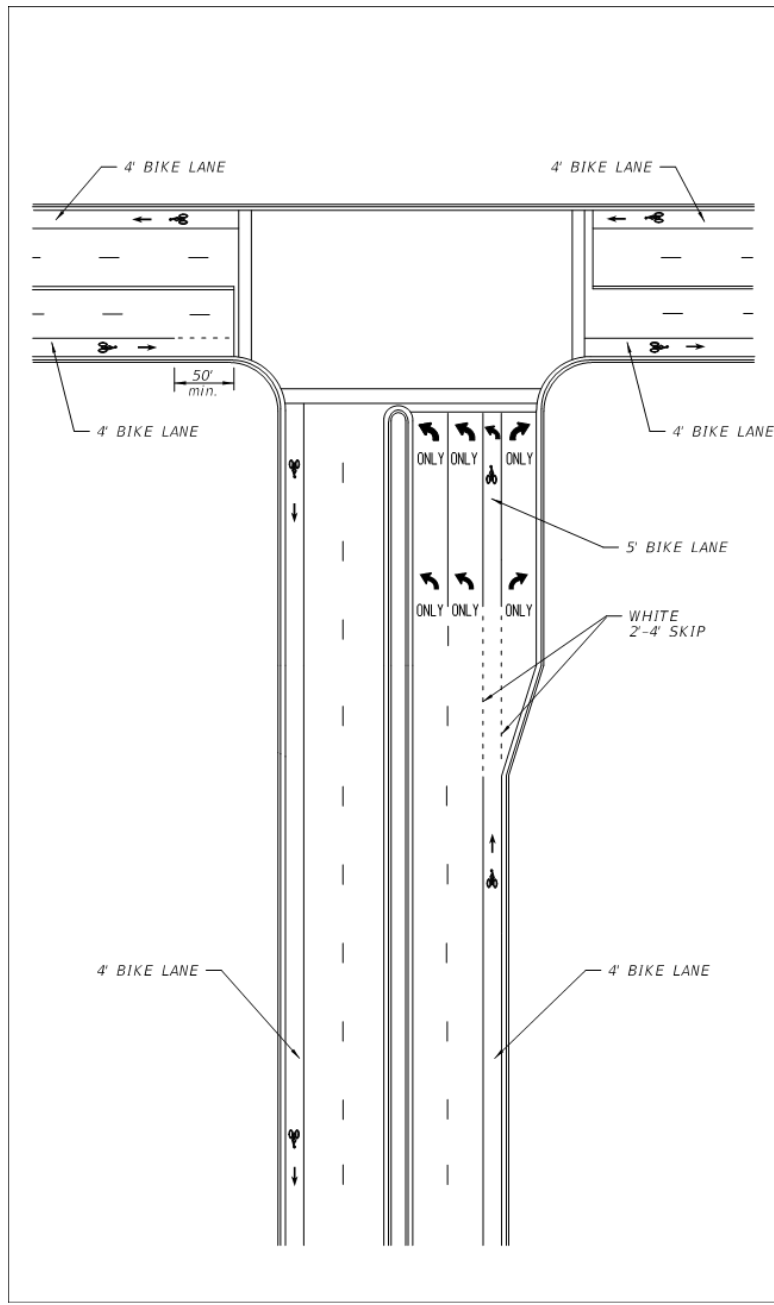


**High volumes (x cars per hour)**

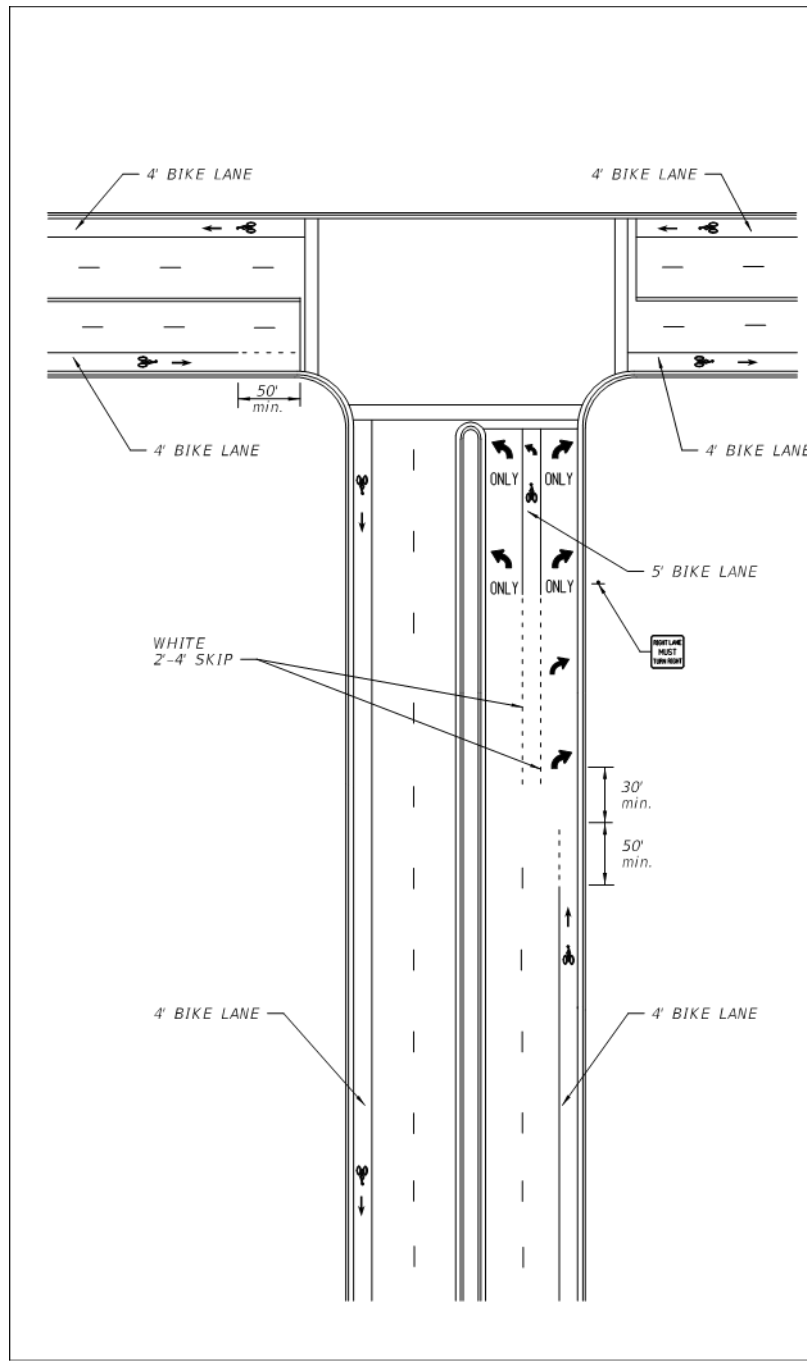
**Figure 9-x Bicycle Lane with Right Turn Drop Lane, Curb and Gutter**  
**Typical Section**



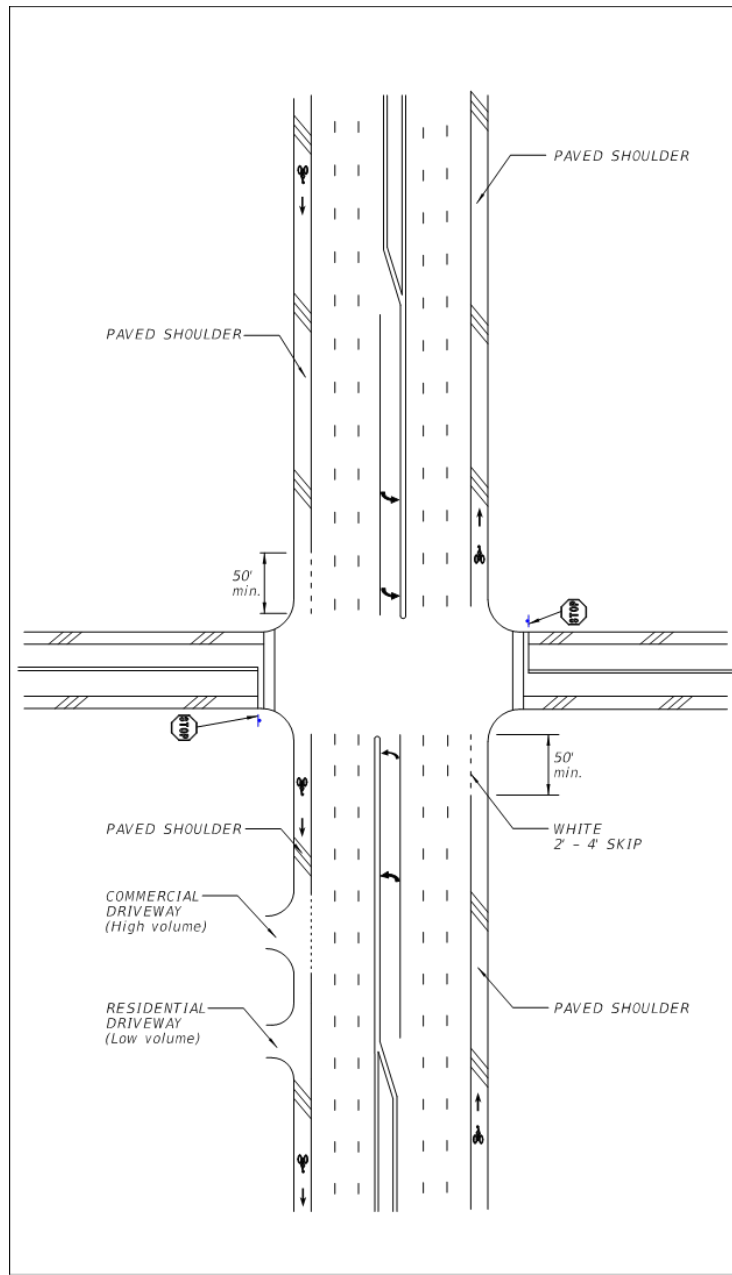
**Figure 9-x "Tee" Intersection with Bicycle Lane, Separate Right and Left Turn Lanes, Curb and Gutter Typical Section**



**Figure 9-x "Tee" Intersection with Bicycle Lanes, Left Turn Lane and Right Turn Drop Lane, Curb and Gutter Typical Section**

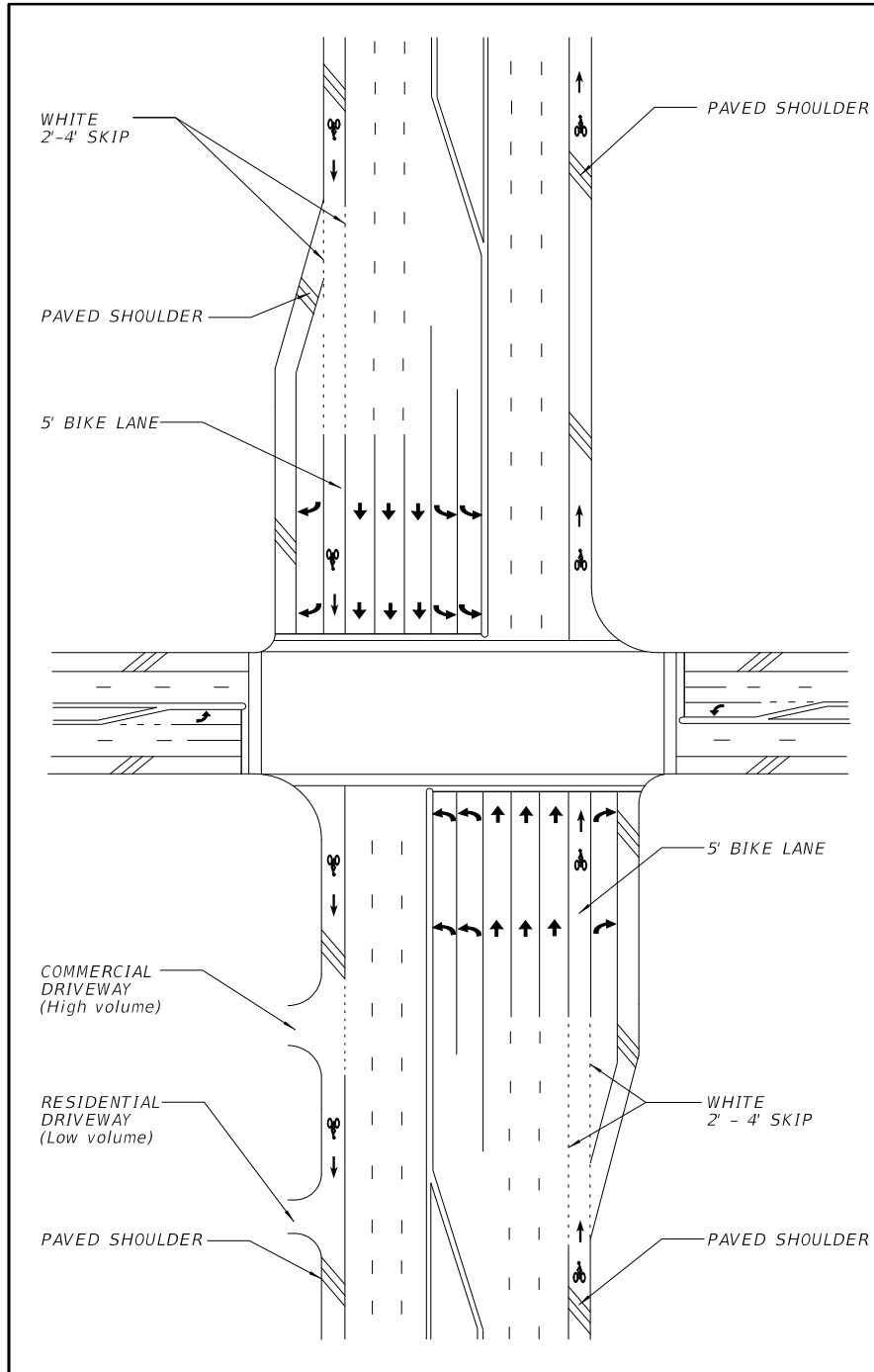


**Figure 9-x Bicycle Lanes with No Right Turn Lane, Flush Shoulder  
Typical Section**

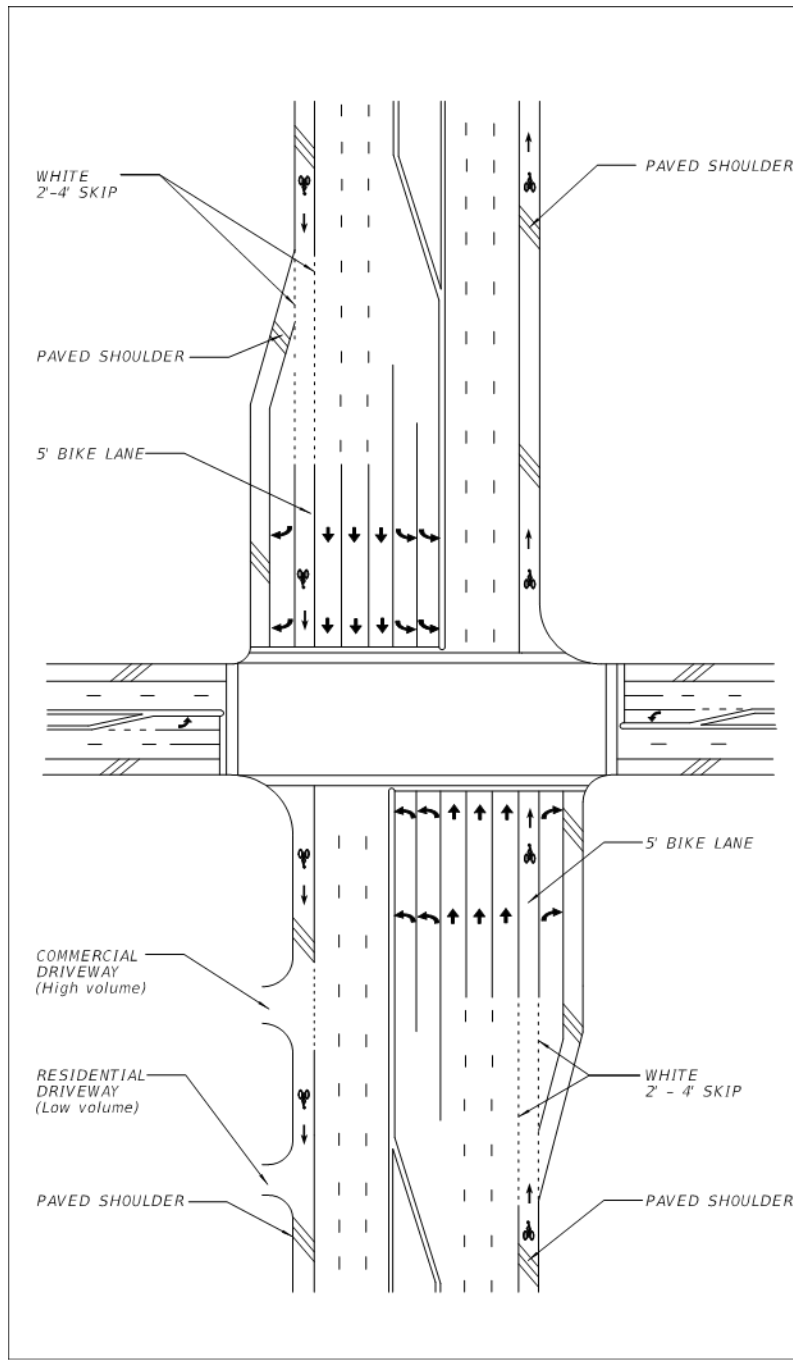




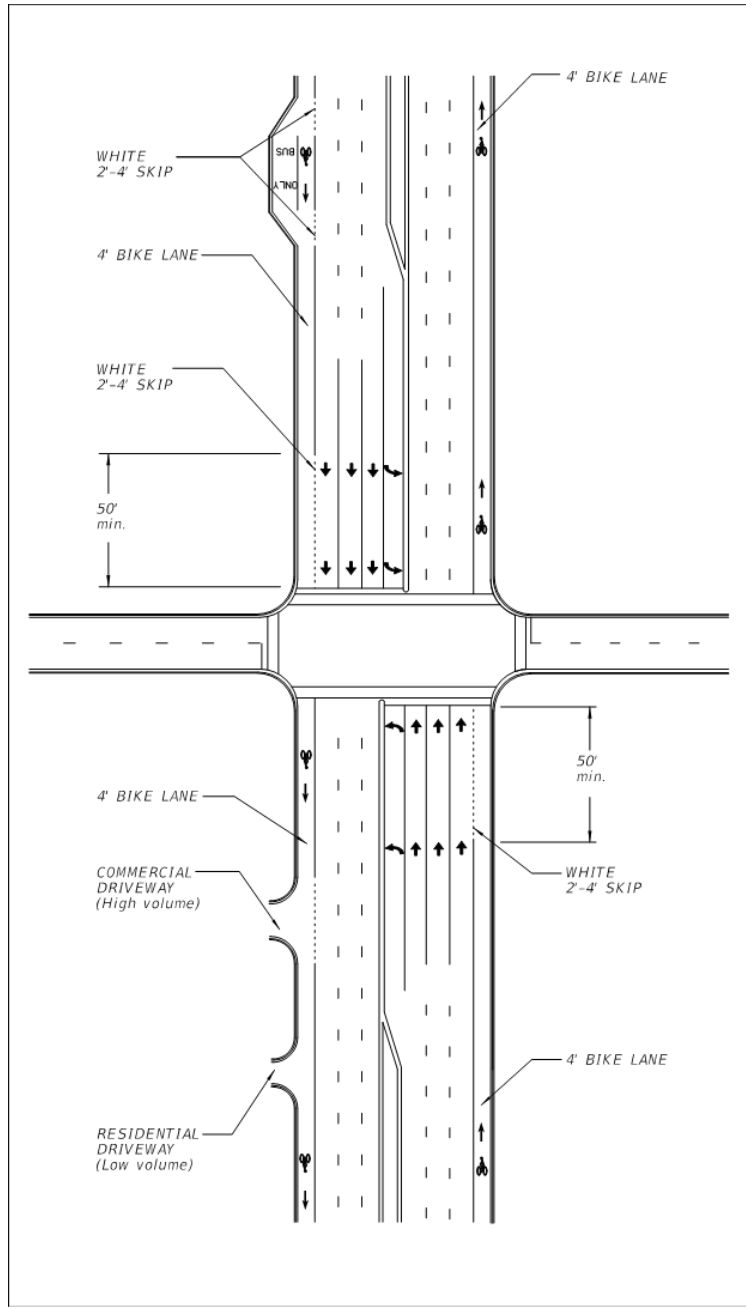
**Figure 9-x Bicycle Lane Markings with Right Turn Lane  
(Flush Shoulder)**



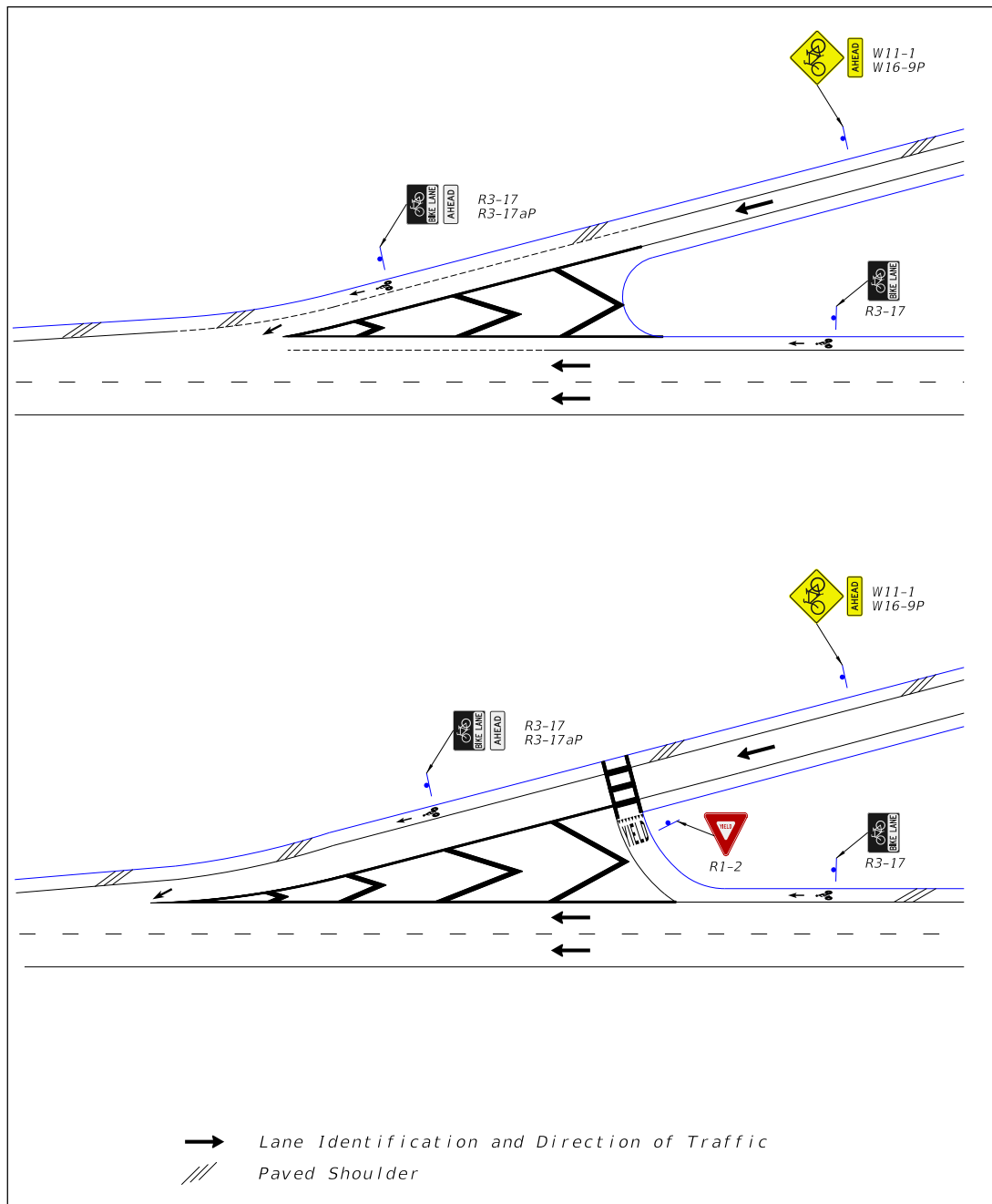
**Figure 9-x Bicycle Lanes with Separate Right Turn Lane, Flush Shoulder**  
**Typical Section**



**Figure 9-x Bicycle Lanes with Bus Bay, No Right Turn Lane, Curb and Gutter  
Typical Section**



**Figure 9-x Bicycle Lanes on Interchange Ramps,  
Flush Shoulder Typical Section**



## **B.2 Buffered Bicycle Lanes**

Buffered bicycle lanes are bicycle lanes separated from either the adjacent travel lane or parking lane with a marked buffer area. They provide greater shy distance between motor vehicles and bicyclists and encourage bicyclists to ride outside of the “door zone” of parked cars. Typical applications include streets with high travel speeds, high traffic volumes, high amounts of truck or transit traffic, or where there are underutilized travel lanes or extra pavement width.

The bicycle lane symbol and arrow markings shall be used, along with longitudinal lines to create the buffer. There are several options for marking the buffer area, including a wide solid double line (crossing prohibited), wide solid single line (crossing discouraged) or wide dotted single line (crossing permitted to make right hand turn). Where the buffer space is wider than 4 feet and crossing the buffer is prohibited, chevron markings should be placed in the buffer area.

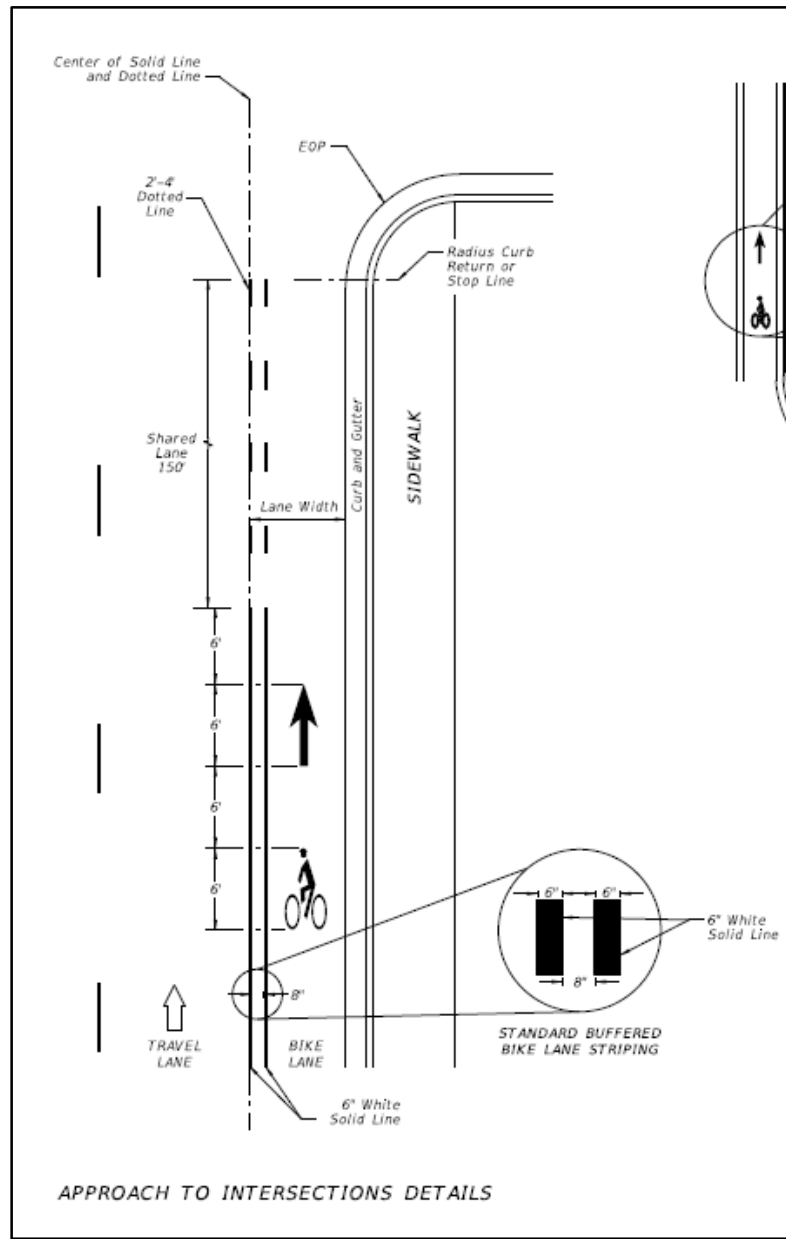
At an intersection approach, the buffer striping should transition to a wide dotted stripe using a 2/4 skip pattern. The transition should begin 150 feet in advance of an intersection to provide sufficient distance for an automobile or truck to merge into the bicycle lane before turning right. Figures 9.x-y provide examples of buffered bicycle lanes. **Chapter 3D. Markings for Preferential Lanes** of the **MUTCD** provides additional information on the striping of buffered bicycle lanes.

Figure 9-x Buffered Bicycle Lane Adjacent to On-Street Parking

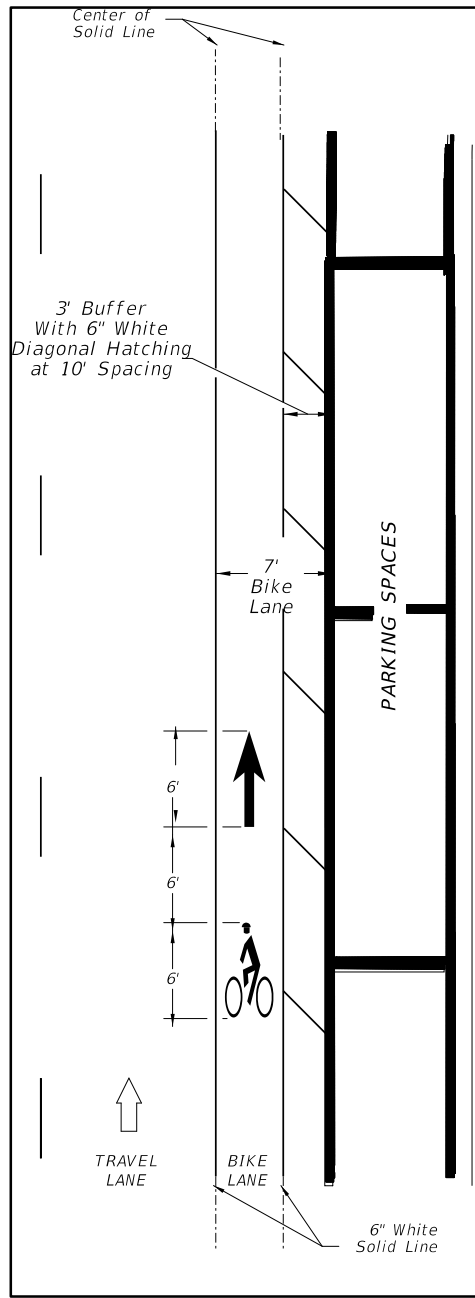


NACTO Urban Bikeway Design Guide, National Association of City Transportation Officials

**Figure 9-x Buffered Bicycle Lane Markings**



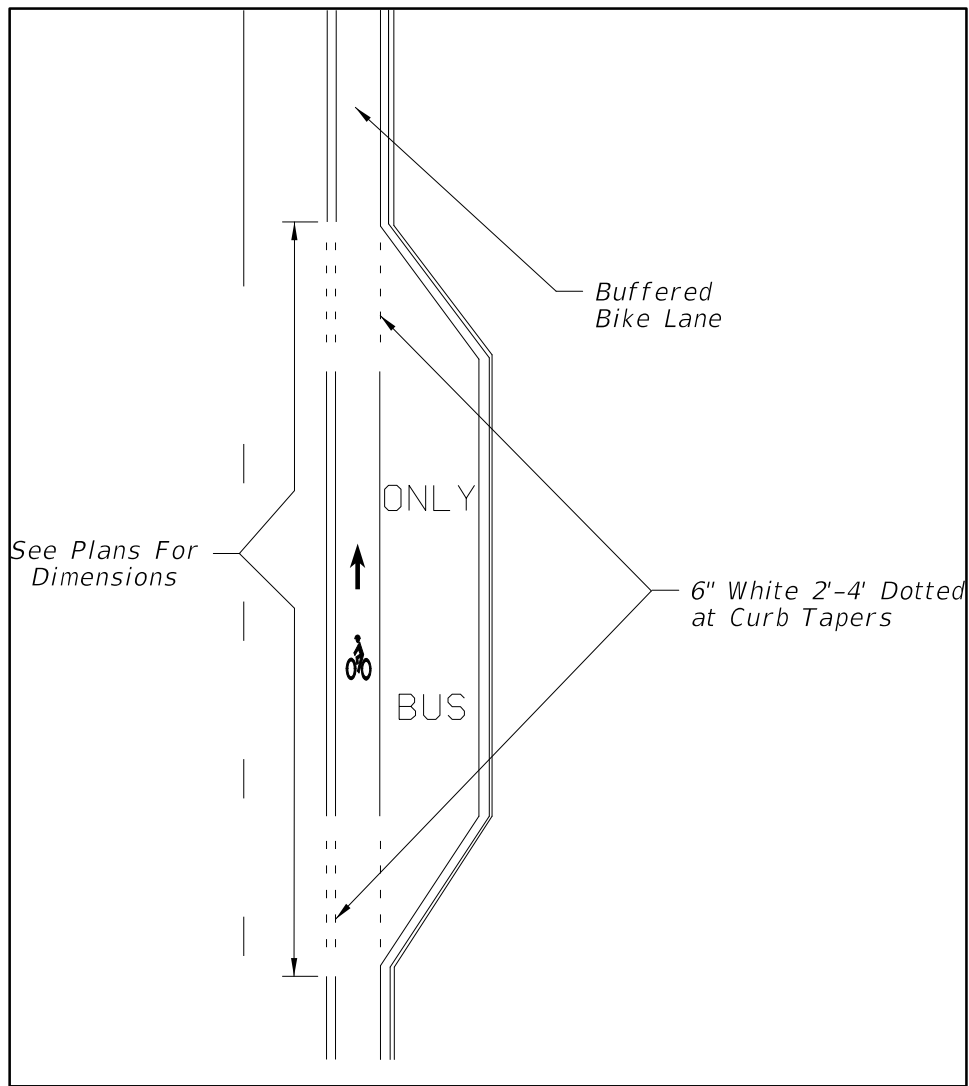
### 9-x Buffered Bicycle Lane Markings with On-Street Parking



### **B.3 Bicycle Lane with Bus Bay**

When a bus bay is provided on roadways with bicycle lanes, the bicycle lane shall be continued adjacent to the bus bay. Figure 9.x provides an example of a buffered bicycle lane with a bus bay.

**Figure 9-x Buffered Bicycle Lane with Bus Bay Marking (Curb and Gutter)**





## **B.4 Green Colored Bicycle Lanes**

The Federal Highway Administration (FHWA) has issued an Interim Approval for the use of green colored pavement in bicycle lanes and in extensions of bicycle lanes through intersections and other traffic conflict areas. Colored pavements shall not replace or be used in lieu of required markings for bike lanes as defined in the **MUTCD**, but shall only supplement such markings. Traffic conflict areas include where the:

- bicycle lane crosses a right turn lane,
- traffic in a right turn lane crosses a bike lane, or
- bicycle lane is adjacent to a dedicated bus bay.

The Interim Approval may be found at the following website and provides further information on how to submit a written request to use green colored pavement:

[http://mutcd.fhwa.dot.gov/res-interim\\_approvals.htm](http://mutcd.fhwa.dot.gov/res-interim_approvals.htm)

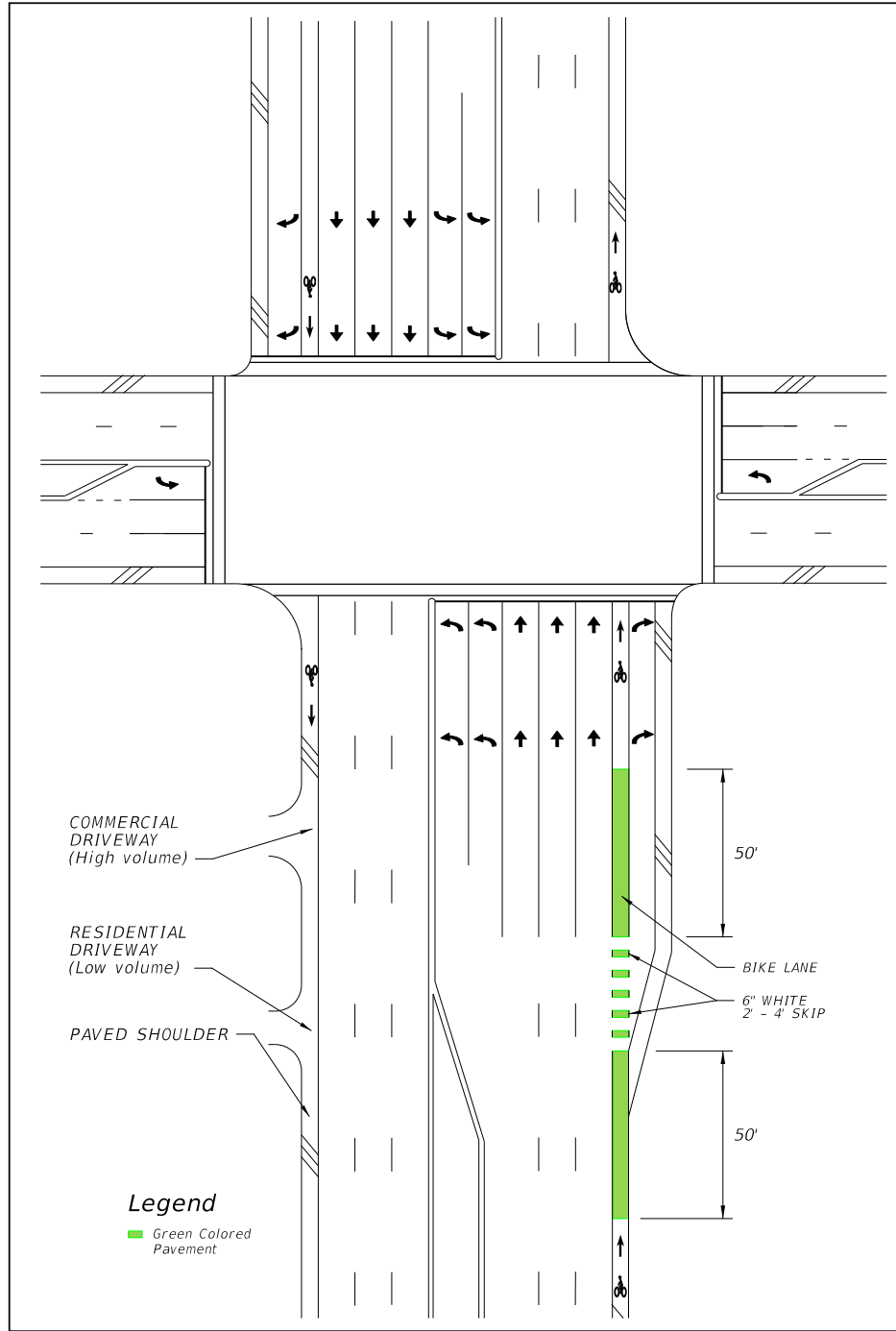
The effectiveness of green colored pavement may be maximized if the treatment is used only where the path of bicyclists and other road users cross and yielding must occur. Because colored pavements are addressed in the 2009 MUTCD, they are by definition a traffic control device whose need should be demonstrated before they are used. A need for this treatment can be demonstrated by either of the following:

1. A history of 3 or more motor vehicle-bicycle crashes exists at or adjacent to the traffic conflict area over the most recent three-year period, or
2. A government agency has observed and documented conflicts (failure of the motor vehicle to yield to the bicyclist) between cyclists and motor vehicles at an average rate of two per peak hour. The documentation for conflicts shall include observations from a minimum of two separate data collection periods, conducted on different days in a one month period, and include at least one weekday and one weekend count period during peak bicycle travel times. Each period should be at least 2 hours in duration. Peak times vary by region and surrounding land use, but are typically:
  - Weekday, 11:00 AM to 1:00 PM
  - Weekday, 5:00 PM to 7:00 PM
  - Saturday, 8:00 AM to 2:00 PM

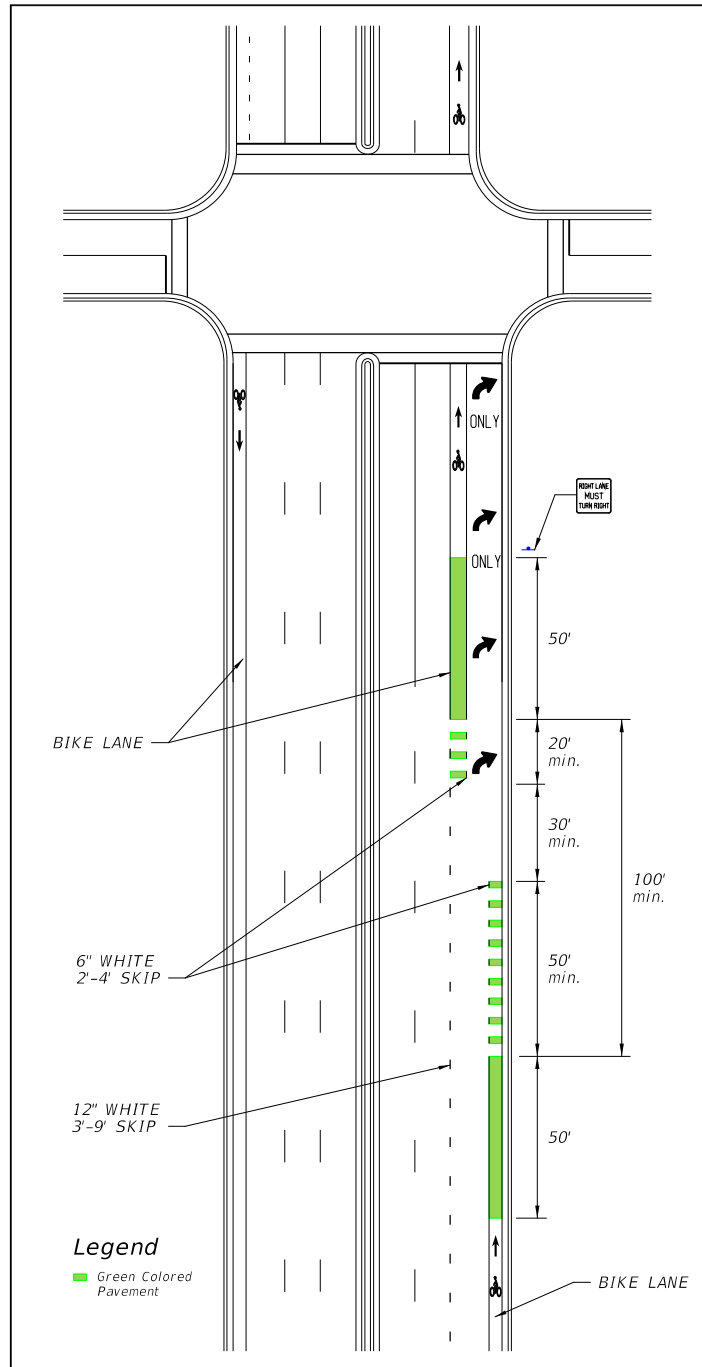
When used in conjunction with white skip lines, such as when extending a bike lane across a right turn lane or access to a bus bay, the transverse colored marking shall match the 2'-4' white skip line pattern of the bike lane extension. The green colored pavement should begin as a solid pattern 50 feet in advance of the skip striping, match the 2' 4' skip through the conflict area, and then resume the solid color for 50' after the conflict area, unless such an extent is interrupted by a stop bar or an intersection curb radius. Details of each installation and associated pavement markings shall be shown in the plans. Figures 9.x – 9x illustrate how the green portion of the bicycle lane may be marked.

Materials permitted to color the bike lane green shall be non-reflective and fall within the color parameters defined by FHWA in their interim approval. Materials which have been tested to meet these requirements can be found in ***FDOT's Approved Product List for Specification 523, Patterned Pavement.***

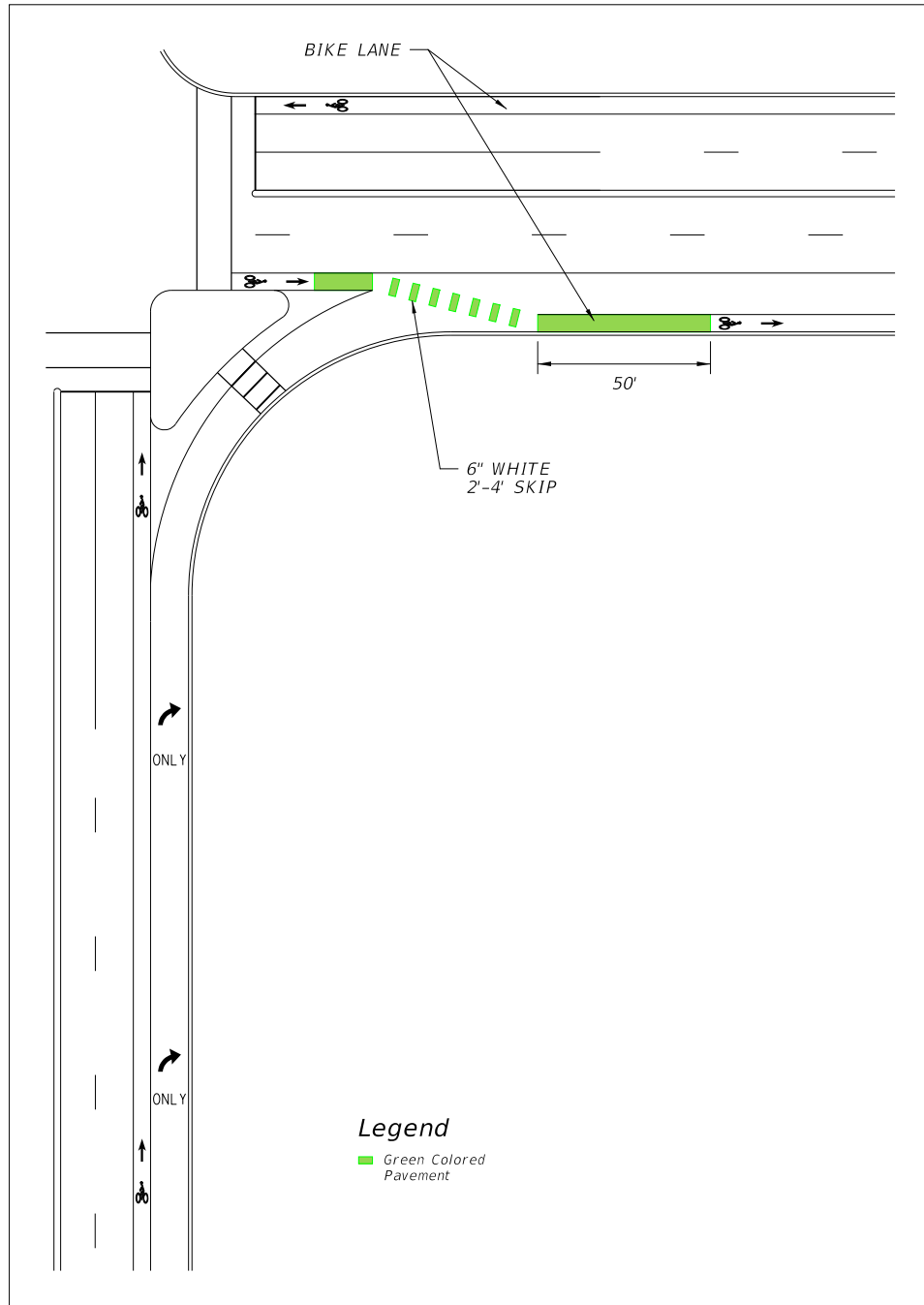
**Figure 9.x Bicycle Lane with Separate Right Turn Lane [KM3]**



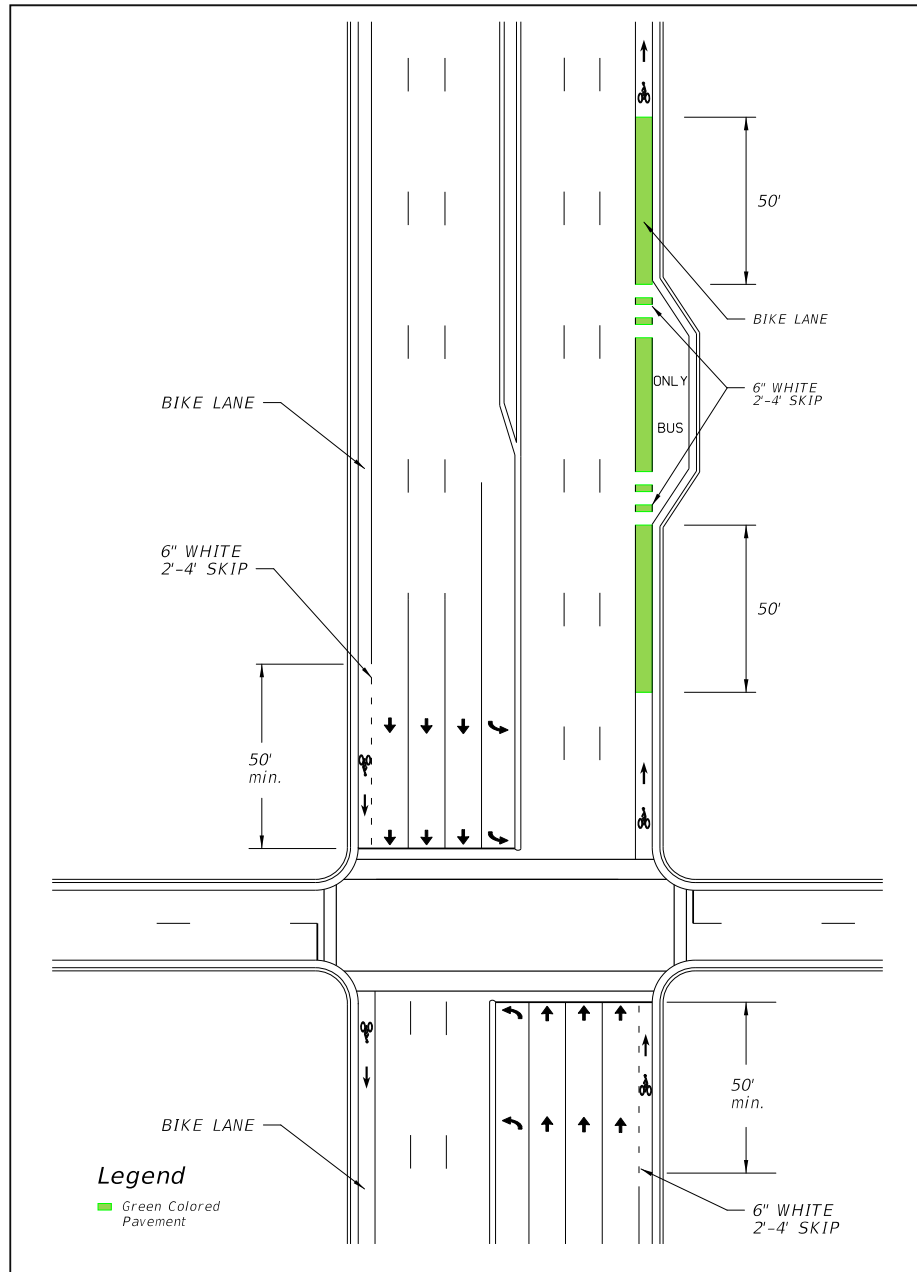
**Figure 9.x Bicycle Lane with Right Turn Drop Lane**



**Figure 9.x Bicycle Lane with Channelized Right Turn Lane**



**Figure 9.x Bicycle Lane with Bus Bay**



## B.52 Paved Shoulders

A paved shoulder is a portion of the roadway which has been delineated by edge line striping, ~~but generally does not include special pavement markings for the preferential use by bicyclists. In some areas, adding, widening or improving paved shoulders often can be an acceptable way to accommodate bicyclists. Paved shoulders 4 feet and wider may be marked as bicycle lanes. A paved shoulder at least 4 feet in width may be considered to be a bicycle facility. However, when a shoulder is intended to serve as a bicycle facility and is adjacent to a curb, guardrail or other roadside barrier, a minimum 5-foot clear width between the traveled way and the face of the barrier is required.~~ Additional shoulder width is desirable if the posted speed exceed 50 mph, or the percentage of trucks, buses, or recreational vehicles is high (>10%). ~~A minimum 5-foot clear width between the traveled way and the face of curb, guardrail or other roadside barrier is recommended.~~

Ground-in rumble strips should not be included in paved shoulders if a minimum clear ~~width~~path of 4 feet outside of the rumble strip cannot be provided.

## B.63 Wide Outside Lanes

~~Wide outside lanes are through lanes which provide a minimum of fourteen feet in width. This width allows most motor vehicles to pass cyclists within the travel lane, which is not possible on more typical 10-foot to 12-foot wide lanes. On stretches of roadway with steep grades where bicyclists need more maneuvering space, the wide curb lane should be slightly wider where practical. In restricted urban conditions, where it is not possible to include bicycle lanes or paved shoulders or on minor collector streets, a wide curb lane may be a practical option for a bicycle facility. However, in situations where more than 15 feet of pavement width exists, bicycle lanes or paved shoulders should be provided.~~ Wide outside lanes on curbed roadways are through lanes that provide a minimum of 14 feet in width, which allows most motor vehicles to pass cyclists safely within the travel lane. Bicycle lanes are preferred for arterial and collector roadways, however, in some conditions, such as resurfacing projects, wide outside lanes may be the only practical option for a bicycle facility.

## **B.74 Shared Lane Markings**

The sShared lane markings, \_ais an optional pavement marking for roadways where bicyclists and motor vehicles are intended to share the lane and no bicycle lane or paved shoulder exists or is feasible. Shared lane markings should be limited to roadways with a posted speed of 35 mph or less. They are not intended to be placed on every roadway without bicycle facilities or on shared use paths.

Shared lane markings provide guidance to cyclists on their lateral positioning, especially on roadways with on-street parking or lanes that are too narrow to share side by side with a motor vehicle. They also help to discourage wrong way riding and encourage safer passing of bicyclists by motorists. Shared lane markings may be used to identify an alternate route as part of an approved temporary traffic control plan.

Shared lane markings should be placed as follows:

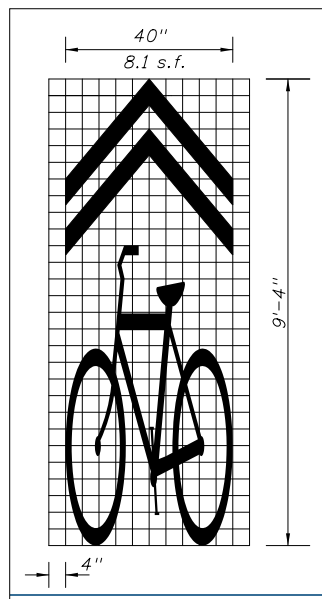
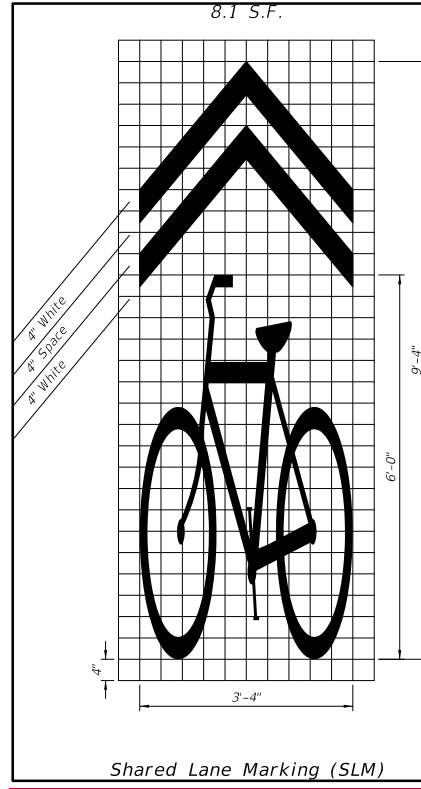
- If used on a roadway without on-street parking that has an outside travel lane that is 14 feet wide or less, the Shared Lane Markings should be centered in the travel lane (Figure 9-x).
- If used on a roadway with on-street parking, the Shared Lane Markings should be centered in the travel lane (Figure 9-x).
- Shared Lane Markings should be placed immediately after an intersection and spaced at intervals not greater than 250 feet thereafter.



~~s shown in Figure 9-3 may be used in travel lanes to indicate the optimum alignment for a bicyclist within the lane and to inform road users that bicyclists might occupy the travel lane. Shared Lane Markings shall not be placed in bicycle lanes or on paved shoulders. Shared Lane Markings should not be placed on roadways that have a posted speed limit above 35 mph. The Shared Lane Markings may be used to:~~

- ~~• Assist bicyclists with lateral positioning in a shared lane with on-street parallel parking in order to reduce the chance of a bicyclist's impacting the open door of a parked vehicle,~~
- ~~• Assist bicyclists with lateral positioning in lanes that are too narrow for a motor vehicle and a bicycle to travel side by side within the same travel lane,~~
- ~~• Alert road users of the lateral location bicyclists are likely to occupy within the traveled way,~~
- ~~• Encourage safe passing of bicyclists by motorists, and~~
- ~~• Reduce the incidence of wrong-way bicycling.~~

**Figure 9-x3 Shared Lane Marking**



**Figure 9-xx5 Shared Lane Marking Placement (No Designated Parking)**  
**(Lane Width  $\leq$  14 Feet)**

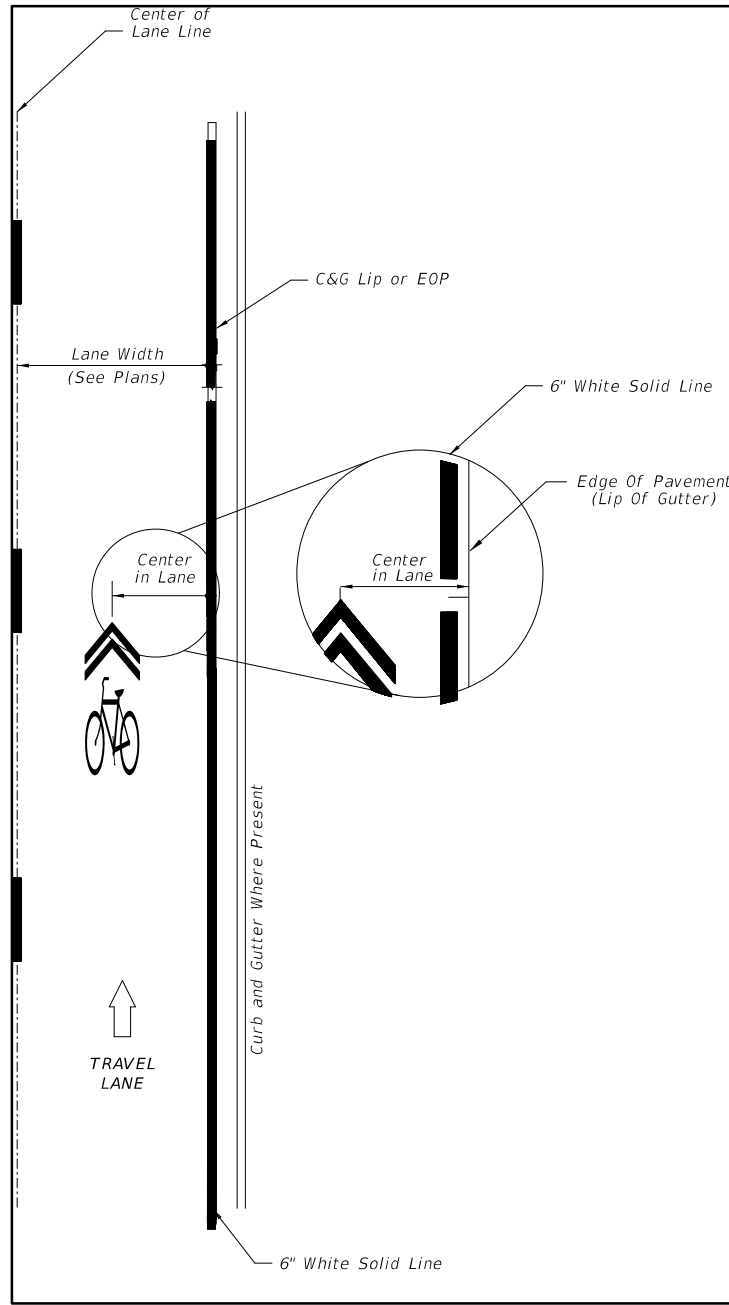
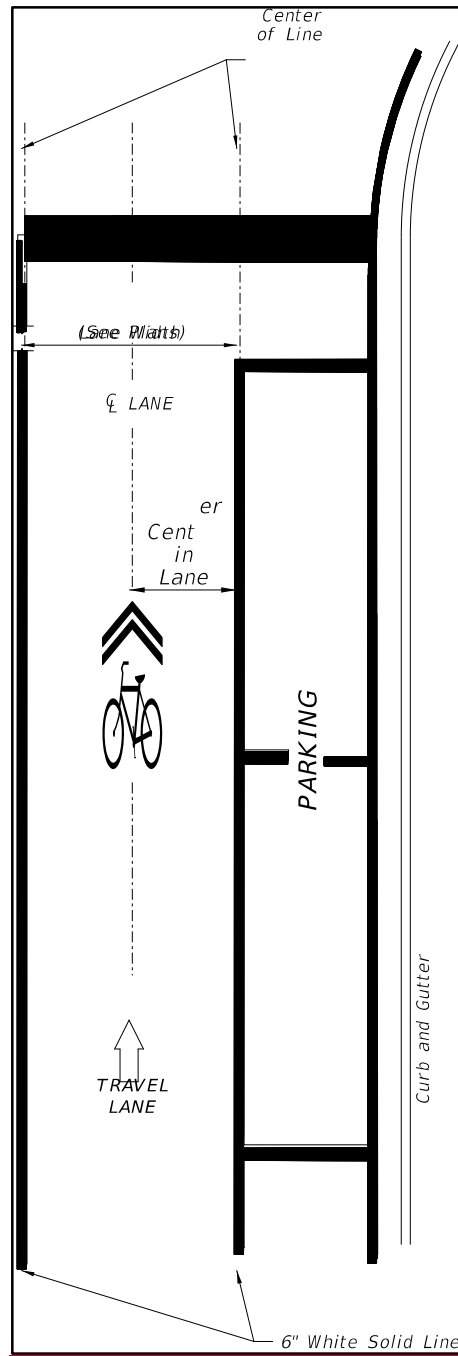
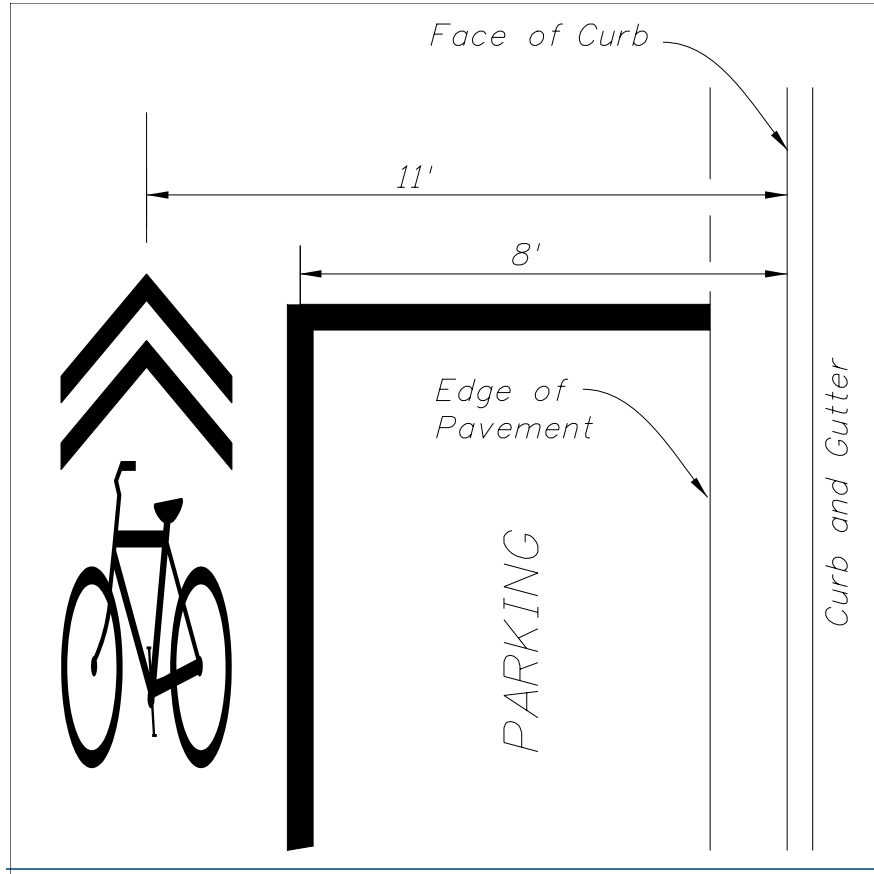
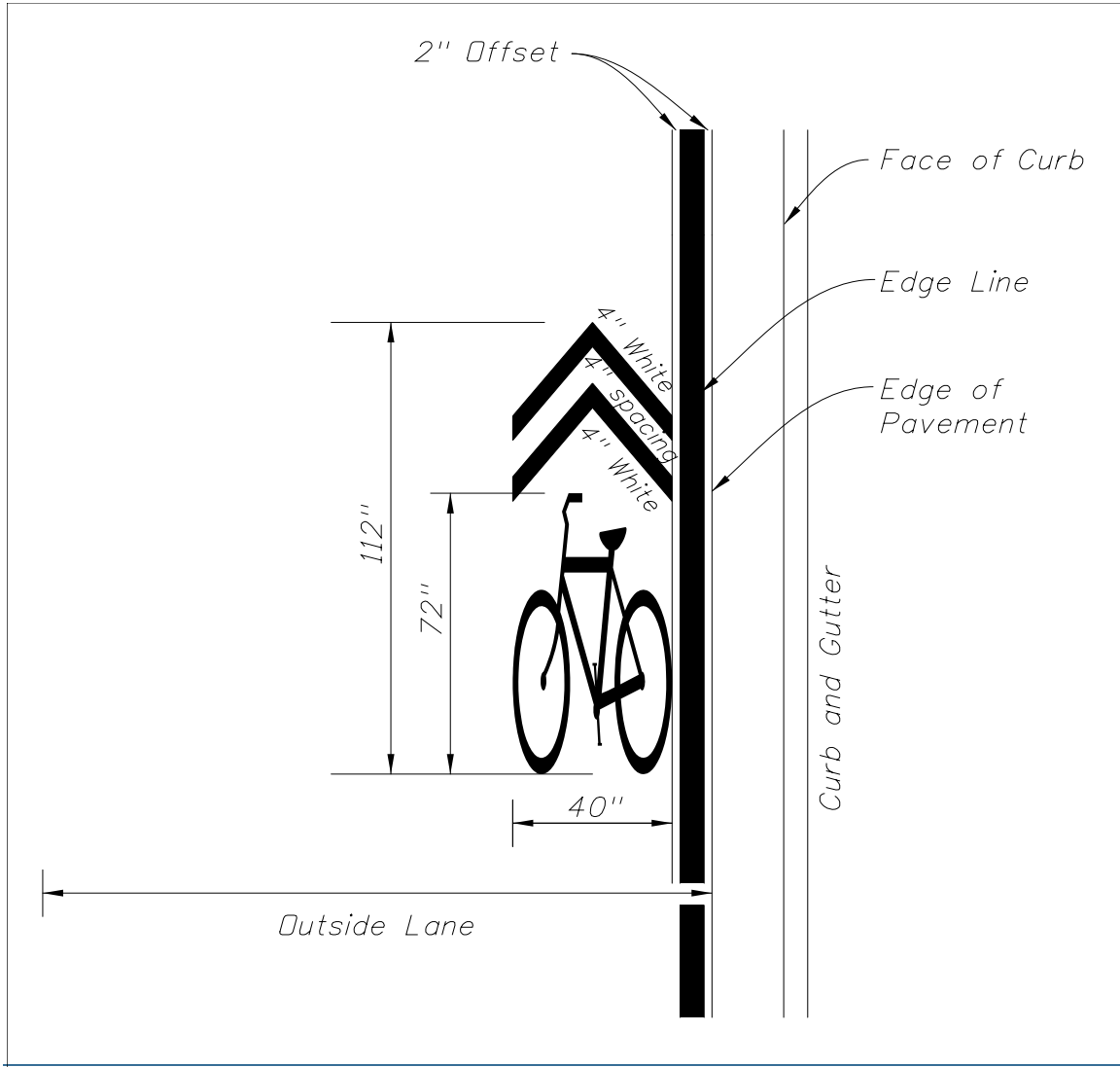


Figure 9-xx4 Shared Lane Marking Placement (With On-Street Parking)







## **B.8 Bicycles May Use Full Lane Sign**

The Bicycle May Use Full Lane sign (R4-11) may be used on roadways where no bicycle lanes or adjacent shoulders useable by bicyclists are present and where travel lanes are less than 14' wide. The MUTCD provides additional information on the use of the sign.

## **C Shared Use Paths**

Shared use paths are paved facilities physically separated from motorized vehicular traffic by an open space or barrier and either within the highway right of way or an independent right of way usually on an exclusive right of way, with minimal cross flow by motor vehicles. They are used by bicyclists, pedestrians, runners joggers, in-line skaters, bicyclists, and in some cases equestrians. The bicycle's operating characteristics will govern the design of shared use paths. The 2006 Americans with Disabilities Act – Standards for Transportation Facilities and the 2012 Florida Accessibility Code impose additional requirements for the design and construction of shared use paths since they serve as pedestrian facilities.

–Shared use paths serve a variety of purposes. They can provide a school age child, a recreational cyclist, or a person with a disability an alternative to busy roadways. Shared use paths can be located along former rail corridors, the banks of rivers or canals, and through parks and forests. Shared use paths can also provide access to areas otherwise served only by limited access highways. For transportation purposes, they should be thought of as an extension of the roadway network for non-motorized users. The inclusion of a shared use path should not be considered as an alternative to providing on-street facilities, but, rather, as a supplement.

accessibilityRaton”

For additional information discussion on shared use path design, beyond what is in this chapter, refer to the AASHTO Guide for the Development of Bicycle Facilities (2012, 4<sup>th</sup> Edition).

### **C.1 Width and Clearance**

The useable width and horizontal clearance for a shared use path are primary design considerations. The minimum paved width for a two-way path is 10 feet. Typically, widths range from 10 to 14 feet, with the wider values applicable to areas

with high use or a wider variety of users, on steep grades, through curves, or used by larger maintenance vehicles.

In very rare circumstances, a reduced width of 8 feet may be used where the following conditions prevail:

- Bicycle traffic is expected to be low, even on peak days or during peak hours.
- Pedestrian use of the facility is not expected to be more than occasional.
- Horizontal and vertical alignments provide frequent, well-designed passing and resting opportunities.
- The path will not be regularly subjected to maintenance vehicle loading conditions that would cause pavement edge damage.

In addition, a path width of 8 feet may be used for a short distance due to a physical constraint such as an environmental feature, bridge abutment, utility structure, or fence.

A minimum 2 foot wide graded area with a maximum 1:6 slope should be maintained adjacent to both sides of the path; however, 3 feet or more is desirable to provide clearance from trees, poles, walls, fences, guardrails or other lateral obstructions. Where the path is adjacent to canals, ditches, or slopes steeper than 1:3, a wider separation should be considered. A minimum 5 foot separation from the edge of the path pavement to the top of the slope is desirable. Depending on the height of embankment and condition at the bottom, a physical barrier, such as a railing or chain link fence may need to be provided.

Where a recovery area is less than 5 feet, physical barriers or rails are recommended in the following situations:

- Slopes 1:3 or steeper, with a drop off of 6 feet or greater;
- Slopes 1:3 or steeper, adjacent to a parallel body of water or other substantial obstacle
- Slopes 1:2 or steeper with a drop of 4 feet or greater; and
- Slopes of 1:1 or steeper, with a drop of 1 foot or greater.



The AASHTO Guide for the Development of Bicycle Facilities (2012, 4<sup>th</sup> Edition) provides additional information on the design of barriers or railings.

The desirable vertical clearance to obstructions is 10 feet. Fixed objects should not be permitted to protrude within the vertical or horizontal clearance of a shared use path. The recommended minimum vertical clearance that can be used in constrained areas is 8 feet. In some situations, vertical clearance greater than 10 feet may be needed to permit passage of maintenance and emergency vehicles.

## **C.21 Separation ~~B~~etween Shared Use Paths and Roadways**

When shared use paths are located adjacent to a roadway, a separation shall be provided. This demonstrates to both path users and motorists that the shared use path is a separate facility.

The minimum distance between a path and the face of curb or edge of traveled way (where there is no curb) should be 5 feet. On roadways with flush shoulders, this separation is measured from the outside edge of the shoulder to the inside edge of the path. Where the separation is less than 5 feet, a physical barrier or railing should be provided between the path and the roadway.

A barrier or railing between the path and adjacent highway should not impair sight distance at intersections, and should be designed to limit the potential for injury to errant motorists or bicyclists. The barrier or railing need not be of size and strength to redirect errant motorists toward the roadway, unless other conditions indicate the need for a crashworthy barrier.

Barriers or railings at the outside of a structure or steep fill embankment that not only define the edge of the path but also prevent bicyclists from falling over the rail to a substantially lower elevation should be a minimum of 42" high. Barriers at other locations that serve only to separate the area for motor vehicles from the path should generally have a minimum height equivalent to the height of a standard guard rail.

When a path is placed along a high-speed highway, a separation greater than 5 feet is desirable.

~~Shared use paths should be separated from the roadway. In some cases, paths along highways for short sections are permissible, given an appropriate level of separation between facilities. Some problems with paths located immediately adjacent to the roadways are as follows:~~

- ~~Unless separated, they require one direction of bicycle traffic to ride against motor vehicle traffic, contrary to normal rules of the road.~~
- ~~When paths end, bicyclists going against traffic will tend to continue to travel on the wrong side of the street. Likewise, bicyclists approaching a path often travel on the wrong side of the street to get to the path. Wrong-way travel by bicyclists is a major cause of bicycle/automobile crashes and should be discouraged at every opportunity.~~
- ~~At intersections, motorists entering or crossing the roadway often will not notice bicyclists coming from the right, as they are not expecting or looking for contra-flow vehicles. Motorists turning to exit the roadway may likewise fail to notice the bicyclists. Even bicyclists coming from the left (the expected direction) often go unnoticed, especially when sight distances are limited.~~
- ~~When constructing a two-way path within a narrow right of way, sacrificing the shoulder on the adjacent roadway would be a detriment to both the motorist and the bicyclists and should be avoided if at all possible.~~
- ~~Many bicyclists will use the roadway instead of the shared use path because they have found the roadway to be safer, less congested, more convenient, or better maintained. Bicyclists using the roadway are often subjected to harassment by motorists who feel that, in all cases, bicyclists should be on the path instead.~~
- ~~Although the shared use path should be given the same priority through intersections as the parallel highway, motorists falsely expect bicyclists to stop or yield at all cross streets and driveways. Efforts to require or encourage bicyclists to yield or stop at each cross street and driveway are inappropriate and frequently ignored by bicyclists.~~
- ~~Stopped cross street motor vehicle traffic or vehicles exiting side streets or driveways may block the path crossing.~~
- ~~Because of the proximity of motor vehicle traffic to opposing bicycle traffic, barriers are often necessary to keep motor vehicles out of shared use paths and bicyclists out of traffic lanes. These barriers can represent an obstruction to bicyclists and motorists, can complicate maintenance of the facility, and cause other problems.~~

~~When it is decided to construct a shared use path adjacent to a roadway, the~~

following should be considered.

- ~~Conflict points should be limited to as few as possible.~~
- ~~Conflicts should occur at as low a speed as possible. Consider reducing turning radii to reduce the speeds of motorists turning toward the shared use path. Kinks in the path alignment can reduce the speed of path users approaching the conflict.~~
- ~~Maintain adequate sight distances for both motorists and path users to perceive and react to potential conflicts.~~

~~When the distance between the shared use path and the highway shoulder is less than 5 feet, a physical barrier is recommended. Where used, the barrier should be a minimum of 42 inches high, to prevent cyclists from toppling over it. A barrier between a shared use path and an adjacent highway should not impair sight distance at intersections, and should be designed to not be a hazard to errant motorists.~~ oca Ratonto whether a s

## ~~C.2~~ **Width**

~~The paved width and operating width required for a shared use path are primary design considerations. The minimum recommended width for a paved two-way path is 10 feet. In many cases, it is desirable to increase the minimum width to 12 feet. The width should be increased if there is expected substantial use by bicyclists, probable shared use with joggers and in-line skaters, steep grades, and locations where bicyclists are likely to ride two abreast.~~

~~In a few cases, it may be acceptable to decrease the trail width to 8 feet. This width should only be used where the following conditions prevail:~~

- ~~Bicycle traffic is expected to be low, even on peak days or during peak hours.~~
- ~~Pedestrian use of the facility is not expected to be more than occasional.~~
- ~~There will be good horizontal and vertical alignment, providing safe and frequent passing opportunities.~~
- ~~During normal maintenance activities, the path will not be subjected to maintenance vehicles causing pavement edge damage.~~

~~For further discussion of shared use path design, refer to the Florida Bicycle Facilities Planning and Design Handbook.~~

### ~~C.3~~ Horizontal Clearance

~~A minimum 2 foot wide graded area with a maximum 1:6 slope should be maintained adjacent to both sides of the path; however, 3 feet or more is desirable to provide clearance from trees, poles, walls, fences, guardrails or other lateral obstructions. Where the path is adjacent to canals, ditches, or slopes steeper than 1:3, a wider separation should be considered. A minimum 5 foot separation from the edge of the path pavement to the top of the slope is desirable. Depending on the height of embankment and condition at the bottom, a physical barrier, such as dense shrubbery, railing or chain link fence, may need to be provided.~~

### C.4 Vertical Clearance

~~Vertical clearance to obstructions should be a minimum of 8 feet. However, vertical clearance may need to be greater to permit passage of maintenance and emergency vehicles. In undercrossings esand tunnels, 10 feet is desirable.~~

### C.35 Design Speed

For paths in relatively flat areas (grades less than or equal to 4%), a design speed of 18 mph shall be used. When a sustained downgrade of 6 percent or greater exists, a design speed of 30 mph should be used.

~~A design speed of 20 mph should be used for shared use paths.~~

### C.4 Horizontal Alignment

The typical adult bicyclists is the design user for horizontal alignment. Please refer to the AASHTO Guide for the Development of Bicycle Facilities (2012, 4<sup>th</sup> Edition) for further information on determining the minimum radius of curves on shared use paths.

Shared use paths should be transitioned as necessary towards the roadway at intersections to provide a more functional crossing location that also meets driver expectation.

## **C.5 Accessibility**

Since nearly all shared use paths are intended to be used by pedestrians, they fall under the accessibility requirements of the Americans with Disabilities Act.

Pull boxes, manholes (and other utility covers), and other types of existing surface features in the location of a proposed curb ramp or detectable warning should be relocated when feasible. When relocation is not feasible, the feature shall be adjusted to meet the ADA requirements for surfaces (including the provision of a nonslip top surface, and adjustment to be flush with and at the same slope as the adjacent surface).

The detectable warning systems are designed to work with concrete surfaces. In areas where the path has an asphalt surface, the engineer must specify an appropriate detectable warning system. In these cases, consider including a short section of concrete that will accommodate any system.

If curb ramps are included in the path design, they should be parallel to and the full width of the approaching path width. Shared use path crossings shall meet the same grade and cross slope requirements as sidewalks where the grade should not exceed 5%, and the maximum cross slope shall be no more than 2%.

Project design shall include an evaluation of existing driveways to determine if it is feasible to upgrade nonconforming driveway turnouts to meet maximum cross slope criteria. Nonconforming driveways are not required to be upgraded if it is not feasible within the scope of the project.

CHAPTER 8 – PEDESTRIAN FACILITIES provides additional information regarding accessible design of shared use paths.

## **C.6 Structures**

The minimum clear width on structures should be the same as the approach shared use path, plus the minimum 2 foot wide clear areas. Access by emergency, patrol and maintenance vehicles should be considered in establishing the design clearances of structures on shared use paths. Where practical, a path vertical clearance of 10 feet (on the structure) is desirable for adequate vertical shy distance.

Grades on structures to be used by pedestrians shall be designed to be accessible. ~~comply with the requirements of the~~ The 2006 Americans with Disabilities Act – Standards for Transportation Facilities and the 2012 Florida Accessibility Code impose additional requirements for the design and construction of shared use path structures. ~~ADA Accessibility Guidelines (as described in the Federal Register) and the Florida Accessibility Code For Building Construction as given in CHAPTER 3 – GEOMETRIC DESIGN.~~

### **C.7 Ramp Widths**

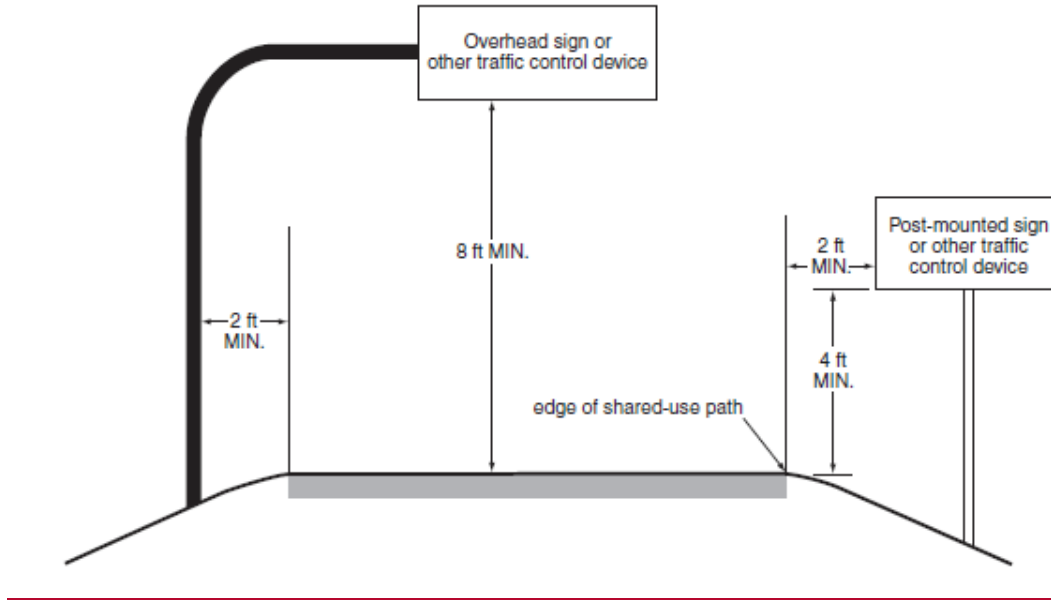
~~Ramps for curbs at intersections should be at least the same width as the shared use path. Curb cuts and ramps should provide a smooth transition between the shared use path and the roadway. A 5 foot radius or flare may be considered to facilitate right turns for bicyclists.~~ Sokolow

### **C.7 Pavement Markings and Signage**

The MUTCD regulates the design and use of all traffic control devices on shared use paths. Figure 9.x provides the minimum criteria for the placement of signs along or over a shared use path. The maximum height from the outside edge of the path to the bottom elevation of a sign is five feet. Signs on shared use paths should follow the dimensions provided in **Table 9B-1 Bicycle Sign and Plaque Sizes, MUTCD.** Guidance on the placement of stop or yield lines and crosswalks on roadways intersecting with shared use paths is provided in the **MUTCD, Part 3.**

**Figure 9.x Sign Placement on Shared Use Paths**

**Figure 9B-1. Sign Placement on Shared-Use Paths**



## D Railroad Crossings

Railroad-highway grade crossings should ideally be at a right angle to the rails. This can be accomplished either as a separate path or a widened shoulder. The greater the crossing deviated from this ideal crossing angle, the greater is the potential for a bicyclist's front wheel to be trapped in the flangeway, causing loss of steering control. If the crossing angle is less than approximately 45 degrees, an additional paved shoulder of sufficient width should be provided to permit the bicyclist to cross the track at a safer angle, preferable perpendicularly. Where this is not possible, and where train speeds are low, commercially available compressible flangeway fillers may enhance bicyclist operation. It is also important that the roadway approach be at the same elevation as the rails. For more information, see Figure [4-28](#) in the AASHTO Guide for the Development of Bicycle Facilities.

## E Structures

All new bridges over roadways and shared use paths shall be designed to meet the vertical clearance standards specified in Chapter 3, Section C.7.j.4.(b), and Chapter 17, Section C.3.b.

All bridges that include provisions for pedestrians shall provide pedestrian accommodations and design considerations that meet the provisions of the ADA.

Bridges over roadways should be covered or screened to reduce the likelihood of objects being dropped or thrown below. If the bridge is enclosed, the visual tunnel effect may require widening the bridge to provide a feeling of security for all bridge users. The area adjacent to overpasses may be fenced to prevent unsafe crossings and to channel pedestrians to the vertical separation structure.



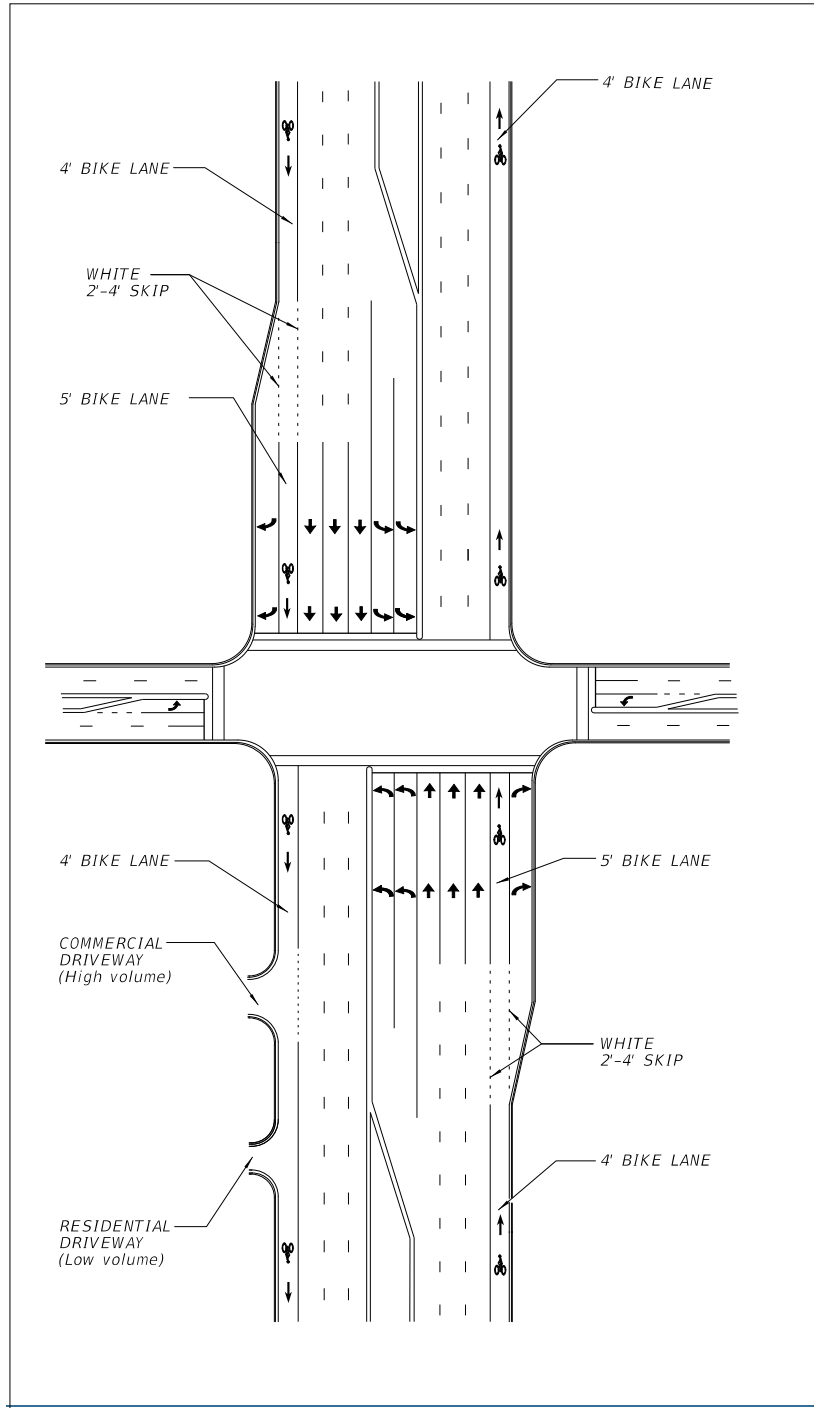
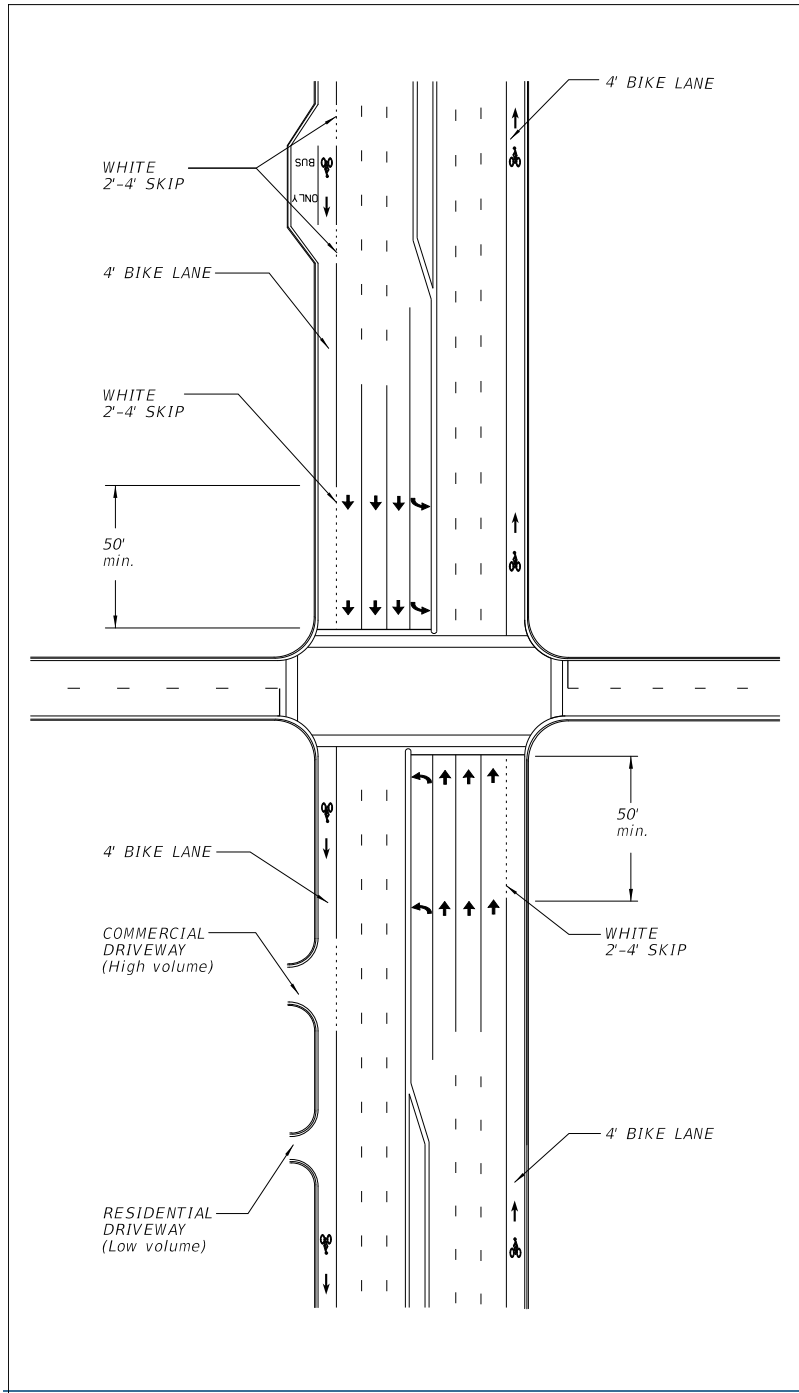
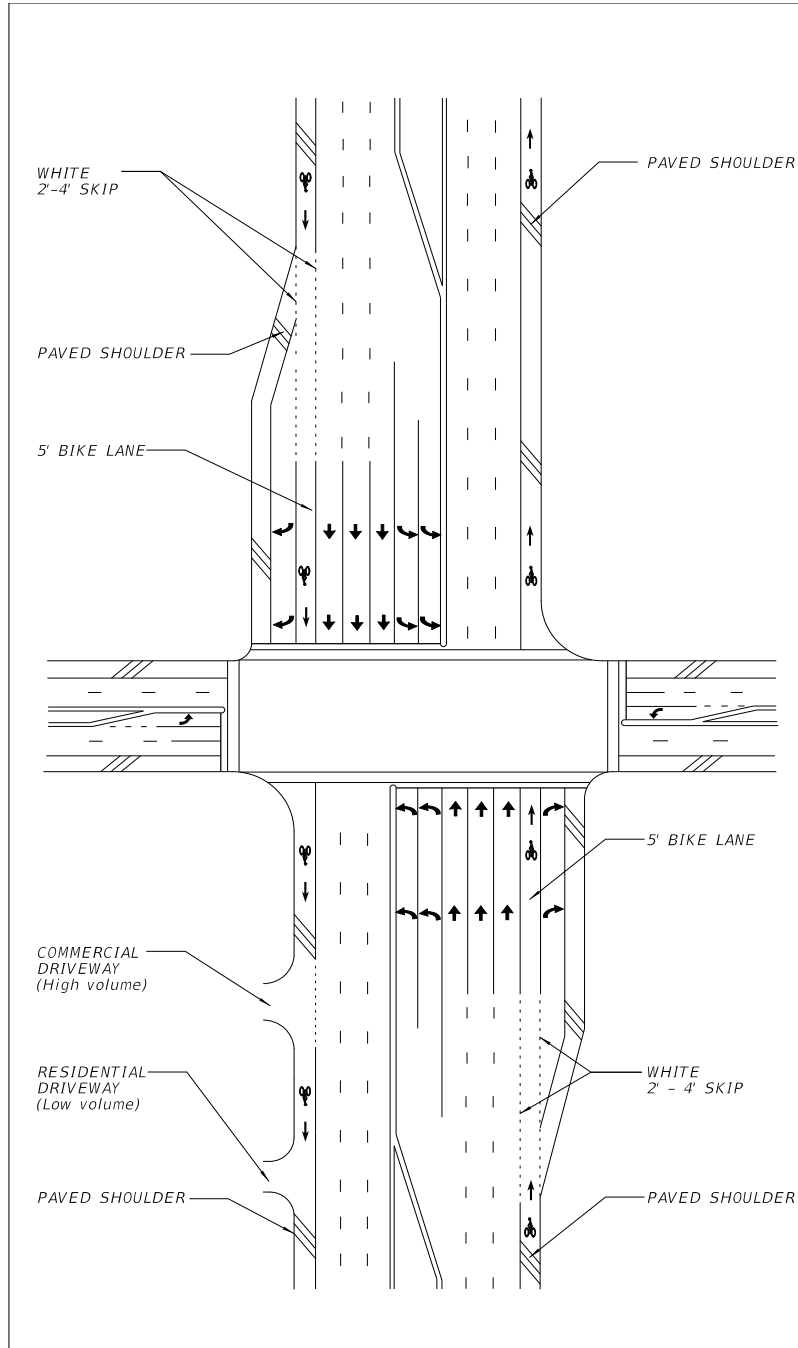


Figure 9-7 — Bicycle Lanes with Bus Bay, No Right Turn Lane, Curb and Gutter Typical Section

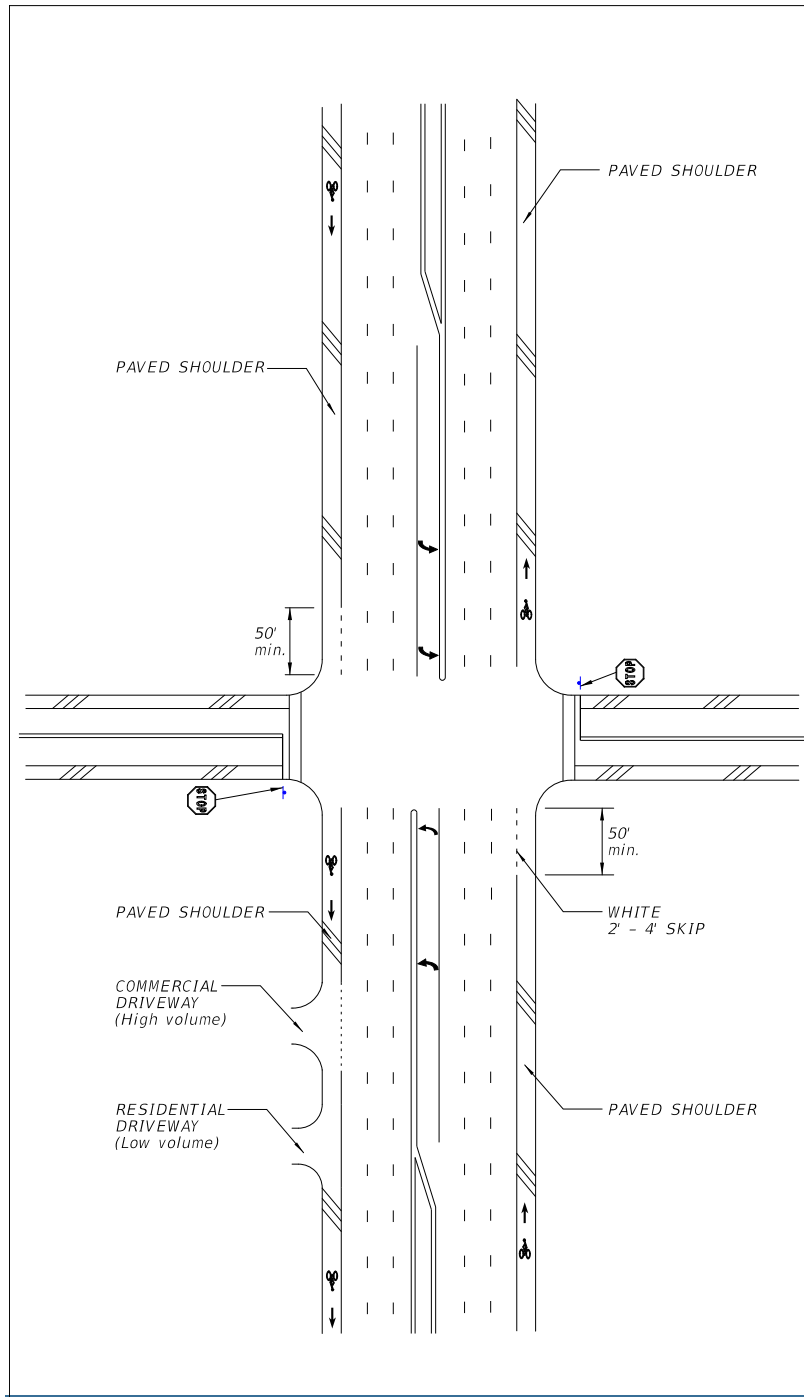


~~Figure 9-8 — Bicycle Lanes with On Street Parking, No Right Turn Lane, Curb and Gutter Typical Section~~  
draft lanes improvements such as buffered bike lanes

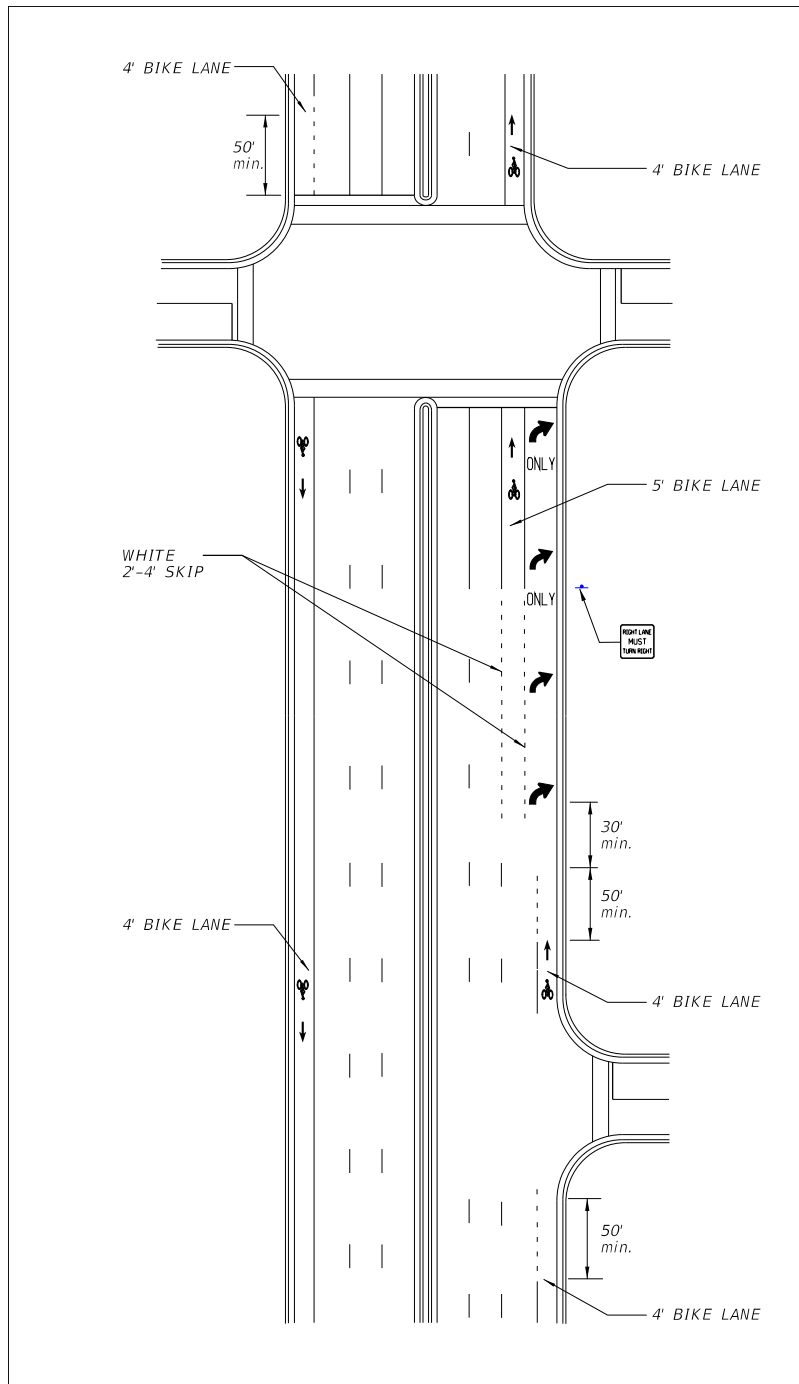
~~Figure 9-9 Bicycle Lanes with Separate Right Turn Lane, Flush Shoulder  
Typical Section~~



**Figure 9-10 — Bicycle Lanes with No Right Turn Lane, Flush Shoulder  
Typical Section**

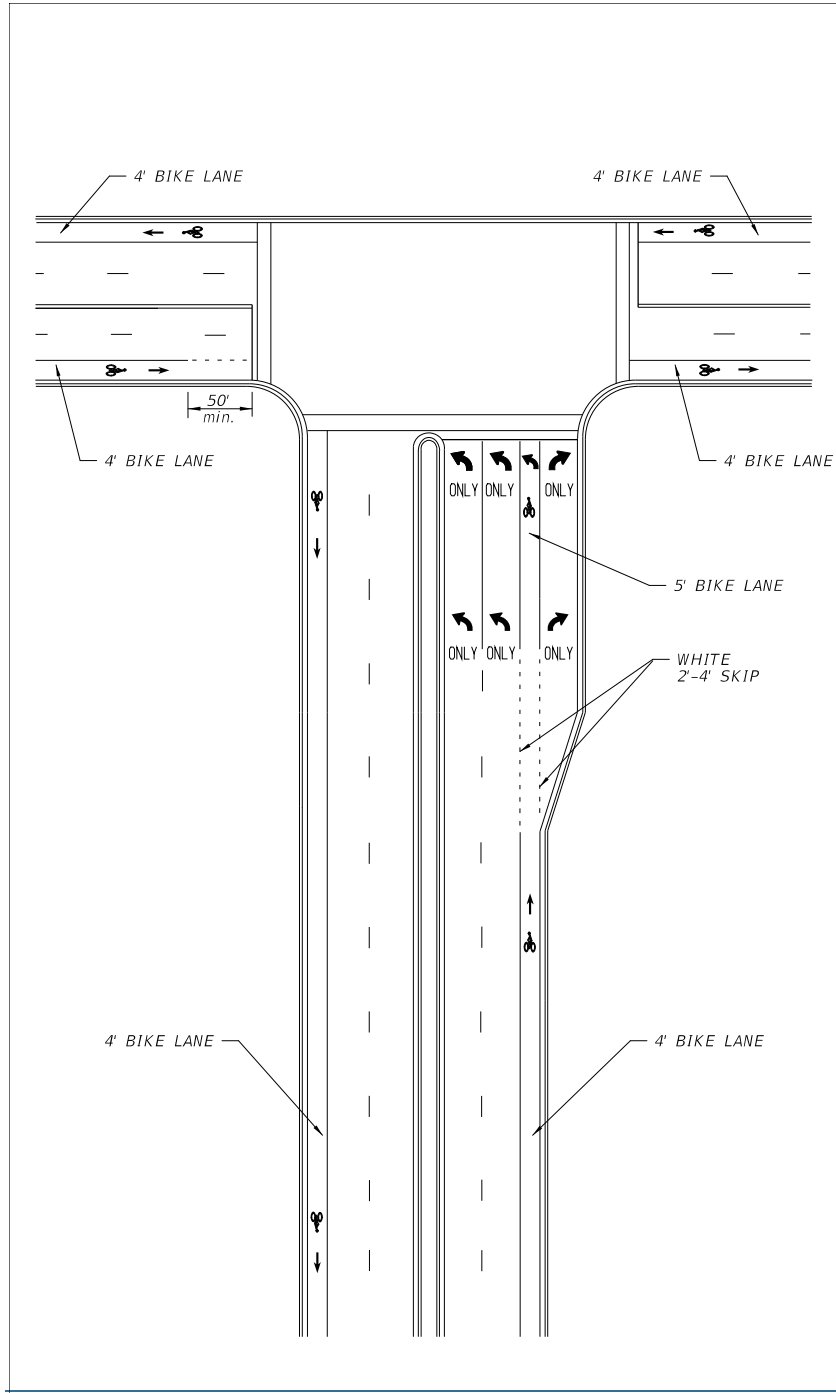


**Figure 9-11 — Bicycle Lane with Right Turn Drop Lane, Curb and Gutter  
Typical Section**

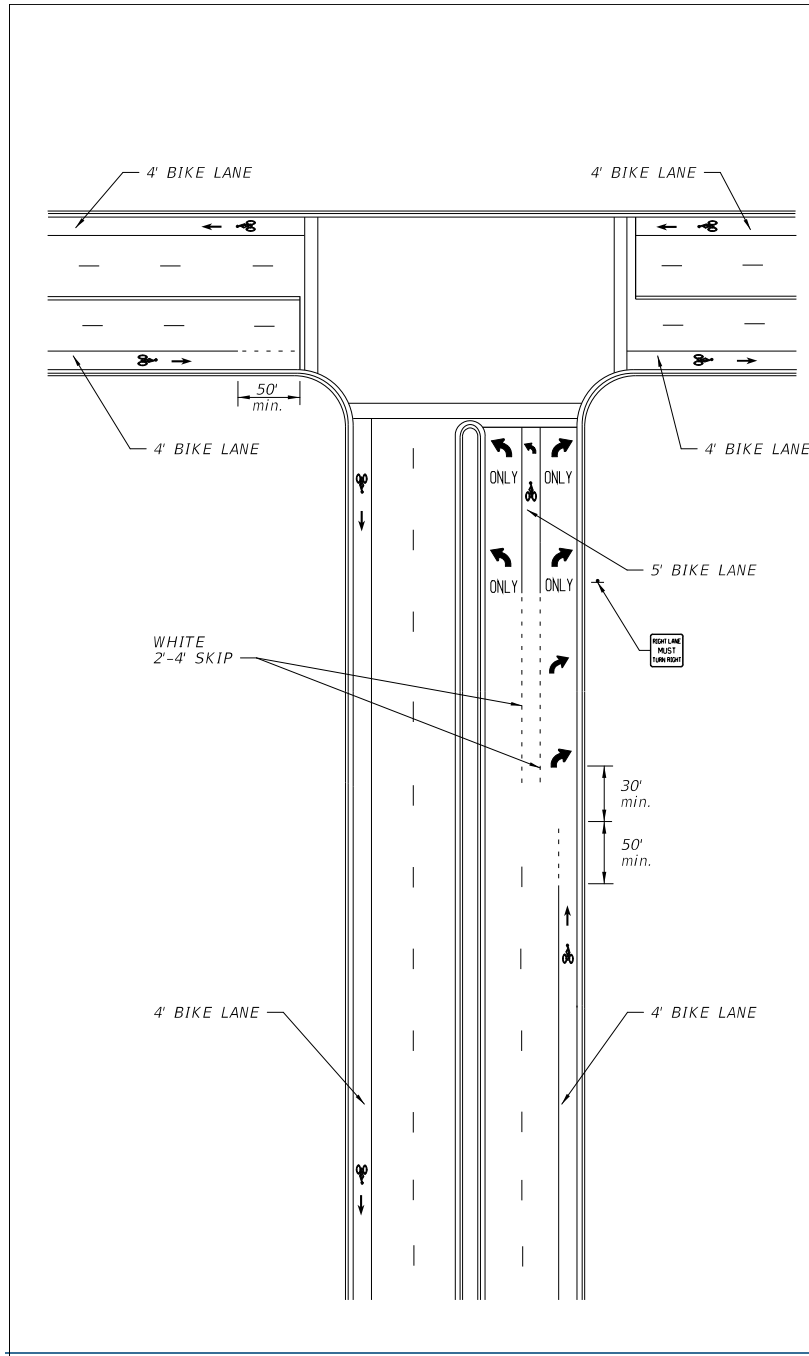


~~Figure 9-12 "Tee" Intersection with Bicycle Lane, Separate Right and Left Turn Lanes,  
Curb and Gutter Typical Section~~

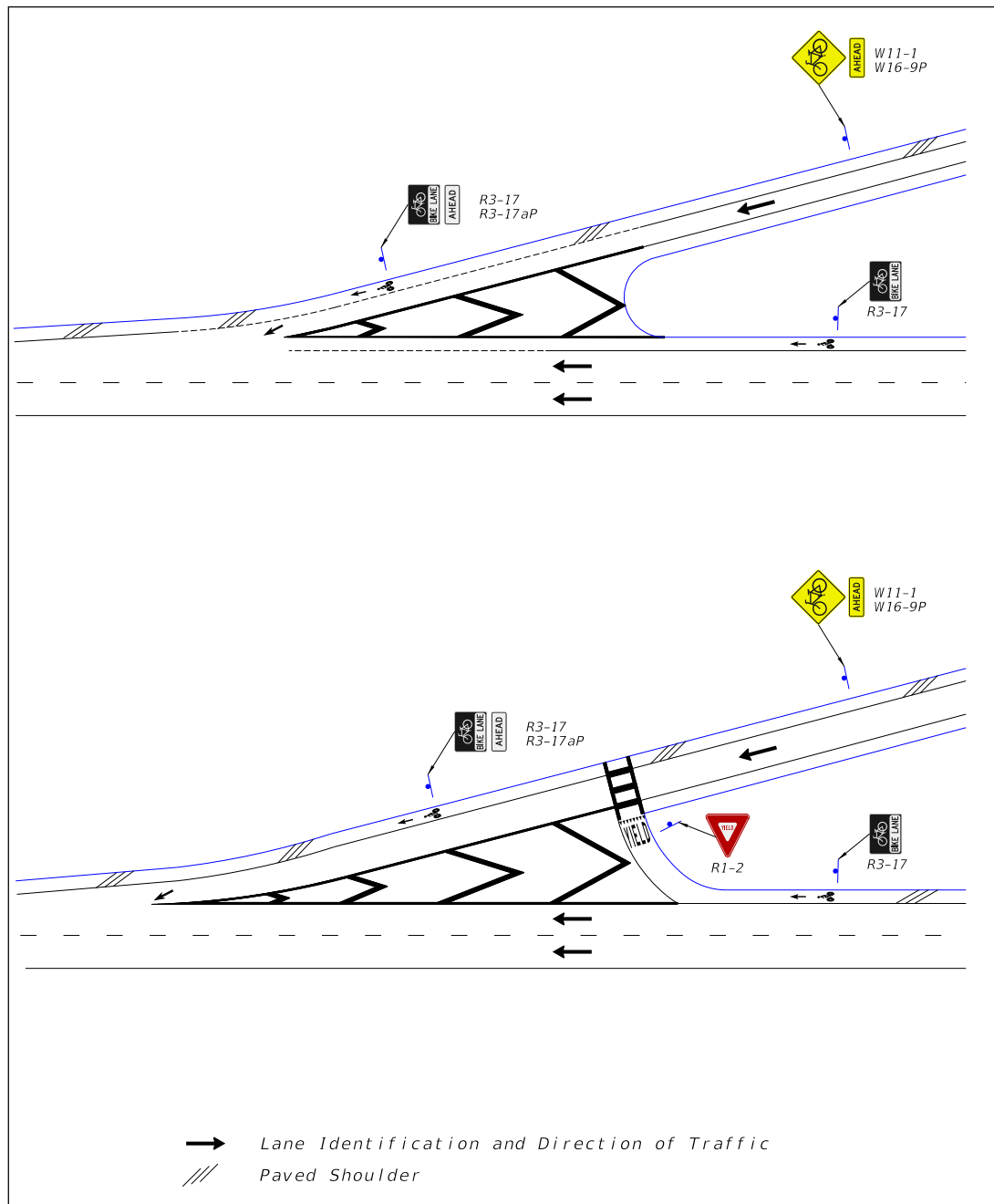




**Figure 9-13 "Tee" Intersection with Bicycle Lanes, Left Turn Lane and Right Turn Drop Lane, Curb and Gutter Typical Section**



**Figure 9-14 Bicycle Lanes on Interchange Ramps,  
Flush Shoulder Typical Section**



## **I REFERENCES FOR INFORMATIONAL PURPOSES**

1. USDOT/FHWA ADA Standards for Accessible Design (ADAAG)  
<http://www.access-board.gov/guidelines-and-standards/buildings-and-sites/about-the-ada-standards/ada-standards>
2. AASHTO – Guide for the Development of Bicycle Facilities, 2012, 4<sup>th</sup> Edition  
<https://bookstore.transportation.org/>
3. NACTO Urban Streets Design Guide  
<http://nacto.org/usdg>
4. FHWA Policy Memo for Flexibility in Pedestrian and Bicycle Facility Design  
[http://www.fhwa.dot.gov/environment/bicycle\\_pedestrian/guidance/design\\_guidance/design\\_flexibility.cfm](http://www.fhwa.dot.gov/environment/bicycle_pedestrian/guidance/design_guidance/design_flexibility.cfm)
5. Storm Drain Handbook, Florida Department of Transportation, October 2014  
<http://www.dot.state.fl.us/rddesign/Drainage/files/StormDrainHB.pdf>
6. Manual on Uniform Traffic Control Devices, May 2012  
[http://mutcd.fhwa.dot.gov/pdfs/2009r1r2/pdf\\_index.htm](http://mutcd.fhwa.dot.gov/pdfs/2009r1r2/pdf_index.htm)

Topic # 625-000-015  
Manual of Uniform Minimum Standards  
for Design, Construction and Maintenance  
for Streets and Highways

~~Draft~~ May - 2015 ~~31~~

~~Revised March February January November 25 26 32 54, 2015 4~~

**THIS PAGE INTENTIONALLY LEFT BLANK**

## CHAPTER 11

### WORK ZONE SAFETY

<u>A</u>	<u>INTRODUCTION</u> .....	<u>11-1</u>
<u>B</u>	<u>BACKGROUND</u> .....	<u>11-1</u>
<u>C</u>	<u>OBJECTIVES</u> .....	<u>11-1</u>
<u>D</u>	<u>POLICY</u> .....	<u>11-2</u>
<u>E</u>	<u>PLANNING OF ROADWORK OPERATIONS</u> .....	<u>11-2</u>
	<u>E.1 Project Requirements</u> .....	<u>11-2</u>
	<u>E.1.a Type of Operation</u> .....	<u>11-2</u>
	<u>E.1.a.1 Routine Operations</u> .....	<u>11-3</u>
	<u>E.1.a.2 Time-Sensitive Operations</u> .....	<u>11-3</u>
	<u>E.1.a.3 Special Operations</u> .....	<u>11-3</u>
	<u>E.1.b Nature of the Roadwork</u> .....	<u>11-3</u>
	<u>E.1.c Nature of the Work Zone</u> .....	<u>11-5</u>
	<u>E.2 Work Scheduling</u> .....	<u>11-5</u>
	<u>E.3 Traffic Control and Protection</u> .....	<u>11-6</u>
	<u>E.4 Coordination with Others</u> .....	<u>11-7</u>
<u>F</u>	<u>WORK ZONE MANAGEMENT</u> .....	<u>11-8</u>
	<u>F.1 Public Information</u> .....	<u>11-8</u>
	<u>F.2 Contracts and Permits</u> .....	<u>11-8</u>
	<u>F.3 Inspection and Supervision</u> .....	<u>11-8</u>
<u>G</u>	<u>EVALUATION OF PROGRAM</u> .....	<u>11-8</u>
<del>A</del>	<del>INTRODUCTION</del> .....	<del>11-1</del>
<del>B</del>	<del>BACKGROUND</del> .....	<del>11-1</del>
<del>C</del>	<del>OBJECTIVES</del> .....	<del>11-1</del>
<del>D</del>	<del>POLICY</del> .....	<del>11-2</del>

E	PLANNING OF OPERATIONS	11-2
E.1	Project Requirements	11-2
E.1.a	Type of Operation	11-2
E.1.a.1	Routine Operations	11-2
E.1.a.2	Traffic Incident Management	11-2
E.1.a.3	Special Operations	11-3
E.1.b	Nature of Work	11-3
E.1.c	Nature of Work Zone	11-4
E.2	Work Scheduling	11-4
E.3	Traffic Control and Protection	11-4
E.4	Coordination with Others	11-5
F	WORK ZONE OPERATIONS	11-6
F.1	Public Information	11-6
F.2	Contracts and Permits	11-6
F.3	Inspection and Supervision	11-6
G	EVALUATION OF PROGRAM	11-6

**THIS PAGE INTENTIONALLY LEFT BLANK**



## CHAPTER 11

### WORK ZONE SAFETY

#### A INTRODUCTION

Construction, maintenance, and utility work, along with traffic incident management are roadwork operations that create ~~operations produce serious~~ highway safety challenges ~~problems~~. The changes ~~to~~ <sup>in</sup> normal traffic flow and the introduction of unexpected travelling conditions at many work zones may generate ~~provide~~ hazardous situations and serious traffic conflicts. A comprehensive plan for work zone safety is required to minimize the risks and effects of these roadwork ~~construction and maintenance~~ operations ~~and management of traffic incidents~~.

#### B BACKGROUND

Section 316.0745, Florida Statutes, mandates the Department of Transportation compile and publish a manual of traffic control devices for use on the streets and highways of the state. To comply with this statute, the Federal Highway Administration's (FHWA) Manual on Uniform Traffic Control Devices (MUTCD) has been adopted for use in Rule 14-15.010, Florida Administrative Code (F.A.C.).

The intent of this chapter is to require conformance to the MUTCD, Part 6.

#### C. OBJECTIVES

Managing traffic during roadwork operations is necessary to complete roadwork or resolve traffic incidents in a timely manner while minimizing traffic delays, maintaining access to travelers, and most importantly maintaining an acceptable level of safety. The general objective of a program of work zone safety is to protect workers, traffic incident responders, pedestrians, bicyclists, and motorists during roadwork ~~construction and maintenance~~ operations. This general objective may be achieved by meeting the following specific objectives:

- Provide adequate advance warning and information about upcoming work zones
- Provide the pedestrians, bicyclists and motorists ~~driver~~ clear information to understand how to navigate through or around the work zone

- Reduce the consequences of an out-of-control vehicle
- Provide safe access and storage for equipment and material
- Promote the speedy completion of projects (including thorough cleanup of the site)
- Promote the use of the appropriate traffic control and protection devices
- Provide safe passageways for pedestrians through, in, and/or around construction or maintenance work zones, including persons with disabilities in compliance with the 2006 Americans with Disabilities Act Standards for Transportation Facilities as required by 49C.F.R 37.41 or 37.43 and the 2012 Florida Accessibility Code as required by 61G20-4.002 ~~accordance with the Americans with Disabilities Act of 1990.~~

## D POLICY

Each ~~highway~~ agency with responsibilities for construction, maintenance, utility, or traffic incident management, or any roadwork operations on streets and highways shall develop and maintain a program of work zone safety, as set forth in the MUTCD, (Chapter 6A). ~~All highway construction projects financed in whole or in part with federal-aid highway funds shall comply with~~ Title 23 Code of Federal Regulations (CFR) 630 Subpart J, more commonly known as the Work Zone Safety and Mobility Rule impose additional requirements for the design and construction of projects financed in whole or in part with federal-aid highway funds.

## E PLANNING OF ROADWORK OPERATIONS

The achievement of work zone safety requires careful and complete planning prior to the initiation of any roadwork ~~project~~. The planning objective is to develop a comprehensive ~~lete operational~~ plan that includes the following considerations:

### E.1 Project Requirements

#### E.1.a Type of Operation

Roadwork operations ~~Construction and maintenance projects~~ may be further classified as routine, time-sensitive ~~traffic incident management~~, or special operations.

### E.1.a.1 Routine Operations

Routine operations would involve projects such as mowing, street cleaning, and preventive maintenance operations conducted on a regularly scheduled basis.

### E.1.a.2 ~~Time-Sensitive Operations~~ ~~Traffic Incident Management~~

~~Time sensitive~~ ~~Traffic Incident Management~~ operations require prompt, efficient action to restore the roadway to a safe condition. These include ~~traffic incident management~~ operations such as clearing ~~vehicle crash or storm or crash~~ debris, ~~addressing~~ hazardous materials spills, repairing or replacing damaged highway safety components and restoring inoperative traffic control devices.

### E.1.a.3 Special Operations

Special operations are defined as ~~the scheduled roadwork~~ ~~these~~ projects, neither routine nor ~~time-sensitive~~ ~~emergency~~ in nature, that are occasionally required to maintain or upgrade a street or highway. These include any construction, maintenance, ~~or utility roadwork, or~~ ~~other~~ operation ~~introducing~~ ~~producing~~ a hazard to workers, bicyclists, pedestrians, or motorists.

Any activity involving encroachment upon the highway right of way by workers, equipment, or material storage and transfer shall be subjected to the requirements of work zone safety.

### E.1.b Nature of ~~the Roadw~~Work

The development of the ~~operation~~ plan for work zone safety should include consideration of the following factors:

- Time span required
- Requirements for continuous operation or occupation of the work zone
- Capability of clearing the site during cessation of work activity

- The various construction methods, equipment, and procedures that may be utilized. Evaluation of alternate methods should be undertaken to determine the safest and most efficient procedures
- The necessity for storing equipment or material in the highway right of way
- Roadwork operations that may expose workers to hazards from through traffic
- Hazards to out of control vehicles such as excavations or unguarded structures or equipment
- ~~• Site conditions that may be confusing or distracting to the driver, pedestrian, or bicyclist, or produce sight distance problems~~
- ~~• Particular problems associated with night safety~~
- Equipment inspection and preventive maintenance program

### E.1.c Nature of the Work Zone

The nature of the work zone and the prevailing traffic conditions should, to a large degree, influence the procedures incorporated into the ~~operation~~ plan for work zone safety. The development of the plan for work zone safety should include consideration of the following factors:

- Location of the work zone in relation to the proximity to side streets, driveways, bus stops, schools, parks, places of worship, etc.
- A ~~D~~etermination of the design vehicle, normal vehicle travelling speeds, and traffic volumes ~~is essential~~.
- ~~The~~ Distribution of traffic with respect to time of day or day of week. ~~(hour, day, etc.) types of traffic, and~~
- Truck percentage, frequency of transit vehicles, and direction of traffic is also important for establishing traffic control procedures.
- Presence of Intelligent Transportation Systems (ITS) such as dynamic message boards.
- Site conditions that may be confusing or distracting to the motorist, pedestrian, or bicyclist.
- Limitations on sight distance.
- Decreased visibility associated with nighttime roadwork operations.
- Impacts of detours and diversions to business community.
- Maintenance of pedestrian accommodation.
- Reasonableness of detour length and complexity.

### E.2 Work Scheduling

Proper work scheduling and sequencing of roadwork operations will not only promote efficiency, but also improve the safety aspects ~~of construction and maintenance operations~~. Where feasible, routine operations and special projects should be conducted during periods of low traffic volume to reduce conflicts. Projects that may be carried out concurrently at the same site should be scheduled simultaneously to eliminate successive disruptions of traffic. Major projects that impede or restrict traffic flow should be coordinated and sequenced with similar projects in adjacent areas, to produce a minimum of disruption to orderly traffic flow in the overall highway network. The scheduling of work at a given location

should include consideration of traffic generation (including special events), as well as traffic restrictions by work activities on the surrounding highway network.

### E.3 Traffic Control and Protection

Plans for traffic control around or through work zones should be developed with safety receiving a high priority. Plans should include protection at work zones when work is in progress and when operations have been halted (such as during the night). Provisions for the protection of work crews, traffic control personnel, bicyclists, pedestrians (in areas of high pedestrian use, construction of temporary facilities should be considered), and motorists shall be included in the operation plans. ~~In all cases, the operation plan for traffic control and protection should include provisions~~ consider provisions for the following:

- Advance warning devices
- Work zone traffic signs
- Clear view of work zone
- Roadway delineation and channeling devices
- Regulatory information
- High visibility safety apparel
- Traffic control officers and law enforcement
- Hazard warning
- Barriers
- Pedestrian and bicyclist safety
- Access for pedestrians, bicyclists, and vehicles
- Access to adjacent properties by the public during construction
- Location of construction vehicles and equipment, including access into and out of the work zone
- Night safety (CHAPTER 6 - ROADWAY LIGHTING)
- Personnel training
- Traffic control and protective devices
- Transit Stops – including passenger access
- Abrupt changes in geometry (lane narrowing, lane drop, transitions)

- Turning restrictions
- Temporary traffic signals

#### **E.4 Coordination with Others**

To ensure safe and efficient construction and maintenance operations, the operation plan should be developed and executed in cooperation with all interested individuals and agencies including the following:

- Highway agencies
- Police agencies
- Emergency agencies
- Contractors
- Utilities
- Building departments
- Mass transit agencies
- Traffic generators
- Local residents and businesses
- Neighboring jurisdictions
- School Boards
- Trash and recycling pick ups

## F WORK ZONE MANAGEMENT OPERATIONS

Roadwork operations ~~Construction and maintenance projects~~ shall follow a coordinated temporary traffic control ~~the operation plan and should include:~~

### F.1 Public Information

All reasonable effort should be made to inform the public of the location, duration, and nature of impending roadwork operations ~~construction of maintenance projects~~. Transit agencies should be given advanced notice of planned operations so they can be responsible for notifying their passengers.

### F.2 Contracts and Permits

For construction and reconstruction projects, the general work zone layout; traffic control and protection procedures; occupational safety and health requirements; and specific traffic control devices required should be incorporated in the contract plans and specifications.

New utility installations in public rights of way are prohibited unless a permit by the appropriate highway agency is issued. Permits for routine maintenance (e.g., deteriorated pole/equipment replacement), minor alterations (e.g., changes in cable, wire, or transformer size), service drops, or emergency work should generally not be required. ~~Any construction by utility companies involving encroachment of the highway right of way by workers, equipment, material storage and transfer, or other hazardous conditions shall be conducted in accordance with the requirements for work zone safety and the~~ Occupational Safety and Health Administration (OSHA) regulations for work zone safety should be reviewed prior to any construction by utility companies involving encroachment of the highway right of way by workers, equipment or material.

### F.3 Inspection and Supervision

A regular program of inspection and supervision of all construction and maintenance projects shall be established and executed.

## G EVALUATION OF PROGRAM

The entire program for work zone safety should be periodically evaluated and revised to provide the safest practicable environment for workers, pedestrians, and motorists during



Topic # 625-000-015  
Manual of Uniform Minimum Standards  
for Design, Construction and Maintenance  
for Streets and Highways

May 2015

Revised March 23, 2015

roadwork construction, utility, and maintenance operations.

## CHAPTER 15

### TRAFFIC CALMING

<u>A</u>	<u>INTRODUCTION</u> .....	<u>15-1</u>
<u>B</u>	<u>PLANNING CRITERIA</u> .....	<u>15-2</u>
<u>C</u>	<u>INAPPROPRIATE TRAFFIC CALMING TREATMENTS</u> .....	<u>15-7</u>
	<u>C.1 Stop Signs</u> .....	<u>15-7</u>
	<u>C.2 Speed Bumps</u> .....	<u>15-7</u>
	<u>C.3 Other Inappropriate Treatments</u> .....	<u>15-7</u>
<u>D</u>	<u>APPROPRIATE TRAFFIC CALMING TREATMENTS</u> .....	<u>15-8</u>
	<u>D.1 Vertical Treatments</u> .....	<u>15-9</u>
	<u>D.2 Horizontal Treatments</u> .....	<u>15-11</u>
	<u>D.3 Neighborhood Entry Control</u> .....	<u>15-14</u>
	<u>D.4 Diverters</u> .....	<u>15-17</u>
	<u>D.5 Other Treatments</u> .....	<u>15-18</u>
<u>E</u>	<u>OTHER SOURCES</u> .....	<u>15-19</u>
<del>A</del>	<del>INTRODUCTION</del> .....	<del>15-1</del>
<del>B</del>	<del>PLANNING CRITERIA</del> .....	<del>15-2</del>
<del>C</del>	<del>INAPPROPRIATE TRAFFIC CALMING TREATMENTS</del> .....	<del>15-6</del>
	<del>C.1 Stop Signs</del> .....	<del>15-6</del>
	<del>C.2 Speed Bumps</del> .....	<del>15-6</del>
	<del>C.3 Other Inappropriate Treatments</del> .....	<del>15-6</del>
<del>D</del>	<del>APPROPRIATE TRAFFIC CALMING TREATMENTS</del> .....	<del>15-7</del>
	<del>D.1 Vertical Treatments</del> .....	<del>15-8</del>
	<del>D.2 Horizontal Treatments</del> .....	<del>15-9</del>
	<del>D.3 Neighborhood Entry Control</del> .....	<del>15-10</del>
	<del>D.4 Diverters</del> .....	<del>15-11</del>
	<del>D.5 Other Treatments</del> .....	<del>15-12</del>

Topic # 625-000-015  
Manual of Uniform Minimum Standards  
for Design, Construction and Maintenance  
for Streets and Highways

~~May~~ 2015~~3~~

~~March~~ ~~November~~ 2019, 2015~~4~~

E OTHER SOURCES ..... 15-13

## TABLES

<u>TABLE 15-1 VERTICAL TREATMENTS .....</u>	<u>15-9</u>
<u>TABLE 15-2 HORIZONTAL TREATMENTS.....</u>	<u>15-11</u>
<u>TABLE 15-3 NEIGHBORHOOD ENTRY CONTROL.....</u>	<u>15-14</u>
<u>TABLE 15-4 DIVERTERS .....</u>	<u>15-17</u>
<u>TABLE 15-5 OTHER TREATMENTS .....</u>	<u>15-18</u>
<del>TABLE 15-1 VERTICAL TREATMENTS .....</del>	<del>15-8</del>
<del>TABLE 15-2 HORIZONTAL TREATMENTS.....</del>	<del>15-9</del>
<del>TABLE 15-3 NEIGHBORHOOD ENTRY CONTROL.....</del>	<del>15-10</del>
<del>TABLE 15-4 DIVERTERS .....</del>	<del>15-11</del>
<del>TABLE 15-5 OTHER TREATMENTS .....</del>	<del>15-12</del>

## FIGURES

<u>FIGURE 9-1 RAISED CROSSWALK.....</u>	<u>15-10</u>
<u>FIGURE 9-2 SPEED HUMP .....</u>	<u>15-10</u>
<u>FIGURE 9-3 CHICANES .....</u>	<u>15-13</u>
<u>FIGURE 9-4 KEY ROUNDABOUT CHARACTERISTICS.....</u>	<u>15-13</u>
<u>FIGURE 9-5 CURB EXTENSION OR BULB OUT .....</u>	<u>15-16</u>
<u>FIGURE 9-6 BICYCLE LANE, ADVANCE YIELD BAR AND CROSSWALK.....</u>	<u>15-18</u>

## CHAPTER 15

### TRAFFIC CALMING

#### A INTRODUCTION

As Florida continues to grow, more and more of the major highways in its communities are becoming congested. This has caused many drivers to seek less crowded local residential streets as alternatives to get to their destinations. In many cases, this has meant the use of local residential streets as bypasses. The increase in traffic intrusion, volume, and speeds on residential streets has degraded the livability standards of various neighborhoods in Florida and as a result many residents complain about their environment (noise, air pollution), livability (quality of life, traffic intrusion, excessive volume, and speed of traffic), safety (as well as safety of their children, pets, and property) and physical characteristics (absence of sidewalks, etc.). This chapter provides some guidance to Florida roadway planners, designers, and traffic engineers on how to address concerns about maintaining or enhancing the quality of life in residential neighborhoods by balancing the need for safety for all roadway users and adjacent property owners of the street network and maintaining the integrity of the highways networks as a whole.

## **B PLANNING CRITERIA**

Traffic calming is the combination of mainly physical measures that reduce the negative effects of motor vehicle use, alter driver behavior, and improve conditions for non-motorized street users.

Communities undertaking a traffic calming program shall have a procedure for planning which neighborhoods and roadways qualify for participation in the program. Specifics of these methods shall be developed by the local jurisdictions. The methods will likely vary from locality to locality. However, some issues should be addressed in all communities:

- Through the public involvement process, adjacent residents and road users who are impacted by the situation should be included in identifying the concern(s).
- The need for traffic-calming measures should be confirmed by appropriate studies (license plate survey, speed, volume, crash analyses) studied.
- Once the concerns are clearly identified and confirmed by traffic studies, and documented, it will provide the focus for possible solution, prioritizing, and development of appropriate traffic calming measures. It will also help determine the best approach to address the concerns.
- When developing traffic calming measures, in addition to the affected property owners, emergency response, transit, school, and sanitation officials and any other entities impacted by the installation of such devices should be included in the review process.

Traffic calming may not be the appropriate method in all cases to address vehicle speeds, volumes, and safety. Alternative solutions or educational tools may be considered.

The application of traffic calming measures should consider possible network and access issues. A system impact analysis should be performed as part of the development process. Vehicular and pedestrian counts, speed data, and crash history of the streets under evaluation should be reviewed. Storm water and environmental impacts also need to be addressed, as well as facility type, urban and rural design factors, and driveway densities.

Design details for each traffic calming measure may vary depending on local conditions. Factors to be considered include both horizontal and vertical deflection, ease of use, emergency vehicle accessibility, ease of maintenance, and facility type. Operational considerations and geometrics are critical factors to consider as well. A list of references and resources to consider in providing more detailed design factors and information can be found at the end of this section. It may be desirable to begin with less restrictive measures and progress to more restrictive ones in stages.

Listed below are some "Do's" and "Don'ts" of the planning process for traffic calming which may be helpful in working through the design process.

### **Do's and Don'ts of the Planning Process**

#### **Do the following:**

- Install temporary traffic calming features and monitor them for a period of time before installing the permanent features. Testing features on site prior to permanent installation will relieve resident anxiety about the impact on their own driving patterns and driving behaviors will adjust to the new route circumstances.
- Have an organized program including public involvement with plans and policies approved and supported by the local government. Emphasize the selected treatments(s) will be initially in a "test" mode, with permanency pending the outcome measurement. Be able to describe what is being done to keep traffic off residential streets.
- Channel public resources by prioritizing traffic calming request according to documentable criteria, setting thresholds of volume, speed, etc., to merit treatment.
- Involve the local service agencies, including fire, police, and emergency medical services personnel, from the start.
- Consult with fire department and EMS personnel to develop the preferred design, particularly with speed humps and traffic circles. Set up traffic circles with cones and have fire trucks and other emergency vehicles drive around them; this will help determine what radius is best for the vehicles used in a given area. The same process can be used in the design of speed humps.

- Review traffic patterns in the neighborhood as a whole. Avoid solving the problem on one neighborhood street by just shifting the traffic to another neighborhood street.



- Make certain that all signing, pavement markings, and channelization is in accordance with the [Manual on Uniform Traffic Control Devices \(MUTCD\)](#), the [AASHTO Policy on Geometric Design of Highways and Streets](#), and [Roundabouts: An Informational Guide, Second Edition, National Cooperative Highway Research Program \(NCHRP 672\)](#) [the Florida Roundabout Guide](#).
- Check sight distances for vehicles, pedestrians, and bicyclists. Sight distance should be consistent with the dimensions shown in CHAPTER 3 – GEOMETRIC DESIGN or CHAPTER 16 – RESIDENTIAL STREET DESIGN.
- Become familiar with the traffic calming features used in other communities and assemble references so that residents can be directed where to see them.
- Decide on a safe design speed beforehand and in consultation with neighborhood residents.
- Check sight distances by visiting the site before and after installation. Do parked cars obstruct sight distances? Do landscaping or other features obstruct sight distance?
- Review the illumination at night. Are additional street lights needed? Does landscaping block the light? Is there a shadow on one side of a median or traffic circle that might hide pedestrians from view?
- Review the channelization during the day and night. Is it a clear approach from all directions? Can it be seen at night? Watch the traffic: Is the driving public confused by the signing and channelization? Make adjustments as needed.
- Review the site for utility conflicts. Is there a fire hydrant? Does it need to be moved? Are there existing utilities in the way?
- Check the storm water drainage. Will the storm drain system need to be moved or revised? Can the runoff flow through or around the device?
- Review on-street parking. Will parked cars block the access of emergency vehicles through or around the proposed neighborhood traffic control devices? Add additional no parking zones where needed. Additional enforcement of parking restrictions may be required to keep the traveled path clear.
- Include weekends in traffic counts, as residential streets may have unique travel patterns and high use periods.

### **Don't do the following:**

- Install neighborhood traffic calming features without a well-engineered program supported by the local government and public.
- Install neighborhood traffic calming features on arterial streets (See Section 1.C.2 for a discussion of roadway classifications). Typically, physical devices are not installed on streets with volumes greater than 3,000 vehicles per day, or with posted or operating speeds of greater than 30 MPH.
- Install neighborhood traffic calming features on streets without curbs unless supplemental features or other design considerations are included to keep vehicles within the traveled way.
- Install neighborhood traffic calming features on street with grades of greater than 10 percent.
- Install neighborhood traffic calming features on major truck routes.
- Install neighborhood traffic calming features on primary emergency routes. Contact local fire, emergency service, and police departments to determine these routes. Secondary access routes should be considered on a case-by-case basis.
- Install neighborhood traffic calming features on curving or winding roads with limited sight distance, unless reduced speed limits and adequate warning signs are used in conjunction with the devices.
- Place neighborhood traffic calming features in front of driveways.
- Neglect to check for conflicting utilities or drainage considerations.
- Install physical features on adjacent parallel routes, unless feasible design alternatives have been agreed upon, as this prevents or hinders emergency response.

## C INAPPROPRIATE TRAFFIC CALMING TREATMENTS

### C.1 Stop Signs

When used for traffic calming, stop signs often do one or more of the following:

- Increase midblock speeds along the street because of drivers trying to make up for lost time
- Increase noise because of quick accelerations and decelerations
- Increase pollution
- Reduce drivers' expectation of a uniform flow
- Relocate the problem
- Cause disrespect for stop signs by drivers and bicyclists

For these reasons, stop signs should not be used for traffic calming.

### C.2 Speed Bumps

Speed bumps shall not be used on public streets. Speed bumps are severe treatments greater than 4 3 to 6 inches high and 1 to 2 feet wide that slow drivers to speeds of less than 10 mph. Due to their abrupt rise and required low speed they can be a hazard to motorists and bicyclists. Speed *humps*, as described in Section D under vertical deflection, should not be confused with speed *bumps*.

### C.3 Other Inappropriate Treatments

There are some other treatments that have been shown to be ineffective at reducing the speed and volume of traffic on local roadways. While a temporary improvement may result, long-term improvement is not likely; consequently, their use is discouraged. These treatments include the following:

- Novelty signs -While signs such as CHILDREN AT PLAY, SENIORS CROSS HERE, SLOW DEAF CHILD, and DEAR CROSSING (meaning loved one) may make an infrequent roadway user aware of a specific local population, most regular users of the roadway are unaffected by the signs.

- Odd speed limit - NEIGHBORHOOD SPEED LIMIT 23 MPH and other odd speed limit signs place a high dependence on police to monitor speeders and are not consistent with the national practice required by the **MUTCD** of posting speeds limits in 5 mph increments.
- Crosswalks – Standard crosswalks marked only with signs and pavement markings do not affect motorists’ speeds and should not be used by themselves as traffic calming treatments.
- **Bicycle** lanes – Standard **bicycle** lanes are not traffic calming treatments. They can be used to provide **additional** space **for bicyclists** between the sidewalk and **travel lanes** ~~motor vehicle traffic~~ but should not be used by themselves for traffic calming.
- Speed trailers – While speed trailers can be used as part of a traffic calming program for educational awareness, they have no lasting effect on motorists’ behavior.
- Reduced speed limit signs – Reduced speed limits without physical traffic calming measures do not slow drivers and should not be used for traffic calming.
- Rumble strips – These applications have high maintenance requirements and can cause severe noise problems. Also, they can be an obstacle to bicyclists.

## D APPROPRIATE TRAFFIC CALMING TREATMENTS

The following sections describe some of the available traffic calming strategies. This list is not exhaustive, nor do the treatments necessarily fall exclusively into only one category.

In a typical traffic calming plan various types of treatments will be used. These plans will be based upon neighborhood preferences combined with engineering judgment.

Design details for traffic calming treatments will vary with application. Specific designs will need to be determined based upon the objective of the installations.

## D.1 Vertical Treatments

Vertical treatments are those that depend upon a change in vertical alignment to cause drivers to slow down. When properly used, these treatments can be effective in reducing speeds and crashes. However, consideration should be given to impacts on emergency responders, buses, and, to some extent, bicyclists and motorcyclists.

Traffic calming features that alter the vertical alignment should not be installed near fire hydrants or mailboxes.

Information on signing and pavement markings for vertical deflections can be found in the [\*Manual on Uniform Traffic Control Devices \(MUTCD\)\*](#).

**TABLE 15-1  
 VERTICAL TREATMENTS**

Treatment	Description	Effect	Concerns	Cost
Raised Intersection	A raised plateau where roads intersect. - Plateau is generally 4 inches above surrounding street.	Slows vehicles entering intersection and improves pedestrian safety.	Increases difficulty of making a turn.	Medium to High
Raised Crosswalk	Raised pedestrian crossing used in mid-block locations. Crosswalks installed on flat-top portion of speed table. <a href="#">See Figure 9.1</a>	Reduces speed and is an effective pedestrian amenity makes pedestrians more visible.	May be a problem for emergency vehicles and vehicles with trailers.	Low to Medium
Speed Humps	Speed humps are parabolic, curved, or sinusoidal in profile, 3 to 4 inches in height and 12 to 14 feet long. Comfortable speeds limited to 15 to 20 mph. <a href="#">See Figure 9.2.</a>	Reduces speed.	May cause delays for emergency vehicles and impact patient comfort. May have greater impacts on longer wheelbase cars.	Low
Speed Tables	Speed tables are flat-topped speed humps, also 3 to 4 inches high but with a sloped approach taper on each side of a flat top. They are generally 20 to 24 feet <a href="#">longwide</a> . Comfortable speed limited to 20 to 25 mph.	Reduces speed.	May cause delays for emergency vehicles and impact patient comfort.	Low

**FIGURE 9-1 RAISED CROSSWALK**



Suwannee Street, Tallahassee, Florida

**FIGURE 9-2 SPEED HUMP**



Inside Loop Road, Orange County, Florida

## D.2 Horizontal Treatments

Horizontal deflection treatments are often more expensive than vertical deflection treatments. However, they have less of an impact on emergency responders and large vehicles with multiple axles. They generally do not create problems for bicyclists and motorcyclists. Because pavement area is usually reduced, additional landscaping may be possible, making horizontal deflection treatments useful as part of neighborhood beautification projects.

Information on striping and signing roundabouts can be found in the *MUTCD*.

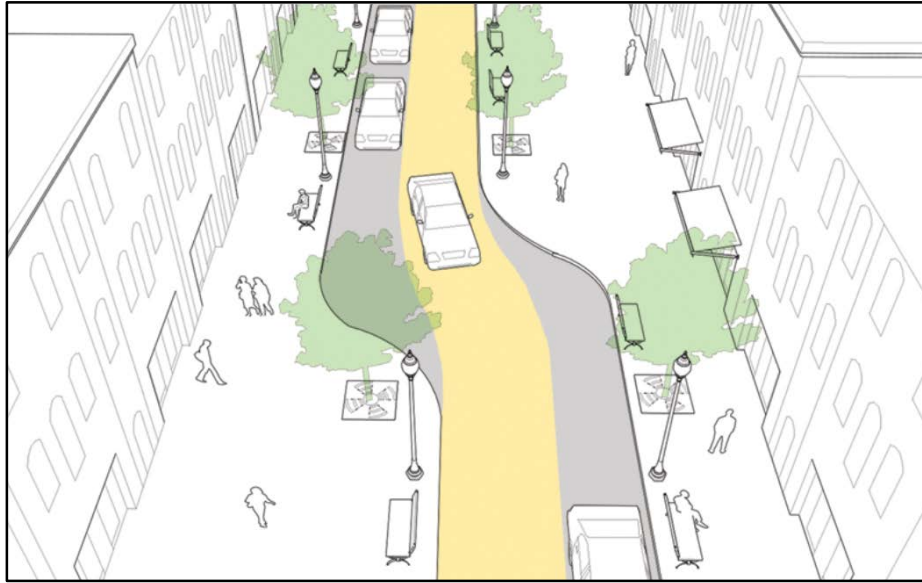
**TABLE 15-2  
 HORIZONTAL TREATMENTS**

Treatment	Description	Effect	Concerns	Cost
Angled Slow Point	Angled deviation to deter the path of travel so that the street is not a straight line	Reduces speed and pedestrian crossing distance.	Landscaping must be controlled to maintain visibility. Conflicts may occur with opposing drivers.	Medium to High
Chicanes	Mainline deviation to deter the path of travel so that the street is not a straight line. <u>See Figure 9.3.</u>	Reduces speed and pedestrian crossing distance.	<u>A chicane design may warrant additional signing and striping to ensure that drivers are aware of a slight bend in the roadway.</u> Increases the area <u>possible for</u> landscaping <u>maintained by residents.</u>	Medium to High
Mini-Circles	A raised circular island in the center of an existing intersection, typically 15 to 20 feet in diameter. May have mountable truck apron to accommodate large vehicles.	Reduces speed and both the number and severity of crashes.	May restrict larger vehicles. May cause some confusion when not signed properly. Some communities have documented increased crashes when mini-circles replaced all-way stop intersections.	Low to Medium
Roundabouts*	<del>A raised circular area placed at intersections with specific design and traffic control features, including yield control of all entering traffic, channelized approaches, geometric curvature; travel is in counter clockwise direction around the circle.</del> May be appropriate at locations <u>as an alternative to</u> , which might otherwise need a traffic signal. <u>See Figure 9.4.</u>	<u>Reduces vehicle speeds and reinforces a change in the driving environment in transition areas</u> <del>Slows traffic and reduces crashes by 50%–90% over stop signs and traffic signals.</del>	<u>May require more space at the intersection itself than other intersection treatments.</u> <del>May restrict larger vehicles. May require significant reconstruction of the intersection and all approaches.</del> <u>While Roundabouts have sometimes been considered traffic calming features, they are primarily traffic control measures.</u>	High

~~\*While Roundabouts have sometimes been considered traffic calming features, they are primarily traffic control measures. Roundabouts are large raised circular areas installed in intersections where a traffic signal might otherwise be needed. All travel is in a counter-clockwise direction. While the main objective of Roundabouts is to control traffic at the intersection, added benefits may include the reduction of vehicular speeds. Some jurisdictions have reported reduction in crashes of 50% to 90% over stop signs and traffic signals. Roundabouts should be designed for design vehicles appropriate for the intersection, and may require significant reconstruction of the intersection and all approaches.~~

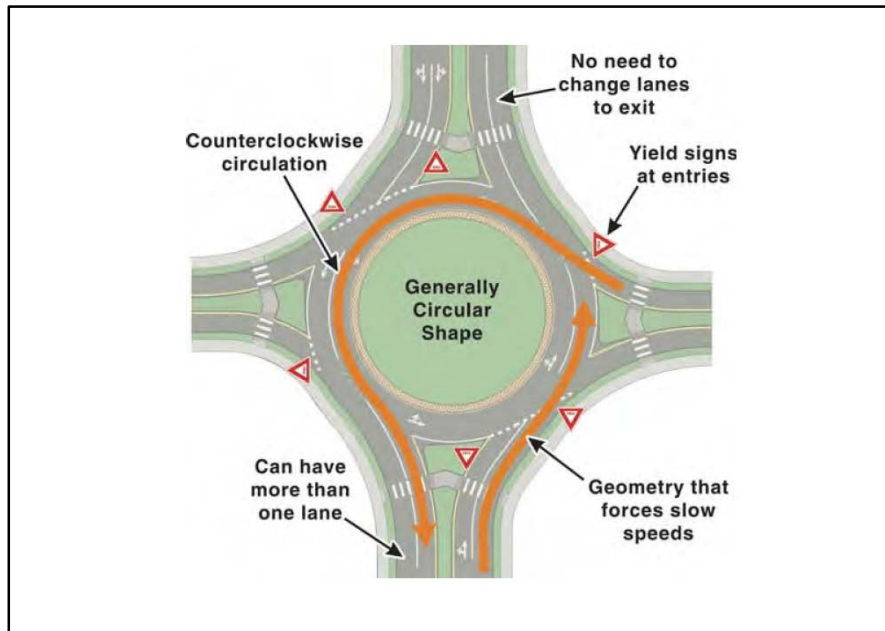


**FIGURE 9-3 CHICANES**



[NACTO Urban Street Design Guide, National Association of City Transportation Officials](#)

**FIGURE 9-4 KEY ROUNDABOUT CHARACTERISTICS**



[NCHRP Report 672: Roundabouts: An Informational Guide, Second Edition](#)

### D.3 Neighborhood Entry Control

Neighborhood entry control treatments include partial street closures and gateway type tools. They are used to reduce speeds and volume at neighborhood access points and may be used in conjunction with neighborhood beautification or enhancement projects and residential area identification.

**TABLE 15-3  
 NEIGHBORHOOD ENTRY CONTROL**

Treatment	Description	Effect	Concerns	Cost
Chokers	Midblock reduction of the street to a single travel lane for both directions.	Reduces speed and volume.	Costs increase if drainage needs to be rebuilt.	Medium to High
Gateway Treatment or Entrance Features	Treatment to a street that includes a sign, banner, landscaping, <u>roadway</u> and <u>roadway</u> narrowing or other structure that helps to communicate a sense of neighborhood identity.	Reduces entry speed and pedestrian crossing distance. Discourages intrusion by cut through vehicles and identifies the area as residential.	Maintenance responsibility. May lose some on street parking.	Medium to High
Curb Extensions or Bulb-outs	<u>Realignment of curb</u> <u>Physical curb reduction at intersection or mid-point of a block to decrease pavement width.</u> <u>of road width at intersection.</u> See Figure 9.5.	<u>Visually and physically narrows the roadway.</u> <u>Discourages cut through traffic and</u> shortens pedestrian crossing distance, <u>increases space for plantings, street furniture.</u>	<u>Need to accommodate cyclists out of street.</u> May impact sight distance, <u>parking, and drainage, and parking may also need to be addressed.</u>	Medium to High
Midblock Median, Slow Point	An island or barrier in the center of a street that separate traffic.	Provides refuge for pedestrians and cyclists.	Landscaping may impede sight distance.	Varies
Lane Narrowing	Street physically narrowed to expand sidewalks and landscaping areas. Could include median, on street parking etc.	Improved pedestrian safety.	May create conflict with opposing drivers in narrow lanes.	Medium to High
One-Way In or One-Way Out Channelization	Intersection reduction of the street to single travel lane with channelization. Also called half road closure.	Reduces speed and traffic.	Costs increase if drainage must be rebuilt. Transfers additional vehicles to other ingress/egress points.	Medium to High
Textured Pavement	A change in pavement texture, and color (e.g., asphalt to brick), that helps make drivers aware of a change in driving	Enhances pedestrian crossings, bike lanes, or on street parking.	Increase maintenance. May increase noise.	Low to Medium

Topic # 625-000-015  
Manual of Uniform Minimum Standards  
for Design, Construction and Maintenance  
for Streets and Highways

~~May 2015~~<sup>3</sup>

~~March November 23 19, 2015~~<sup>4</sup>

---

	environment.			
--	--------------	--	--	--

**FIGURE 9-5 CURB EXTENSION OR BULB OUT**



First and Lee Streets, Ft. Myers, Florida

## D.4 Diverters

A diverter consists of an island or curbed closure, which prevents certain movements at intersections, and reduces speeds and volumes. By diverting motorists within a neighborhood they can significantly reduce cut through traffic.

Diverters must be planned with care because they will impact the people who live in the neighborhood more than anyone else. Trip lengths increase, creating inconvenience to residents. Emergency responders must also be considered when diverting traffic.

Bicyclists and pedestrians should be provided access through traffic diverters.

**TABLE 15-4  
 DIVERTERS**

Treatment	Description	Effect	Concerns	Cost
Diagonal Diverters	Barrier placed diagonally across an intersection, interrupting traffic flow forcing drivers to make turns.	Eliminates through traffic.	May inhibit access by emergency vehicles and residents and increase trip lengths.	Medium
Forced Turn Barrier/Diverters	Small traffic islands installed at intersections to restrict specific turning movements.	Reduces cut through traffic.	Could impact emergency vehicles response time.	Low to Medium
Road Closures, Cul-de-sac	One or more legs of the intersection closed to traffic.	Eliminates through traffic improving safety for all street users.	May increase volumes on other streets in the area. Access restriction may cause concerns for emergency responders. Additional right of way for proper turnaround at dead ends may be required.	Low to Medium
Median Closures	Small median islands installed at cross streets to prevent through movements and restrict left turns.	Reduces cut through traffic.	Could impact emergency vehicle responses, inhibit access, and increase trip lengths or transfer volumes to other streets.	Low to Medium

## D.5 Other Treatments

These treatments are most effective when used in combination with other physical traffic calming features, and should be used as supplements.

**TABLE 15-5  
 OTHER TREATMENTS**

Treatment	Description	Effect	Concerns	Cost
Pavement Markings	Highlighting various area of road to increase driver's awareness of certain conditions such as bike lanes <u>or</u> <u>crosswalks</u> . <u>See Figure 9-6.</u>	Inexpensive and may reduce speed.	May not be as effective as a structure such as curb.	Low
Traversable Barriers	A barrier placed across any portion of a street that is traversable by pedestrians, bicycles, and emergency vehicles but not motor vehicles.	Eliminates cut-through traffic.	Inconvenience to some residents.	Medium
Colored Bike Lanes or Shoulders	A bike lane or shoulder painted, covered with a surface treatment or constructed of a pigmented pavement designed to contrast with the adjacent pavement.	Visually narrows the roadway and may reduce speeds.	May not be effective on roadways with 12 foot lanes.	Low to medium

**FIGURE 9-6 BICYCLE LANE, ADVANCE YIELD BAR AND CROSSWALK**



Franklin Blvd, Tallahassee, Florida

## E OTHER SOURCES

The publications listed below are additional sources, of information related to topics presented in this chapter. Search the Internet Web for up-to-date resources using "traffic+calming" as key words.

1. *Manual on Uniform Traffic Control Devices, with Revisions 1 and 2, May 2012 (MUTCD)*. US Department of Transportation, Federal Highway Administration [http://mutcd.fhwa.dot.gov/kno\\_2009r1r2.htm](http://mutcd.fhwa.dot.gov/kno_2009r1r2.htm)
1. ~~*Civilizing Traffic*, City of Honolulu Traffic Calming Training Manual, Dan Burden, DRAFT.~~
2. *Code of Practice for the Installation of Traffic Control Devices in South Australia*, July 1996/2013. Traffic and Operational Standards Section, Department Transportation, P.O. Box. 1, Walkerville, South Australia, 5081. (updated in 2013)
3. *National Cooperative Highway Research Program (NCHRP) Report 672, Roundabouts: An Informational Guide, Second Edition, (2010)*  
[http://onlinepubs.trb.org/onlinepubs/nchrp\\_rpt\\_672.pdf](http://onlinepubs.trb.org/onlinepubs/nchrp/nchrp_rpt_672.pdf)
- 3.4. The Florida *Intersection Design Guide Roundabout Guide*. Florida Department of Transportation, <http://www.dot.state.fl.us/officeofdesign/publicationslist.shtm> Maps & Publications Sales, Mail Station 12, 605 Suwannee Street, Tallahassee, Florida 32399-0450.
- 4.5. Traffic Calming Measures - Speed Hump, Institute of Transportation Engineers *Guidelines for the Design and Application of Speed Humps*, <http://www.ite.org/traffic/hump.asp> - A Recommended Practice of the Institute of Transportation Engineers, 1997. Institute of Transportation Engineers, 525 School Street, SW, Suite 410, Washington, DC, 20024-2729.
- 5.6. *New York State Supplement (2001) to the Manual of Uniform Traffic Control Devices*, 2009/00. Transportation Planning, Highway Safety, and Traffic Engineering Division, New York State Department of Transportation, 1220 Washington Avenue, Albany, NY 12232-0204.  
<https://www.dot.ny.gov/divisions/operating/oom/transportation-systems/repository/B-2011Supplement-adopted.pdf>
6. ~~*Modern Roundabout Practice in the United States*, National Cooperative Highway Research Program Synthesis off Highway Practice 264, 1998, Jacquernart, G. Transportation Research Board, National Research Council, 2101 Constitution Avenue, NW, Washington, DC, 20418.~~
7. *New York State Vehicle & Traffic Law*, (latest edition). New York State Department

of Motor Vehicles, Swan Street Building, Empire State Plaza, Albany, NY, 12228.

~~8. *Roundabout Design Guidelines, Supplement to the NCHRP 672 (October 2012).* Maryland Department of Transportation, State Highway Administration, P.O. Box 717, Baltimore, MD, 21203-0717. [http://sha.md.gov/OHD2/MDSHA\\_Roundabout\\_Guidelines.pdf](http://sha.md.gov/OHD2/MDSHA_Roundabout_Guidelines.pdf)~~

~~8. \_\_\_\_\_~~

~~9. *Traffic Control Systems Handbook* FHWA-SA-95-032, 1996, Gordon, R.L., R.A. Reiss, H. Haenel, E.R. French, A. Mochaddes, R. Wolcott. Federal Highway Administration, Office of Technology Applications, 400 Seventh Street, SW, Washington, DC 20590. (Updated in 2013) <http://cedb.asce.org/cgi/WWWdisplay.cgi?107985>~~

~~9. \_\_\_\_\_~~

~~10. *Traffic Control Systems Handbook*, Revised Edition, 1985, FHWA-IP-85-1 1, Wilshire, R., R. Black, R. Grachoske, J. Higanbotham. Federal Highway Administration, Office of Implementation, 400 Seventh Street, SW, Washington, DC 20590. (Updated in 2013)~~

~~11. \_\_\_\_\_ *Manual on Uniform Traffic Control Devices, 2000.* US Department of Transportation, Federal Highway Administration, 400 7<sup>th</sup> Street, Washington D.C., 20509.~~

~~12. *Roundabouts: An Informational Guide*, 2000. US Department of Transportation, Federal Highway Administration, 400 7<sup>th</sup> Street, Washington D.C., 20509.~~



## **F REFERENCES –FOR INFORMATIONAL PURPOSES**

The following is a list of the publications that were used in the preparation of this chapter.

- ~~1.~~ 1. *A Guidebook for Residential Traffic Management* WA\RD 368-1, Final Report, December 1994, Savage, J.P. Jr., R.D. MacDonal, J. Ewell. Washington State Department of Transportation, Engineering Publications Room SD3, PO Box 47300, Olympia, WA 98504-7300.
- ~~2.1.~~ 2.1. *Florida Pedestrian Planning and Design Handbook, March 1997, University of North Carolina, Highway Safety Research Center. Florida Department of Transportation, Safety Office, 605 Suwannee Street, Mail Station 82, Tallahassee, Florida 32399-0450.*
- ~~3.2.~~ 3.2. *Highway Design Manual.* Plan Sales Unit, Support Services Bureau, New York State Department of Transportation, 1220 Washington Avenue, Albany, NY, 12232-0204. (updated in 2014)
- ~~4.3.~~ 4.3. ITE Traffic Calming Definition, Lockwood, I.M. In *ITE Journal*, Volume 67, Number 7, July 1997. Institute of Transportation Engineers, 525 School Street, SW, Suite 410, Washington, DC, 20024-2729.
- ~~5.4.~~ 5.4. *Neighborhood Traffic Management and Calming Program*, City of San Buenaventura, Department of Community Services, Engineering Division, 501 Poli Street, Ventura, C.A, 93001.
- ~~6.5.~~ 6.5. Supplementary Pedestrian Crossing channelization Devices. TC Werner memo to Regional Traffic Engineers, July 15, 1997, Transportation Planning, Highway Safety and Traffic Engineering Division, NYS Department of Transportation, 1220 Washington Avenue, Albany, N'Y, 12232.
- ~~7.6.~~ 7.6. *Traffic Calming*, July 1995, Hoyle, C.L., Planning Advisory Service Report Number 456 American Planning Association, Publications Office, 122 S. Michigan Avenue, Suite 1600, Chicago, IL, 60603.
- ~~8.7.~~ 8.7. *Traffic Calming Guidelines*, 1992, Devon County Council, Engineering and Planning Department, Devon County, Great Britain.
- ~~9.8.~~ 9.8. *The Traffic Calming Program: Simplification and Enhancement of the Neighborhood Traffic Management and Arterial Traffic Calming Programs* September 30, 1994. City of Portland, Office of Transportation, Bureau of Traffic Management, Neighborhood Traffic Management, 1120 SW. 5th Avenue, Room 730, Portland, OR, 97204-1914.
- ~~10.9.~~ 10.9. *Traffic Calming: State of Practice*, 1999. FHWA-RD-99-135. R. Ewing. Institute of Transportation Engineers, Washington, D.C.
- ~~11.10.~~ 11.10. *Boulder, Colorado, Neighborhood Traffic Mitigation Program.* Transportation Division oat (303) 441-3266. <http://www.ci.boulder.co.us/publicworks/depts/trans/ntmp/information.htm#Policies>
- ~~12.11.~~ 12.11. *Neighborhood Traffic Management Dade County, Florida's street closure experience*, Anthony J. Castellone and Muhammed M. Hasan, I.T.E. Journal, Volume 68, Number 1.
- ~~13.12.~~ 13.12. *Traffic Flow Modification / Street Closure Procedure.* Miami-Dade County Public Works Department and Metropolitan Planning Organization, Florida.

**THIS PAGE INTENTIONALLY LEFT BLANK**