

**FLORIDA**

BOB MARTINEZ  
GOVERNOR



**DEPARTMENT OF TRANSPORTATION**

605 Suwannee Street, Tallahassee, Florida 32399-0450. Telephone (904) 488-8541 KAYE N. HENDERSON  
SECRETARY

September 12, 1989

TO: DISTRIBUTION LIST  
Manual of Uniform Minimum Standards for Design,  
Construction and Maintenance For Streets and  
Highways (Green Book) - 1989 Edition

Included herewith is a copy (or copies) of the new Green Book. The manual has been completely reprinted to incorporate changes approved by the Advisory Committee. List of changes is given on the following sheet.

In order to ensure that all users of the manual receive future revisions, it will be necessary for those parties receiving a bulk distribution (more than one) to maintain their own record of manual recipients. When revisions are made, you will receive the same number of copies that you received in the initial distribution.

Please insert the new sheets in the Green binders that were distributed 1981. All of the contents of the manual have been superseded.

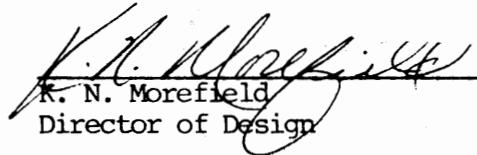
  
R. N. Morefield  
Director of Design

KNM:oj

Attachment

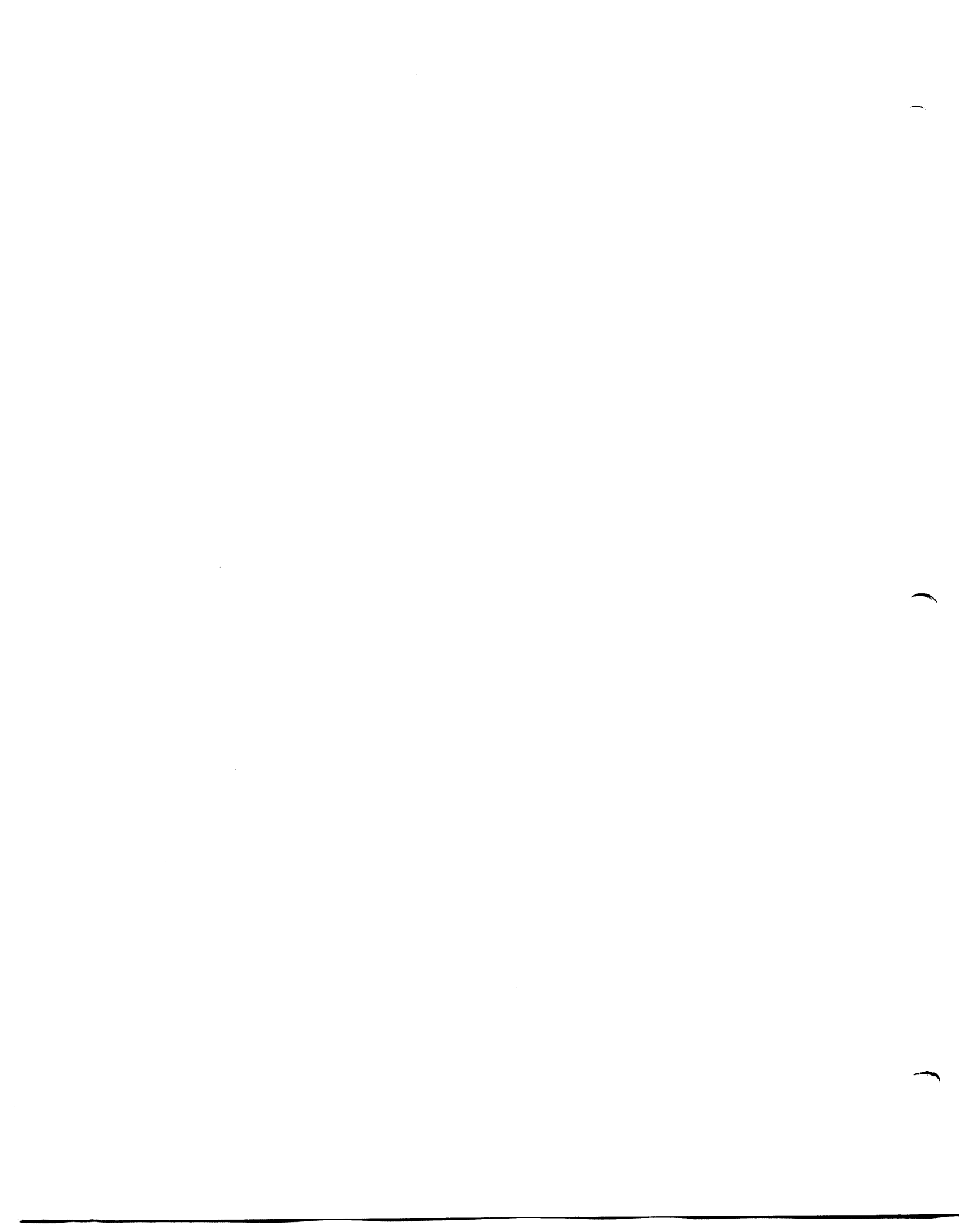

MANUAL OF UNIFORM MINIMUM STANDARDS FOR DESIGN,  
CONSTRUCTION AND MAINTENANCE FOR STREETS AND HIGHWAYS  
STATE OF FLORIDA  
DEVELOPED by  
FLORIDA DEPARTMENT OF TRANSPORTATION  
BEN G. WATTS, INTERIM SECRETARY

ADVISORY COMMITTEE

K. N. Morefield  
Tallahassee  
Chairman

District 1

J. M. Peterson  
Bartow  
Member

J. K. Allison  
Lakeland  
Member

C. E. Cool, Sr.  
Sebring  
Member

B. C. Pratt  
Ft. Myers  
Member

District 4

Frank Gordon  
Ft. Lauderdale  
Member

J. W. Davis  
Vero Beach  
Member

Henry Cook  
Ft. Lauderdale  
Member

Tanzer Kalayci  
Ft. Lauderdale  
Member

District 2

R. G. Greene  
Lake City  
Member

R. L. Hill  
Jacksonville  
Member

E. E. Culpepper  
Gainesville  
Member

D. W. Ditzenberger  
Jacksonville  
Member

District 5

R. H. Cortelyou  
Deland  
Member

Larry Sellers  
Sanford  
Member

R. J. Lawrence  
Daytona Beach  
Member

R. T. Shutts  
Fern Park  
Member

District 3

M. H. Stukey, Jr.  
Chipley  
Member

H. J. Felix  
Pensacola  
Member

D. F. Heinrich  
Crestview  
Member

Chuck Meister  
Pensacola  
Member

District 6

Jerry Norona  
Miami  
Member

W. A. Herndon  
Miami  
Member

Leonard Helmers  
Miami  
Member

E. C. Bechamps  
Miami  
Member

District 7

Larry Gaddy  
Tampa  
Member

J. K. Wicks  
Clearwater  
Member

C. G. Mixon  
Brooksville  
Member

T. F. Lincks  
Tampa  
Member

Florida DOT - Associate Members

Dan E. Burden, State Bicycle Coordinator  
Billy G. Morris, State Safety Engineer

In Accordance with Sections 334.044(10)(a) and 336.045, Florida Statutes.

SEPTEMBER 12, 1989

MANUAL OF UNIFORM MINIMUM STANDARDS  
FOR DESIGN, CONSTRUCTION AND MAINTENANCE  
FOR STREETS AND HIGHWAYS  
1989 EDITION

LIST OF MAJOR CHANGES FOR 1989

1. Typographical errors corrected throughout manual.
2. Advisory Committee membership and Florida Statutes updated.
3. Page 1, Introduction
  - Florida Statute revised from 335.075 to 336.045 and added 334.044(10) (a)
  - Maintenance projects added to third paragraph.
  - Added two sentences to fourth paragraph.
4. Table III-1, Page III-4
  - Added 55 MPH for Rural Arterials (Major) with speed restrictions.
  - Revised 60 MPH to 55 MPH for Rural Arterials (Minor) with speed restrictions.
5. Section III.C.1, Page III-5
  - First sentence on page, "shall" changed to "should".
6. Section III.C.7.d.1), Page III-31
  - Last sentence, first paragraph on page, deleted 45 MPH requirement.
7. Section III.C.7.d.4), Page III-32
  - Fourth paragraph on Page, First sentence replaced "replace" with "reduce".
8. Table III-10, Page III-33
  - Added footnote to 60 foot median width.
9. Table III-12, Page III-36
  - Completely revised
10. Section III.C.7.f, Page III-37
  - Second paragraph on page reworded.
11. Table III-15, Page III-56
  - Added taper footnote.
12. Table III-16, Page III-60
  - Added taper footnote.

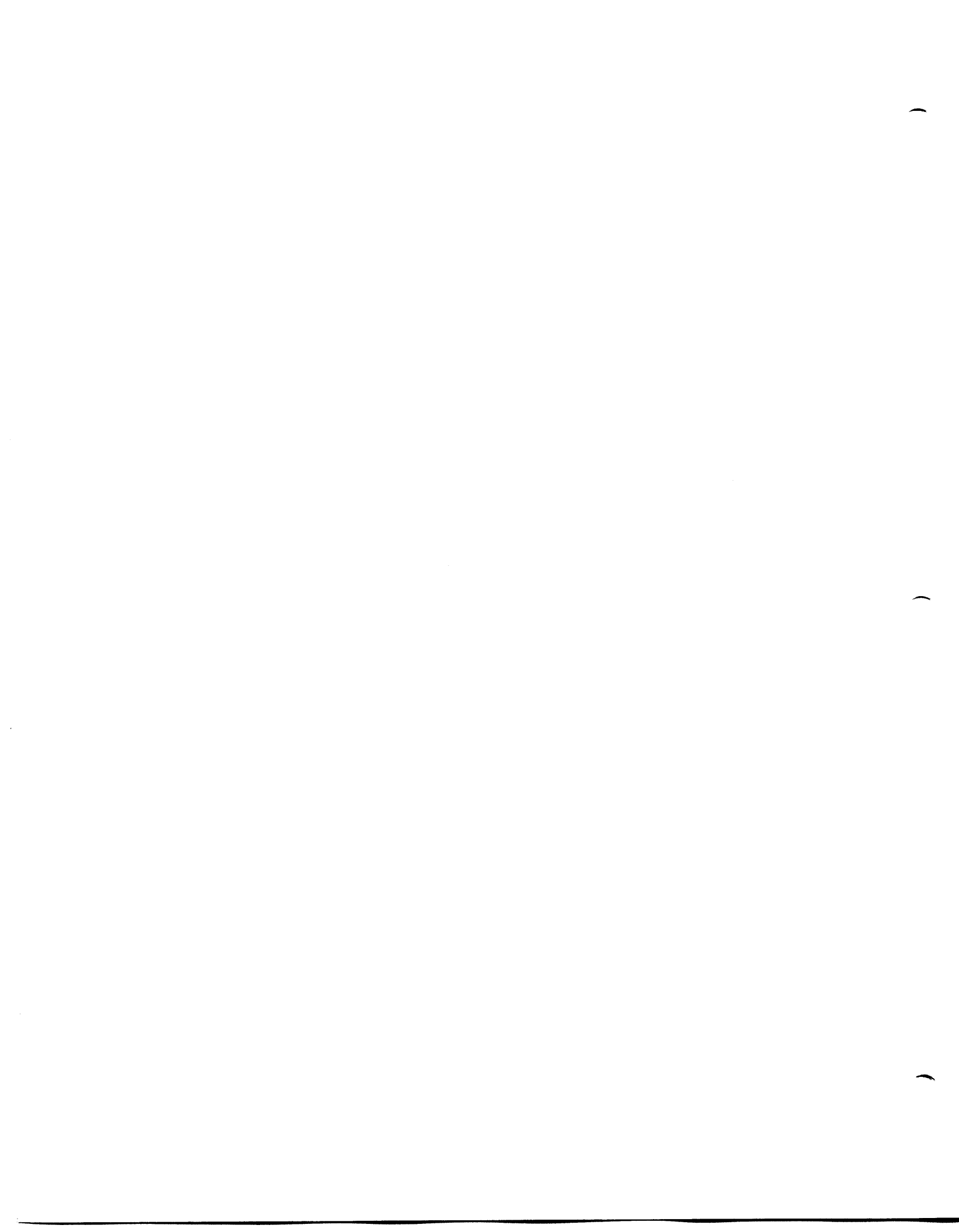

LIST OF MAJOR CHANGES FOR 1989

13. Section III.C.9.h, Page III-71
  - Title of Section changed to "Clear Zone" from "Recovery Area".
  - This term changed throughout manual.
14. Section III.C.10.a, Page III-72
  - Deleted next to last sentence in first paragraph.
15. Section IV.D.12, Page IV-7
  - Changed AASHO to AASHTO and date from 1969 to 1984.
16. Section V.A.3, Page V-2
  - Last sentence of first paragraph, updated manual references.
17. Section V.B, Page V-3 (Formerly V-2)
  - First sentence on page, "shall" changed to "should".
18. Section VII - Rail Highway Grade Crossing
  - Completely rewritten
19. Section VIII.C.3., Page VIII-3
  - Deleted first two paragraphs on page.
20. Section XI.C, Page XI-1
  - Reworded paragraph to update to current maintenance of traffic criteria sources.
21. Section XI.D.3.L, Page XI-4
  - Deleted reference to old FDOT Manual on Traffic Control and Safe Practices.

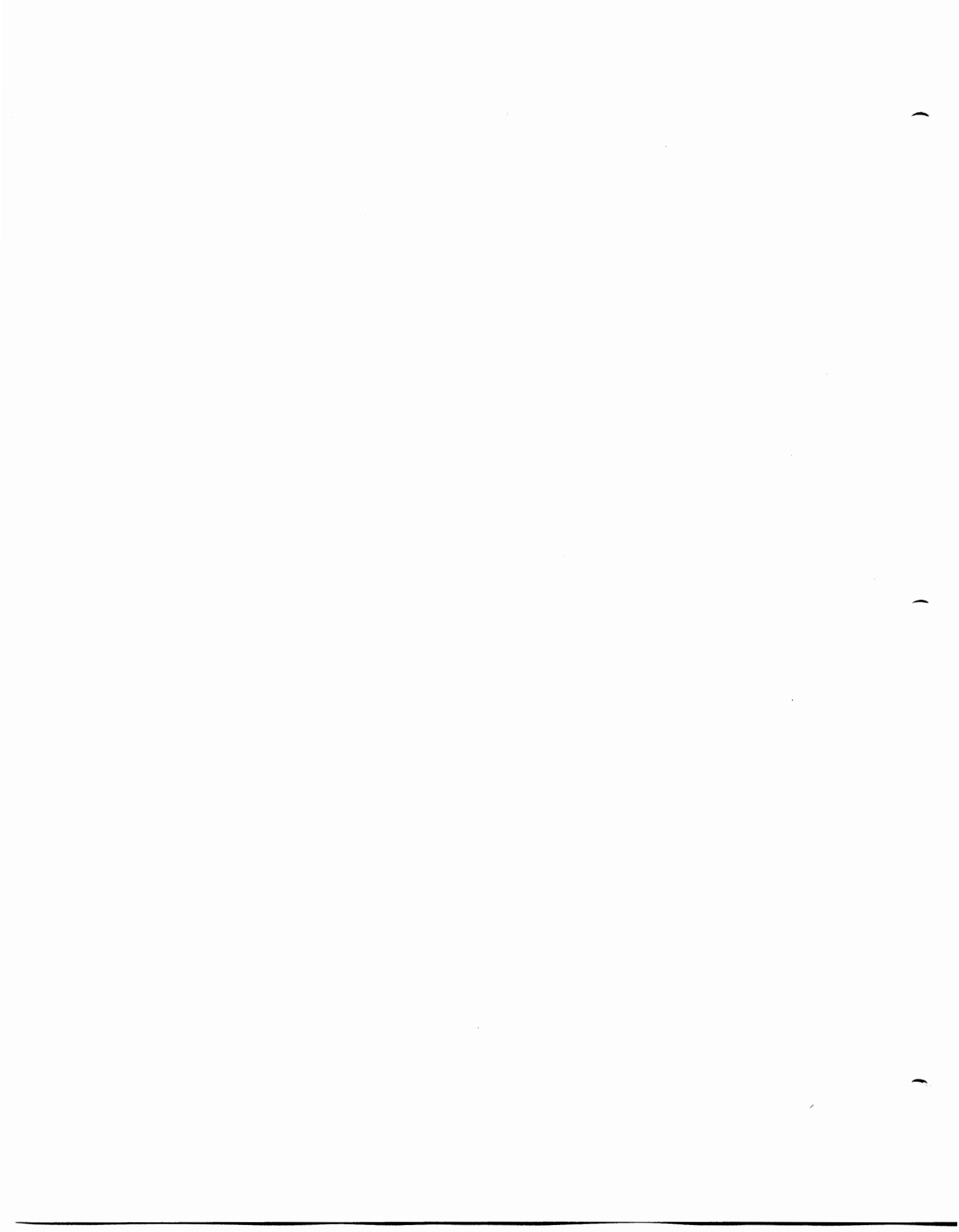



**FLORIDA**

**BOB MARTINEZ**  
GOVERNOR



**DEPARTMENT OF TRANSPORTATION**

605 Suwannee Street, Tallahassee, Florida 32399-0450, Telephone (904) 488-8541 **KAYE N. HENDERSON**  
SECRETARY

September 12, 1989

TO: THE USER OF "THE MANUAL OF UNIFORM MINIMUM STANDARDS"

In order to ensure that you will receive all changes or additions to this manual, please complete the following:

NAME: \_\_\_\_\_

TITLE: \_\_\_\_\_

COMPLETE MAILING ADDRESS:

\_\_\_\_\_  
(FIRM NAME)

\_\_\_\_\_

\_\_\_\_\_

Remove and return this slip to:

DIRECTOR OF DESIGN  
FLORIDA DEPARTMENT OF TRANSPORTATION  
605 SUWANNEE STREET, MAIL STATION 32  
TALLAHASSEE, FL 32399-0450

KNM:oj

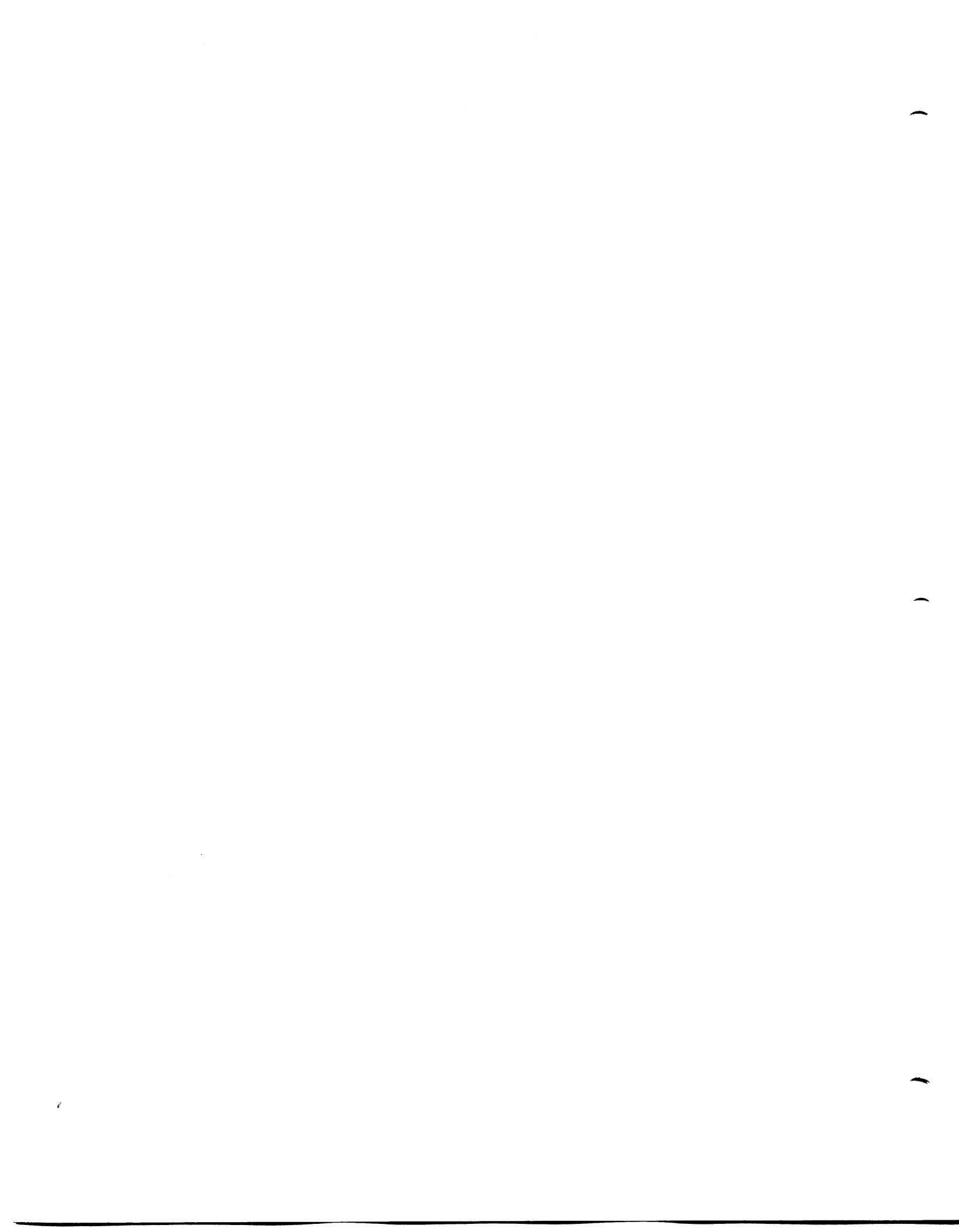

"This publication was produced at an annual cost of \$14,083 or \$5.63 per copy to provide minimum standards and criteria for the design, construction and maintenance of all public streets, roads, highways, bridges, sidewalks, curbs and curb ramps, crosswalks where feasible, bicycle paths, underpasses and overpasses used by the public for vehicular and pedestrian traffic." This statement is printed in compliance with, Section 283.315, Florida Statutes."



TABLE OF CONTENTS

INTRODUCTION.....1

    Policy.....1

    Objectives.....2

    Definition of Terms.....2

SECTION I: PLANNING

A. Introduction.....I- 1

B. Conflicting Criteria.....I- 1

    1. Economic Constraints.....I- 2

    2. Access.....I- 2

    3. Maintenance Capabilities.....I- 2

    4. Utility Operations.....I- 3

    5. Emergency Response for Fire, Police, etc.....I- 3

    6. Environmental Impact.....I- 3

    7. Community and Social Impact.....I- 3

C. Highway Function and Classification.....I- 4

    1. Function.....I- 4

        a. Volume.....I- 4

        b. Vehicle Types.....I- 4

        c. Trip Characteristics.....I- 4

        d. Speed.....I- 4

        e. Safety.....I- 4

        f. Level of Service.....I- 4

        g. Access Requirements.....I- 5

    2. Classification.....I- 5

        a. Basic Classification.....I- 5

            1) Local.....I- 5

            2) Collector.....I- 5

            3) Arterials.....I- 5

        b. Classification Modifications.....I- 5

            1) Urban/Rural.....I- 6

            2) Major/Minor.....I- 6

D. Operation.....I- 6

    1. Policy.....I- 6

    2. Objectives.....I- 6

    3. Activities.....I- 7

a. Maintenance and Reconstruction.....	I- 7
b. Work Site Safety.....	I- 7
c. Traffic Control.....	I- 7
d. Emergency Response.....	I- 8
e. Coordination and Supervision.....	I- 8
f. Inspection and Evaluation.....	I- 8

SECTION II: LAND DEVELOPMENT

A. Introduction.....	II- 1
B. Objectives.....	II- 1
C. Principles and Guidelines.....	II- 2
1. Network Design.....	II- 2
2. Access Control.....	II- 3
3. Land Use Allocation and Restriction.....	II- 4
D. Conflict and Coordination.....	II- 5
E. Control Techniques.....	II- 5
1. Eminent Domain.....	II- 5
2. Police Power.....	II- 6
a. General Regulatory Requirements.....	II- 6
b. Specific Controls.....	II- 6
3. Contracts and Agreements.....	II- 7
4. Education.....	II- 7
F. Reconstruction.....	II- 7

SECTION III: GEOMETRIC DESIGN

A. Introduction.....	III- 1
B. Objectives.....	III- 2
C. Design Elements.....	III- 3
1. Design Speed.....	III- 3
2. Design Vehicles.....	III- 5
3. Sight Distance.....	III- 7
a. Stopping Sight Distance.....	III- 7
b. Passing Sight Distance.....	III- 8
c. Sight Distance at Decision Points.....	III- 8

d.	Intersection Sight Distance.....	III- 9
4.	Horizontal Alinement.....	III- 9
a.	General Criteria.....	III- 9
b.	Superelevation.....	III-10
c.	Curvature.....	III-11
d.	Superelevation Transition.....	III-11
e.	Lane Widening on Curves.....	III-11
5.	Vertical Alinement.....	III-16
a.	General Criteria.....	III-16
b.	Grades.....	III-16
c.	Vertical Curves.....	III-16
6.	Alinement Coordination.....	III-17
7.	Cross Section Elements.....	III-25
a.	Number of Lanes.....	III-25
b.	Pavement.....	III-25
1)	Pavement Width.....	III-25
2)	Pavement Cross Slope.....	III-25
c.	Shoulders.....	III-26
1)	Shoulder Width.....	III-26
2)	Shoulder Cross Slope.....	III-26
d.	Medians.....	III-27
1)	Type of Median.....	III-31
2)	Median Width.....	III-31
3)	Median Slopes.....	III-31
4)	Median Barriers.....	III-32
e.	Roadside Clear Zone.....	III-32
1)	Roadside Clear Zone Width.....	III-35
2)	Roadside Slopes.....	III-35
3)	Criteria for Guardrail.....	III-35
f.	Curbs.....	III-37
g.	Parking.....	III-37
h.	Right-of-Way.....	III-37
i.	Changes in Typical Section.....	III-38
1)	General Criteria.....	III-38
2)	Lane Deletions and Additions.....	III-38
3)	Structures.....	III-38

a)	Horizontal Clearance.....	III-39
b)	Vertical Clearance.....	III-39
c)	End Treatment.....	III-39
8.	Access Control.....	III-39
a.	Justification.....	III-40
b.	General Criteria.....	III-40
1)	Location of Access Points.....	III-40
2)	Spacing of Access Points.....	III-40
3)	Restrictions of Maneuvers.....	III-40
4)	Turn Lanes.....	III-41
5)	Grade Separation.....	III-41
c.	Control for all Limited Access Highways.....	III-41
d.	Control of Urban Streets.....	III-41
e.	Control of Rural Highways.....	III-43
f.	Land Development.....	III-43
9.	Intersection Design.....	III-44
a.	General Criteria.....	III-44
b.	Sight Distance.....	III-45
1)	General Criteria.....	III-45
2)	Obstructions to Sight Distance.....	III-46
3)	Stopping Sight Distance.....	III-47
a)	Approach to Stops.....	III-47
b)	On Turning Roadways.....	III-47
4)	Sight Distance for Intersection Maneuvers (Non-Signalized Intersections).....	III-47
a)	Crossing Maneuver.....	III-47
b)	Left Turn Crossing.....	III-48
c.	Auxiliary Lanes.....	III-58
1)	Merging Maneuvers.....	III-58
2)	Acceleration Lanes.....	III-58
3)	Exit Lanes.....	III-59
a)	Deceleration Lanes.....	III-59
b)	Storage Lanes.....	III-62
d.	Turning Roadways.....	III-62
1)	Design Speed.....	III-62
2)	Horizontal Alinement.....	III-65



	a) Superelevation .....	III-65
	b) Curvature.....	III-65
	c) Superelevation Transitions.....	III-65
	3) Vertical Alinement.....	III-65
	4) Cross Section Elements.....	III-65
	a) Number of Lanes.....	III-65
	b) Travel Lanes.....	III-65
	c) Shoulders.....	III-66
	d) Clear Zones.....	III-66
	e. At-Grade Intersection.....	III-66
	1) Turning Radii.....	III-66
	2) Cross Section Correlation.....	III-67
	3) Median Openings.....	III-67
	4) Channelization.....	III-67
	f. Driveways.....	III-68
	g. Interchanges.....	III-68
	h. Clear Zone .....	III-71
10.	Other Design Factors.....	III-72
	a. Pedestrian and Bicycle Facilities.....	III-72
	b. Utilities.....	III-72
	c. Drainage.....	III-73
	d. Traffic Control Devices.....	III-73
	e. Curb Cut Ramps for the Physically Handicapped.....	III-73
	f. Bridge Design Loadings.....	III-74
	g. Dead-end Streets and Cul-de-sacs.....	III-74
	h. Bus Benches and Transit Shelters.....	III-74
11.	Reconstruction.....	III-74
	a. Introduction.....	III-74
	b. Evaluation of Streets and Highways.....	III-74
	c. Priorities.....	III-75
	1) Obstructions to Sight Distances.....	III-75
	2) Roadside and Median Hazards.....	III-75
	3) Poor Pavement Surfaces.....	III-75
	4) Specific Design Features.....	III-75

SECTION IV: ROADSIDE DESIGN

A. Introduction.....	IV- 1
B. Policy.....	IV- 1
C. Objectives.....	IV- 1
D. Roadside Design.....	IV- 2
1. Geometric Changes.....	IV- 2
a. Horizontal Curves.....	IV- 2
b. Vertical Curves.....	IV- 2
c. Changes in Cross Section.....	IV- 2
d. Decision or Conflict Points.....	IV- 3
2. Fills.....	IV- 3
3. Cuts.....	IV- 3
4. Roadside Canals.....	IV- 3
5. Vegetation.....	IV- 3
a. Stability.....	IV- 4
b. Drainage.....	IV- 4
c. Crash Cushion.....	IV- 4
d. Environmental and Esthetic Considerations.....	IV- 4
6. Drainage.....	IV- 4
a. Inlets.....	IV- 4
b. Ditches.....	IV- 5
c. Culverts.....	IV- 5
7. Curbs.....	IV- 5
a. Barrier Curb.....	IV- 5
b. Drainage Control Curbs.....	IV- 5
8. Poles and Support Structures.....	IV- 6
9. Intersections.....	IV- 6
10. Underpasses.....	IV- 6
11. Bridges and Overpasses.....	IV- 6
12. Mailboxes.....	IV- 7
E. Protective Devices.....	IV- 7
1. Redirection Devices.....	IV- 7
a. Function.....	IV- 7
b. Warranting Conditions.....	IV- 8
c. Location.....	IV- 8
d. Length.....	IV- 8

e. Vehicle Containment.....	IV- 8
f. Barrier Types.....	IV- 8
1) Rigid Barriers.....	IV- 9
2) Flexible Barriers.....	IV- 9
g. Transitions.....	IV- 9
h. Terminations.....	IV- 9
2. Energy Absorbing Devices.....	IV- 9
a. Function.....	IV- 9
b. Warranting Conditions.....	IV-10
c. Design Criteria.....	IV-10
d. Design Details.....	IV-10
3. Breakaway Supports.....	IV-10

SECTION V: PAVEMENT DESIGN, CONSTRUCTION, AND MAINTENANCE

A. Pavement Design.....	V- 1
1. Skid Resistance.....	V- 1
2. Drainage.....	V- 2
3. Structural Integrity.....	V- 2
B. Pavement Construction.....	V- 3
C. Shoulder Treatment.....	V- 3
D. Pavement Maintenance.....	V- 3

SECTION VI: ROADWAY LIGHTING

A. Introduction.....	VI- 1
B. Objectives.....	VI- 1
C. Warranting Conditions.....	VI- 2
1. Criteria Based Upon Accident History.....	VI- 2
2. Criteria Based Upon Analysis and Investigation.....	VI- 2
3. General Criteria.....	VI- 2
D. Level of Illumination.....	VI- 3
E. Uniformity of Illumination.....	VI- 3
F. Underpasses.....	VI- 4
1. Daytime Lighting.....	VI- 4
2. Night Lighting.....	VI- 4

G. Maintenance.....	VI- 4
H. Light Poles.....	VI- 4

SECTION VII: RAIL-HIGHWAY GRADE CROSSINGS

A. Introduction.....	VII- 1
B. Objectives and Priorities.....	VII- 1
1. Conflict Elimination.....	VII- 1
2. Hazard Reduction.....	VII- 1
C. Design of Rail-Highway Grade Crossings.....	VII- 1
1. Sight Distance.....	VII- 2
a. Stopping Sight Distance.....	VII- 2
b. Visibility Triangle.....	VII- 2
c. Crossing Maneuvers.....	VII- 2
2. Approach Alinement.....	VII- 3
a. Horizontal Alinement.....	VII- 3
b. Vertical Alinement.....	VII- 3
3. Highway Cross Sections.....	VII- 4
a. Pavement.....	VII- 4
b. Shoulders.....	VII- 4
c. Medians.....	VII- 4
d. Roadside Clear Zone.....	VII- 4
e. Auxiliary Lanes.....	VII- 4
4. Roadside Design.....	VII- 5
5. Access Control.....	VII- 5
6. Parking.....	VII- 5
7. Traffic Control Devices.....	VII- 5
8. Rail-Highway Grade Crossing Surface.....	VII- 5
9. Roadway Lighting.....	VII- 5
10. Crossing Configuration.....	VII- 6
D. Maintenance and Reconstruction.....	VII- 6

SECTION VIII: PEDESTRIAN TRAFFIC

A. Introduction.....	VIII- 1
B. Policy and Objectives.....	VIII- 1

1.	New Facilities.....	VIII- 1
2.	Existing Facilities.....	VIII- 1
C.	Conflict Elimination and Reduction.....	VIII- 1
1.	General Warrants.....	VIII- 1
2.	Independent Systems.....	VIII- 2
3.	Horizontal Separation.....	VIII- 2
a.	General Criteria.....	VIII- 3
4.	Physical Separation.....	VIII- 3
a.	Longitudinal Barriers.....	VIII- 3
b.	Fencing.....	VIII- 3
5.	Vertical Separation.....	VIII- 4
a.	Overpasses.....	VIII- 4
b.	Underpasses.....	VIII- 4
D.	Protection.....	VIII- 4
1.	Crossings.....	VIII- 4
2.	Controls.....	VIII- 5
3.	Sight Distance.....	VIII- 5
4.	Lighting.....	VIII- 6

SECTION IX: BICYCLE FACILITIES.....IX- 1

SECTION X: MAINTENANCE

A.	Introduction.....	X- 1
B.	Objectives.....	X- 1
C.	Policy.....	X- 1
D.	Identification of Needs.....	X- 2
1.	Inspection.....	X- 2
2.	Accident Records.....	X- 2
E.	Establishment of Priorities.....	X- 2
F.	Establishment of Procedures.....	X- 2
1.	Emergency Maintenance.....	X- 3
2.	Routine Maintenance.....	X- 3
3.	Special Maintenance.....	X- 4
a.	Pavement and Shoulders.....	X- 4

b.	Roadside Clear Zone.....	X- 4
c.	Redirection and Energy Absorbing Devices.....	X- 5
d.	Drainage Facilities.....	X- 5
e.	Roadway Lighting.....	X- 5
f.	Traffic Control Devices.....	X- 5
g.	Rail-Highway Grade Crossings.....	X- 5
h.	Geometric Design Features.....	X- 5
i.	All Highway Safety Features and Components.....	X- 5
G.	Maintenance Program.....	X- 5

SECTION XI: WORK SITE SAFETY

A.	Introduction.....	XI- 1
B.	Objectives.....	XI- 1
C.	Policy.....	XI- 1
D.	Planning of Operations.....	XI- 2
1.	Project Requirements.....	XI- 2
a.	Type of Operation.....	XI- 2
1)	Routine Operations.....	XI- 2
2)	Emergency Operations.....	XI- 2
3)	Special Operations.....	XI- 2
b.	Nature of Work.....	XI- 2
c.	Nature of Work Site.....	XI- 3
2.	Work Scheduling.....	XI- 3
3.	Traffic Control and Protection.....	XI- 3
4.	Coordination with Other Agencies.....	XI- 4
E.	Work Site Operations.....	XI- 5
1.	Public Information.....	XI- 5
2.	Contracts and Permits.....	XI- 5
3.	Inspection and Supervision.....	XI- 5
F.	Evaluation of Program.....	XI- 5

CONVERSION TABLES

To Convert	To	Multiply By
Meters	Centimeters	100.
Meters	Feet	3.2808
Meters	Inches	39.37
Meters	Yards	1.0936
Meters/Second	Miles/Hours	2.237
Miles	Feet	5280.
Miles	Meters	1609.347
Miles	Yards	1760.
Miles/Hour	Feet/Minute	88.
Miles/Hour	Kilometers/Hour	1.609
Ounces	Grams	28.349
Pounds	Grams	453.592
Pounds	Ounces	16.
Pounds/Cubic Foot	Kilograms/Cubic Meter	16.0185
Pounds/Foot	Kilograms/Meter	1.48816
Pounds/Square Foot	Kilograms/Square Meter	4.88241
Pounds/Square Inch	Kilograms/Sq. Centimeter	0.07031
Radians	Degrees	57.30
Rods (Surveyor's Measure)	Meters	5.029
Square Centimeters	Square Inches	0.1550
Square Feet	Square Centimeters	929.0341
Square Inches	Square Centimeters	6.4516
Square Kilometers	Square Miles	0.3861
Square Meters	Square Feet	10.7639
Square Meters	Square Yards	1.1960
Square Yards	Square Meters	0.83613
Tons (Long)	Kilograms	1016.047
Tons (Long)	Pounds	2240.
Tons (Metric)	Pounds	2204.62
Tons (Metric)	Tons (Short)	1.1023
Tons (Short)	Kilograms	907.185
Tons (Short)	Pounds	2000.
Yards	Centimeters	91.44
Yards	Feet	3.
Yards	Meters	0.9144
Acres	Square Meters	4047.
Centimeters	Inches	0.3937
Centimeters	Millimeters	10.
Cubic Centimeters	Cubic Inches	0.0610
Cubic Feet	Liters	28.31625
Cubic Feet	Cubic Meters	0.02832
Cubic Inches	Cubic Centimeters	16.387
Cubic Inches	Liters	0.016387
Cubic Meters	Cubic Feet	35.3145
Cubic Meters	Cubic Yards	1.3079

<u>To Convert</u>	<u>To</u>	<u>Multiply By</u>
Cubic Yards	Cubic Meters	0.76454
Cubic Yards	Liters	764.54
Feet	Centimeters	30.48
Feet	Inches	12.
Feet	Meters	0.3048
Feet/Second	Miles/Hour	0.6818
Grams	Ounces	0.0353
Grams	Pounds	0.0022
Hectares	Acres	2.471
Hectares	Square Meters	10,000
Horsepower (Metric)	Horsepower (U.S.)	0.98632
Horsepower (U.S.)	Horsepower (Metric)	1.01387
Inches	Centimeters	2.54
Kilograms	Grams	1000.
Kilograms	Pounds	2.2046
Kilograms	Tons (Long)	0.00098
Kilograms	Tons (Short)	0.0011
Kilograms/Cubic Meter	Pounds/Cubic Foot	0.062428
Kilograms/Meter	Pounds/Foot	0.671972
Kilograms/Sq. Centimeter	Pounds/Square Inch	14.223
Kilograms/Square Meter	Pounds/Square Foot	0.204817
Kilometers	Meters	1000.
Kilometers	Miles (Statute)	0.6214
Liters	Cubic Centimeters	1000.
Liters	Cubic Inches	61.0250



## INTRODUCTION

The purpose of this Manual is to provide uniform minimum standards and criteria for the design, construction and maintenance of all public streets, roads, highways, bridges, sidewalks, curbs and curb ramps, crosswalks where feasible, bicycle paths, underpasses and overpasses used by the public for vehicular and pedestrian traffic as directed by Sections 334.044(10) (a) and 336.045 Florida Statutes.

These standards are intended to provide the basic guidelines for developing and maintaining a highway system with reasonable operating characteristics and a minimum number of hazards.

The standards established by this Manual are intended for use on all new construction projects. It is understood that the Standards herein cannot be applied completely to all reconstruction and maintenance type projects, however, the Standards should be applied to the extent that economic and environmental considerations and existing development will allow.

When this Manual refers to guidelines and design standards given by current American Association of State Highway and Transportation Officials (formerly AASHO) publications, these guidelines and standards should generally be considered as minimum criteria. The Florida Department of Transportation may have standards and criteria which exceed the minimums presented in this manual or by AASHTO, for streets and highways under its jurisdiction. Department standards, criteria and manuals must be used in conjunction with this manual when preparing projects for the Department.

The criteria and standards set forth in other Manuals which have been included by reference shall be considered as requirements within the authority of this Manual.

### Policy

Specific policies governing the activities of planning, design, construction, reconstruction, maintenance or operation of streets and highways are listed throughout this Manual. All agencies and individuals involved in these activities shall be governed by the following general policies.

- 1) Each public street and highway, and all activities thereon, shall be assigned to the jurisdiction of some highway agency. Each highway agency should establish and maintain a program to promote safety in all activities on streets and highways under its jurisdiction.
- 2) Highway safety shall be considered and given a high priority in order to promote the achievement of the maximum safety benefits for given expenditures and efforts.
- 3) The provision for safe, high-quality streets and highways should take priority over the provision for the maximum highway mileage obtainable for the available funds.

## Objectives

The planning, design, construction, reconstruction, maintenance and operation of streets and highways should be predicated upon meeting the following objectives.

- 1) Develop and maintain a highway system that provides the safest practicable environment for motorists, cyclists, pedestrians and workmen.
- 2) Establish and maintain procedures for construction, maintenance, utility and emergency operations that provide for safe highway operating conditions during these activities.
- 3) Provide streets and highways with operating characteristics that allow for reasonable limitations upon the capabilities of vehicles, drivers, cyclists, pedestrians and workers.
- 4) Provide uniformity and consistency in the design and operation of streets and highways.
- 5) Provide for satisfactory resolution of conflicts between the highway system and social and environmental considerations to aid neighborhood integrity.
- 6) Reconstruct or modify existing facilities to reduce the hazard to the highway users.
- 7) Reduce the deaths, injuries and damage due to highway crashes.

Additional general and specific objectives related to various topics and activities are listed throughout this Manual. Where specific standards or recommendations are not available or applicable, the related objectives shall be utilized as general guidelines.

## Definition of Terms

The following terms shall, for the purpose of this Manual, have the meanings respectively ascribed to them, except in instances where the context clearly indicates a different meaning.

- |        |   |
|--------|---|
| Shall  | - A mandatory condition. Where certain requirements are described with the "shall" stipulation, it is mandatory that these requirements be met. |
| Should | - An advisory condition. Where the "should" is used, it is considered to be advisable usage, recommended but not mandatory.                     |
| May    | - A permissive condition. Where the word "may" is used, it is considered to denote permissive usage.  |
| ADT    | - Average daily two-way volume of traffic.  |

- DHV - Design hourly two-way volume of traffic.
- Highway, Street or Road - A general term denoting a public way for purposes of vehicular traffic, including the entire area within the right of way. The term street is generally used for urban or suburban areas.
- Frontage Road - A street or highway constructed adjacent to a higher classification street or highway for the purpose of serving adjacent property or control of access.
- Roadway - The portion of a street or highway, including shoulders, for the intended use of vehicles.
- Turning Roadway - A connecting roadway for traffic turning between two intersection legs.
- Intersection - The general area where two or more streets or highways join or cross.
- Grade Separation - A crossing of two roadways or a roadway and a railroad or pedestrian pathway at different levels.
- New Construction - The construction of any public road facility (paved or unpaved) where none previously existed, or the act of paving any previously unpaved road, except as provided in Section III-A of these standards.
- Reconstruction - Any road construction other than new construction.
- Traveled Way - The portion of the roadway for the movement of vehicles exclusive of shoulders.
- Right-of-Way - A general term denoting land, property or interest therein, usually in a strip, acquired for or devoted to transportation purposes. More specifically, land in which the State, the Department, a county or a municipality owns the fee or has an easement devoted to or required for use as a public road.
- High Speed - Speeds of 50 mph or greater.
- Design Speed - A speed determined for design and correlation of the physical features of a highway that influence vehicle operation. It is the maximum safe speed that can be maintained over a specified section of highway when conditions are so favorable that the design features of the highway govern.
- Operating Speed - The highest overall speed at which a driver can travel on a given highway under favorable weather conditions and under prevailing traffic conditions without at any

time exceeding the safe speed as determined by the design speed on a section-by-section basis.

Average Running  
Speed

- For all traffic, or component thereof, the summation of distances divided by the summation of running times.

Vehicle

- Every device in, upon, or by which any person or property is or may be transported or drawn upon a travelway, excepting devices used exclusively upon stationary rails or tracks.

Bikeway

- Any road, path, or way which in some manner is specifically designated as being open to bicycle travel, regardless of whether such facilities are designated for the exclusive use of bicycles or are to be shared with other transportation modes.

Wide Curb Lane

- A portion of the roadway which has been designated for shared use by bicycles and motorized traffic, characterized by a curblane which is of such width that bicycle and motorized traffic can be accommodated in the same lane. This lane should always be the through lane closest to the curb (when a curb is provided) or the shoulder edge of the road when a curb is not provided.

Expressway

- A divided arterial highway for through traffic with full or partial control of access and generally with grade separations at major intersections.

Freeway

- An expressway with full control of access.

## SECTION I: PLANNING

### A. Introduction

Planning, as discussed in this section, is not to be confused with the broader transportation systems' planning and project programming which normally precedes the design, construction and maintenance of highways.

All premeditated actions require planning, in the sense that the term is used herein. This type of planning insures that the proper staffs will perform their tasks in a uniform and efficient manner, using the most effective procedures, techniques, materials and equipment to accomplish their assigned function.

The purpose of this manual is to provide the knowledge and guidance necessary to plan and accomplish assignments with a high degree of efficiency.

Developing and maintaining an efficient highway system requires careful planning by each unit in a highway agency. This would include both planning for the design and construction of streets and highways and planning for operating the facilities. Overall planning would include a consideration of all aspects of design, construction and operations (including maintenance) that may affect the resulting characteristics of streets and highways. These characteristics will be significantly affected by the degree to which the various demands and requirements on the highway system are satisfied in the initial planning and design.

Successful highway design requires that the role of each new facility in the overall highway system be clearly delineated. The determination and clear definition of the function and classification of each street and highway is also required. The safety and efficiency of new facilities is predicated, to a large extent, on corridor selection and the provisions for adequate right of way, alinement, and access control. The initial planning and design should also consider provisions for future modifications and upgrading required by changes in speed, volume or standards.

The plans for actually operating a new street or highway should be considered in the initial planning and should be closely coordinated with the design of the facility. The development of plans and procedures for successfully operating the existing highway system must include a consideration of all activities that affect the operating characteristics of each street and highway.

### B. Conflicting Criteria

The development of safe streets and highways should receive the highest priority in the design process. This objective may, however, tend to be compromised by other conflicting requirements and demands upon the highway system. The following criteria should be considered and resolved in

the initial planning and design of streets and highways to avoid a sacrifice of the required safety characteristics.

### 1. Economic Constraints

Economic constraints frequently appear to dictate that a reduction in quality of a given street or highway is necessary. A proper consideration of long-range economic and safety benefits will generally indicate that reduction in quality is undesirable. The philosophy of obtaining maximum highway mileage for the available funds is unsatisfactory from a safety viewpoint and is generally poor economics. The promotion of quality, rather than quantity, generally leads to the best use of highway funds.

The allocation of sufficient funds for obtaining the proper corridor and adequate right of way and alinement should receive the initial priority. Future acquisition of additional right of way and major changes in alinement are often economically prohibitive. This, of course, can result in substandard streets and highways with permanent hazards. Reconstruction or modification under traffic is expensive, as well as inconvenient and hazardous to the motorist. This increase in costs, hazards and inconvenience can be limited by initial development of quality facilities.

In determining the cost/benefit ratio for any proposed facility the economic evaluation should not be confined to the actual expenditure of highway funds and the capacity and efficiency of the facility. The overall costs and benefits of various alternatives should include an evaluation of the probable environmental, community and social impact and their effect upon highway quality and cost. Economic constraints should not be considered as sufficient justification for building low quality, hazardous streets and highways, as human life should be considered in the cost/benefit analysis.

### 2. Access

The demand for access to streets and highways by adjacent property owners can produce problems. Although the public must have reasonable access to the highway network, it is necessary to have certain controls and restrictions. Allowing indiscriminate access can seriously compromise the safety, capacity, and level of service of a street or highway, thus reducing its utility and general economic value.

The proper layout of the highway network and the utilization of effective land use controls (see Section II LAND DEVELOPMENT) can provide the basis for regulating access. The actual access controls should conform to the guidelines given in Section III GEOMETRIC DESIGN.

### 3. Maintenance Capabilities

The planning and design of streets and highways should include provisions for the performance of required maintenance. The planning of the expected maintenance program should be coordinated with the initial

highway design to ensure that maintenance activities may be conducted without excessive traffic conflicts or hazards.

#### 4. Utility Operations

The placement of utilities in the highway right of way should be closely regulated. The planning and design of streets and highways should include guidelines and regulations for any utility activities within the highway right of way. Utility locations that are physical obstructions or create hazardous conditions during maintenance should be avoided.

#### 5. Emergency Response for Fire, Police, etc.

The development of an effective emergency response program is dependent upon the nature of the highway network and the effectiveness of the operation of the system. Provisions for emergency access and communication should be considered in the initial planning and design of all streets and highways.

#### 6. Environmental Impact

The construction and operation of streets and highways frequently produces an adverse effect upon the environment. Early consideration and solution of environmental problems can avoid costly delays and modifications that may compromise the quality and efficiency of operation. Specific problems that are often encountered include the following:

- a. Blockage of light and air.
- b. Noise pollution.
- c. Air and water pollution.
- d. Interruption of the hydrological system.
- e. Degradation of the biological system.

#### 7. Community and Social Impact

The quality and value of a community is directly influenced by the layout and design of streets and highways. The quality of the network determines the freedom and efficiency of movement. Inadequate design of the network and poor land use practices can lead to undesirable community separation and deterioration. The specific design of streets and highways has a large effect upon the overall esthetic value which is important to the motorist and resident.

The preceding problems should not provide the basis for a decision to compromise quality and cost. These conflicting criteria may be resolved through early cooperation and complementation rather than competition. It is the responsibility of the planner and designer to consider and, where possible, to select alternatives that alleviate conflicts and promote positive solutions to these interrelated problems.

## C. Highway Function and Classification

A determination of the function and operational requirements, and a clear definition of the classification of each new facility are required prior to the actual design.

### 1. Function

The design of each new street or highway is based upon its function in the highway system. The operational requirements that must be satisfied to fulfill this function are dependent upon the following factors:

#### a. Volume

The volume of traffic that must be carried by the facility is a primary factor governing the design. Variations in volume with respect to direction and time should also be evaluated to determine the expected requirements for peak capacities.

#### b. Vehicle Type

The types and relative volumes of vehicles expected to use a street or highway influence trip characteristics and design features.

#### c. Trip Characteristics

The function of a new facility is, to a large extent, determined by the length and purpose of vehicle trips. These trip characteristics are influenced by land use characteristics and the highway network layout.

#### d. Speed

The operating speed to be maintained should meet reasonable expectations of the driving public.

#### e. Safety

The provisions of streets and highways with safe operating characteristics shall be considered as a primary requirement.

#### f. Level of Service

The level of service is essentially a measure of the quality of the overall operating characteristics of a street or highway. The factors involved in determining the level of service include speed and safety, as well as travel time, traffic conflicts and interruptions, freedom to maneuver, driving convenience and comfort, and operating costs. The level of service is also dependent upon the actual traffic volume and composition of traffic.



g. Access Requirements

The degree and type of access permitted on a given facility is dependent upon its intended function and should conform to the guidelines given in Section III GEOMETRIC DESIGN. Reasonable access control must be exercised to allow a street or highway to fulfill its function.

2. Classification

Road classifications are defined in Section 334.03 of the Florida Statutes. Functional classification is the assignment of roads into systems according to the character of service they provide in relation to the total road network.

a. Basic Classification

Basic functional categories include arterial, collector, and local roads which may be subdivided into principal, major or minor levels. These levels may be additionally divided into rural and urban categories. This basic classification system is utilized throughout this manual.

1) Local

A route providing service which is of relatively low average traffic volume, short average trip length or minimal through-traffic movements, and high land access for abutting property.

2) Collector

A route providing service which is of relatively moderate average traffic volume, moderately average trip length, and moderately average operating speed. These routes also collect and distribute traffic between local roads or arterial roads and serve as a linkage between land access and mobility needs.

3) Arterial

A route providing service which is relatively continuous and of relatively high traffic volume, long average trip length, high operating speed, and high mobility importance. In addition, all United States numbered highways shall be arterial roads.

b. Classification Modifications

The design and classification of streets and highways should also be based upon a consideration of driver expectations. The function of any facility, as perceived by the driver, essentially determines the driver's willingness to accept restrictions upon speed, capacity, access or level of service.

The basic classification system may also be modified by the following variables.

1) Urban/Rural

In urban areas drivers will generally accept lower speeds and levels of service. Economic constraints in urban areas are also generally more severe. Minor modifications in design criteria are, therefore, appropriate for urban streets.

2) Major/Minor

Streets or highways may be classified as major or minor depending upon the traffic volume, trip length and travel mobility.

D. Operation

The concept of positively operating the existing highway network as a system is essential to promote safety, efficiency and economy. This requires comprehensive planning and coordination of all activities on each street and highway. These activities would include maintenance, construction, utility operations, traffic control, and emergency response operations. Although the behavior of the individual motorist is somewhat independent, driver actions and response, also, can and should be considered as an integral part of the operation of streets and highways. Coordination of the planning and supervision of each activity on each facility is necessary to achieve safety and efficient operation of the total highway system.

1. Policy

Each highway agency with general responsibility for existing streets and highways should establish and maintain an operations department. Each existing street or highway should be assigned to the jurisdiction of the operations department. The operations department shall be responsible for planning, supervision and coordinating all activities that affect the operating characteristics of the highway system under its jurisdiction.

2. Objectives

The primary objective of an operations department shall be to maintain or improve the operating characteristics of the highway system under its jurisdiction. These characteristics include safety, capacity and level of service. The preservation of the function of each facility, which would include access control, is necessary to maintain these characteristics and the overall general value of a street or highway.

### 3. Activities

The achievement of these objectives requires the performance of a variety of coordinated activities by the operations department. The following activities should be considered as minimal for promoting the safe and efficient operation of a highway system.

#### a. Maintenance and Reconstruction

Maintenance or upgrading the quality of existing facilities is an essential factor in preserving desirable operating characteristics. The planning and execution of maintenance and reconstruction activity on existing facilities must be closely coordinated with all other operational activities and, therefore, should be under the general supervision of the operations department.

All maintenance work should be conducted in accordance with the requirements given in Section X MAINTENANCE. The priorities and procedures utilized should be directed towards improvement of the existing system. The standards set forth in this Manual should be used as guidelines for establishing maintenance and reconstruction objectives. All maintenance and reconstruction projects should be planned to minimize traffic conflicts and hazards.

#### b. Work Site Safety

An important responsibility of the operations department is the promotion of work site safety on the existing highway system. The planning and execution of maintenance, construction and other activities shall include provisions for the safety of motorists, pedestrians and workmen. All work shall be conducted in accordance with the requirements presented in Section XI WORK SITE SAFETY.

The work of contractors, utilities and all other persons performing work on the right-of-way should be controlled by the operations department. This not only includes inspections necessary to assure that contractors performing work for the agency comply with contract plans and specifications for safe work procedures, but also that all other persons working on the right-of-way comply with the conditions of their permits and all laws and regulations concerning the safe handling of traffic.

#### c. Traffic Control

Traffic engineering is a vital component of highway operation. The planning and design of traffic control devices should be carried out in conjunction with the overall design of the street or highway. The devices and procedures utilized for traffic control should be predicated upon developing uniformity throughout the system and compatibility with adjacent jurisdictions.

A primary objective to be followed in establishing traffic control procedures is the promotion of safe, orderly traffic flow. The cooperation of police agencies is essential for the achievement of this objective. Traffic control during maintenance, construction, utility or emergency response operations should receive special consideration.

d. Emergency Response

The emergency response activities (e.g., emergency maintenance and traffic control) of the operations department should be closely coordinated with the work of police, fire, ambulance, medical and other emergency response agencies. The provisions for emergency access and communications should be included in the initial planning for these activities.

e. Coordination and Supervision

The coordination and supervision of activities on the highway system should include the following:

1) Supervision and/or coordination of all activities of the operations department and other agencies to promote safe and efficient operation.

2) Coordination of all activities to provide consistency within a given jurisdiction.

3. Coordination with adjacent jurisdictions to develop compatible highway systems.

4. Coordination with other transportation modes to promote overall transportation efficiency.

f. Inspection and Evaluation

The actual operation of streets and highways provides valuable experience and information regarding the effectiveness of various activities. Each operations department should maintain a complete inventory of their highway system and continuously inspect and evaluate the priorities, procedures and techniques utilized in all activities on the existing system under its jurisdiction. Activities by other agencies, as well as the highway agency, should be subjected to this surveillance.

The promotion of highway safety should be aided by including a safety office (or officer) as an integral part of the operations department. The functions of this office would include the identification and inventory of hazardous locations and procedures for improving the safety characteristics of highway operations.

The results of this inspection and evaluation program should be utilized to make the modification necessary to promote safe and efficient operation. Feedback for modifying design criteria should be generated by

this program. The experience and data obtained from operating the system should be utilized as a basis for recommending regulatory changes. The cooperation of legislative and regulatory agencies is essential to develop the regulation of vehicles, driver behavior, utility and emergency response activities, and the access and land use practices necessary for the safe and efficient operation of the highway system.



## SECTION II: LAND DEVELOPMENT

### A. Introduction

A major portion of street and highway construction is generated by land development for residential, commercial and industrial uses. The general land use layout influences, to a large degree, the connections with adjacent highway networks and with different transportation modes. The techniques, principles and general layout used for any development also dictates the resulting internal highway network. The arrangement and space allocation for this network also determines whether safe, efficient and economical streets and highways can be developed.

The existing practices used in land development often do not promote the development of a high quality highway network. Poor development layouts often result in streets and highways with bad alignment, insufficient sight distance and inadequate cross section. Inadequate network design can also lead to unnecessary and undesirable mixing of vehicular and pedestrian traffic. Insufficient space allocations result in cramped, hazardous intersections, narrow roadside clear zones and inadequate room for future modification and expansion. The frequent failure to provide reasonable control of access causes hazardous operating conditions and a dramatic reduction in the capacity and economic value of streets and highways.

Although there are many conflicting demands in land development, the provision of an adequate highway network is essential to preserve the social and economic value of any area. New development controls are needed to aid in the development of safe streets and highways that will retain their efficiency and economic worth. Provisions for adequate alignment, right-of-way, setbacks and access control are essential.

It is recognized that there are many legal and social problems involved in land use controls. The proper coordination and cooperation among the public, various governmental bodies and the highway agencies should, however, allow for the solution of many of these problems. If adequate land development controls are not used, substandard streets and highways will continue to be constructed.

### B. Objectives

The provision for vehicular and pedestrian safety should be an important objective to be considered in land development. Other land development objectives, that are related to highway transportation, should include the promotion of smooth traffic flow, efficiency, economy, esthetics and environmental compatibility of the highway network.

General objectives for land development that should be followed to promote good highway design include the following:

1. Preserve the function of each street and highway (e.g., the use of arterial and collector streets for local circulation seriously compromises their safety and capacity).
2. Provide for smooth, logical traffic flow patterns.
3. Reduce traffic conflicts and confusion to a minimum.
4. Allow for the application of safe geometric design principles (e.g., provide adequate alinement and right-of-way).
5. Provide for bicycle and pedestrian safety.
6. Provide for future modifications and expansion.
7. Provide for environmental compatibility.

### C. Principles and Guidelines

Due to the many variables involved in land development, specific standards and requirements for land use and highway network layout cannot be established. The use of sound principles and guidelines can, however, aid in meeting the objectives of a better highway network. The proper planning and design of the development layout is necessary to provide a satisfactory highway network and to allow for the construction of safe roadways. The following principles and guidelines should be utilized in the design of the highway network, in the control of access and in the land use allocation and restrictions that would affect vehicular and pedestrian use.

#### 1. Network Design

The general layout of the highway network establishes the traffic flow patterns and conflicts; thereby determining the basic safety and efficiency criteria. The design of the highway network should be based upon the following principles:

- a. The layout of street and highway systems should be logical and easily understood by the motorist.
- b. The design and layout of all streets and highways should clearly indicate their function (arterial, collector, etc.).
- c. Local circulation patterns should be compatible with adjacent areas. Arterials and collectors should not be interrupted or substantially altered at development boundary lines.
- d. Flow patterns should be designed to discourage through motorized traffic from using local street networks.



e. Elements in the local circulation should be adequate to avoid the need for extensive traffic controls.

f. The internal circulation should be sufficient to provide reasonable travel distances for local trips.

g. The highway network should be compatible with other transportation modes such as mass transit and pedestrian and bicycle facilities. Conflicts between different modes (particularly with pedestrian and bicycle traffic) should be kept to a minimum.

h. The highway network layout should be designed to reduce internal traffic conflicts. Particular emphasis should be directed towards eliminating substantial speed differentials and hazardous turning and crossing maneuvers. The following principles should be utilized for conflict reduction:

- 1) The number of intersections should be kept to a minimum.
- 2) One-way streets should be used wherever feasible.
- 3) Local streets should be designed (by length, etc.) to limit vehicle speeds.
- 4) The network should be designed to reduce the number of crossing and left turn maneuvers that are required.
- 5) Local street networks should follow a branching pattern with T-intersections. Highly interconnected grid networks are generally more hazardous.

## 2. Access Control

The standards and requirements presented in Section III GEOMETRIC DESIGN, are absolutely necessary to maintain safe and efficient streets and highways. Failure to provide adequate control of access has seriously damaged many existing roadways. Unrestricted access to major collectors and arterials has dramatically reduced their capacity and general economic value. The safety characteristics of these facilities has similarly been diminished by significantly increasing the number of vehicular, pedestrian and bicycle traffic conflicts.

The utilization of proper control over access is one of the most effective and economical means for maintaining the safety and utility of streets and highways. The procedures and controls used for land development significantly affect access control. The following principles should be utilized in the formulation of land use controls for limiting access to streets and highways.

a. The standards presented in Section III GEOMETRIC DESIGN, Access Control should provide the basis for establishing land development criteria for control of access.

b. The use of a street or highway as an integral part of the internal circulation pattern on private property should be prohibited.

c. The intersection of private roads and driveways with public facilities should be strictly controlled.

d. All urban private driveways should be limited to local and minor collector streets.

e. Urban arterials and major collectors should be free from access by driveways and local streets.

f. Commercial strip development, with the associated proliferation of driveways, should be eliminated.

g. The function of all streets and highways should be preserved by the application of the appropriate access controls.

h. The spacing and location of access points should be predicated upon reducing the total traffic conflict.

i. Hazardous maneuvers should be restricted by access controls. For example, crossing and left turn maneuvers may be controlled by continuous median separation.

### 3. Land Use Allocation and Restriction

The provision of adequate space (and the proper location) for various activities is essential to promote safety and efficiency. The following guidelines should be utilized in land use allocation.

a. Major traffic generators (vehicular, pedestrian and bicycle) should be located to provide the minimum conflict with other traffic. These generators should include schools, shopping centers and business establishments.

b. Adequate corridors and space should be considered for utilities. Utility locations should be carefully chosen to minimize interference with the operation of the streets and highways.

c. Adequate space for drainage facilities should be provided. Open ditch drainage facilities should be located well clear of the traveled way.

d. Design for pedestrian and bicycle facilities should comply with SECTIONS VIII and IX of this Manual.

e. Adequate space should be provided for off-street parking. This is essential in commercial and industrial areas.

f. Setback requirements should be adequate to provide ample sight distance at all intersections.

g. Sufficient space should be allocated for the development of spacious and unrestricted intersections.

h. Space allocation for street lighting (existing or planned) should be incorporated into the initial plan. Supports for this lighting should be located outside of the required roadside recovery area unless they are clearly of breakaway type, or are guarded by adequate protective devices.

i. Sufficient right-of-way should be provided for future widening, modification or expansion of the highway network.

j. Adequate corridors for future freeways, arterials or major collectors should be provided.

#### D. Conflict and Coordination

There are many demands that tend to conflict with the development of safe and efficient streets and highways. Meeting the demand for access can frequently destroy the capacity of a roadway. The pressure to limit the amount of land dedicated for streets and highways inhibits the construction of an adequate highway system. Proper coordination between highway agencies and other governmental bodies can, however, assist in improving the procedures used in land development. Cooperation should be solicited from legislative bodies, courts, planning and zoning departments and other governmental agencies to aid in guaranteeing a well designed and adequate highway network. Coordination with developers, engineers, architects, contractors and other private individuals, which is also beneficial, should be a continuous process.

#### E. Control Techniques

The implementation of a sound highway transportation plan requires certain controls. A logical network design, adequate access controls and proper land use allocations are dependent upon proper land development practices. Techniques that may be utilized to establish these necessary controls include the following:

##### 1. Eminent Domain

The purchase of property through the exercise of eminent domain is one of the most effective means for land use control. The acquisition of sufficient right-of-way is essential to allow for the construction of adequate streets and highways as specified in Section III GEOMETRIC DESIGN and Section IV ROADSIDE DESIGN. The provision of adequate space for clear roadsides, sight distance, drainage facilities, buffer zones, frontage roads and future expansion is also necessary to develop and maintain safe

streets and highways. Legislation enabling the purchase of land for all of the preceding requirements should be solicited.

## 2. Police Power

The regulatory authority of state and local highway agencies (and other related agencies) should be sufficient to implement the necessary land use controls. The necessary legislation to provide this authority should be solicited by all highway agencies. The following general regulatory requirements and specific areas of control should be considered as minimum.

### a. General Regulatory Requirements

Regulatory authority should include the following:

- 1) General highway transportation plans should be enforceable.
- 2) Enforcement allocation of highway corridors for future expansions is absolutely essential.
- 3) Precise development plot plans that clearly show all highway layouts, pedestrian and bicycle facilities and utility corridors should be required. The execution of these plot plans should be enforceable.
- 4) Building permits and zoning should require approvals by appropriate highway agency.
- 5) A safety check of proposed streets and highways should be a required step in the review and acceptance of all development plans.
- 6) The necessary elements for achieving these highway goals should be incorporated into all land use and zoning ordinances.

### b. Specific Control

Specific areas of control that are necessary to develop adequate and efficient roadways may include the following:

- 1) Land use allocation.
- 2) Control of access.
- 3) Driveway design.
- 4) Street and highway layout.
- 5) Location of vehicular and pedestrian generators.
- 6) Location of pedestrian and bicycle facilities.

7) Setback requirements for sight distances and clear roadsides.

### 3. Contracts and Agreements

Where land purchase or regulatory authority is not available or appropriate, the use of contractual arrangements or agreements with individuals can be beneficial. Negotiations with developers, builders and private individuals should be used, where appropriate, to aid in the implementation of the necessary controls.

### 4. Education

Education of the public, developers and governmental bodies can be beneficial in promoting proper land developmental controls. The need for land allocation, access control and design standards should be clearly and continuously emphasized. Successful solidification of the cooperation of the public and other governmental bodies depends upon clear presentation of the necessity for reasonable land development controls.

### F. Reconstruction

The implementation of sound land development controls can, of course, be extremely beneficial in reconstruction activity.



## SECTION III: GEOMETRIC DESIGN

### A. Introduction

Geometric design is defined as the design or proportioning of the visible elements of the street or highway. The geometry of the roadway is of central importance since it provides the framework for the design of other highway elements. In addition, the geometric design establishes the basic nature and quality of the vehicle path which has a primary effect upon the overall safety characteristics of the street or highway.

In order to achieve a total design which is consistent and safe, the design of roadway geometry must be conducted in close coordination with the other design elements. These other elements would include: pavement design, roadway lighting, traffic control devices, drainage and structural design. The design should consider safe roadside clear zones, pedestrian safety, emergency response and maintenance capabilities.

The safety characteristics of the design should be given primary consideration. The initial establishment of sufficient right-of-way and adequate horizontal and vertical alignment is not only essential from a safety standpoint but also necessary to allow future upgrading and expansion without exorbitant expenditure of highway funds.

The design elements selected should be reasonably uniform but should not be rigid and inflexible.

The minimum standards presented in this section should not automatically become the standards for geometric design. The designer should continuously use his initiative and ability to provide a consistent design of superior safety characteristics. Reconstruction and maintenance of existing facilities should, where feasible, be directed towards meeting these standards.

Because of the relatively low traffic volumes and the extensive mileage, design standards for local roads and streets are of a comparatively low order as a matter of practicality. In restricted or unusual conditions, it may not be possible to meet the minimum standards. However, every effort should be made to obtain the best possible alignment, grade, sight distance and proper drainage that are consistent with the terrain, the development, safety and fund availability.

The design features of urban local streets are governed by practical limitations to a greater extent than those of similar roads in rural areas. The two dominant design controls are: 1) The type and extent from urban development and its limitations on rights-of-way, and 2) zoning or regulatory restrictions. Some streets primarily are land service streets in residential areas. In such cases, the overriding consideration is to foster a safe and pleasing environment. Other streets are land service only in part, and features of traffic service may be predominant.

The selection of the type and exact design details of a particular roadway or highway requires considerable study and thought. When reference is made to guidelines and design details given by current AASHTO publications, these guidelines and standards should generally be considered as minimum criteria. For the design of recreational roads, local service roads and alleys, see AASHTO publications.

Right-of-way and pavement width requirements for new construction may be reduced for the paving of certain existing unpaved subdivision streets and low volume rural roads provided all of the conditions listed below are satisfied.

1. The road is functionally classified as a local road.
2. The 20 year projected ADT is less than 750 vehicles per day and 20 year projected peak hourly volume is 100 vehicles per hour or less.
3. The road has no foreseeable probability of changing to a higher functional classification through changes in land use, extensions to serve new developing land areas, or any other use which would generate daily or hourly traffic volumes greater than those listed above.
4. There is no reasonable possibility of acquiring additional right-of-way without:
  - a. Incurring expenditures of public funds in an amount which would be excessive compared to the public benefits achieved.
  - b. Causing substantial damage or disruption to abutting property improvements to a degree that is unacceptable considering the local environment.

#### B. Objectives

The major objective in geometric design is to establish a vehicle path and environment that provides a reasonable margin of safety for the motorist, bicyclist (and pedestrian) under the expected operating conditions and speed. The achievement of this objective may be realized by meeting certain specific objectives, which include the following:

1. Provide the simplest geometry attainable, consistent with the physical constraints.
2. Provide a design that has a reasonable and consistent margin of safety at the expected operating speed.
3. Provide a design that is safe at night and under adverse weather conditions.



4. Provide a facility that is adequate for the expected traffic conditions.
5. Allow for reasonable deficiencies in the driver, such as:
  - a. Periodic inattention
  - b. Reduced skill and judgment
  - c. Slow reaction and response
6. Provide a hazard-free environment that is "forgiving" to a vehicle that has badly deviated from the travel path or is out of control.

### C. Design Elements

#### 1. Design Speed

The design speed is defined as the maximum safe speed that can be maintained over a given section of highway when weather, light and traffic conditions are such that the design features of the highway govern. The basic purpose in using the design speed concept is to achieve consistency in the various design elements that influence vehicle operations. Since many critical design features (e.g. sight distance and curvature) are predicated upon design speed, the selection of the proper value is essential to allow for the safe design of a street or highway.

The selection of an appropriate design speed is dependent upon the predicted driver behavior and is, therefore, rather complex. This selection of design speed should receive considerable preliminary investigation and thought so that safety will be realized from the design.

The primary basis for selecting the design speed should be a rational prediction of the probable maximum operating speed (by approximately 90 percent of the vehicles) on the street or highway. The "average running speed" is not acceptable as a design speed.

Recommended minimum values for design speed are given in Table III-1. These values should, however, be considered as general guidelines only. The maximum normal operating speed is dependent upon many variables including: the topography, the general roadway geometry, the surrounding land use, the degree of access, the frequency of traffic signals or other traffic control devices, the posted speed limit and the degree of enforcement. The driver does not necessarily adjust his speed to the classification or importance (or lack of) of the street or highway.

TABLE III-1  
RECOMMENDED MINIMUM DESIGN SPEED, MPH

TYPE OF ROADWAY	URBAN		RURAL	
	*SPEED RESTRICTIONS		*SPEED RESTRICTIONS	
	WITH	WITHOUT	WITH	WITHOUT
Freeway or Expressway	50	60		70
Arterial (Major)	40	55	55	70
Arterial (Minor)	35	50	55	70
Collector(Major)	35	45	50	65
Collector(Minor)	30	40	40	60
Local**	20	30	30	50

\*Speed restrictions are features of the design which would effectively limit the operating speed, such as:

- a. A short length or roadway (e.g., a dead-end street).
- b. Closely spaced stop signs, traffic signals or other control devices.
- c. Locations that would by nature of the surrounding development or land use, indicate to the driver that lower speeds were necessary.

\*\*Design speeds lower than 30 mph may be used for local, subdivision type roads and streets. Streets with a design speed less than 30 mph shall be posted with appropriate legal speed limit signs.

The design speed should not be less than the expected posted or legal speed limit. A design speed 5 to 10 mph greater than the posted speed limit will compensate for a slight (and generally not enforceable) overrunning of the speed limit by many drivers.

The use of the higher design speed (no speed restrictions) given in Table III-1 is recommended for the following situations:

1. Topography that would allow or encourage higher operating speeds.
2. Roadway geometry that permits high speeds.
3. Long uninterrupted sections of roadway.

The design speed utilized should be consistent over a given section of highway. Required changes in design speed should be effected in a gradual fashion. When isolated reductions in design speed cannot reasonably be avoided, appropriate speed signs should be posted.

## 2. Design Vehicles

A "design vehicle" is a selected motor vehicle whose weight, dimensions and operating characteristics are used to establish highway design controls to accommodate vehicles of a designated type. For the purpose of geometric design, the design vehicle should be one with dimensions and minimum turning radii larger than those of almost all vehicles in its class. Design vehicles are listed in Table III-2. One or more of these vehicles should be used as a control in the selection of geometric design elements. In certain industrial (or other) areas, special service vehicles may have to be considered in the design. Fire equipment and emergency vehicles should have reasonable access to all areas.

If a significant number or percentage (5 percent of all the total traffic) of vehicles of those classes larger than passenger vehicles are likely to use a particular street or highway, that class should be used as a design control. The design of major arterial streets and highways should normally be adequate to accommodate all design vehicles. The decision as to which of the design vehicles (or other special vehicles) should be used as a control is complex and requires careful study. Each situation must be evaluated individually to arrive at a reasonable estimate of the type and volume of expected traffic.

Design criteria that are significantly affected by the type of vehicle include: horizontal and vertical clearances, alignments, lane widening on curves, shoulder width requirements, turning roadway and intersection radii, intersection sight distance and acceleration criteria. Particular care should be taken in establishing the radii at intersections so that vehicles may enter the street or highway without encroaching upon adjacent travel lanes or leaving the pavement.

TABLE III-2  
DESIGN VEHICLES

DESIGN VEHICLE		DIMENSIONS IN FEET					
TYPE	SYMBOL	WHEELBASE	OVERHANG		Overall Length	Overall Width	Height
			Front	Rear			
Passenger Car	P	11	3	5	19	7	4.25
Single Unit Truck	SU	20	4	6	30	8.5	13.5
Single Unit Bus	BUS	25	7	8	40	8.5	13.5
Articulated Bus	A-BUS	18+24 =42	8.5	9.5	60	8.5	10.5
Motor Home	MH	20	4	6	30	8	-
Car & Camper Trailer	P/T	11+5+ 18=34**	3	10	49	8	-
Car & Boat Trailer	P/B	11+5+ 15=31**	3	8	42	8	-
Semi-trailer Combination, Intermediate	WB-40	13+27 =40	4	6	50	8.5	13.5
Semi-trailer Combination, Large	WB-50	20+30 =50	3	2	55	8.5	13.5
Semi-trailer Full trailer Combination	WB-60	9.7+20 +9.4*+20.9 =60	2	3	65	8.5	13.5

\*Distance between rear wheels of front trailer and front wheels of rear trailer.

\*\*Distance between rear wheels of trailer and front wheels of car.

### 3. Sight Distance

The provision for adequate horizontal and vertical sight distance is an essential factor in the development of a safe street or highway. An unobstructed view of the upcoming roadway is necessary to allow time and space for the safe execution of passing, stopping, intersection movements and other normal and emergency maneuvers. It is also important to provide as great a sight distance as possible to allow the driver time to plan for future actions. The driver is continuously required to execute normal slowing, turning and acceleration maneuvers. If he can plan in advance for these actions, traffic flow will be smoother and less hazardous. Unexpected emergency maneuvers will also be less hazardous if they are not combined with uncertainty regarding the required normal maneuvers. The appropriate use of lighting (see Section VI ROADWAY LIGHTING) may be required to provide adequate sight distances for night driving.

Future obstruction to sight distance that may develop (e.g., vegetation) or be constructed should be taken into consideration in the initial design. Areas outside of the highway right-of-way that are not under the highway agency's jurisdiction should be considered as points of obstruction. Planned future construction of median barriers, guardrails, grade separations or other structures should also be considered as possible sight obstructions.

#### a. Stopping Sight Distance

Safe stopping sight distance shall be provided continuously on all streets and highways. The factors which determine the minimum distance required to stop include: the vehicle speed, the driver's total reaction time, the characteristics and conditions of the vehicle, the friction capabilities between the tires and the roadway surface, and the vertical and horizontal alignment of the roadway. It is desirable that the driver be given sufficient sight distance to avoid an object or slow moving vehicle with a natural, smooth maneuver rather than an extreme or panic reaction.

The determination of available stopping sight distance shall be based upon a height of the driver's eye equal to 3.50 feet and a height of obstruction to be avoided equal to 0.50 feet. It would, of course, be desirable to use a height of obstruction equal to zero (coincident with the roadway surface) to provide the driver with a more positive sight condition. Where horizontal sight distance may be obstructed on curves, the driver's eye and the obstruction shall be assumed to be located at the centerline of the travel lane on the inside of the curve.

The stopping sight distance shall be no less than the values given in Table III-6.

b. Passing Sight Distance

The passing maneuver, which requires occupation of the opposing travel lane, is inherently dangerous. The driver is required to make simultaneous estimates of time, distance, relative speeds and vehicle capabilities. Errors in these estimates result in frequent and serious accidents.

Highways with two or more travel lanes in a given direction are not subject to requirements for safe passing sight distance. Two-lane, two-way highways should be provided with safe passing sight distance for as much of the highway as feasible. The driver demand for passing opportunity is high and serious limitations on the opportunity for passing reduces the capacity and safe characteristics of the highway.

The distance traveled after the driver's final decision to pass (while encroaching into the opposite travel path) is that which is required to pass and return to the original travel lane in front of the overtaken vehicle. In addition to this distance, the safe passing sight distance must include the distance traveled by an opposing vehicle during this time period, as well as, a reasonable margin of safety. Due to the many variations in vehicle characteristics and driver behavior, the passing sight distance should be as long as is practicable.

The determination of passing sight distance shall be based upon a height of eye equal to 3.50 feet and a height of object equal to 4.25 feet. Where horizontal sight distance may be obstructed on curves, the driver's eye and object shall be assumed to be located at the centerline of the travel lane on the inside of the curve. Where passing is permitted, the passing sight distance shall be no less than the values given in Table III-6

c. Sight Distance at Decision Points

It is desirable to provide sight distances exceeding the minimum at changes in geometry, approaches to intersections, entrances and exits, and other potential decision points or hazards. The sight distance should be adequate to allow the driver sufficient time to observe the upcoming situation, make the proper decision and take the appropriate action in a normal manner.

Minimum stopping sight distance does not provide sufficient space or time for the driver to make decisions regarding complex situations that require more than a simple perception-reaction process. In many cases, rapid stopping or lane changing may be extremely undesirable and cause hazardous maneuvers (e.g., in heavy traffic conditions); therefore, it would be preferable to provide sufficient sight distance to allow for a more gradual reaction.

The sight distance on a freeway preceding the approach nose of an exit ramp should exceed the minimum by 25 percent or more. A minimum

sight distance of 1000 feet, measured from the drivers eye to the road surface is a desirable goal. There should be a clear view of the exit terminal including the exit nose.

d. Intersection Sight Distance

Sight distances for intersection movements are given in the general intersection requirements.

4. Horizontal Alinement

a. General Criteria

1. The standard of alinement selected for a particular section of highway should extend throughout the section with no sudden changes from easy to sharp curvature. Where sharper curvature is unavoidable, a sequence of curves of increasing degree should be utilized.

2. Winding alinement consisting of sharp curves is hazardous, reduces capacity and should be avoided.

3. The use of the maximum degree of curvature permitted for a given design speed should be avoided wherever possible. The use of flatter curves is not only less hazardous but also frequently less costly due to the shortened roadway.

4. Maximum curvature should not be used at the following locations:

a) On high fills or elevated structures. The lack of surrounding objects reduces the driver's perception of the roadway alinement.

b) At or near a crest in grade.

c) At or near the low point in a sag or grade.

d) At the end of long tangents.

e) At or near intersections or points of access or egress.

f) At or near decision points.

5. The "broken back" arrangement of curves (short tangent between two curves in the same direction) should be avoided. This arrangement produces an unexpected and hazardous situation.

6. When reversals in alinement are used a sufficient length of tangent between the reverse curves is required for adequate superelevation transition.

7. Compound curves should be avoided, especially when curves are sharp. They tend to produce erratic and dangerous vehicle operation. When compound curves are necessary the radius of the flatter curve should not be more than 50% greater than the sharper curve.

8. The transition between tangents and curves should normally be accomplished by the use of appropriate straight line transitions or spirals. This is essential to assist the driver in maintaining his vehicle in the proper travel path.

9. For small deflection angles, curves should be suitably lengthened to avoid the distracting appearance of a kink. Curves should be at least 900 feet long for a central angle of 1 degree or 500 feet long for a central angle of 5 degrees.

10. Gently flowing alignment is generally more pleasing in appearance, as well as superior from a safety standpoint.

#### b. Superelevation

In the design of highway curves it is necessary to establish a proper relationship between curvature of the roadway and design speed. The use of superelevation (rotation of the roadway about its axis) is employed to counteract centrifugal force and allow drivers to comfortably and safely travel through curves at the design speed.

The superelevation rates for rural highways are shown on Figure III-1. These rates are based on a maximum superelevation rate of 0.10 foot per foot of roadway width. Additional superelevation details are given on Florida Department of Transportation Index drawings.

The superelevation rates recommended for municipal highways are shown on Figure III-2. These rates are based on a maximum superelevation rate of .05 foot per foot of roadway width and are recommended for major streets in built up areas. For urban freeways and high speed urban arterials in new locations, maximum superelevation rates from .06 to .10 foot per foot are recommended (see AASHTO "A Policy on Geometric Design of Highways and Streets - 1984"). Additional superelevation details for municipal highways are given on Florida Department of Transportation Index drawings.

Although superelevation is advantageous for traffic operations, various factors often combine to make its use impractical in many built-up areas. Such factors include wide pavement areas, need to meet grade of adjacent property, surface drainage considerations, and frequency of cross streets, alleys, and driveways. Therefore, horizontal curves on lower-speed streets in subdivision and urban areas are usually designed without superelevation, only side friction being used to counteract the centrifugal force. Figure III-2 may be used for the determination of the maximum safe speed for horizontal curves on lower-speed urban streets.



c. Curvature

Where a directional change in alinement is required, every effort should be made to utilize the smallest degree (largest radius) curve possible. The use of the maximum degree of curvature should be avoided when possible. Design speed maximum degree of curve relationships are given in Table III-3. The use of sharper curvature for the design speeds shown in Table III-3 would call for superelevation beyond the limit considered practical or for operation with tire friction beyond safe or comfortable limits or both. The maximum degree of curvature is a significant value in alinement design.

d. Superelevation Transition (Superelevation runoffs plus tangent runout)

Superelevation runoff is the general term denoting the length of highway needed to accomplish the change in cross slope from a section with the adverse crown removed to the fully superelevated section, or vice versa. Tangent runout is the general term denoting the length of highway needed to accomplish the change in cross slope from a normal cross section to a section with the adverse crown removed, or vice versa. The use of spiral curves is encouraged to transition from the tangent to the curve. Where the spiral curve is employed, its length is used to make the superelevation runoff.

Florida Department of Transportation Index drawings show in detail superelevation transitions for various sections and methods for determining the length of transition.

e. Lane Widening on Curves

The travel lane should be widened on sharp curves due to the increased difficulty for the driver to follow the proper path. Trucks experience additional difficulty due to the fact that the rear wheels may track considerably inside the front wheels thus requiring additional width. Required lane widths for mainline and turning roadways are given in AASHTO. ("A Policy on Geometric Design of Highways and Streets - 1984"). A transition length shall be introduced in changing to an increased/dedreased lane width. This transition length shall be proportional to the increase/decrease in pavement width in a ratio of not less than 50' of transition length for each foot of change in lane width.

Figure III-1  
RURAL HIGHWAYS

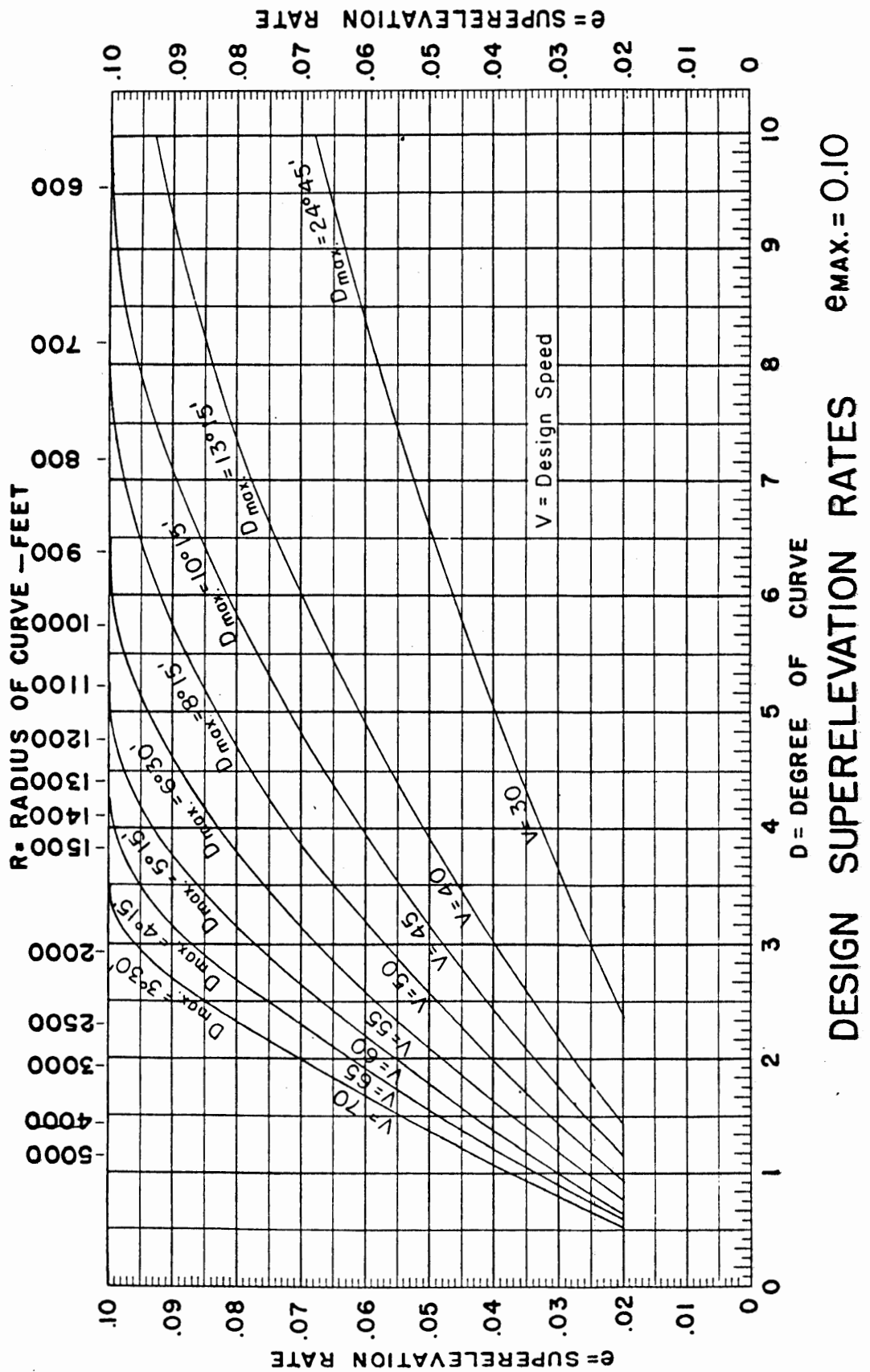

DESIGN SUPERELEVATION RATES  $e_{MAX.} = 0.10$

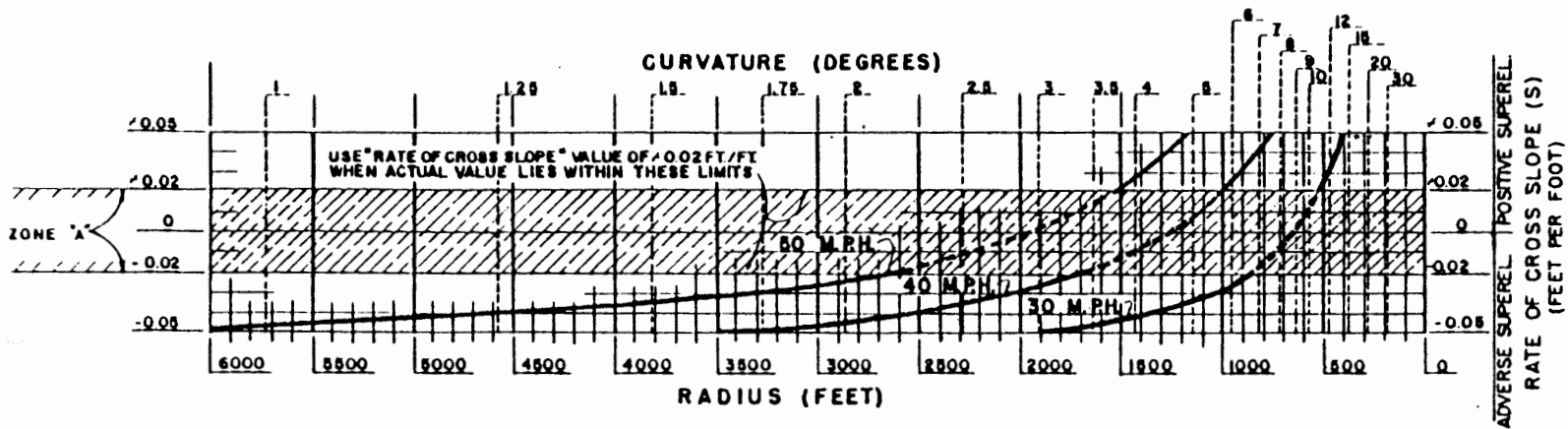
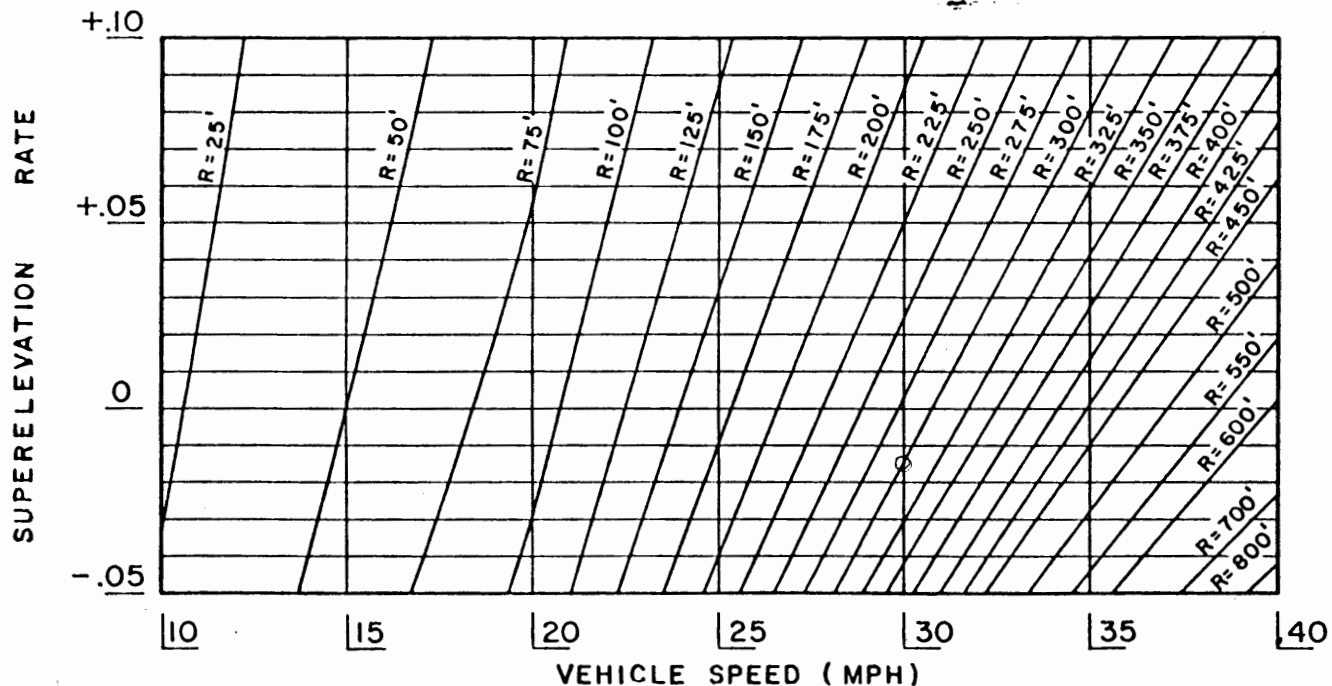

CHART SHOWING REMOVAL OF CROWN AND/OR SUPERELEVATION NECESSARY FOR CURVATURE AT VARIOUS DESIGN SPEEDS ON MAJOR STREETS

NOTE: WHEN THE ACTUAL SUPERELEVATION VALUE LIES WITHIN ZONE "A", USE A POSITIVE RATE OF 0.02 FT./FT.



MAXIMUM SAFE SPEED FOR HORIZONTAL CURVES ON LOWER SPEED URBAN STREETS

III - 13

FIGURE III-2

**TABLE III-3.**  
HORIZONTAL CURVATURE

MAXIMUM CURVATURE, DEGREES			
Rural (Based on max superelevation of 0.10 ft. per ft.)		Urban (Based on max superelevation of 0.05 ft. per ft.)	
Design Speed	Max Degree Of Curve	Design Speed	Max Degree Of Curve
30	24°45' (230' Radius)	30	14°
40	13°15'	35	10°
50	8°15'	40	7°30'
60	5°15'	45	6°
65	4°15'	50	5°
70	3°30'		
Rural Interstate                      3 Deg. Max (2 Deg. Desirable Maximum)			
MINIMUM RADIUS, FEET			
Urban - Lower Speed Streets			
Design Speed	Min Radius With .05 ft. Per Ft. Superelevation	Min Radius Without Superelevation	
15	40	50	
20	75	95	
25	140	180	
30	225	300	

LATERAL CLEARANCE FROM EDGE OF PAVEMENT TO OBSTRUCTION  
BASED ON LINE OF SIGHT ON CURVED ROADWAYS  
(REF: FIGURE III-2A)

Design Speed, mph	30	40	50	60	65	70
MAXIMUM CURVATURE, DEGREES	24.75	13.25	8.25	5.25	4.25	3.5
REQUIRED LATERAL CLEARANCE (M-7'), FEET						
For Lower Stopping S.D.	15	16	23	25	22	24
For Upper Stopping S.D.	15	25	34	42	43	49
½ MAX. CURVATURE, DEGREES	12.38	6.62	4.12	2.62	2.12	1.75
REQUIRED LATERAL CLEARANCE (M-7'), FEET						
For Lower Stopping S.D.	5	5	8	10	9	9
For Upper Stopping S.D.	5	9	14	18	20	22

Figure III-2A

RELATION BETWEEN DEGREE OF CURVE AND VALUE OF MIDDLE ORDINATE NECESSARY TO PROVIDE STOPPING SIGHT DISTANCE ON HORIZONTAL CURVES UNDER OPEN ROAD CONDITIONS.

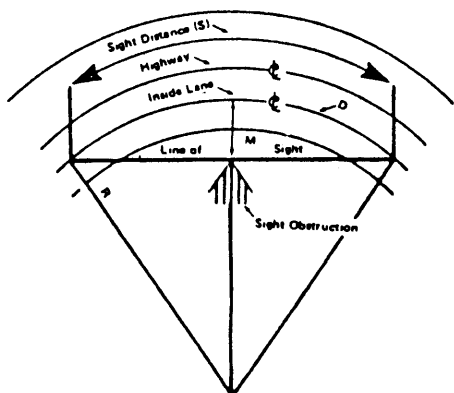

where  
 $S$  = Stopping Sight Distance (FT)  
 $D$  = Degree of Curve  
 $M$  = Middle Ordinate (FT)  
 $R$  = Radius (FT)

$$M = \frac{5730}{D} \left(1 - \cos \frac{SD}{200}\right)$$

$$R = \frac{5730}{D} \text{ and } \theta = \frac{SD}{200}$$

$$M = R \left(1 - \cos \theta\right)$$

$$R = R \left(1 - \cos \frac{28.65 S^2}{R}\right)$$

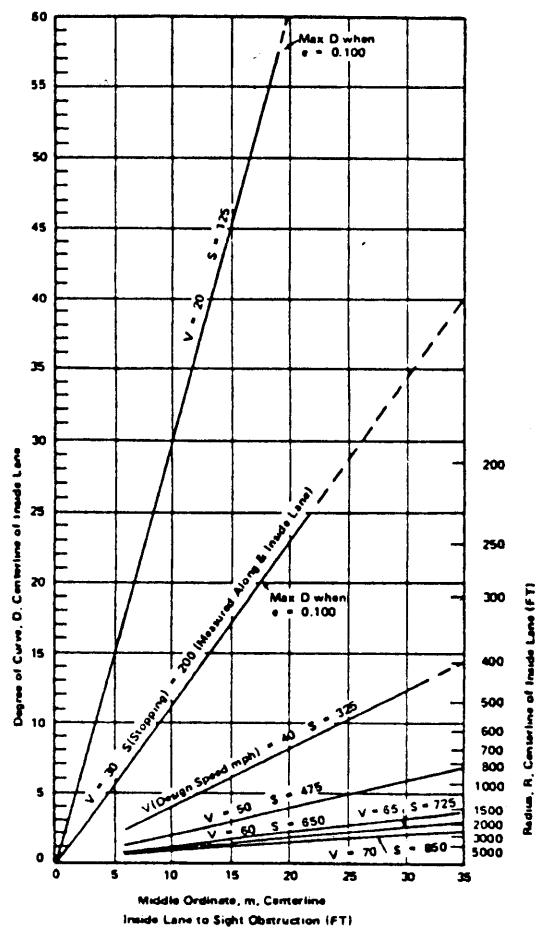
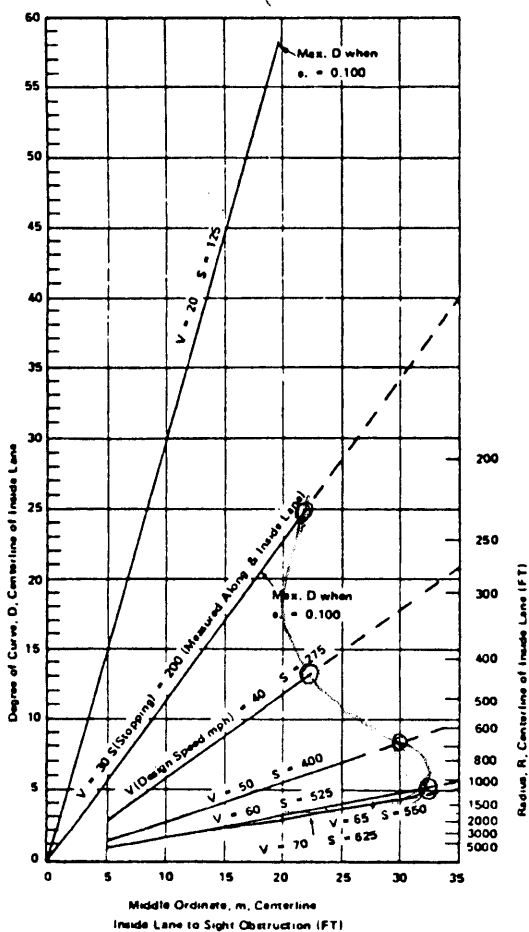

RANGE OF LOWER VALUES

RANGE OF UPPER VALUES

## 5. Vertical Alinement

### a. General Criteria

1. The selection of vertical alinement should be predicated to a large extent upon the following criteria:

a) Obtaining maximum sight distances.

b) Limiting speed differences (particularly for trucks) by reducing magnitude and length of grades.

2. A "hidden dip" which would not be apparent to the driver must be avoided.

3. Steep grades and sharp crest vertical curves should be avoided at or near intersections.

4. Flat grades and long gentle vertical curves should be used wherever possible.

### b. Grades

The grades selected for vertical alinement should be as flat as possible, and should not be greater than the value given in Table III-4.

For streets and highways that require long upgrades, the maximum grade should be reduced so that the speed reduction of slow-moving vehicles (e.g. trucks) is not greater than 10 mph. The critical lengths of grade for these speed reductions are shown in Figure III-3. Where reduction of grade is not practical, climbing lanes should be provided to meet these speed reduction limitations.

The criteria for a climbing lane and the adjacent shoulder are the same as for any travel lane except that the climbing lane should be clearly designated by the appropriate pavement markings. Entrance to and exit from the climbing lane shall follow the same criteria as other merging traffic lanes; however, the climbing lane should not be terminated until well beyond the crest of the vertical curve. Differences in superelevation should not be sufficient to produce a change in pavement cross slope between the climbing lane and through lane in excess of 0.04 feet per foot.

Recommended gutter grades:

Rolling terrain - 0.5% desirable

Flat terrain - 0.3% desirable, 0.2% minimum

### c. Vertical Curves

Changes in grade should be connected by a parabolic curve (the vertical offset being proportional to the square of the horizontal distance). Vertical curves are required when the algebraic difference of

intersecting grades exceeds the values given in Table III-5. The length of vertical curve on a crest, as governed by stopping sight distance is obtained from Figure III-4. The minimum length of a crest vertical curve to obtain minimum passing sight distance is given in Figure III-5. The minimum length of a sag vertical curve as governed by vehicle headlight capabilities is obtained from Figure III-6.

Wherever feasible curves longer than the minimum should be considered to improve both esthetic and safety characteristics.

## 6. Alinement Coordination

Horizontal and vertical alignment should not be designed independently. Poor combinations can spoil the good points of a design. Properly coordinated horizontal and vertical alignment can improve appearance, enhance community values, increase safety and encourage uniform speed. Coordination of horizontal and vertical alignment should begin with preliminary design, during which stage adjustments can readily be made.

Proper combination of horizontal alignment and profile can be obtained by engineering study and consideration of the following general controls.

a. Curvature and grades should be in proper balance. Tangent alignment or flat curvature with steep grades, and excessive curvature with flat grades are both poor design. A logical design is a compromise between the two conditions. Wherever feasible the roadway should "roll with" rather than "buck" the terrain.

b. Vertical curvature superimposed on horizontal curvature, or vice versa, generally results in a more pleasing facility, but it should be analyzed for effect on driver's view and operation. Changes in profile not in combination with horizontal alignment may result in a series of disconnected humps visible to the driver for some distance.

c. Sharp horizontal curvature should not be introduced at or near the top of a pronounced crest vertical curve. Drivers cannot perceive the horizontal change in alignment especially at night. This condition can be avoided by setting the horizontal curve so that it leads the vertical curve or by making the horizontal curve longer. Suitable designs can be made by using design values well above the minimums.

d. Sharp horizontal curvature should not be introduced at or near the low point of a pronounced sag vertical curve to prevent an undesirable distorted appearance. Vehicle speeds often are high at the bottom of grades and erratic operation may result, especially at night.

e. On divided highways, variation of the median width and the use of independent vertical and horizontal alignment should be considered. Where right-of-way is available, a superior design without significant additional cost can result from the use of independent alignment.

Figure III-3  
 CRITICAL LENGTH VERSUS UPGRADE

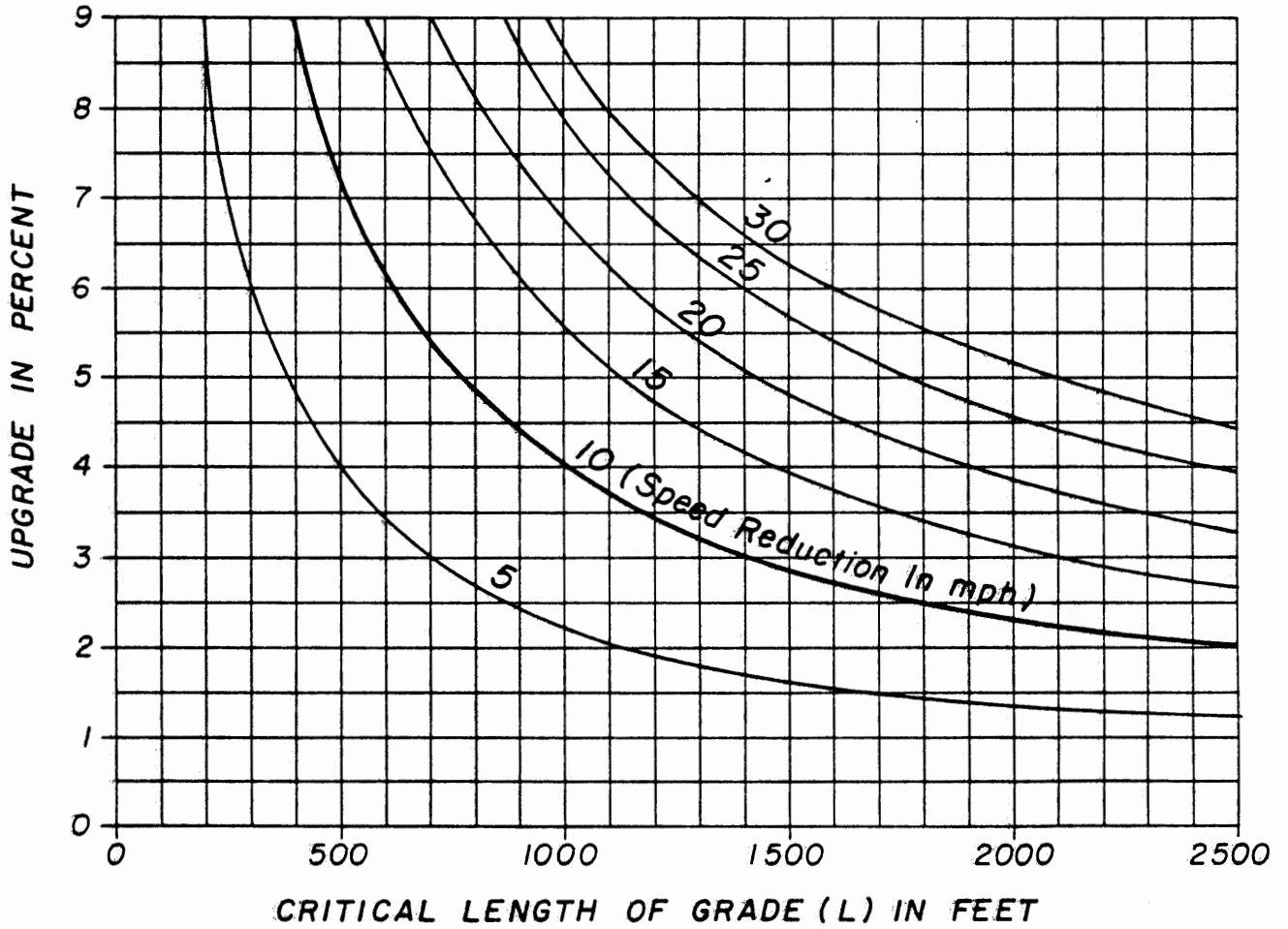

Critical lengths of grade for design, assumed typical heavy truck of 300 lb./hp., entering speed = 55 mph.



TABLE III-4

## RECOMMENDED MAXIMUM GRADES IN PERCENT

TYPE OF ROADWAY	FLAT TERRAIN							ROLLING TERRAIN						
	DESIGN SPEED* MPH							DESIGN SPEED* MPH						
	20	30	40	50	60	65	70	20	30	40	50	60	65	70
Freeway				4	3	3	3				5	4	4	4
Arterial *			5	4	3	3	3			6	5	4	4	4
Collector *		7	7	6	5	4			9	8	7	6	5	
Local *	8	7	7	6	5			11	10	9	8	6		
Industrial **		4	4	3	3				5	5	4	4		

\* May be increased by 2 percent for urban streets under extreme conditions.

\*\* Local and collector streets with significant (15% or more) truck traffic.

For short sections less than 500' and for one way downgrades, the maximum gradient may be 1% steeper.

TABLE III-5  
 MAXIMUM CHANGE IN GRADE  
 (Without Using Vertical Curve)

DESIGN SPEED (V) MPH	20	30	40	50	60	65	70
MAXIMUM CHANGE IN GRADE IN PERCENT	1.20	1.00	.80	.60	.40	.30	.20

Figure III-4

LENGTH OF CREST VERTICAL CURVE  
( Stopping Sight Distance )

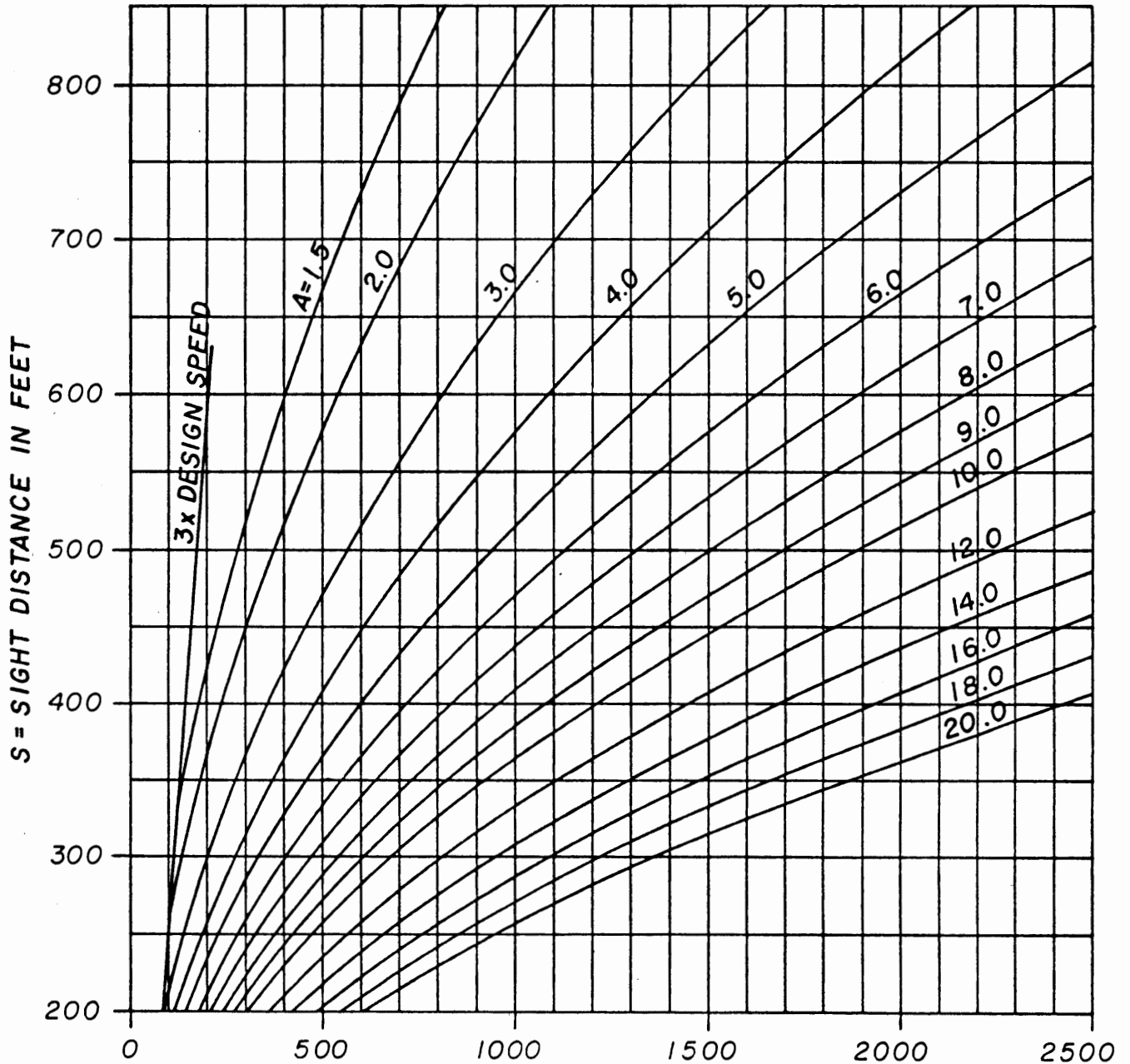

L = MINIMUM LENGTH OF VERTICAL CURVE IN FEET

Lengths of vertical curves are computed from the formula  $L = \frac{AS^2}{1329}$

A = Algebraic Difference In Grades In Percent

S = Sight Distance

Figure III-5  
**LENGTH OF CREST VERTICAL CURVE**  
*( Passing Sight Distance )*

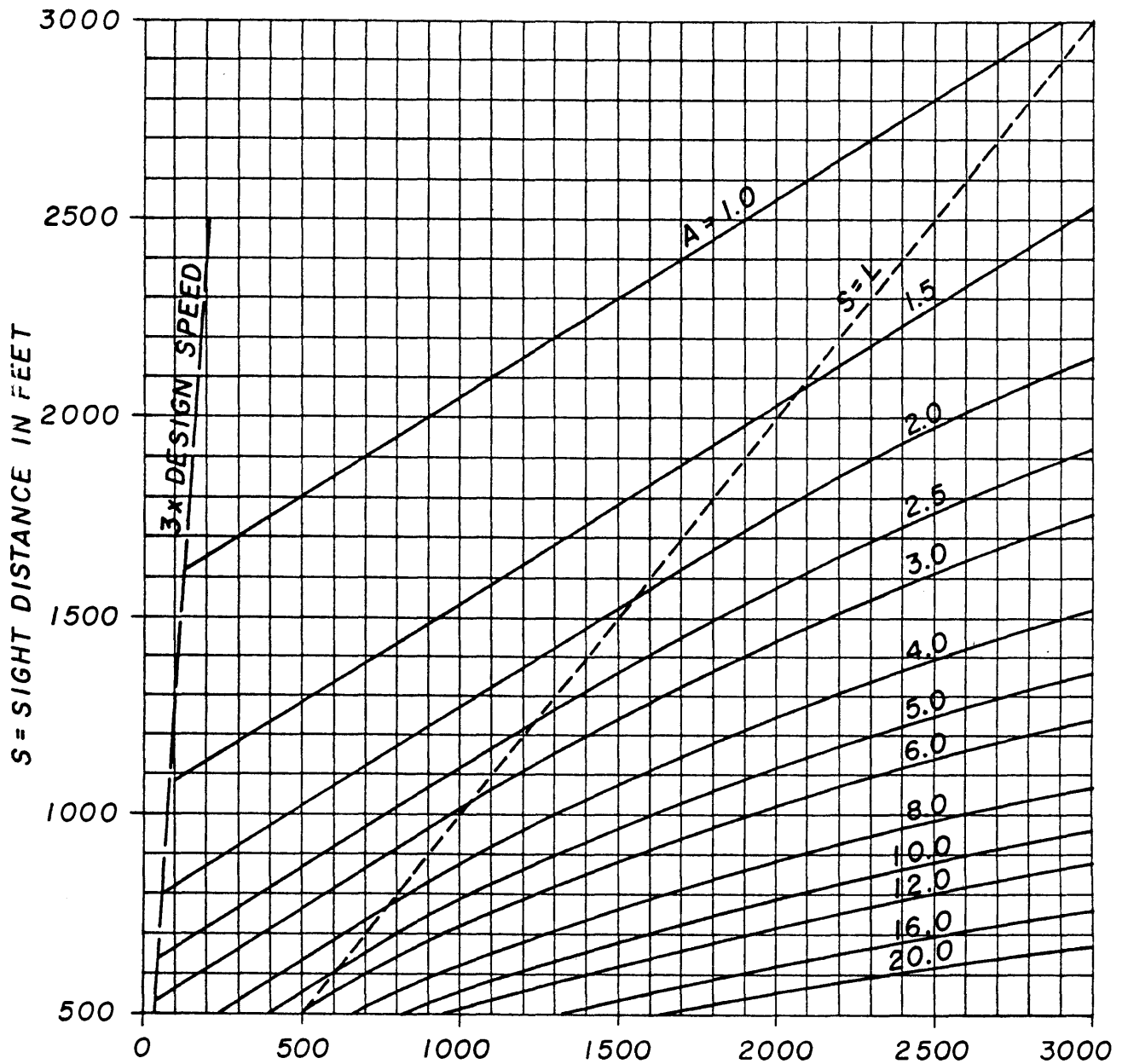

**L = MINIMUM LENGTH OF VERTICAL CURVE IN FEET**

The sight distance is computed from the following formulas:

$$S < L, L = \frac{AS^2}{3093} \quad S > L, L = 2S - \frac{3093}{A}$$

A = Algebraic Difference In Grades, Percent

S = Sight Distance

L = Length Of Vertical Curve

FIGURE III-6

LENGTH OF SAG VERTICAL CURVE ( Stopping Sight Distance )

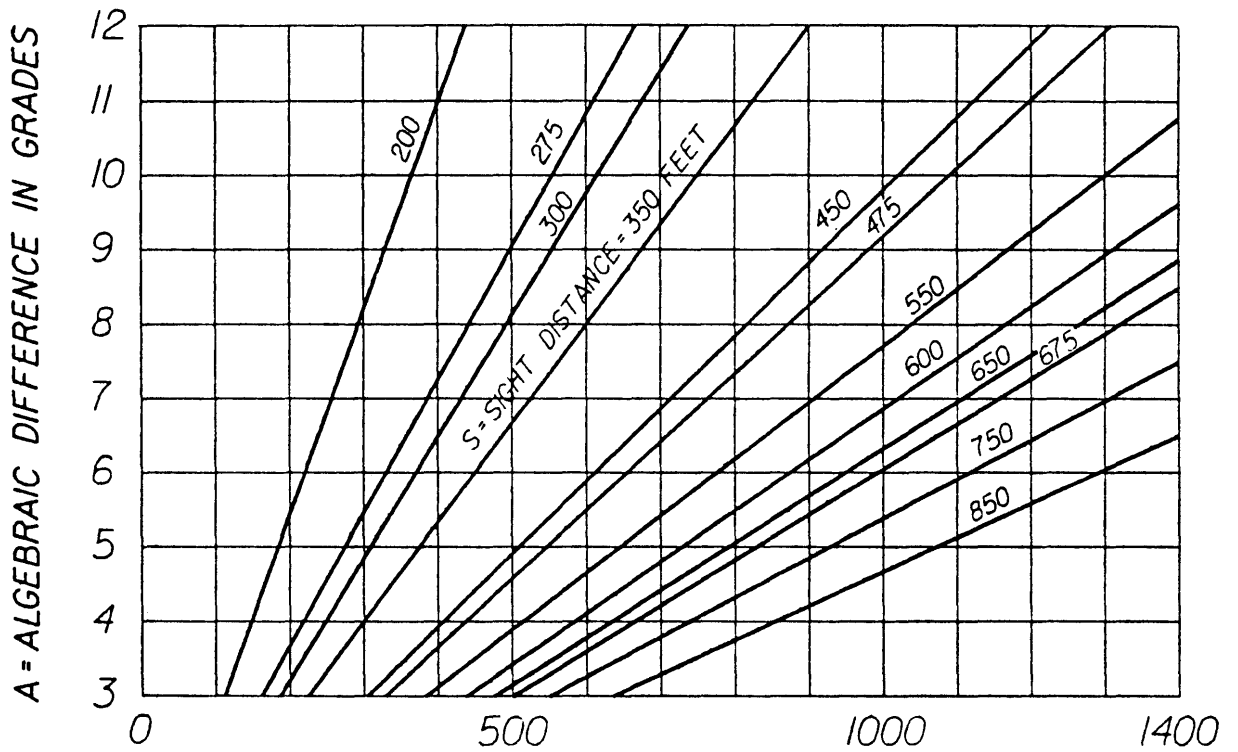

L = MINIMUM LENGTH OF VERTICAL CURVE IN FEET

HEADLIGHT SIGHT DISTANCE

Lengths of vertical curves are computed from the formula:

$$L = \frac{AS^2}{400 + 3.5(S)}$$

TABLE III-6

STOPPING SIGHT DISTANCE AND K VALUES

STOPPING SIGHT DISTANCE  
(Based on height of eye of 3.50 feet and height of object 6 inches above road surface)

Design Speed, mph	20	30	40	50	60	65	70
Stopping Sight Distance Feet	125	200	275 to 325	400 to 475	525 to 650	550 to 725	625 to 850

The length of vertical curve must never be less than three times the design speed of the highway.

$L = KA$ L = Length of vertical curve      A = Algebraic differences of grades in percent										
ROUNDED K VALUE FOR VERTICAL CURVES										
Design Speed, mph	20	30	35	40	45	50	55	60	65	70
K Value for Crest Vertical Curve $K=S^2/1329$	10	30	40 to 50	60 to 80	80 to 120	110 to 160	150 to 220	190 to 310	230 to 400	290 to 540
K Value for Sag Vertical Curve $K=S^2/400 + 3.5 (S)$	20	40	50	60 to 70	70 to 90	90 to 110	100 to 130	120 to 160	130 to 180	150 to 220

Values obtained from the charts or computed from the formula  $L=KA$  should be rounded upward when feasible.

PASSING SIGHT DISTANCE (Measured from 3.50 feet height of eye to 4.25 feet height of object above the road surface)							
Design Speed, mph	20	30	40	50	60	65	70
Minimum Passing Sight Distance, Ft.	800	1100	1500	1800	2100	2300	2500

The minimum length of vertical curve to be used on major highways should be as follows:

Design Speed, mph	50	60	70
Crest vertical curves	300'	400'	500'
Sag vertical curves	200'	300'	400'

For aesthetic value on Interstate highways the preferable minimum lengths are 1000' for crest vertical curves and 800' for sag vertical curves.

f. Horizontal alinement and profile should be made as flat as possible at interchanges and intersections where sight distance along both highways is important. Sight distances above the minimum are desirable at these locations.

g. Alinement should be designed to enhance scenic views for the motorists.

h. In residential areas, the alinement should be designed to minimize nuisance to the neighborhood.

## 7. Cross Section Elements

The design of the highway cross section should be predicated upon the design speed, terrain, adjacent land use, classification and the type and volume of traffic expected. The cross section selected should be uniform throughout a given length of street or highway without frequent or abrupt changes.

### a. Number of Lanes

The number of travel lanes is determined by several interrelated factors such as capacity, level of service and service volume. (See AASHTO "A Policy on Geometric Design of Highways and Streets - 1984" and the current "Highway Capacity Manual".)

### b. Pavement

The paved surface of all travel lanes shall be designed and constructed in accordance with the requirements set forth in Section V PAVEMENT DESIGN, CONSTRUCTION AND MAINTENANCE.

#### 1) Pavement Width

Traffic lanes should be 12 feet in width, but shall not be less than 10' in width. Streets and highways with significant truck traffic should have 12 feet wide traffic lanes. For minimum lane widths see Tables III-7 and III-8. If additional lane width is required for bicycles see FDOT Bicycle Facilities Planning and Design Manual, Revised Edition 1982.

#### 2) Pavement Cross Slope (Not in Superelevation)

The selection of pavement cross slope should be a compromise between meeting the drainage requirements and providing for smooth vehicle operation. The recommended pavement cross slope is 0.02 feet per foot. The cross slope shall not be less than 0.015 feet per foot or greater than .04 feet per foot. The change in cross slope between adjacent through travel lanes should not exceed 0.04 feet per foot.

c. Shoulders

The primary functions of a shoulder are to provide emergency parking for disabled vehicles and an alternate path for vehicles during avoidance or other emergency maneuvers. In order to fulfill these functions satisfactorily the shoulder should have adequate stability and surface characteristics. The design and construction of shoulders shall be in accordance with the requirements given in Section V PAVEMENT DESIGN, CONSTRUCTION AND MAINTENANCE.

Shoulders should be provided on all streets and highways incorporating open drainage. The absence of a contiguous emergency travel or storage lane is not only undesirable from a safety standpoint but also is disadvantageous from an operations viewpoint. Disabled vehicles that must stop in a through lane impose a severe safety hazard and produce a dramatic reduction in traffic flow.

1) Shoulder Width

Since the function of the shoulders is to provide an emergency storage or travel path, the width of all shoulders should, ideally, be at least 10 feet in width. Where economic or practical constraints are severe it is permissible, but not desirable, to reduce the shoulder width. Outside shoulders shall be provided on all streets and highways with open drainage and should be at least 6 feet wide. Facilities with a heavy total traffic volume or a significant volume of truck traffic should have outside shoulders at least 8 feet wide. The width of outside shoulders for two-lane, two-way roadways should not be less than the values given in Table III-8.

Median shoulders are desirable on all multilane divided streets and highways. For shoulder widths on multilane divided highways see Table III-9.

2) Shoulder Cross Slope

The shoulder serves as continuation of the drainage system, therefore, the shoulder cross slope should be somewhat greater than the adjacent travel lane. High quality shoulders should have a cross slope of approximately 0.03 to .06 feet per foot. The cross slope of shoulders shall not be less than 0.03 feet per foot or greater than 0.08 feet per foot. For local subdivision type streets a maximum cross slope of .12 feet per foot may be used.

Whenever possible shoulders shall be sloped away from the traffic lanes to aid in their drainage. The combination of shoulder cross slope and texture should be sufficient to promote rapid drainage and to avoid retention of surface water. The change in cross slope between a traffic lane and adjacent shoulder should not be greater than 0.07 feet per foot except on local subdivision streets where the change in cross slope should not exceed 0.10 feet per foot. Shoulders on the outside of



superelevated curves should be rounded (vertical curve) to avoid an excessive break in cross slope and to divert a portion of the drainage away from the adjacent travel lanes.

d. Medians

Median separation of opposing traffic lanes provides a beneficial safety feature and should be used wherever feasible. Separation of the opposing traffic also reduces the problem of headlight glare, thus improving the safety and comfort for night driving.

The use of medians often aids in the provision of drainage for the roadway surface particularly for highways with six or more traffic lanes. The median also provides a vehicle refuge area, a logical location for left turn storage lanes and the means for future addition of traffic lanes. In many situations the median strip aids in roadway delineation and the overall highway esthetics.

Median separation is required on the following streets and highways:

- 1) Freeways
- 2) All streets and highways with 4 or more travel lanes and with a design speed greater than 45 mph.

The nature and degree of median separation required is dependent upon the design speed, traffic volume, adjacent land use and the frequency of access. There are basically two approaches to median separation. The first is the use of horizontal separation of opposing lanes to reduce the probability of vehicles crossing the median into oncoming traffic. The second method is to attempt to limit crossovers by introducing a positive median barrier structure.

The use of horizontal separation is preferable from a safety viewpoint, if the width of median is adequate. In rural areas the use of wide medians is not only esthetically pleasing but is often more economical than barriers. In urban areas where space and/or economic constraints are severe the use of barriers is permitted to fulfill the requirements for median separation.

Medians should be free of abrupt changes in slope, discontinuities, soft ground or other hazards which would prevent the driver from retaining or regaining control of the vehicle. Consideration should be given to increasing the width and decreasing the slope of medians on horizontal curves. The requirements for a hazard-free median environment given in Section IV ROADSIDE DESIGN shall be followed in the design and construction of medians.

TABLE III-7

## MINIMUM LANE WIDTH

	Desirable Minimum Lane Width	Minimum Lane Width
Freeways	12'	12'
Major Arterials	12'	11'
Minor Arterials	12'	11'
Collectors (Major and Minor)	11'	11'
Local Roads*	10'	10'
Auxiliary Lanes	12'	10'

\*Pavement widths may be reduced for the paving of certain existing unpaved subdivision streets and low volume rural roads. See Section III-A for conditions.

TABLE III-8

MINIMUM WIDTHS OF PAVEMENT AND SHOULDERS  
FOR  
2-LANE RURAL HIGHWAYS

DESIGN SPEED	AVERAGE DAILY TRAFFIC (2-WAY)				
	< 250	250-400	400-750	750-1,600	above 1,600
30	20'	20'	22'	22'	24'
35	20'	20'	22'	22'	24'
40	20'	20'	22'	22'	24'
45	20'	20'	22'	22'	24'
50	20'	20'	22'	24'	24'
55	20'	22'	22'	24'	24'
60	20'	22'	22'	24'	24'
65	20'	22'	24'	24'	24'
ALL	WIDTH OF SHOULDER				
	Min. 6'	Min. 6' Desirable 8'	Min. 6' Desirable 10'	Min. 8' Desirable 10'	Min. 8' Desirable 10'

TABLE III-9

SHOULDER WIDTHS FOR MULTILANE RURAL  
DIVIDED HIGHWAYS

Number of Lanes. Each Direction	SHOULDER WIDTH			
	Outside		Median	
	Roadway	Bridge	Roadway	Bridge
2	12' desirable	10'	8' desirable	6'
	10' minimum		6' minimum	
3 or more	12' desirable	10'	12' desirable	10'
	10' minimum		10' minimum	

### 1) Type of Median

A wide, gently depressed median is the preferred design. This type allows a reasonable vehicle recovery area and aids in the drainage of the adjacent shoulders and travel lanes. Where space and drainage limitations are severe, narrower medians flush with the roadway are permitted. This type has the disadvantage of draining onto the roadway. Raised medians also have the same drainage deficiencies. The use of raised or painted medians is permissible.

### 2) Median Width

The median width is defined as the horizontal distance between the inside pavement edges of the opposing roadways. The selection of the median width for a given type of roadway is primarily dependent upon design speed and traffic volume. Since the probability of crossover accidents is decreased by increasing the separation, medians should be as wide as is practicable. Median widths in excess of 30 to 35 feet reduce the problem of disabling headlight glare from opposing traffic.

The desirable and minimum permitted widths of freeway medians are given in Table III-10. Where the expected traffic volume is heavy the widths should be increased over the minimum values. Median barriers may be used on urban freeways in lieu of horizontal separation if space limitation is a severe problem.

The minimum permitted median widths for multi-lane rural highways are given in Table III-11. On urban streets the median widths shall not be less than the values given in Table III-11. Where median openings or access points are frequent the median width should be increased.

The minimum median widths given in these tables may have to be increased to meet the requirements for cross slopes, drainage, and turning movements (See 9 INTERSECTION DESIGN). The median area should include adequate additional width to allow for expected additions of through lanes and left turn storage lanes. Where the median width is sufficient to produce essentially two separate, independent roadways the left side of each roadway shall meet the requirements for roadside clear zones. Changes in the median width should be accomplished by gently flowing horizontal alinement of one or both of the separate roadways.

### 3) Median Slopes

A vehicle should be able to transverse a median without turning over and with sufficient smoothness to allow the driver a reasonable chance to control his vehicle. The transition between the median slope and the shoulder (or pavement) slope shall be smooth, gently rounded and free from discontinuities.

The median cross slope should not be steeper than 6:1 (preferably not steeper than 10:1). The depth of depressed medians may be controlled by drainage requirements. Increasing the width of the median, rather than increasing the cross slope, is the proper method for developing the required median depth.

Longitudinal slopes (median profile parallel to the roadway) should be shallow and gently rounded at intersections of grade. The longitudinal slope, relative to the roadway slope, shall not exceed a ratio of 10:1 and preferably 20:1. The change in longitudinal slope shall not exceed 8:1 (change in grade of 12.5 percent).

#### 4) Median Barriers

The primary objective for placing a barrier structure in the median is to prevent vehicles from entering the opposing traffic stream, either accidentally or intentionally. Median barriers may also be used to reduce the glare produced by oncoming vehicle headlights. When selecting the type of barrier, care should be exercised to avoid headlight flicker through barriers.

The use of median barriers to reduce horizontal separation is permitted on facilities with substantially full control of access. Frequent openings in the barrier for intersections or crossovers expose the barrier end, which constitutes a severe hazard at locations with an inherently high accident potential. Median barriers may be considered for urban freeways and major arterials with controlled access.

Median barriers should be considered on controlled access facilities if the median width is less than the minimum permitted values given in Table III-10. The median barrier should not be placed closer than 10 feet from the inside pavement edge. Further requirements for median barriers are given in Section IV ROADSIDE DESIGN.

#### e. Roadside Clear Zone

The roadside clear zone is that area outside the traveled way, available for use by errant vehicles. Vehicles frequently leave the traveled way during avoidance maneuvers, and due to loss of control by the driver (falling asleep, etc.) or due to the collisions with other vehicles. The primary function of the clear zone is to allow space and time for the driver to retain control of his vehicle and avoid or reduce the consequences of collision with roadside objects. This area also serves as an emergency refuge location for disabled vehicles.

TABLE III-10

MEDIAN WIDTH FOR FREEWAYS

(Urban or Rural)

DESIGN SPEED MPH	MINIMUM PERMITTED MEDIAN WIDTH, FEET	DESIRABLE MINIMUM MEDIAN WIDTH, FEET
60 AND OVER	60 **	100
UNDER 60	40*	80

\*Applicable for urban areas only.

\*\* For new construction.  
40 foot minimum allowed  
when lanes added to median

TABLE III-11

MEDIAN WIDTH, FEET FOR RURAL HIGHWAYS  
(Multilane Facilities)

Design Speed	Minimum	Desirable Minimum
55 MPH and Over	40	50
Under 55 MPH	22	40

MEDIAN WIDTH, FEET FOR URBAN STREETS

Design Speed	Minimum	Desirable Minimum
55 MPH and Over	25	40
45 - 50 MPH	19.5	30
40 and Less	15.5	22

Paved medians with a minimum width of 10 feet may be used for two-way turn lanes and painted medians when design speeds are 45 mph or less.



The design of the roadside must also provide for adequate drainage of the roadway. Drainage swales within the clear zone should be gently rounded and free of discontinuities. Where large volumes of water must be carried, the approach should be to provide wide rather than deep drainage channels. Side slopes and drainage swales that lie within the clear zone shall be free of protruding drainage structures.

In the design of the roadside, the designer should consider the consequences of a vehicle leaving the traveled way at any location. It should always be the policy that the protection of vehicles and occupants shall take priority over the protection of roadside objects. Further criteria and requirements for safe roadside design are given in Section IV ROADSIDE DESIGN.

#### 1) Roadside Clear Zone Width

The width of the clear zone should be wide as is practicable. The minimum permitted widths are given in Table III-12. These are minimum values only and should be increased wherever feasible.

In rural areas it is desirable, and frequently economically feasible, to substantially increase the width of the clear zone. Where traffic volumes and speeds are high, the width should be increased. The clear zone on the outside of horizontal curves should be increased due to the high probability of vehicles leaving the roadway at a high angle.

#### 2) Roadside Slopes

The slopes of all roadsides should be as flat as possible to allow for a safe traversal by out-of-control vehicles. The transition between the shoulder and adjacent side slope should be rounded and free from discontinuities. The adjacent side slope within the clear zone shall not be steeper than 3:1. The side slopes should be reduced on the outside of horizontal curves.

Where roadside ditches or cuts require back slopes, the steepness of the backslope should normally not (within the clear zone) exceed a ratio of 4:1. Ditch bottoms should be at least four feet wide and can be flat, or gently rounded.

#### 3) Criteria for Guardrail

If space and economic constraints are severe, it is permissible, but not desirable, to use guardrails in lieu of the requirements for width and slope of clear zone. Where the previously described requirements for clear zone are not met, guardrails (or other longitudinal barriers) should be used. Guardrails should also be considered for protection of pedestrian pathways or protection from immovable roadside hazards.

TABLE III-12  
MINIMUM WIDTH OF CLEAR ZONE

TYPE OF FACILITY	DESIGN SPEED, MPH							
	25 & Below	30	35	40	45	50	55	60 & Above
	MINIMUM CLEAR ZONE, FEET							
RURAL •	6	6 Local 10 Collectors 14 Arterials	6 Local 10 Collectors 14 Arterials	10 Collectors 14 Arterials	14 Arterials & Collectors ADT < 1500	14 Arterials & Collectors ADT < 1500	18 Arterials & Collectors ADT < 1500	24 Arterials & Collectors ADT < 1500
					18 Arterials & Collectors ADT ≥ 1500	18 Arterials & Collectors ADT ≥ 1500	24 Arterials & Collectors ADT ≥ 1500	30 Arterials & Collectors ADT ≥ 1500
URBAN *	2½	4 **	4 **	4 **	4 **	N/A ••	N/A ••	N/A ••

\*From face of curb.

\*\*On projects where the 4 foot minimum offset cannot be reasonably obtained and other alternatives are deemed impractical, the minimum may be reduced to 2½ feet.

• Use Rural for Urban facilities when no curb & gutter is present.

•• Curb and Gutter not to be used on facilities with Design Speed > 45mph.

Note: ADT in Table III-12 refers to Design Year ADT.

The general policy to be followed is that guardrails should be used if impact with the guardrail is less likely or less severe than impact with roadside objects. Further requirements and design criteria for guardrails are given in Section IV ROADSIDE DESIGN.

f. Curbs

Curbs may be used to provide drainage control and to improve delineation of the roadway. The two general classes of curbs are barrier curbs and mountable curbs and each has numerous types. Both types of curbs may be designed with a gutter to form a combination curb and gutter section. Barrier curbs are relatively high and steep faced, designed to discourage vehicles from leaving the roadway. Mountable curbs are low with flat sloping surfaces designed so that vehicles can mount them when required.

Where curbs are used on facilities with speeds greater than 40 mph, they should be of the mountable rather than the barrier type. The height of mountable curbs shall not exceed 6 inches. Further design criteria and requirements for curbs are given in Section IV ROADSIDE DESIGN.

g. Parking

Parking on street rights of way should be avoided.

h. Right-of-Way

The acquisition of sufficient right-of-way is necessary in order to provide space for a safe street or highway. The width of the right-of-way required depends upon the design of the roadway, the arrangement of bridges, underpasses and other structures, and the need for cuts or fills. The right-of-way acquired should be sufficient to:

a. Allow development of the full cross section including adequate medians and roadside clear zones.

b. Provide for the layout of safe intersections, interchanges and other access points.

c. Allow for adequate sight distance at all points, particularly on horizontal curves at an intersection and other access points.

d. Provide, where appropriate additional buffer zones to improve roadside safety, noise attenuation and the overall esthetics of the street or highway.

e. Provide adequate space for placement of necessary pedestrian and bicycle facilities.

f. Allow for future lane additions, increases in cross section or other improvements. Frontage roads should also be considered in the ultimate development of many high volume facilities.

g. Provide for construction of future grade separations or other intersection improvements at selected crossroads.

The acquisition of wide rights-of-way is costly, but it is necessary to allow for the construction and future improvement of safe streets and highways. The minimum right-of-way shall be at least 50' for all two-lane roads. For pre-existing conditions when the existing right-of-way is less than 50' effort should be made to acquire the necessary right-of-way.

Local cul-de-sac and dead-end streets having an ADT of less than 250 and a length of 600 feet or less may utilize a right-of-way of less than 50 feet if all elements of the typical section meets the standards included in this manual.

The right-of-way for frontage roads may be reduced depending on the typical section requirements and the ability to share right-of-way with the adjacent highway facility.

i. Changes in Typical Section

1) General Criteria

Changes in cross section should be avoided. When changes in widths, slopes or other elements are necessary they should be affected in a smooth, gradual fashion.

2) Lane Deletions and Additions

a) The addition or deletion of traffic lanes should be undertaken on tangent sections of roadways.

b) The approach to lane deletions and additions should have ample advance warning and sight distance.

3) The termination of lanes (including auxiliary lanes) shall meet the general requirements for merging lanes.

4) Where multiple lanes are intermittently provided on two-lane, two-way highways, median separation should be provided. Advance warning in the form of multiple signs or pavement markings should be provided.

5) Structures

The pavement, median and shoulder width should be carried across structures such as bridges and box culverts. Shoulder widths for

multilane rural divided highway bridges may be reduced as shown in Table III-9. The designer should evaluate the economic practicality of utilizing dual vs. single bridges for roadway sections incorporating wide medians.

The minimum clear roadway width for bridges on urban streets with curb and gutter shall be the same as the curb-to-curb width of the approach roadway. Sidewalks on the approaches should be carried across all structures. Curbed sidewalks should not be used adjacent to traffic lanes when design speeds exceed 45 mph. When the bridge rail (barrier wall) is placed between the traffic and sidewalk it should be offset a minimum distance of 21' from the edge of the travel lane, wide curb lane or bicycle lane. For long (500' or greater) and/or high level bridges it is desirable to provide an offset distance that will accommodate a disabled vehicle. The transition from the bridge to the adjacent roadway section may be made by dropping the curb at the first intersection or well in advance of the traffic barrier, or reducing the curb in front of the barrier to a low mountable curb with a gently sloped traffic face.

a) Horizontal Clearance

Supports for bridges, barriers or other structures should be placed at or beyond the required shoulder. Where possible, these structures should be located outside of the required roadside clear zone.

b) Vertical Clearance

Vertical clearances should be adequate for the type of expected traffic. Freeways and major arterials shall have a vertical clearance of at least 16 feet. Other streets and highways should have a clearance of 16 feet unless the provision of a reduced clearance is fully justified by a specific analysis of the situation. Provision for additional clearance (3 to 6 inches) is recommended to allow for future resurfacing.

c) End Treatment

The termini of guardrails, bridge railings and abutments and other structures should be constructed so as to protect vehicles and their occupants from serious impact. Requirements for end treatment of structures are given in Section IV ROADSIDE DESIGN.

8. Access Control

All new facilities (and existing if possible) should have some degree of access control since each point of access produces a traffic conflict, thereby substantially increasing the accident potential. The control of access is one of the most effective, efficient, and economical methods for improving the capacity and safety characteristics of streets and highways. The reduction of the frequency of access points and the restriction of turning and crossing maneuvers, which should be primary objectives, is accomplished more effectively by the design of the roadway

geometry than by the use of traffic control devices. Design criteria for access points are presented under the general requirements for intersection design.

a. Justification

The justification for control of access should be based upon several factors including safety, capacity, economics, and esthetics.

b. General Criteria

1) Location of Access Points

a) All access locations should have adequate sight distance available for the safe execution of entrance, exit, and crossing maneuvers.

b) Locations of access near structures, decision points or the termination of highway lighting should be avoided.

c) Driveways should not be placed near intersections or other points that would tend to produce traffic conflict.

2) Spacing of Access Points

a) The spacing of access points should be adequate to prevent conflict or mutual interference of traffic flow.

b) Separation of entrance and exit ramps should be sufficient to provide adequate distance for required weaving maneuvers.

c) Adequate spacing between access and decision points is necessary to avoid burdening the driver with the need for rapid decisions or maneuvers.

d) Frequent median openings should be avoided.

e) The use of a frontage road or other auxiliary path is recommended on minor arterials and higher classifications where the need for direct driveway or minor road access is frequent.

3) Restrictions of Maneuvers

a) Where feasible, the number and type of permitted maneuvers (crossing, turning, slowing, etc.) should be restricted.

b) The restriction of crossing maneuvers may be accomplished by the use of grade separations, and continuous medians.

c) The restrictions of left turns is achieved most effectively by continuous medians.

d) Channelization should be considered for the purposes of guiding traffic flow and reducing vehicle conflicts.

#### 4) Turn Lanes

a) Deceleration lanes for right turn (and left turn where permitted) exits should be provided on all high speed facilities.

b) Storage (or deceleration lanes) to protect turning vehicles should be provided, particularly where turning volumes are significant.

c) Acceleration lanes are desirable for entrance maneuvers onto high-speed streets and highways.

d) Special consideration should be given to the provisions for deceleration, acceleration, and storage lanes in commercial or industrial areas with significant truck traffic.

#### 5) Grade Separation

a) Grade separation intersections should be considered for junctions of major arterial streets and highways.

b) Grade separation (or an interchange) should be utilized when the expected traffic volume exceeds the intersection capacity.

c) Grade separation should be considered to eliminate conflict or long waiting periods at potentially hazardous intersections.

#### c. Control for All Limited Access Highways

Entrances and exits on the right side only are highly desirable for all limited access highways. Acceleration and deceleration lanes are mandatory. Intersections shall be accomplished by grade separation (interchange) and should be restricted to connect with arterials or collector roads.

The control of access on freeways should conform to the requirements given in Table III-13. The spacing of exits and entrances should be increased wherever possible to reduce conflicts. Safety and capacity characteristics are improved by restricting the number and increasing the spacing of access points.

#### d. Control of Urban Streets

The design and construction of urban, as well as rural, highways should be governed by the general criteria for access control previously outlined. In addition, the design of urban streets should be in accordance with the criteria listed below:

1) The general layout of local and collector streets should follow a branching network, rather than a highly interconnected grid pattern.

TABLE III-13

ACCESS CONTROL FOR ALL LIMITED ACCESS HIGHWAYS

		URBAN	RURAL
MINIMUM SPACING			
	Interchanges	1 to 3 miles	3 to 25 miles
MANEUVER RESTRICTIONS			
	Crossing Maneuvers	VIA Grade Separation Only	
	Exit and Entrance	From Right Side Only	
	Turn Lanes Required	Acceleration Lane at all Entrances Deceleration Lane at all Exits	



2) T-intersections in branching networks are recommended, particularly for local and collector streets.

3) The street network should be designed to reduce, consistent with origin/destination requirements, the number of crossing and left turn maneuvers.

4) Where practical, one-way street patterns should be considered.

5) The design of the street layout should be predicated upon reducing the need for traffic signals.

6) U-turns should be discouraged.

7) The use of a public street or highway as an integral part of the internal circulation pattern for commercial property should be discouraged.

8) The number of driveway access points should be restricted as much as possible through areas of strip development.

9) Special consideration should be given to providing turn lanes (auxiliary lane for turning maneuver) where the total volume or truck volume is high.

10) Major traffic generators may be exempted from the restrictions on driveway access if the access point is designed as a normal intersection adequate to handle the expected traffic volume.

These are minimum requirements only, and it is generally desirable to use more stringent criteria for control of access.

e. Control for Rural Highways

The design of rural highways should be in accordance with the general criteria for access control for urban streets. The use of acceleration and deceleration lanes on all high-speed highways (particularly if truck traffic is significant) is strongly recommended.

f. Land Development

It should be the policy of each agency with responsibility for highway design, construction or maintenance to promote close liaison with lawmaking, zoning, building and planning agencies. Cooperation should be solicited in the formulation of laws, regulations and master plans for land use, zoning and highway construction. Further requirements and criteria for access control and land use relationships are given in Section II LAND DEVELOPMENT.

## 9. Intersection Design

Intersections increase traffic conflicts and the demands upon the driver, and are inherently hazardous locations. The design of an intersection should be predicated upon reducing motor vehicle, bicycle and pedestrian conflicts, minimizing the confusion and demands upon the driver for rapid and/or complex decisions and providing for smooth traffic flow. The location and spacing of intersections should follow the requirements presented in 8. Access Control.

The additional effort and expense required to provide a high-quality intersection is justified by the corresponding safety benefits. The overall reduction in accident potential derived from a given expenditure for intersection improvements is generally much greater than the same expenditure for improvements along an open roadway. Poor intersections also reduce the traffic capacity, thereby limiting the overall capacity and economic value of the street or highway.

The requirements and design criteria contained in this section are applicable to all driveways, intersections, and interchanges. All entrances to, exits from, or interconnections between streets and highways are subject to these design standards.

### a. General Criteria

The layout of a given intersection may be influenced by constraints unique to that particular location or situation. The design shall, however, conform to sound principles and criteria for safe intersections. The general criteria include the following:

1) The layout of the intersection should be as simple as is practicable. Complex intersections which tend to confuse and distract the driver produce inefficient and hazardous operation.

2) The intersection arrangement should not require the driver to make rapid and/or complex decisions. The provision of spacious or open intersection or interchange generally increases the distance between successive decision points.

3) The layout of the intersection should be clear and understandable so that a proliferation of signs, signals or markings is not required to adequately inform and direct the driver.

4) The design of intersections, particularly along a given street or highway, should be as consistent as possible.

5) The approach roadways should be free from steep grades or sharp horizontal or vertical curves.

6) Intersections with driveways or other roadways should be as close to right angle as possible.

7) Adequate sight distance should be provided to present the driver a clear view of the intersection and to allow for safe execution of crossing and turning maneuvers.

8) The design of all intersection elements should be consistent with the design speeds of the approach roadways.

9) The intersection layout and channelization should encourage smooth flow and discourage wrong-way movements.

10) Special attention should be directed toward the provision of safe roadside clear zones.

11) The provision of special turn lanes should be in conformance with the criteria set forth in 8. Access Control.

12) The requirements for bicycle and pedestrian movements should receive special consideration.

b. Sight Distance

Inadequate sight distance is a contributing factor in the cause of a large percentage of intersection accidents. The provision of adequate sight distance at intersections is, therefore, absolutely essential and should receive a high priority in the design process.

1) General Criteria

General criteria to be followed in the provision of sight distance include the following:

a) Sight distance exceeding the minimum stopping sight distance should be provided on the approach to all intersections (entrances, exits, stop signs, traffic signals and intersecting roadways). The use of proper approach geometry free from sharp horizontal and vertical curvature will normally allow for adequate sight distance.

b) The approaches to exits or intersections (including turn, storage and deceleration lanes) should have adequate sight distance to allow for safe speed and lane change maneuver.

c) Adequate sight distance should be provided on the through roadway approach to entrances (from acceleration or merge lanes, stop or yield signs, driveways or traffic signals) to provide capabilities for defensive driving. This lateral sight distance should include as much length of the entering lane or intersecting roadway as is feasible. A clear view of entering vehicles is necessary to allow through traffic to aid merging maneuvers and to avoid vehicles which have "run" or appear to have the intention of running stop signs or traffic signals.

d) Approaches to school or pedestrian crosswalks should have sight distance exceeding the minimum values. This should also include a clear view of the adjacent pedestrian pathways.

e) Sight distance in both directions should be provided for all entering roadways (driveways, merge lanes and intersecting roadways) to allow entering vehicles to avoid through traffic.

f) Safe stopping sight distances shall be provided throughout all intersections, including turn lanes, speed change lanes and turning roadways.

g). Where particular problems of hazards are encountered, the use of lighting (see Section VI ROADWAY LIGHTING) should be considered to improve intersection sight distance for night driving.

## 2) Obstructions to Sight Distance

The provisions for sight distance are limited by the highway geometry and the nature and development of the area adjacent to the roadway. Where line-of-sight is limited by vertical curvature or obstructions, stopping sight distance shall be based upon an eye height of 3.50 feet and an object height of 0.50 feet. At exits or other locations where the driver may be uncertain as to the roadway alignment, a clear view of the pavement surface should be provided. At locations requiring a clear view of other vehicles or pedestrians for the safe execution of crossing or entrance maneuvers, the sight distance should be based upon a driver's eye height of 3.50 feet and an object height of 3.00 feet (and preferably 1.50 feet). The height of eye for truck traffic may be increased for determination of line-of-sight obstructions for intersection maneuvers. Obstructions to sight distance at intersections include the following:

a) Any property that is not under the highway agency's jurisdiction through direct ownership or other regulations shall be considered as an area of total sight distance obstruction.

b) Areas which contain vegetation (trees, shrubbery, grass, etc.) that cannot easily be trimmed or removed by regular maintenance activity should be considered as sight obstructions.

c) Parking lanes shall be considered as obstructions to line-of-sight. Parking shall be prohibited within clear areas required for sight distance at intersections.

d) Large (or numerous) poles or support structures for lighting, signs, signals or other purposes may constitute sight obstructions. The adverse effect upon sight distance created by poles and signs near intersections should be carefully investigated.

In order to ensure the provision for adequate intersection sight distance on-site inspections should be conducted before and

after construction, including placement of signs, lighting, guardrails or other obstructions to intersection sight distance.

### 3) Stopping Sight Distance

The provision for safe stopping sight distance at intersections and on turning roadways is even more critical than on open roadways. Vehicles are more likely to be traveling in excess of the design or posted speed and drivers are frequently distracted from maintaining a continuous view of the upcoming roadway.

#### a) Approach to Stops

The approach to stop signs, yield signs or traffic signals should be provided with a sight distance no less than values given in Table III-14. These values are applicable for any street, highway or turning roadway. The driver should, at this required distance, have a clear view of the intersecting roadway as well as the sign or traffic signal.

Where the approach roadway is on a grade or vertical curve, the sight distance should be no less than the values shown in Figure III-7. In any situation where it is feasible, sight distances exceeding those should be provided. This is desirable to allow for more gradual stopping maneuvers and to reduce the likelihood of vehicles running through the stop signs or signals. Advance warning for stop signs is desirable.

#### b) On Turning Roadways

The required stopping sight distance at any location on a turning roadway (loop, exit, etc.) shall be based upon the design speed at that point. Ample sight distance should be provided since the driver is burdened with negotiating a curve travel path and the available friction factor for stopping has been reduced by the roadway curvature. Wherever feasible the sight distances given in Table III-14 or Figure III-7 should be provided. The available sight distance shall, however, be no less than the minimum values obtained from the latest publication of AASHO. Due to the inability of vehicle headlights to adequately illuminate a sharply curved travel path, roadway lighting should be considered for turning roadways.

### 4) Sight Distance for Intersection Maneuvers (Non-Signalized Intersections)

#### a) Crossing Maneuver

The sight distance required for the safe execution of a crossing maneuver is dependent upon the acceleration capabilities of the vehicle, the crossing distance and the design speed of the street or highway to be crossed. The minimum required sight distance in both directions (measured from the entering roadway centerline) for various classes of

vehicles is given in Figures III-8, III-9 and III-10. This minimum sight distance should be provided for a given vehicle class if it constitutes 5 percent or more of the total crossing traffic or if that class experiences 30 or more crossings per day.

The crossing distance (W) shown in Figure III-11 shall include the total width of roadway to be crossed plus the initial offset of the vehicle from the pavement edge, plus the vehicle length. The roadway width shall include the median as well as all through travel lanes. The initial position of the vehicle shall be assumed to be at least 10 feet from the nearest travel lane. Where the median width is at least 5 feet wider than the design vehicle length (see Table III-2) the crossing may be assumed to take place in two separate maneuvers.

On median separated roadways sight distance to the left may be based upon the distance (W) required to clear the first set of travel lanes.

The setback (see Figure III-11) required for sight distance shall be at least 5 feet greater than the vehicle offset. All obstructions to the required sight distance shall be removed within the area shown in Figure III-11. At intersections with traffic signals it is desirable to provide this same sight distance capability.

The minimum sight distances obtained from Figures III-8, III-9, and III-10 should be used only for level conditions. The time required to cross the major highway is materially affected by the grade of the crossing. Normally the grade across an intersection is so small that it need not be considered, but when curvature of the major road requires the use of superelevation, the grade across it may be significant. In this case the sight distance along the major road should be greater. Figure III-12 should be used to obtain the minimum sight distance for crossing when grade is considered.

b) Left Turn Crossings

Sight distance for left turn crossings shall be no less than the values given in Figures III-8, III-9 and III-10. This clear view shall include the cross section of the opposing traffic lanes which the vehicle must cross in executing the left turn. The crossing distance (W) shall include the pavement width of the opposing through lanes, plus the vehicle offset plus the length of the crossing vehicle. This required sight distance should be provided at intersections with traffic signals as well as for exits to stop-controlled roadways.

TABLE III-14  
 SIGHT DISTANCE FOR APPROACH TO STOPS  
 (rounded values)

DESIGN SPEED (MPH)	20	30	40	50	60	65	70
STOPPING SIGHT DISTANCE (FEET)							
Minimum	125	200	275	400	525	550	625
Desirable	200	250	325	475	650	725	850

Figure III-7

SIGHT DISTANCES FOR APPROACH TO STOP ON GRADES

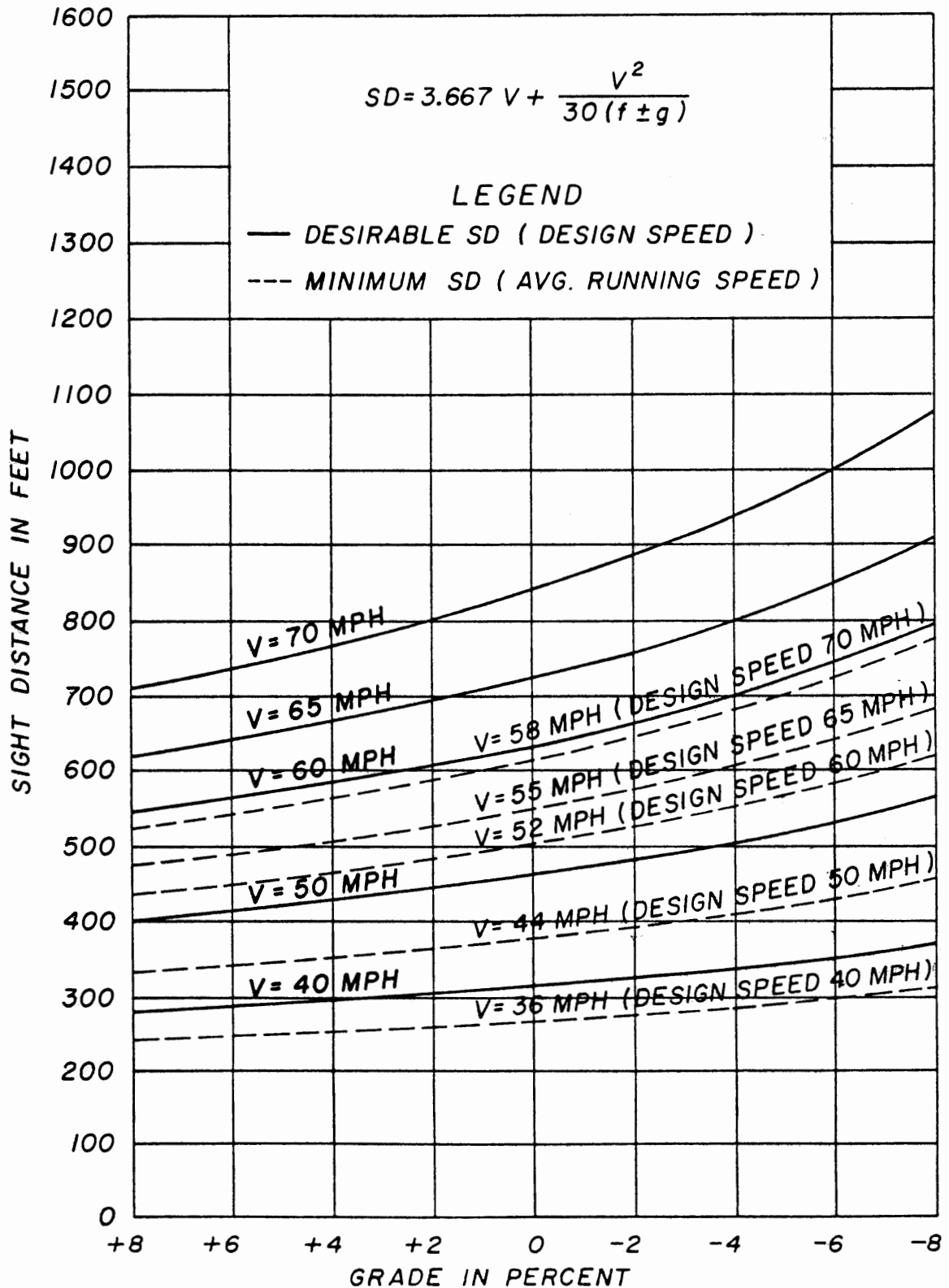

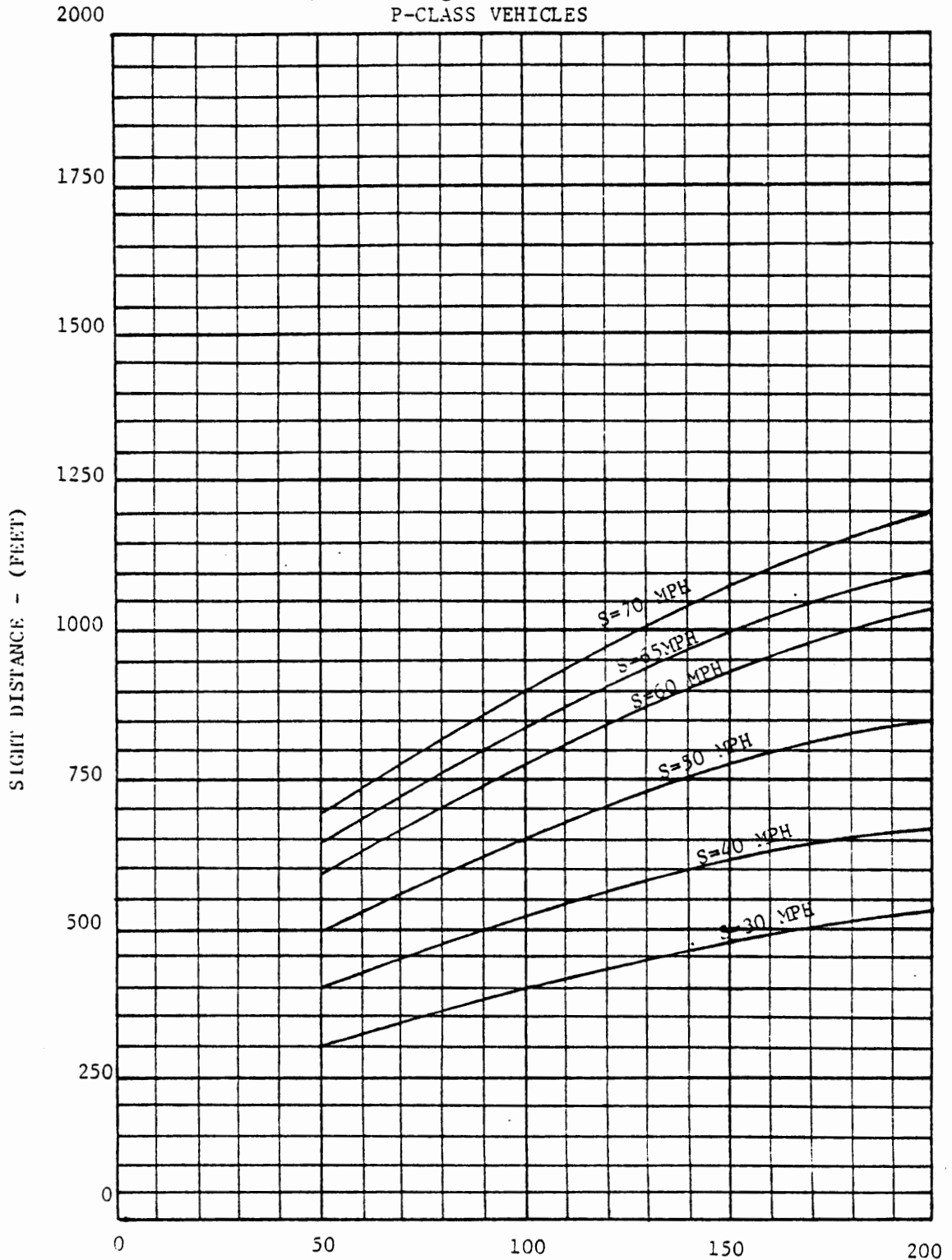

FIGURE III-8

SIGHT DISTANCE FOR CROSSING MANEUVER

(Affect of grade not included)

P-CLASS VEHICLES



WIDTH (W) IN FEET

FIGURE III-9

SIGHT DISTANCE FOR CROSSING MANEUVER

(Affect of grade not included)

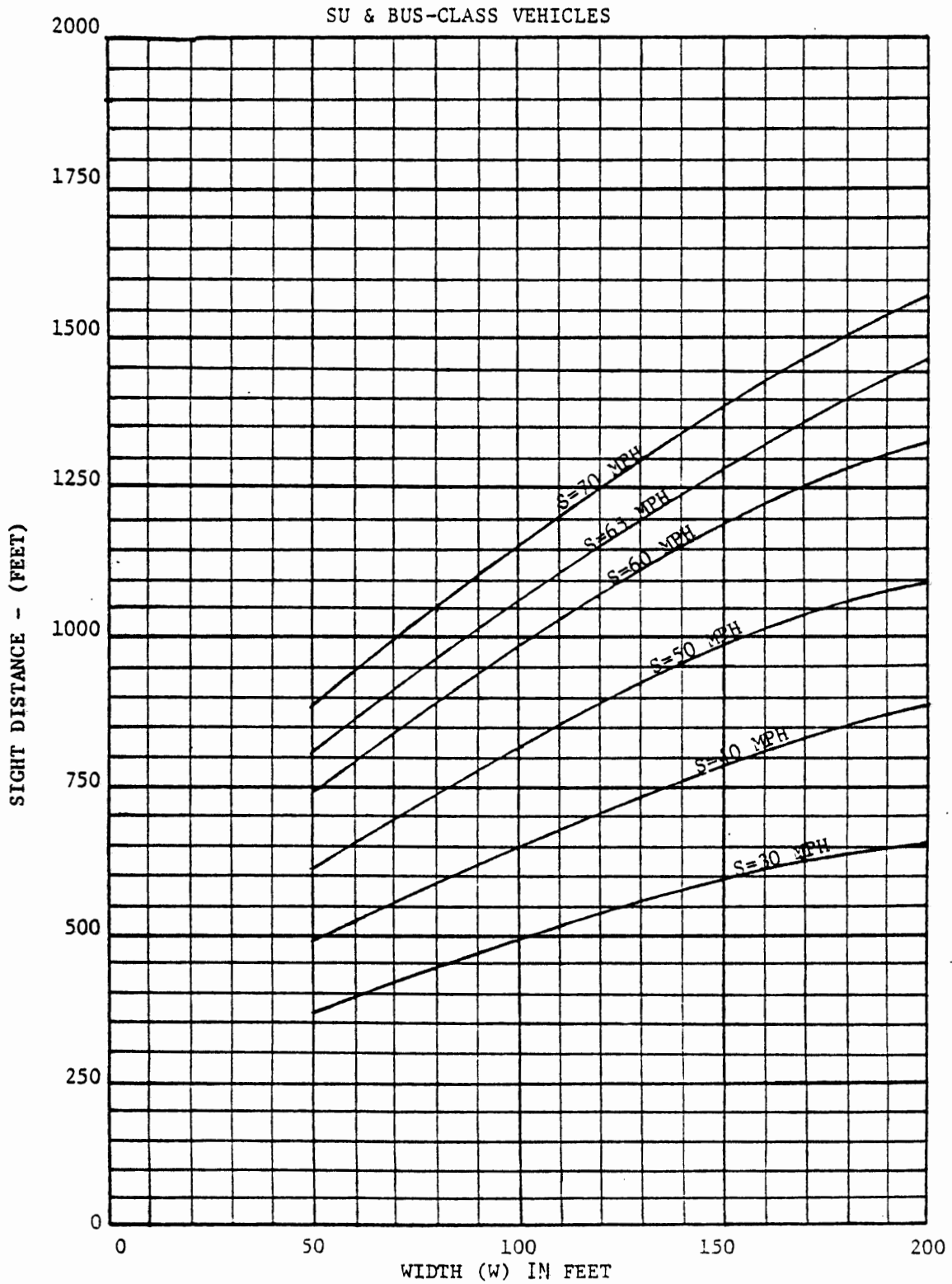
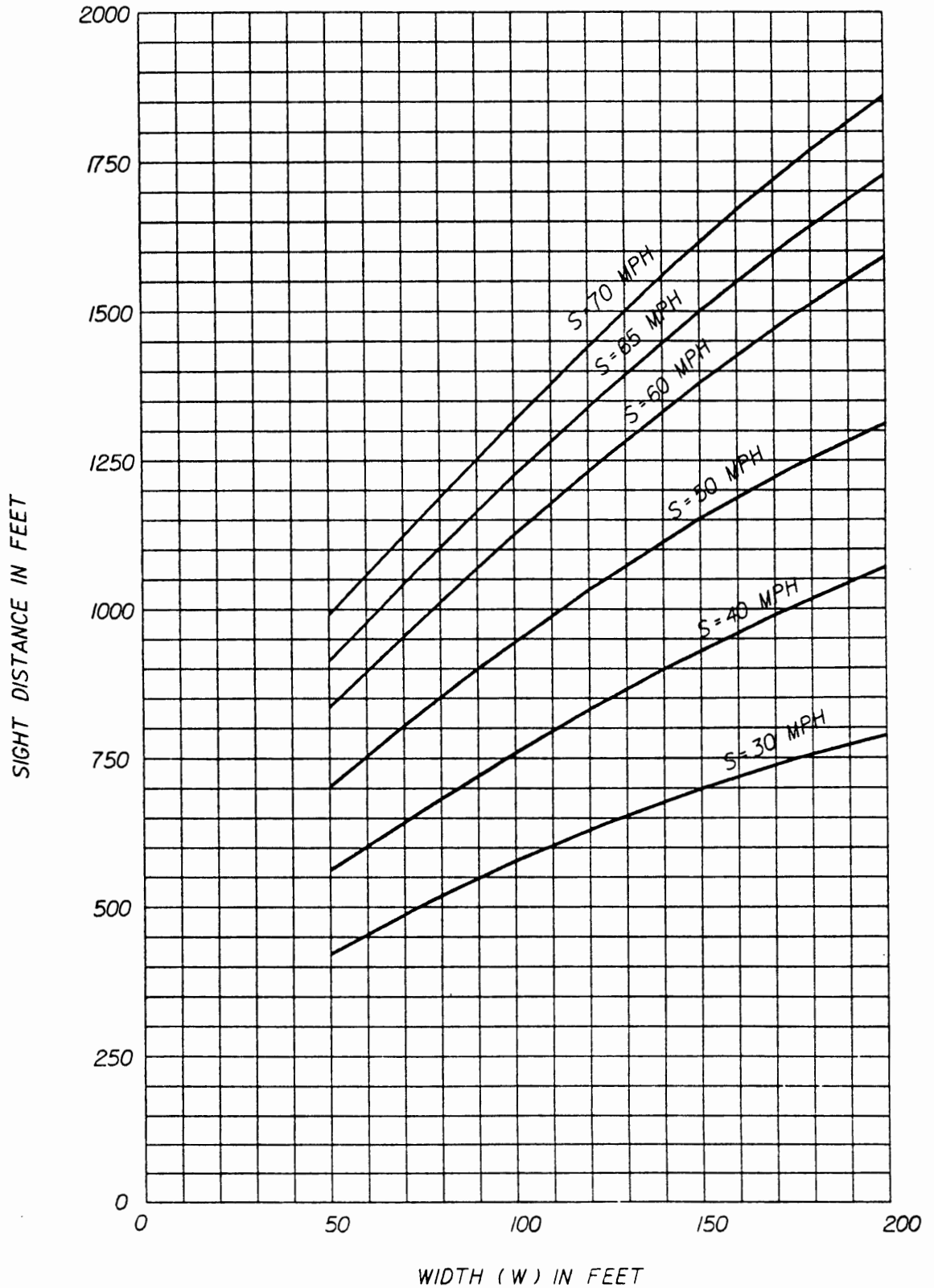

FIGURE III-10

SIGHT DISTANCE FOR CROSSING MANEUVER

(Affect of Grade Not Included)

WB-CLASS VEHICLES



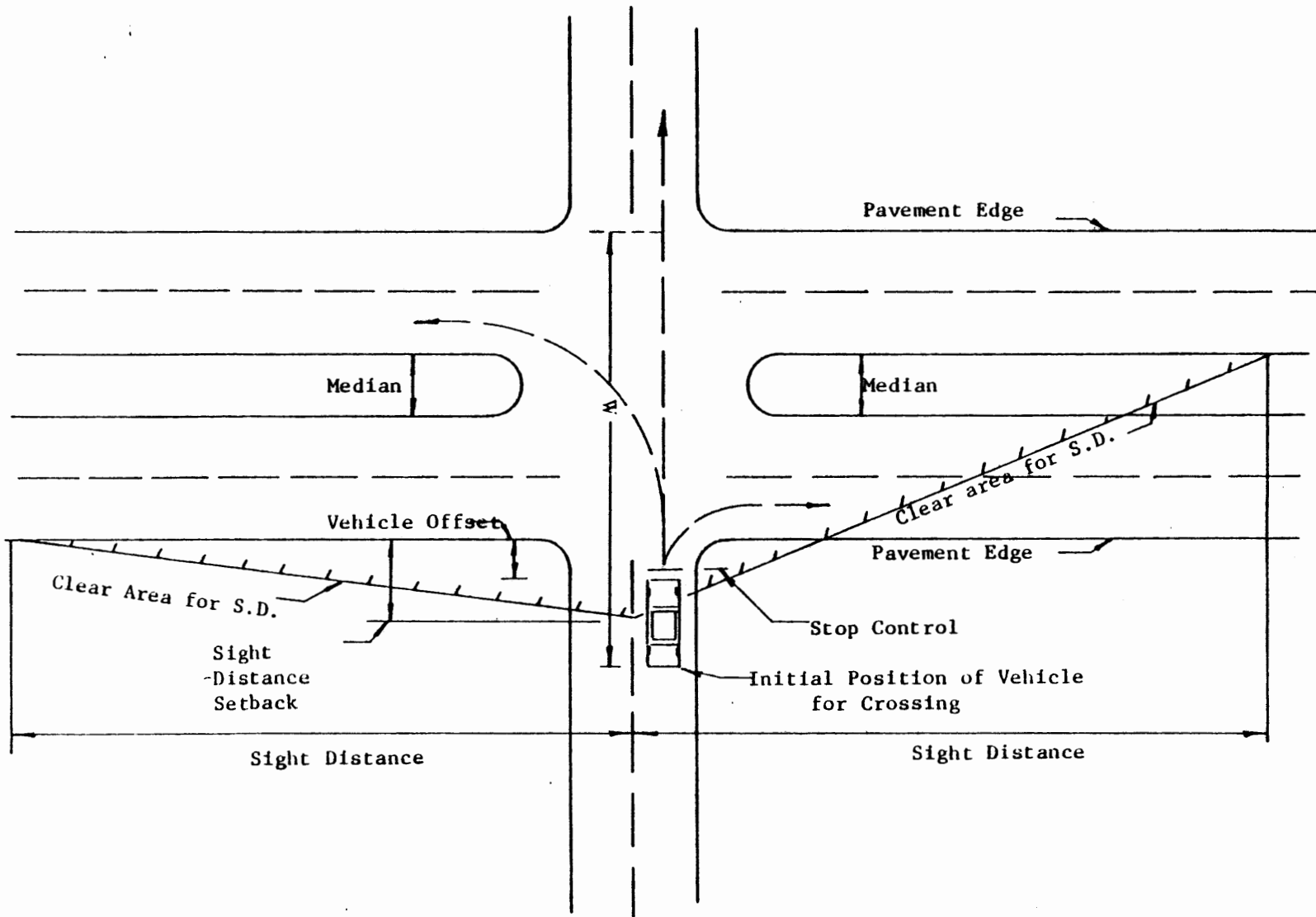

INTERSECTION CONFIGURATION

FIGURE III-11

FIGURE III-12

SIGHT DISTANCE AT INTERSECTIONS

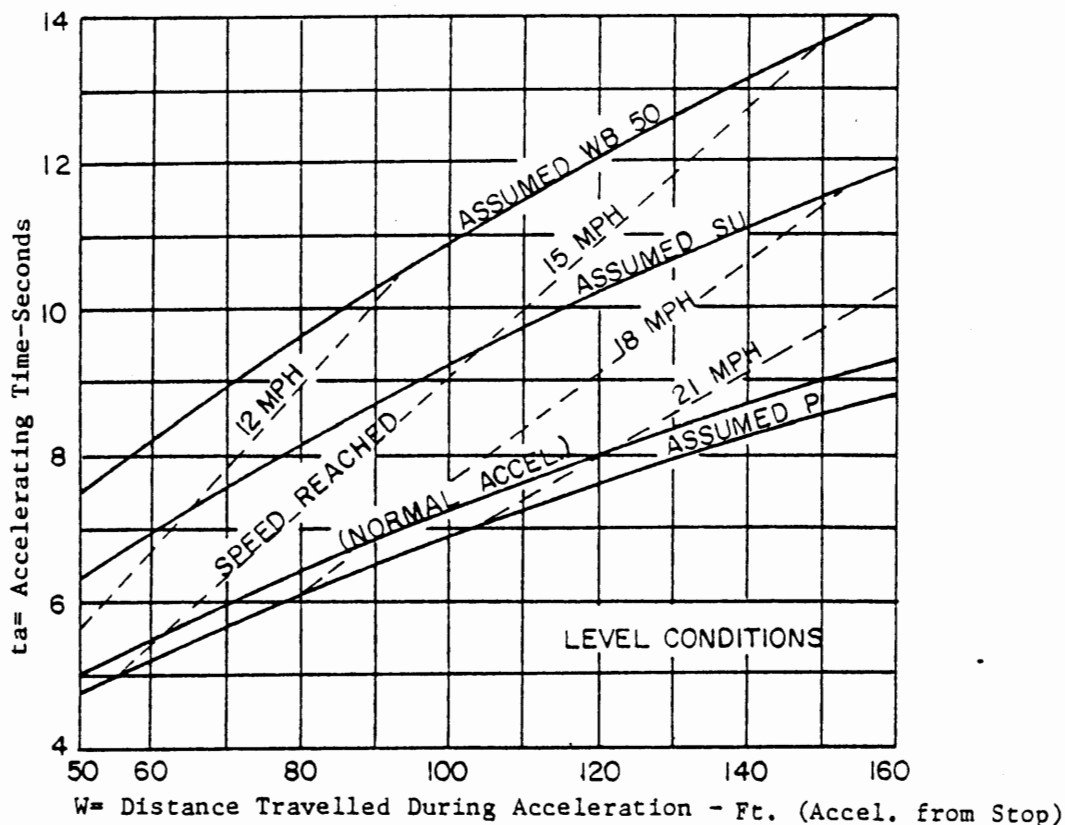

For WB-40 design vehicles, use WB-50 curve.

For Bus design vehicles, use SU

The sight distance required to allow the design vehicle to cross the intersection is computed from the following formula:

$$d = 1.47 V (J + t_a)$$

d = minimum sight distance along the major highway (ft.)

V = design speed of major highway (MPH)

J = driver reaction time (Assumed as 2 sec.)

$t_a$  = Maneuver time determined from the graph.

Design Vehicle	Adjustment factor for $t_a$ , based on crossing grade rate				
	-4%	-2%	0%	+2%	+4%
P	0.7	0.9	1	1.1	1.3
SU & Bus	0.8	0.9	1	1.1	1.3
WB - 50	0.8	0.9	1	1.2	1.7

The value of  $t_a$  obtained from the graph, adjusted by the above ratio can be used in the formula  $d=1.47V(J+t_a)$ , to determine the proper sight distance for the crossing grade condition.

TABLE III-15

LENGTH OF TAPER FOR USE IN CONJUNCTION  
WITH FULL WIDTH SPEED-CHANGE LANES

Design Speed, MPH	30	40	50	60	65	70
Length of Taper, Feet *	150	190	230	270	290	300

\* For urban street auxiliary lanes shorter tapers may be used due to lower operating speeds. Refer to AASHTO Policy on Geometric Design of Highways and Streets for allowable taper rates.

TERMINATION OF MERGING LANES

FIGURE III-13

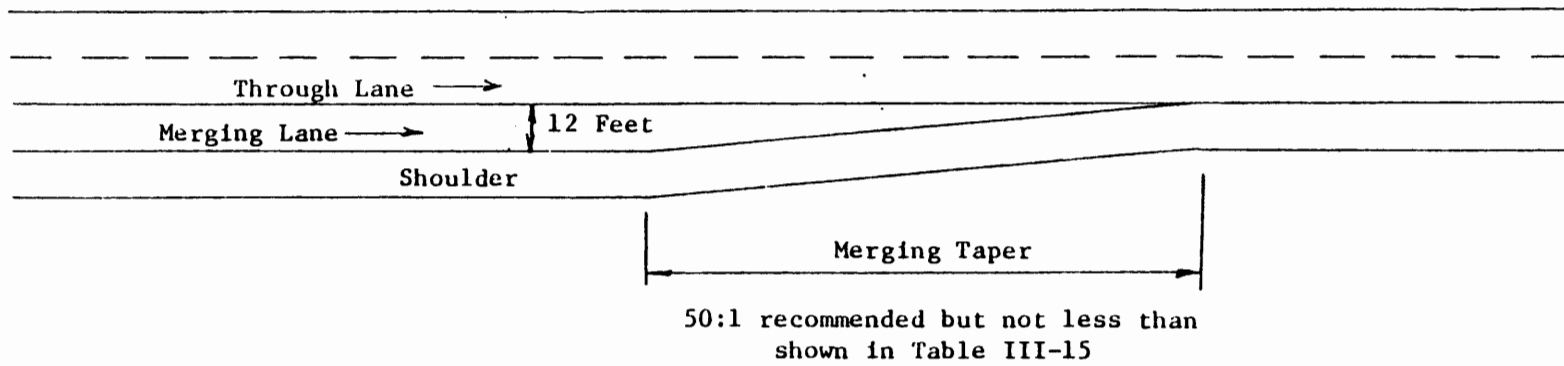

### c) Auxiliary Lanes

Auxiliary lanes are desirable for the safe execution of speed change maneuvers (acceleration and deceleration) and for the storage and protection of turning vehicles. Auxiliary lanes for exit or entrance turning maneuvers shall be provided in accordance with the requirements set forth in 8. Access Control. The pavement width and cross slopes of auxiliary lanes should meet the minimum requirements for all travel lanes. Shoulders and clear zones should be provided in accordance with the same requirements for other travel lanes.

#### 1) Merging Maneuvers

Lane change or merging maneuvers occur at the termination of climbing lanes, lane drops and entrance acceleration or turning lanes. The location provided for this merging maneuver should, where possible, be on a tangent section of the roadway and should be of sufficient length to allow for a smooth, safe transition. The provision of ample distance for merging is essential to allow the driver time to find an acceptable gap in the through traffic and then execute a safe merging maneuver. It is recommended that a merging taper be on a 50:1 transition but in no case shall the length be less than that set forth in Table III-15. The termination of this lane (including the pavement) should be clearly visible from both the merging and through lane and should correspond to the general configuration shown in Figure III-13. Advance warning of the merging lane termination should be provided. Lane drops shall be marked to provide a safe merging maneuver.

#### 2) Acceleration Lanes

Acceleration lanes are required for all entrances to freeways. Acceleration lanes are recommended for entrances to all high-speed (design speed greater than 50 mph) facilities and locations with heavy traffic volumes. Any street or highway with a large percentage of truck traffic should be considered for acceleration lane entrances.

The distance required for an acceleration maneuver is dependent upon the vehicle acceleration capabilities, the grade, the initial entrance speed and the final speed at the termination of the maneuver. The distances required for acceleration on level roadways for passenger cars are given in Table III-16. Where acceleration occurs on a grade the required distance is obtained by using Tables III-16 and III-17.



The final speed at the end of the acceleration lane should, desirably, be assumed as the design speed of the through roadway. The length of acceleration lane provided should be at least as long as the distance required for acceleration between the initial and final speeds. Due to the uncertainties regarding vehicle capabilities and driver behavior additional length is desirable. The acceleration lane should be followed by a merging taper (similar to Figure III-13) not less than that length set forth in Table III-15. The termination of acceleration lanes should conform to the general configuration shown for merging lanes in Figures III-13. Recommended acceleration lanes for freeways are given on page III - 69.

### 3) Exit Lanes

Auxiliary lanes for exiting maneuvers provide space outside of the through lanes for vehicle deceleration for the protection and storage of turning vehicles.

#### a) Deceleration Lanes

The primary function of deceleration lanes is to provide a safe travel path for vehicles decelerating from the operating speed on the through lanes. Deceleration lanes are required for all freeway exits and are desirable on all high-speed (design speed greater than 50 mph) streets and highways.

The distance required for deceleration of passenger cars is given in Table III-16.

The required distance for deceleration on grades is obtained from Tables III-16 and III-17.

The length of deceleration lanes shall be no less than the values obtained from Tables III-16 and III-17 and should be increased wherever feasible. The initial speed should, desirably, be taken as the design speed of the highway. The final speed should be the design speed at the exit (e.g. a turning roadway) or zero if the deceleration lane terminates at a stop or traffic signal. A reduction in the final speed to be used is particularly important if the exit traffic volume is high, since the speed of these vehicles may be significantly reduced.

The entrance to deceleration (and climbing) lanes should conform to the general configuration shown in Figure III-14. The initial length of straight taper, as shown in Table III-16 may be utilized as a portion of the total required deceleration distance. The pavement surface of the deceleration lane should be clearly visible to approaching traffic so that drivers are aware of the maneuvers required. Recommended deceleration lanes for freeways are given on page III - 68.

TABLE III-16

DESIGN LENGTHS OF SPEED CHANGE LANES  
Flat Grades - 2 Percent or Less

Design speed of turning roadway curve, mph		Stop condition	15	20	25	30	35	40	45	50
Minimum curve radius, feet			50	90	150	230	310	430	550	690
Design speed of highway mph	Length of taper, feet *	Total length of DECELERATION LANE, including taper, feet: All main highways								
40	190	325	300	275	250	200	—	—	—	—
50	230	425	400	375	350	325	275	—	—	—
60	270	500	500	475	450	425	400	325	300	—
65	290	550	550	525	500	475	450	375	325	—
70	300	600	575	550	550	525	500	425	400	350
Design speed of highway mph	Length of taper, feet	Total length of ACCELERATION LANE, including taper, feet:								
40	190	—	325	250	225	—	—	—	—	—
50	230	—	700	625	600	500	400	—	—	—
60	270	—	1125	1075	1000	900	800	600	400	—
70	300	—	1550	1500	1400	1325	1225	1000	825	575

\* For urban street auxiliary lanes shorter tapers may be used due to lower operating speeds. Refer to AASHTO Policy on Geometric Design of Highways and Streets for allowable taper rates.

TABLE III-17

RATIO OF LENGTH OF SPEED CHANGE LANE ON GRADE  
TO LENGTH ON LEVEL

DECELERATION LANE			ACCELERATION LANE					
Design Speed of Highway mph	Ratio		Design Speed of Highway mph	Design Speed of Turning Roadway, mph				
All	3 - 4% upgrade 0.9	3 - 4% downgrade 1.2	40	20	30	40	50	All speeds
						3 - 4% upgrade		
	5 - 6% upgrade 0.8	5 - 6% downgrade 1.35	50	1.3	1.3	---	---	0.7
			60	1.3	1.4	1.4	---	0.65
			70	1.4	1.5	1.5	1.6	0.6
				1.5	1.6	1.7	1.8	0.6
				5 - 6% upgrade				5 - 6% downgrade
Ratios in this table multiplied by the values in table III-16 give the length of speed change lane for the respective grade.			40	1.5	1.5	---	---	0.6
			50	1.5	1.7	1.9	---	0.55
			60	1.7	1.9	2.2	2.5	0.5
			70	2.0	2.2	2.6	3.0	0.5

#### b) Storage Lanes

Where exit lanes are required (see 8 Access Control) or desirable on low-speed streets and highways, storage lanes may be used in place of or in conjunction with deceleration lanes. Storage lanes should be used on all facilities. Although the primary function of storage lane is to provide protection and storage for turning vehicles, it is, of course, desirable to provide sufficient length to allow for deceleration capabilities. Storage lanes should conform to the general configuration shown in Figure III-15.

At unsignalized intersections, the storage length, exclusive of taper, may be based on the number of turning vehicles which are likely to arrive in an average 2-minute period within the peak hour, (storage in feet =  $2 \times \frac{25}{60} \times$  number of turning vehicles per hour). The

length of storage lanes for unsignalized intersections may be obtained from the table on Figure III-15. The full-width portion of storage lanes should, where possible, be increased to allow for expected storage of vehicles (see Table III-2 for vehicle lengths). As a minimum requirement, storage for at least two passenger cars should be provided.

On arterial streets (Design speed 45 mph or less) tapers preceding storage lanes, approaching intersections at grade, may be shorter than those given in Table III-16. (See AASHO for recommended length).

#### d) Turning Roadways

The design and construction of turning roadways shall meet the same general requirements for through roadways, except for the specific requirements given in the subsequent sections.

##### 1) Design Speed

Lanes for turning movements at grade intersections may, where justified, be based upon a design speed as low as 10 mph. Turning roadways with design speeds in excess of 40 mph shall be designed in accordance with the requirements for through roadways.

A variable design speed may be used to establish cross section and alignment criteria for turning roadways that will experience acceleration and deceleration maneuvers.

FIGURE III-14

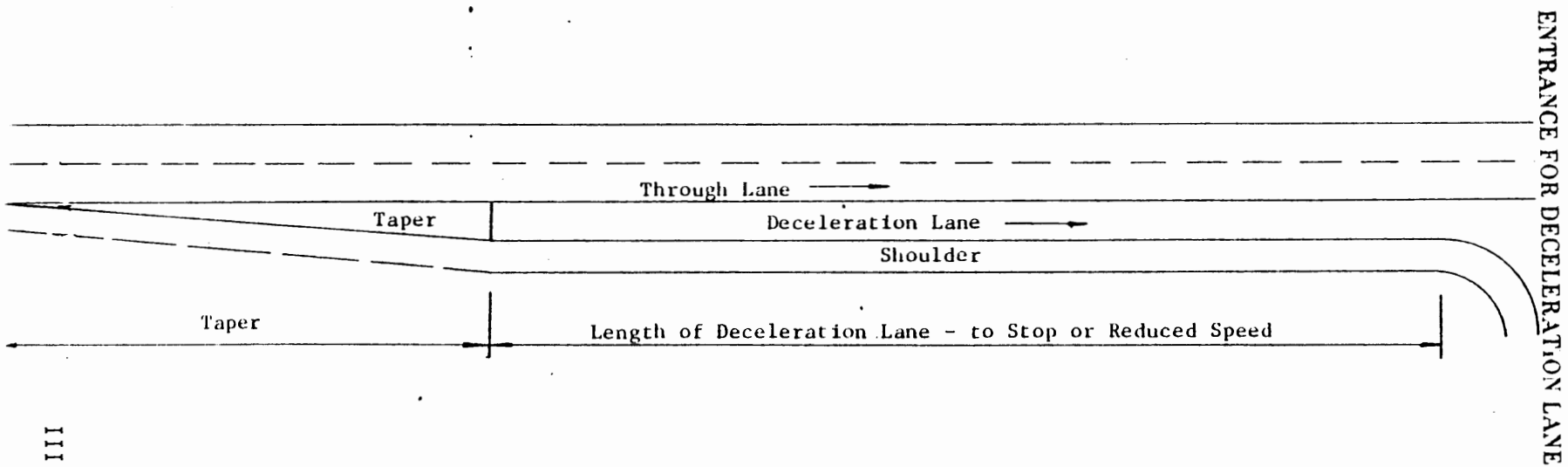

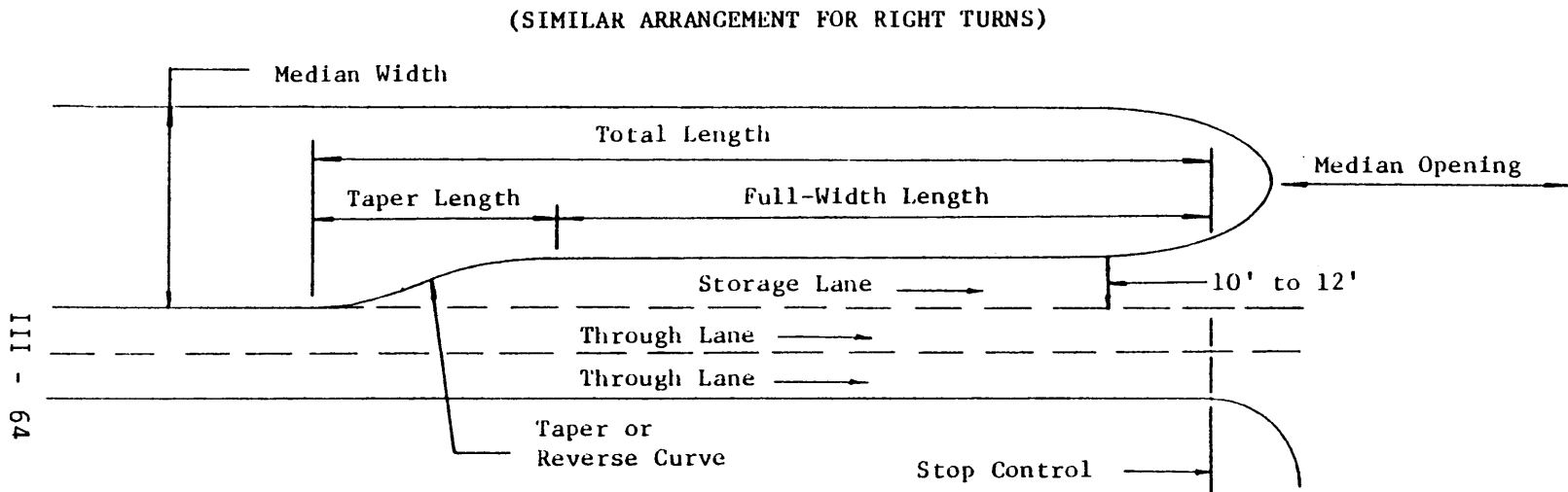

TYPICAL STORAGE LANE

FIGURE III-15

Storage Length - Unsignalized Intersections

Turning Vehicles per hour	30	60	100	200	300
Required Storage Length, feet	25	50	100	175	250

At signalized intersections the required storage length depends on the signal cycle length, the signal phasing arrangement, and rate of arrivals and departures of turning vehicles.

## 2) Horizontal Alinement

### a) Superelevation

Recommended superelevation rates for turning roadways are given in AASHTO. ("A Policy on Geometric Design of Highways and Streets - 1984" and "A Policy on Geometric Design of Rural Highways - 1965").

### b) Curvature

The minimum permitted radii (maximum degree) of curvature for various values of superelevation are given in AASHTO ("A Policy on Geometric Design of Highways and Streets - 1984" and "A Policy on Geometrics Design of Rural Highways - 1965"). These should be considered as minimum value only and the radius of curvature should be increased wherever feasible.

### c) Superelevation Transition

Recommended superelevation transition (runoff) rates are given in AASHTO. ("A Policy on Geometric Design of Highways and Streets - 1984" and "A Policy on Geometric Design of Rural Highways - 1965").

## 3) Vertical Alinement

Grades on turning roadways should be as flat as practical and long vertical curves should be used wherever feasible. The length of vertical curves shall be no less than necessary to provide minimum stopping sight distance. Minimum stopping distances and K values for turning roadways are given in AASHTO ("A Policy on Geometric Design of Highways and Streets - 1984" and "A Policy on Geometric Design of Rural Highways - 1965").

## 4) Cross Section Elements

### a) Number of Lanes

One-way turning roadways are often limited to a single travel lane. In this case the total width of the roadway shall be sufficient to allow traffic to pass a disabled vehicle. Two-way, undivided turning roadways should be avoided. Medians or barriers should be utilized to separate opposing traffic on turning roadways.

### b) Travel Lanes

The width of all travel lanes should be sufficient to accommodate (with adequate clearances) the turning movements of the expected types of vehicles. The minimum required lane widths for turning roadways are given in AASHTO. ("A Policy on Geometric Design of Highways

and Streets - 1984"). Changes in lane widths should be gradual and should be accomplished in coordination with adequate transitions in horizontal curvature.

c) Shoulders

On one-lane turning roadways serving expressways and other principal arterials (loops, ramps, etc.) the right hand shoulder shall be at least 6 feet wide. The left hand shoulder should be at least 6 feet wide in all cases. On two-lane, one-way roadways both shoulders shall be at least 6 feet wide. Where guardrails or other barriers are used, they shall be placed at least 8 feet from edge of travel lane. Guardrail should be placed 2 feet outside the normal shoulder width.

d) Clear Zones

Turning roadways should, as a minimum, meet all open-highway criteria for clear zones on both sides of the roadway. The areas on the outside of curves should be wider and more gently sloped than the minimum values for open highways. Guardrails or similar barriers shall be used if the minimum width and slope requirements cannot be obtained.

Further criteria and requirements for roadside design are given in Section IV ROADSIDE DESIGN.

e) At-Grade Intersections

1) Turning Radii

Where right turns from through or turn lanes will be negotiated at low speeds (less than 10 mph) the minimum turning capabilities of the vehicle may govern the design. It is desirable that the turning radius and the required lane width be provided in accordance with the criteria for turning roadways. The radius of the inside pavement edge should, however, be sufficient to allow the expected vehicles to negotiate the turn without encroaching upon the shoulder or adjacent travel lanes. Increasing this radius is desirable since many drivers do not always follow the optimum path around a curve.

Where turning roadway criteria are not used, the radius of the inside pavement edge should be no less than 25 feet. The use of three-centered compound curves is also a reasonable practice to allow for transition into and out of the curve. The recommended radii and arrangement of compound curves instead of a single simple curve is given in AASHTO ("A Policy on Geometric Design of Highways and Streets - 1984".)



## 2) Cross Section Correlation

The correlation of the cross sections of two intersecting roadways is frequently difficult. A careful analysis should be conducted to ensure that changes in slope are not excessive and that adequate drainage is provided. At stop-controlled intersections, the through roadway cross section should be carried through the intersection without interruption. Minor roadways should approach the intersection at a slightly reduced elevation so that the main highway cross section is not disturbed. At signalized intersections it is sometimes necessary to remove part of the crown in order to avoid an undesirable hump in one roadway.

Intersections of grade or cross slope should be gently rounded to improve vehicle operation. Pavement generally should be sloped toward the intersection corners to provide superelevation for turning maneuvers and to promote proper drainage.

Where islands are used for channelization the width of travel lanes for turning movements shall be no less than the widths recommended by AASHTO.

## 3) Median Openings

Median openings should be restricted in accordance with the requirements presented in 8 Access Control. Where a median opening is required the length of the opening shall be no less than 40'. Median curbs shall be terminated gradually without the exposure of abrupt curb ends. The termination of median barriers shall be accomplished in accordance with the requirements given in Section IV ROADSIDE DESIGN.

## 4) Channelization

Channelization of intersections at grade is the regulation or separation of conflicting movements into definite travel paths by islands, markings, or other means to promote safe orderly traffic flow. The major objective of channelization is to clearly define the appropriate paths of travel and thus assist in the prevention of vehicles deviating excessively or making wrong maneuvers. Channelization may be used effectively to define the proper path for exits, entrances, and intersection turning movements.

The methods used for channelization should be as simple as possible and consistent in nature. The channelization intersection should appear open and natural to the approaching driver. Channelization should be informative rather than restrictive in nature.

The use of low easily-mounted curbs and flush medians and islands can provide adequate delineation in most cases. Islands should be clearly visible and in general should not be smaller than 100 square feet in area. The use of small and/or numerous islands should be avoided.

Pavement markings are a useful and effective tool for providing delineation and channelization in an informative rather than restrictive fashion. The layout of all traffic control devices should be closely coordinated with the design of all channelization.

f. Driveways

Direct driveway access to arterials and major collectors should be discouraged. All turnouts to adjacent property should be designed so that vehicles can enter or leave from adjacent traffic lane.

Driveways from major traffic generators or those with any significant truck traffic shall be designed as normal intersections.

g. Interchanges

The design of interchanges for the intersection of a freeway with a major highway, collector/distributor road or other freeway is a complex problem. The location and spacing of interchanges should follow the requirements presented in 8 Access Control. The design of interchanges shall follow the general intersection requirements for deceleration, acceleration, merging maneuvers, turning roadways, and sight distance.

Interchanges, particularly along a given freeway, should be reasonably consistent in their design. A basic principle in the design should be to develop simple open interchanges that are easily traversed and understandable to the driver. Complex interchanges with a profusion of possible travel paths are confusing and hazardous to the motorist and are generally inefficient.

Intersections with minor highways or collector/distributor roads may be accomplished by simple diamond interchanges. The intersection of exit and entrance ramps with the crossroad shall meet all intersection requirements.

The design of freeway exits should conform to the general configurations shown below Table III-18. Exits should be on the right and should not be placed on horizontal curves. Where deceleration on an exit loop is required, the deceleration alignment should be designed so that the driver receives adequate warning of the approaching increase in curvature. This is best accomplished by gradually increasing the curvature and thus the resulting centrifugal force. This increasing centrifugal force provides warning to the driver that he must slow down. A clear view of the exit loop should also be provided. The length of deceleration shall be no less than the values obtained from Table III-18.

TABLE III-18

MINIMUM DECELERATION LENGTHS FOR EXIT TERMINALS

Highway Design Speed, mph	L = Deceleration Length - Feet								
	For Design Speed of Exit Curve - mph								
	Stop Condition	15	20	25	30	35	40	45	50
30	235	185	160	140	-----	-----	-----	-----	-----
40	315	295	265	235	185	155	-----	-----	-----
50	435	405	385	355	315	285	225	175	-----
60	530	500	490	460	430	410	340	300	240
65	570	540	530	490	480	430	380	330	280
70	615	590	570	550	510	490	430	390	340

EXPRESSWAY EXIT TERMINALS

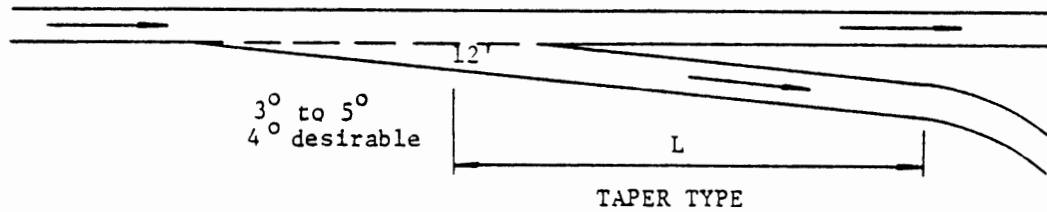

Recommended when design speed at exit curve is 50 MPH or greater and when approach visibility is good.

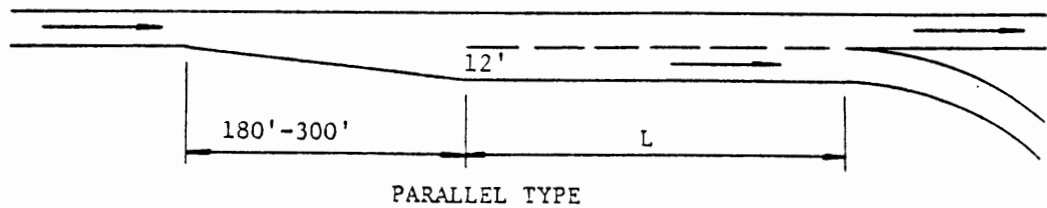

Recommended when design speed at exit curve is less than 50 MPH or when approach visibility is not good.

TABLE III-19

MINIMUM ACCELERATION LENGTHS FOR ENTRANCE TERMINALS

Highway Design Speed, mph	L = Acceleration Length - Feet								
	For Entrance Curve Design Speed, mph								
	Stop Condition	15	20	25	30	35	40	45	50
30	190	---	---	---	---	---	---	---	---
40	380	320	250	220	140	---	---	---	---
50	760	700	630	580	500	380	160	---	---
60	1,170	1,120	1,070	1,000	910	800	590	400	170
70	1,590	1,540	1,500	1,410	1,330	1,230	1,010	830	580

EXPRESSWAY ENTRANCE TERMINALS

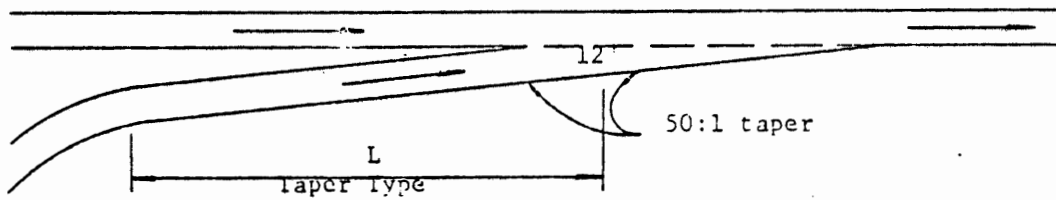

Recommended when design speed at entrance curve is 50 MPH or greater

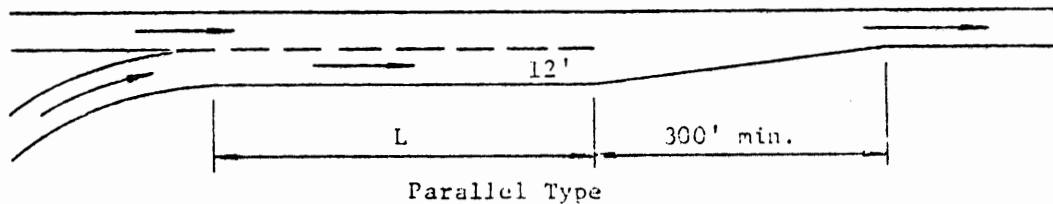

Recommended when design speed at entrance curve is less than 50 MPH

Entrances to freeways should be designed in accordance with the general configurations shown below Table III-19. Special care should be taken to ensure that vehicles entering from loops are not directed across the through travel lanes. The entering roadway should be brought parallel (or nearly so) to the through lanes before entry is permitted. Where acceleration is required the distances shown in Table III-19 shall, as a minimum, be provided. Exits and entrances to all high-speed (design speed greater than 50 mph) facilities should, where feasible, be designed in accordance with Tables III-18 and III-19. The lengths obtained from Tables III-18 and III-19 should be adjusted for grade by using the ratios in Table III-17.

The selection of the type and exact design details of a particular interchange requires considerable study and thought. The guidelines and design details given by current AASHO publications should generally be considered as a minimum criteria.

#### h. Clear Zone

The provisions of ample clear zone and/or proper redirection of energy-absorbing devices is particularly important at intersections. Every effort should be made to open up the area around the intersection to provide adequate clear zone for vehicles which have left the traveled way. Drivers frequently leave the proper travel path due to unsuccessful turning maneuvers or due to the necessity for emergency avoidance maneuvers. Vehicles also leave the roadway after intersection collisions and roadside objects should be removed to reduce the probability of secondary impacts. The roadside areas at all intersections and interchanges should be contoured to provide shallow slopes and gentle changes in grade.

The roadside clear zone of intersecting roadways should be carried throughout intersections with no discontinuities or interruptions. Poles and support structures for light, signs and signals should not be placed in medians or within the roadside clear zone. When light poles and signs must be placed within the clear zone they shall be clearly of the breakaway type.

The design of guardrails or other barriers should receive particular attention at intersections. Impact attenuators should be used in all gore and other areas where structures cannot be removed. Barrier curbs should not be used in intersections.

Particular attention should be given to the protection of pedestrians in intersection areas (see Section VIII PEDESTRIAN TRAFFIC). Further criteria and requirements for clear zone and protection devices at intersections are given in Section IV ROADSIDE DESIGN.

## 10. Other Design Factors

### a. Pedestrian and Bicycle Facilities

Provisions for expected pedestrian and bicycle traffic should be incorporated in the original highway design. All new highways, except controlled access highways, should be designed and constructed under the assumption that they will be used by bicyclists. Roadway conditions should be favorable for bicycling. This includes safe drainage grates and railroad crossings, smooth pavements, and signals responsive to bicycles. In addition, the desirability of adding facilities such as bicycle lanes, bicycle routes, shoulder improvements, and wide curb lanes should be included to the fullest extent possible. Specifically, all rural arterial and collector sections within one mile of an urbanized area should be given consideration for the construction of 4' paved shoulders, and all urban arterial and collector sections should be given consideration of either a 14' wide curb lane, undesignated 4' lane or marked bike lane. Generally such facilities shall not be marked to attract bicycle traffic. Pedestrian pathways should be separated from the roadway as far as is practical. Further criteria for the location of pedestrian and bicycle facilities are given in Section VIII PEDESTRIAN TRAFFIC, Section II LAND DEVELOPMENT and Section IX BICYCLE FACILITIES.

The placement of sidewalks adjacent to the roadway should be avoided wherever possible. If pedestrian paths or sidewalks are near the roadway the use of protective devices (see Section IV ROADSIDE DESIGN) should be considered where practical. Intersections of pedestrians and vehicle paths should be carefully designed with regard to providing adequate mutual sight distance. Pedestrian overpasses should be used where crossing volumes are high. These overpasses should have sufficient vertical clearance due to the potential consequences of being struck by a vehicle. Pedestrian overpasses should also be covered with a screen or other device to reduce the likelihood of objects being thrown onto passing vehicles.

### b. Utilities

Where it is necessary for the utility to locate within the highway, street or road, the placement and location shall not be in contradiction to or fail to meet the intent of the design requirements of this manual.

Poles or other above ground utility structures are not generally permitted in medians or within the roadside clear zones. Underground utilities should not be buried under the pavement when other space is available within the right of way. Unavoidable crossings of the roadway should be designed to allow for repairs and modifications without unnecessary disruption or hazard to traffic. The placement of access manholes within the pavement, shoulders, or medians should be avoided.

The location of all utilities should be selected so that it does not provide a roadside hazard and so that repairs and modifications can be performed without unnecessary disruption or hazard to traffic or workmen (see Section XI WORKSITE SAFETY). Further guidelines for utility control are presented in the Utility Accommodations Guide of the Florida Department of Transportation.

c. Drainage

The primary objective is to provide for rapid drainage of the roadway surface. Water standing on the travel lane or shoulder produces a definite safety hazard. It is also important to provide effective drainage for medians and roadside clear zones. Criteria used in drainage design can be found in the Florida Department of Transportation Drainage Manual.

The use of barrier curbs immediately in front of guardrails, bridge railings or other barriers is prohibited.

Drainage grate selection should consider bicyclist usage.

d. Traffic Control Devices

The design and layout of signs, signals, and markings should be carried out in conjunction with the original highway design. This is of particular importance at intersections. The design of the highway should, however, be sufficient within itself to provide the maximum clarity and control without reliance upon traffic control devices to remedy basic defects in the highway design. Demand activated traffic signals should consider small vehicles such as motorcycles and bicycles. The design and layout of traffic control devices shall be in agreement with the Manual of Uniform Traffic Control Devices for Streets and Highways.

e. Curb Cut Ramps for the Physically Handicapped

Permanent curb cut ramps shall be provided at crosswalks at all intersections where curbs and sidewalks are constructed in order to give persons in wheelchairs and other handicapped persons safe access to crosswalks. Curb cut ramps shall be constructed to be in substantial conformance with the Uniform Federal Accessibility Standards published by the General Services Administration, Department of Housing and Urban Development, Department of Defense, and United States Postal Service.

Ramp width shall be a minimum 3 feet wide with a 12:1 curb transitions on each side when pedestrians must walk across the ramp. The ramp slope shall not exceed 12:1 and shall have a slip-resistant surface texture.

For the safety of persons using the curb ramp, it should be placed within the crosswalk. It is important to blind persons using the sidewalk that the location of ramps be as uniform as possible. A contrasting surface texture should be used.

Designers should keep in mind that the many variables invoked make each street intersection a special problem. For this reason, standard guidelines will not fit all situations and cannot replace the need for the use of sound engineering judgement in the design of curb ramps.

f. Bridge Design Loadings

The minimum design loading for all new and reconstructed bridges shall be HS-20. "See AASHTO Standard Specifications for Highway Bridges."

g. Dead-end Streets and Cul-de-sacs

The end of a dead-end street should permit travel return with a turn around area, considering backing movements, that will accommodate single unit truck vehicles without encroachment upon private property. Recommended treatment for dead-end streets and cul-de-sacs is given in AASHTO ("A Policy on Geometric Design of Highways and Streets, 1984".)

h. Bus Benches and Transit Shelters

Any bus bench or transit shelter located on a sidewalk within the rights-of-way of any road on the State Highway or County Road System shall be located so as to leave at least 36 inches clearance for pedestrians and persons in wheelchairs. Such clearance shall be measured in a direction perpendicular to the centerline of the road.

11. Reconstruction

a. Introduction

A large portion of the existing highway network is obsolete. The reconstruction (improvement or upgrading) of existing facilities may generate equal or greater safety benefits than similar expenditures for the construction of new streets and highways. Modifications to increase capacity should be evaluated for the potential effect on the highway safety characteristics. The long-range objectives should be to bring the existing network into compliance with current standards.

b. Evaluation of Streets and Highways

The evaluation of the safety characteristics of streets and highways should be directed towards the identification of undesirable features on the existing system. Particular effort should be exerted to identify the location, and nature of features with a high accident potential. Methods for identifying and evaluating hazards include the following:

1. Identification of any geometric design feature that is not in compliance with minimum or desirable standards. This could be accomplished through a systematic survey and evaluation of existing facilities.



2. Information from maintenance or other personnel.

3. Review of accident records and traffic counts to identify locations with a large number of accidents or a high accident rate.

c. Priorities

A large percentage of highway reconstruction and improvement is, of course, directed toward increasing efficiency and capacity. The program of reconstruction should, however, be based to a large extent upon priorities for the improvement of safety characteristics.

The priorities for safety improvements should be based upon the objective of obtaining the maximum reduction in accident potential for a given expenditure of funds. Elimination of conditions that may result in serious or fatal accidents should receive the highest priority in the schedule for reconstruction.

Specific high priority problem areas that should be corrected by reconstruction include the following:

1. Obstructions to sight distance which frequently produce extremely serious hazards and can often be economically corrected. The removal of vegetation, poles, signs and parked vehicles to improve sight distances on curves and particularly at intersections can be of immense benefit in reducing accidents. The purchase of required line-of-sight easements is often a wise expenditure of highway funds. The establishment of sight distance setback lines is encouraged.

2. Roadside and median hazards which can often be removed or relocated farther from the traveled way. Where removal is not feasible, objects should be protected by redirection or energy-absorbing devices. The reduction of the roadside hazard problem generally provides a good return on the safety dollar. Details and priorities for roadside hazard reduction, which are presented in Section IV ROADSIDE DESIGN, should be incorporated into the overall priorities of the reconstruction program.

3. Poor pavement surfaces which are hazardous should be maintained or reconstructed in accordance with the design criteria set forth in Section V PAVEMENT DESIGN, CONSTRUCTION AND MAINTENANCE.

4. Specific design features which could be applied during reconstruction to enhance the operations and safety characteristics of a roadway include the following:

a) The addition of roadway lighting.

b) The provision of frontage roads or other alternate paths. This may be utilized to improve the efficiency and safety of streets and highways with poor control of access.

c) Widening of pavements and shoulders. This is often an economically feasible method of increasing capacity and reducing traffic hazards. Provision of median barriers (see Section IV ROADSIDE DESIGN) can also produce significant safety benefits.

d) The removal, streamlining, or modification of drainage structures.

e) Alinement modifications. These are usually extensive and require extensive reconstruction of the roadway. Removal of isolated sharp curves is a reasonable and logical first step in alinement modification. If major realignment is to be undertaken, every effort should be made to bring the entire facility into compliance with the requirements for new construction.

f) The use of traffic control devices. This is generally an inexpensive method of alleviating certain highway defects.

g) Existing bridges that fail to meet current design standards, and which are available to bicycle traffic, should be retrofitted on an interim basis as follows: As a general practice, bridges 125 feet in length or longer, bridges with unusual sight problems, steep gradients (which require the cyclist longer time to clear the span) or other unusual conditions should display the standard W11-1 Caution sign with an added slug "On Bridge" at either end of the structure. Special care should be given to the right most portion of the roadway, where bicyclists are expected to travel, assuring smoothness, pavement uniformity, freedom from latitudinal joints, and to ensure cleanliness. Failure to do so forces bicyclists further into the center portion of the bridge, reducing traffic flow and safety.

## SECTION IV: ROADSIDE DESIGN

### A. Introduction

This section presents guidelines and standards for roadside design that are intended to reduce the likelihood and/or consequences of roadside crashes. The construction and maintenance of safe medians and roadsides is of vital importance in the development of safe streets and highways.

Many of the standards presented in Section III GEOMETRIC DESIGN are predicated to a large extent upon reducing the probability of vehicles leaving the proper travel path. Other standards in that section are directed toward a reduction in the likelihood or consequences of crashes by vehicles that leave the roadway. These standards contain requirements for the design of shoulders, medians and roadside clear zone including requirements for the use of guardrail and median barriers. The design of the roadside should be considered and conducted as an integral part of the total highway design.

Due to the variety of causative factors, the designer should consider a vehicle leaving the traveled way at any location. The design of the roadside should be based upon reducing the consequences to errant vehicles and their occupants.

### B. Policy

The roadside, which includes the median, shall be considered as the total environment adjacent to the roadway. The design of the roadside shall be considered as an integral part of the total highway design.

### C. Objectives

The general objective to be followed in roadside design is to provide an environment that will reduce the likelihood and/or consequences of crashes by vehicles which have left the traveled way. The achievement of this general objective will be aided by the following:

1. Roadside areas that are adequate to allow reasonable space and time for a driver to regain or retain control of the vehicle and stop or return to the traveled way.
2. Shoulders, medians and roadside clear zones that may be traversed safely without overturning.
3. The location of roadside objects and hazards as far from the travel lane as is economically feasible.
4. Roadsides that, in addition to being safe, appear safe to the driver so as to encourage use of the roadside for necessary emergency avoidance maneuvers and for emergency parking.

5. Protection of pedestrians, workmen or other persons that may be subjected to the hazard of out-of-control vehicles.

6. Adequate protective devices (where hazards are unavoidable) that are compatible with vehicle speeds and other design variables.

#### D. Roadside Design

The basic requirements and standards for the design of shoulders, medians and roadside clear zones are given in Section III GEOMETRIC DESIGN. This includes specific requirements regarding widths, slopes and changes in grade. Also included are general requirements for drainage facilities, utilities and pedestrian pathways.

The contents of this chapter contain general guidelines for particular situations encountered in roadside design due to the variety and complexity of the possible situations that may be encountered. The designer should utilize the following as basic guidelines to develop a safe roadside design.

##### 1. Geometric Changes

###### a. Horizontal Curves

On horizontal curves, consideration should be given to increasing the median and roadside clear zone over the minimum requirements, due to the increased likelihood of vehicles leaving the traveled way. Increasing widths and decreasing slopes on curves is also important since a vehicle will probably leave the traveled way at a steeper exit angle. Increasing widths on curves is also beneficial in improving the available sight distance.

###### b. Vertical Curves

Additional roadside clear zones should be considered on steep grades and on crest vertical curves. As a vehicle comes over a crest the driver may suddenly be presented with a situation that requires an emergency avoidance maneuver. The provision of adequate clear zones beyond crests is particularly important where traffic volumes are high (e.g. urban areas) since traffic queues may form rapidly, thus tending to cause rear-end collisions.

###### c. Changes in Cross Section

The provision of adequate clear zone is very important at exits, entrances, lane drops or other changes in the roadway cross section. The exterior boundaries of the clear zone should be extended well beyond any reductions in roadway width and then gradually reduced to provide the design width for the new roadway cross section.

#### d. Decision or Conflict Points

Additional clear zones should be considered at any point of traffic merging or conflicts and at locations where the driver is confronted with making a decision regarding vehicle maneuvers.

#### 2. Fills

Most roadways are, for drainage purposes, elevated somewhat above the surrounding terrain. Where feasible, the side slopes should not exceed a ratio of 6:1. On shallow slopes (6:1 or flatter) care should be exercised to eliminate sharp changes in grade or other discontinuities.

If the side slope is steeper than 3:1 guardrail or another longitudinal barrier should be used. Where barriers are used the embankment slope should be determined, by taking into account soil stability considerations and maintenance.

#### 3. Cuts

A primary objective of roadside design in cut sections is to prevent conditions that would tend to cause rollovers or serious collisions with the cut embankment. When the material in the cut is smooth and stable the use of an increasing backslope is a reasonable solution. The technique is also acceptable in rock cuts that are stable provided that smooth fill material is utilized to effect the backslope.

The use of a rigid barrier incorporated into the cut slope is also satisfactory for rock slopes. Where the material in the cut is unstable, a guardrail or other longitudinal barrier set out from the cut face should be utilized. Placing the barrier away from the slope is necessary to prevent rocks or other material from falling onto the roadside clear zone.

#### 4. Roadside Canals

Roadside canals or other bodies of water close to the roadway should be avoided wherever possible.

Where roadside bodies of water at or near the boundary of the roadside clear zone cannot be avoided, they shall be guarded by a longitudinal barrier.

#### 5. Vegetation

The proper use of natural vegetation can provide valuable and economical assistance in developing safe roadsides.

a. Stability

The use of grass or other low-growing vegetation that is easily maintained may be used on medians and roadside clear zones. This vegetation should be carefully maintained so that a vehicle can safely traverse those areas.

b. Drainage

Drainage swales may be protected from hazardous scouring (alteration of safe ditch contour) by the appropriate vegetation. Grass, vines or other plants can be beneficial in stabilizing embankments to prevent erosion of material onto adjacent roadways. The appropriate use of grass or shrubbery can also aid in retarding runoff in the vicinity of the roadway, thus benefiting the overall drainage pattern.

c. Crash Cushion

Native shrubbery may also be used as an effective natural barrier or crash cushion at the outer edge of the clear roadside clear zone. Care should be taken to use shrubbery or other vegetation that would slow an out-of-control vehicle without excessive deceleration. Vegetation that would develop large trunks or branches should be avoided.

d. Environmental and Aesthetic Considerations

The use of natural grass and shrubbery for borders along roadways provides an important environmental asset. This border serves as a preserved green belt that minimizes the adverse impact (dirt, noise, etc.) of a street or highway. The use of a wide, gently flowing grassed roadside of varying width is generally an aesthetically pleasing solution to safe roadside design.

6. Drainage

Proper drainage of the pavement, shoulders, median and roadside clear zone is important for maintaining a safe street or highway. The techniques utilized for providing drainage should result in safe vehicle operation on or off the roadway.

a. Inlets

Drainage inlets should not be placed in a travel lane and should not be placed in a shoulder, except at the exterior edge when drainage restrictions are severe. Drainage inlets within the median or roadside clear zone should be flush with the ground surface. A small area around the inlet should be paved to improve drainage and to prevent local erosion.

b. Ditches

Drainage ditches perpendicular to the roadway should not be used within the median or roadside clear zone. Roadside drainage ditches (parallel to the roadway) should, whenever possible, be located outside of the required roadside clear zone. All drainage ditches within the median or roadside clear zone shall meet the requirements for slope and changes in grade given in Section III GEOMETRIC DESIGN.

c. Culverts

A primary objective of drainage design should be to eliminate open culverts and drainage structures, wherever possible. At intersections, exits, entrances, driveways and median crossovers, the drainage flow pattern should, if possible, be directed away from the interruption of the median or roadside clear zone.

Where culverts are unavoidable at intersections, the entrance and exit should be flush with the adjacent ground or located beyond the clear zone. The slope and changes in grade at the structure should conform to minimum requirements for roadside clear zone. Culvert terminations at median crossovers should be constructed in a similar fashion.

Where culverts are required perpendicular to the roadway, they should be extended beyond the roadside clear zone as far as is feasible. Headwalls at the culvert terminations (even outside the required clear zone) should not protrude above the ground surface. Sloping entrances and exits that are generally flush with side slopes should be used wherever possible. Proper ground contouring of the roadside approach can provide a relatively smooth surface that can be traversed with reasonable safety by an out-of-control vehicle.

7. Curbs

The basic criteria for prohibiting or permitting the use of curbs is given in Section III GEOMETRIC DESIGN. Curbs may be classified according to their function as a barrier, a delineation or a drainage control curb.

a. Barrier Curb (Any curb with a height greater than 6")

A barrier curb is utilized to deter access to the adjacent property. Barrier curbs should only be used outside of the clear zone when speeds are greater than 40 mph.

b. Drainage Control Curbs

On high-speed facilities every effort should be made to avoid the use of drainage curbs. In all cases the height of the curb shall be kept to a minimum necessary for drainage control purposes. On fills or

steep slopes drainage gutters may be required. The termination of all curbs should be effected by a gradual longitudinal taper with a slope of 6:1 or flatter.

#### 8. Poles and Support Structures

The location and design of poles or support structures for signs, signals, lighting, utilities or other purposes is one of the most important aspects of safe roadside design. All poles and support structures should be located outside of the required clear zone, unless they are clearly of the breakaway type, or are guarded by adequate protective devices.

Utility poles and structures not related to the highway operation should be located outside the recovery area or at the right of way line. Sign, signal and lighting supports should be set back as far as is practical.

Small breakaway signs may be used in clear zone if they are necessary for traffic control purposes.

#### 9. Intersections

Due to the high accident probability and the limited area involved, additional roadside clear zone should be considered at intersections. All poles or other structures that are not absolutely essential should not be located in the vicinity of the intersection. When joint use agreements can be arranged, the various governmental agencies and utilities should consider the use of joint purpose single poles as a replacement for all poles or structures that serve a single purpose. Light poles and traffic signal supports should be moved back as far as is practical from the boundary of the roadside clear zone.

Energy-absorbing devices should be considered for protection of lighting and traffic signal supports that are located near the roadside clear zone.

#### 10. Underpasses

The full median and roadside clear zone should be carried through the underpass without interruption. Where it is not feasible to eliminate the supports, guardrail or another longitudinal barrier should be used. The barrier may be a rigid barrier incorporated into the support columns or a guardrail set out from the supports. The barrier should be extended well beyond the supports.

#### 11. Bridges and Overpasses

The required horizontal clearance (see Section III GEOMETRIC DESIGN) should be maintained on all bridges, overpasses or other elevated roadways. The full roadway cross section, including shoulders, should be



carried across without interruption. Bridge railings should be designed and constructed in compliance with the requirements for redirection barriers. Particular emphasis should be placed upon the prevention of structural failure and vaulting of the railing by errant vehicles.

On all high speed roadways (design speed 50 mph or greater) the bridge railing or other barrier should be extended sufficiently (and properly terminated) to prevent vehicles from passing behind the barrier and entering the hazardous location. The transition between the bridge railing and the approach barrier should be smooth and continuous. Barrier curbs should not be placed in front of bridge railing or other barriers. Pedestrian pathways or sidewalks should be placed outside of the bridge railing or barrier on all high speed roadways.

It is desirable that twin bridges for nominal width median divided highways be filled in the dividing area, thus carrying the median across the bridge without interruption. The gore area between diverging elevated roadways should be bridged over for a sufficient distance to allow for the placement of any energy absorbing device. If twin bridges are used, the median layout should conform to Section III GEOMETRIC DESIGN.

## 12. Mailboxes

Guidelines for the location of mailboxes, type of support, and turnout construction are given in AASHTO (A Guide for Erecting Mailboxes on Highways - 1984).

## E. Protective Devices

Protective devices for roadside design may be considered as highway appurtenances that are intended to reduce the severity of off-the-roadway crashes. In those situations where the minimum safety standards for median and roadside clear zone are not feasible, protective devices should be used. These protective devices may be divided into three general categories, namely redirection devices, energy absorbing devices and breakaway supports.

### 1. Redirection Devices

Redirection devices are longitudinal barriers (rigid or flexible) such as guardrails, median barriers and bridge railings that are placed parallel to the roadway to contain out-of-control vehicles.

#### a. Function

The primary function of a longitudinal barrier is to redirect an errant vehicle away from hazardous roadside situations. The barrier should be designed to produce a minimum of deceleration (lateral and longitudinal) to a vehicle.

b. Warranting Conditions

Warranting conditions for the use of longitudinal barriers are essentially those conditions in which the overall probability of injuries and fatalities would be reduced by the use of these redirection devices.

c. Location

Ideally, the barrier should be located so as to minimize the likelihood of its being struck by an errant vehicle. The barrier should be located outside the normal shoulder width. The location and orientation of the barrier should also be selected to minimize the angle of impact and thus the resulting vehicle deceleration.

Flexible barriers should be set out from rigid objects or other hazards a sufficient distance so that the barrier may deflect without interference. Reasonable deflections for guardrails with strong posts are approximately 2 to 4 feet. Weak posts/strong rail barriers and cable systems may deflect considerably more. The location of the barrier should be selected in close coordination with the design of its deflection characteristics.

d. Length

The length of a longitudinal barrier should be sufficient to prevent a vehicle, travelling in either direction, from passing behind the barrier and striking the hazard being guarded.

e. Vehicle Containment

Longitudinal barriers should have sufficient strength to prevent a vehicle from breaking through the barrier. Structural continuity and smoothness is also required to prevent rapid deceleration or penetration of the vehicle by any of the barrier components. The shape and height of the barrier should be adequate to discourage overturning or vaulting of the barrier. The surface in front of the barrier should be approximately perpendicular to the barrier and should be free from barrier curbs or other discontinuities.

f. Barrier Types

Barriers may be generally classified as rigid or flexible. The recommended barriers in the following material are intended as general guidelines only. As new types of barriers are developed and tested successfully, they may be incorporated into roadside design. They should, however, conform with the requirements previously established.

### 1) Rigid Barrier

Rigid barriers are generally less effective in controlling lateral vehicle decelerations at locations subject to high-angle impacts. The use of this barrier is recommended for bridge railings and for use at retaining walls, rock cuts or other rigid hazards where space limitations are severe.

### 2) Flexible Barriers

Barriers which yield somewhat on impact are often more useful in limiting vehicle decelerations. Special care should be exercised to ensure that they are structurally adequate and that they maintain a smooth continuous surface.

This type of barrier can be expected to deflect 2 to 4 feet under impact. The post spacing may be increased when a stiffer rail is utilized. The weak post barrier and the cable barrier can be expected to deflect 8 to 12 feet or more and should be limited to locations with adequate clear space.

#### g. Transitions

Changes in barrier type should be kept to a minimum. Transitions between barriers of two types should be smooth and continuous with no protruding components that could snag or penetrate a vehicle striking the barrier from either direction. The transition from a flexible to a rigid barrier should be stiffened gradually to prevent "pocketing" of an errant vehicle.

#### h. Terminations

Barrier terminations or interruptions should be kept to a minimum. The barrier termination should be designed to allow for a reasonably safe traversal by a vehicle travelling in either direction.

Roadside guardrails should be flared away from the roadway. The use of energy absorbing device as the termination of the longitudinal barrier is an effective and acceptable procedure for both roadsides and medians.

## 2. Energy-Absorbing Devices

### a. Function

The primary function of an energy-absorbing device or crash cushion is to limit the deceleration rate of a vehicle. This is utilized at locations where impact with the roadside object would produce a greater deceleration rate. The deceleration rate is controlled by providing a cushion which deforms over a large distance while bringing the vehicle gradually to a stop.

b. Warranting Conditions

Crash cushions (or other protective devices) are used for the protection of occupants of an out-of-control vehicle which might strike objects in the median or roadside clear zone that would produce serious vehicle deceleration.

Other locations or situations that should be considered for crash cushions include: gore areas on elevated roadways, intersections, barrier terminations, bridge abutments and supports, retaining walls, or any other roadside object subject to impact by an errant vehicle.

c. Design Criteria

The primary design criteria is the limitation of vehicle deceleration which is a function of the vehicle speed and the total crash cushion deformation.

The crash cushion should be located as far from the roadway as is practicable to reduce the likelihood of impact. Special care should be exercised in the design to reduce the probability of a vehicle overturning or vaulting the crash cushion.

d. Design Details

The development and testing of crash cushions are both recent and rapid. The rapidly expanding technology in this field requires that the most recent research and experience be utilized in selecting a particular type of crash cushion.

3. Breakaway Supports

Where unprotected poles or supports for signs, signals, lighting or other purposes are located in the median or roadside clear zone they should be breakaway in nature. The function of a breakaway support is to minimize the vehicle deceleration and thus the probability of injury to the vehicle occupants. The design of the support should also be adequate to prevent portions of the structure from penetrating the vehicle interior.

Small signs should be designed to bend over flush with the ground upon impact. Larger signs should be designed with multiple posts with slip joints at the base and a weakened section and fuse plate intended to act as a hinge at the bottom of the sign.

## SECTION V: PAVEMENT DESIGN, CONSTRUCTION AND MAINTENANCE

### A. Pavement Design

The functions of the pavement or roadway surface is to provide a safe and efficient travel path for vehicles using the street or highway. The pavement should provide a uniform contact surface between the vehicle and the roadway, thus allowing for a comfortable ride and a minimum of distractions to the driver. The pavement friction characteristics should be such that adequate longitudinal and lateral forces between the vehicle tires and the pavement can be developed to allow an adequate margin of safety for required vehicle maneuvers. These characteristics should prevail at the highest reasonable level for the expected surface and weather conditions and anticipated operational characteristics of the facility.

In order for the pavement to perform its function properly, the following objectives shall be followed in the design and construction of the pavement:

- 1) Develop and maintain adequate skid resistance qualities to allow for safe execution of braking, cornering, accelerating and other vehicle maneuvers.
- 2) Provide drainage to promote quick drying and to reduce the likelihood of hydroplaning and splashing.
- 3) Provide sufficient structural integrity and the proper rigidity to prevent ravelling, breakup, rutting and "potholing".

#### 1. Skid Resistance

The development of adequate skid resistance properties shall be a major factor in the design and construction of pavements. Pavements should be designed and constructed so as to maintain adequate skid resistance for as long a period as the available materials, technology, and economic restraints permit, thus eliminating many costly and hazardous maintenance operations. The use of steel grid bridge decks should be avoided except for movable or temporary spans. A durable, skid-resistant surface texture should be incorporated in the pavement to allow for adequate friction capabilities between the vehicle tires and the roadway surface. The surface texture should be coarse (deep textured and angular), gritty, and resistant to polishing and breakup. Due to the complexity of pavement design and construction, the results of relevant experience and testing (such as that conducted by the Florida Department of Transportation Bureau of Materials and Research) should be used in the selection of aggregate and other materials, the general mix design, the method of placement and the techniques used for finishing the pavement surface. The design of mixes should be modified by continuous field test during construction and should be entrusted to qualified pavement designers and laboratory personnel only.

## 2. Drainage

Adequate drainage of the roadway and shoulder surfaces should be provided to prevent accumulation of water to excessive depths. Factors involved in the general pavement drainage pattern include the pavement tangential and cross slopes, shoulder slopes and surface texture, curb placement and the location and design of collection structures. The selection of pavement cross slopes should receive particular attention to achieve the proper balance between drainage requirements and vehicle operation requirements. The use of curbs or other drainage restrictions adjacent to the roadway surface should be avoided, particularly on high speed facilities. Specific requirements for cross slopes and curb placement are given in Section III GEOMETRIC DESIGN. The use of grooving (parallel to the roadway) in concrete pavements frequently improves the wet-weather skid resistance and decreases likelihood of hydroplaning. This technique should be considered for locations requiring frequent vehicle maneuvers (curves, intersections, etc.) or where heavy traffic volumes or high speeds will be encountered. The depth, width and spacing of the grooves should be such that vehicle operations are not hindered.

## 3. Structural Integrity

The pavement shall be designed and constructed so that the required pavement surface texture is maintained and the pavement does not rapidly ravel, breakup or spall. The rigidity of the pavement shall be sufficient to maintain its designed contour without the formation of ruts or other depressions which would impede good drainage. Transverse and longitudinal joints in concrete pavements should normally be equipped with load transfer devices to prevent excessive separation, settlement discontinuities or "pumping" at the joints. The strength of the pavement shall be sufficient to prevent early breakup or "potholing". The subgrade for any type of pavement (rigid or flexible) is a major factor in the assurance of the integrity of the pavement. The current versions of the Florida Department of Transportation Manuals (Flexible Pavement Design Manual and Flexible Pavement Rehabilitation) are recommended as a guide for flexible pavement design.

The AASHTO Interim Guide for Design of Pavement Structures 1972, Chapter III Revised 1981, is utilized by the Department for rigid pavement design. Design procedures such as those documented in "Thickness Design for Concrete Pavements" published by the Portland Cement Association and the "Municipal Concrete Pavement Manual, Guide Specifications and Design Standards" published by the American Concrete Pavement Association may be applicable. The selection of the design procedure and the development of design data must be managed by professional personnel competent to make these evaluations.

## B. Pavement Construction

A regular program of inspection and evaluation should be conducted to ensure that the pavement criteria are satisfied during the construction process. Any regular inspection program should include the following elements:

- 1). The use of standard test procedures, such as AASHTO and ASTM.
- 2). The use of qualified personnel to perform testing and inspection.
- 3). The use of an independent assurance procedure to validate the program.

After construction the pavement surface shall be inspected to determine that the required surface texture was achieved and that the surface is uniform with the specified slopes. Spot checking of skid resistance by approved methods should be considered. Inspection of the roadway during wet weather conditions should be carried out as soon as possible to quickly locate drainage problems such as depressions in the pavement surface. Periodic reinspections should be undertaken in conformance with the guidelines in D. Pavement Maintenance.

Rumble strips shall not extend closer than 18" from the outside edge of pavement. When such ridges (rumble strips) are carried to the outside edge of the pavement bicyclist are often forced to cross to the opposite side of the roadway, setting up a hazardous situation.

## C. Shoulder Treatment

The primary function of the shoulder is to provide an alternate travel path for vehicles in an emergency situation, and therefore, should be capable of providing a safe path for vehicles traveling at the roadway speed.

The shoulder should be designed and constructed to provide a firm and uniform surface, capable of supporting vehicles in distress. Particular attention should be given to providing a smooth transition from pavement to shoulder and avoiding hazardous "drop-offs".

## D. Pavement Maintenance

Although good pavement maintenance requires a substantial portion of the total maintenance budget for streets and highways, it is necessary to ensure highway safety. The provision of a smooth-riding, skid-resistant surface is necessary at all times to allow for safe vehicle maneuvers. The reduction of hydroplaning and splashing is essential for promoting safe and efficient operation during wet weather conditions. The elimination of driving discomfort, and vehicle damage encountered on deteriorated pavements, provides additional economic justification for maintaining the pavement in quality condition.

It is recognized that the quality program of pavement replacement, correction and improvement is very expensive and time-consuming. Adequate financing is, of course, required to successfully carry out this maintenance program. The establishment of appropriate budget priorities and careful planning can assist in developing and conducting a pavement maintenance program that will, within a reasonable number of years, bring sub-standard pavements up to the required quality.

The primary purpose of pavement maintenance is to ensure that the pavement characteristics prescribed in Pavement Design and Pavement Construction are reasonably maintained.

Each agency with responsibility for maintenance of streets and highways should establish and maintain a meaningful program of pavement maintenance (including shoulders and drainage structures) for the entire system under its jurisdiction. This program should include:

1. Evaluation of existing streets and highways to identify inadequate pavement.
2. Establishment of a systematic plan with the proper priorities for replacement or correction of inadequate pavements.
3. Establishment of procedures for corrections and improvement of existing pavements that will result in satisfactory performance.
4. Establishment of a regular program of pavement replacement, correction and improvement.



## SECTION VI: ROADWAY LIGHTING

### A. Introduction

The major reason for lighting streets and highways is to improve safety for vehicular and pedestrian traffic. Improvements in sight distance and reduction of confusion and distraction for nighttime driving can reduce the hazard potential on streets and highways. There is evidence indicating that highway lighting will produce an increase in highway capacity as well as improve the economic, safety and esthetic characteristics of highways.

Experience and technical improvements have resulted in improved design of lighting for streets and highways. Photometric data provide a basis for calculation of the illumination at any point for various combinations of selected luminaire types, heights and locations. The lighting engineer can develop a lighting system that will comply with the requirements for level and uniformity of illumination; however, some uncertainties preclude the adoption of rigid design standards. Among these uncertainties is the lack of understanding in the area of driver response and behavior under various lighting conditions. The design of lighting for new streets and highways, as well as improvements on existing facilities, should be accompanied by careful consideration of the variables involved in driver behavior and problems peculiar to particular locations.

### B. Objectives

The objective for providing roadway lighting is the reduction of particular hazards confronting motorists and pedestrians on the roadway. The achievement of this objective will be aided by meeting these specific objectives:

1. Provide the driver with an improved view of the general roadway geometry and the adjacent environment.
2. Increase the sight distance of drivers to improve response to hazards and decision points.
3. Improve the mutual view of motorists and pedestrians.
4. Eliminate "blind" spots peculiar to night driving.
5. Provide a clearer view of the general situation during police, emergency, maintenance and construction operations.
6. Provide assistance in roadway delineation, particularly in the presence of confusing background lighting (e.g., surrounding street and other area lighting confuses the driver on an unlighted street or highway).
7. Eliminate glare that is discomforting or disabling to the driver.
8. Avoid abrupt changes in light intensity.

9. Provide maintenance capabilities and procedures that will minimize hazards to motorists.

10. Avoid the introduction of roadside hazards resulting from improper placement of light poles (as covered under geometric design and roadside design).

### C. Warranting Conditions

Although precise warrants for provision of roadway lighting are difficult to determine, criteria for lighting are established and should be followed for construction and for improvement of existing facilities. The following locations should be considered as a basis for warranting roadway lighting:

#### 1. Criteria based upon accident history:

a. Locations that, by an accident investigation program, have been shown to be hazardous due to inadequate lighting.

b. Locations where the night/day ratio of serious crashes is higher than the average of similar locations.

c. Specific locations that have a significant number of nighttime accidents and where a large percentage of these nighttime accidents result in injuries or fatalities.

#### 2. Criteria based upon analysis and investigation:

a. Locations that require a rapid sequence of decisions by the driver.

b. Locations where night sight distance problems exist with particular consideration to vehicle headlight limitations (e.g., where vertical and horizontal curvature adversely affect illumination by headlamps).

c. Locations that have discomforting or disabling glare.

d. Locations where background lighting exists, particularly if this could be distracting or confusing to the driver.

e. Locations where improved delineation of the roadway alignment is needed.

#### 3. General criteria:

a. Freeways, expressways and major streets and highways in urban areas.

- b. Freeways with frequent (1/2 mile from "on" ramp to "off" ramp) interchanges.
- c. Freeways with high volume and speed.
- d. Freeway interchanges including ramps and approach roadways.
- e. Acceleration and deceleration lanes.
- f. Rest areas.
- g. Junctions of freeways and major highways in rural areas.
- h. Urban collector streets, particularly with high speed, high volumes or frequent turning movements.
- i. Urban streets of any category that experience high nighttime volumes or speeds or that have frequent signalization or turning movements.
- j. Areas that are frequently congested with vehicular and/or pedestrian traffic.
- k. Pedestrian crossings.
- l. Schools, churches, bus stops or other pedestrian or bicycle generators.
- m. High density land use areas.
- n. Central business districts.

#### D. Level of Illumination

It is recommended that the level of illumination for streets and highways not be less than:

1. Levels consistent with need and resources.
2. Guidelines established by AASHO (An Informational Guide for Roadway Lighting - March 1969).

These levels are for the purpose of highway safety and do not apply to lighting levels required for crime reduction.

#### E. Uniformity of Illumination

In order to avoid vision problems due to varying illumination, it is important to maintain illumination uniformity over the roadway. It is recommended that the ratio of the average to the minimum initial illumination on the roadway be between 3:1 to 4:1. Where an average maintained illumination of less than 0.6 footcandle is indicated a 6:1 ratio applies.

A maximum to minimum uniformity ratio of 10:1 should not be exceeded. It is important to allow time for the driver's eye to adjust to lower light levels. The first poles should be located on the side of the incoming traffic approaching the illuminated area. The eye can more quickly adjust to increased or increasing light level. In transition from a lighted to an unlighted portion of the highways, the level should be gradually reduced from the level maintained on the lighted section. This may be accomplished by having the last pole occur on the opposite roadway. The roadway section following lighting termination should be free of hazards or decision points. Lighting should not be terminated before changes in background lighting, or roadway geometry, or at the location of traffic control devices.

#### F. Underpasses

One of the criteria to be followed to determine requirements for underpass lighting is the relative level between illumination on the roadway inside and outside of the underpass. The height, width, and length of the underpass determines the amount of light penetration from the exterior.

##### 1. Daytime Lighting

A gradual decrease in the illumination level from daytime level on the roadway to the underpass should be provided. Supplemental daytime lighting is normally not needed in underpasses less than 100 to 200 feet in length.

##### 2. Night Lighting

The nighttime illumination level in the underpass should be maintained near the nighttime level of the approach roadway. Due to relatively low luminaire mounting heights, care should be exercised to avoid glare.

#### G. Maintenance

A program of regular preventive maintenance should be established to ensure that levels of illumination do not go below required values. The program should be coordinated with lighting design to determine the maintenance period. Factors for consideration include a decrease in lamp output, luminaire components becoming dirty, and the physical deterioration of the reflector or refractor. The maintenance of roadway lighting should be incorporated in the overall maintenance program specified in Section X MAINTENANCE.

#### H. Light Poles

Light poles should not be placed so as to provide a hazard to out-of-control vehicles. Light poles are generally of a frangible or breakaway design and should be placed outside of the roadway recovery area or as far removed from the travel lane as possible, or behind adequate guardrail or other barriers. Light poles should be placed on the inside of the curves when feasible. Foundations or poles and rigid auxiliary lighting

components that are not behind suitable barriers should be constructed flush with or below the ground level. Breakaway or frangible poles should not be used where there is a high probability that a falling pole may strike a pedestrian, or fall on a building or the roadway and create a greater hazard.

The use of High Mast Lighting should be considered, particularly for lighting interchanges and other large plaza areas. This use tends to produce a more uniform illumination level, reduces glare and allows placement of the poles further from the roadway.

The placement of light poles should not interfere with the driver's sight distance nor the view of signs, signals or other traffic control devices. Further criteria regarding the placement of roadside structures, including light poles, is given in Section IV ROADSIDE DESIGN.



## SECTION VII: RAIL-HIGHWAY GRADE CROSSINGS

### A. Introduction

The basic design for grade crossings should be similar to that given for highway intersections in Section III GEOMETRIC DESIGN. Rail-highway grade crossings should be limited in number and should, where feasible, be accomplished by grade separations. Where at-grade crossings are necessary, adequate traffic control devices and proper crossing design are required to limit the probability of accidents.

### B. Objective and Priorities

The primary objective in the design, construction, maintenance and reconstruction of rail-highway crossings is to provide for continuous flow of traffic in a safe and efficient manner. The achievement of this objective may be realized by utilizing the following techniques in the listed sequence of priority.

#### 1. Conflict Elimination

The elimination of at grade rail-highway conflicts is the most desirable procedure for promoting safe and efficient traffic operations. This may be accomplished by the closing of a crossing or by utilizing a grade separation structure.

#### 2. Hazard Reduction

The design of new at-grade crossings should consider the objective of hazard reduction. In addition, an effective program of reconstruction should be directed towards reducing the accident potential at existing crossings.

The regulation of intersections between railroads and all public streets and highways in Florida is vested in the Florida Department of Transportation (Rule 14-46). It is the policy of the Department that each new grade crossing shall, as a minimum, be protected by flashing signals and bells at the crossing and other devices in accordance with the Manual on Uniform Traffic Control Devices for Streets and Highways and applicable Design Standards.

The priorities and standards for upgrading existing crossings are also specified by the Department of Transportation Highway Safety Improvement Program Manual.

### C. Design of Rail-Highway Grade Crossings

The primary requirement for the geometric design of a grade crossing is that it provide adequate sight distance for the motor vehicle operator to make an appropriate decision as to stop or proceed at the crossing.

## 1. Sight Distance

The sight distance requirements for streets and highways at rail-highway grade crossings are similar to those required for highway intersections (see Section III GEOMETRIC DESIGN). Additional sight distance should be provided since train traffic has little or no stopping capabilities.

### a. Stopping Sight Distance

The approach roadways at all rail-highway grade crossings should consider stopping sight distances no less than the values given in Table III-14 or Figure III-7 for the approach to stop signs. This distance shall be measured to a stopping point prior to gates or stop bars at the crossing, but not less than 15 feet from the nearest track. All traffic control devices shall be visible from the driver eye height of 3.50 feet.

### b. Visibility Triangle

At grade crossings without train activated signal devices, a visibility triangle should be provided.

The provision of the capability for defensive driving is an important aspect of the design of rail-highway grade crossings. An early view of an approaching train is necessary to allow the driver time to decide to stop or to proceed through the crossing.

The size of this visibility triangle, which is shown in Figure VII-1, is dependent upon the train speed limit, the highway design speed and the highway approach grade. The minimum distance along the highway ( $d_H$ ), includes the requirements for stopping sight distance, the offset distance (D) from the edge of track to the stopped position (15') and the eye offset ( $d_e$ ) from the front of vehicles (10'). (See Figure VII-1, Case 1.) The required distance ( $d_T$ ) along the track, given in Table VII-1, is necessary to allow a vehicle to stop or proceed across the track safely. Where the roadway is on a grade, the lateral sight distance ( $d_L$ ) along the Track should be increased as noted below Table VII-1. This lateral sight distance is desirable at all crossings. In other than flat terrain it may be necessary to rely on speed control signs and devices and to predicate sight distance on a reduced speed of operation. This reduced speed should never be less than 15 and preferably 20 mph.

### c. Crossing Maneuvers

The sight distance required for a vehicle to cross a railroad from a stop is essentially the same as that required to cross a highway intersection as given in Section III GEOMETRIC DESIGN.

An adequate clear distance along the track in both directions should be provided at all crossings. This distance, when used, shall be no less than the value obtained from Figure VII-1 and Table VII-1 (Case II). Due to the greater stopping distance required for trains, this distance should be increased wherever possible.



The crossing distance to be used shall include the total width of the tracks, the length of the vehicle, and an initial vehicle offset. This offset shall be at least 10 feet back from any gates or flashing lights but not less than 15 feet from the nearest track. The train speed used shall be equal to or greater than the established train speed limit.

The setback for determining the required clear area for sight distance (similar to that shown in Figure III-11) should be at least 10 feet more than the vehicle offset. Care should be exercised to ensure that signal supports and other structures at the crossing do not block the view of drivers preparing to cross the tracks.

## 2. Approach Alinement

The alinement of the approach roadways is a critical factor in developing a safe grade crossing. The horizontal and vertical alinement, and particularly any combination thereof, should be as gentle as possible.

### a. Horizontal Alinement

The intersection of a highway and railroad should be made as near to the right angle (90 degrees) as possible. Intersection angles less than 70 degrees should be avoided. The highway approach should, if feasible, be on a tangent, since the use of a horizontal curve tends to distract the driver from a careful observation of the crossing. The use of superelevation at a crossing is normally not possible, since this would prevent the proper grade intersection with the railroad.

### b. Vertical Alinement

The vertical alinement of the roadway on a crossing is an important factor in safe vehicle operation. The intersection of the tracks and the roadway should constitute an even plane. All tracks should, preferably, be at the same elevation, thus allowing a smooth roadway through the crossing. Where the railroad is on a curve with superelevation, the vertical alinement of the roadway shall coincide with the grade established by the tracks.

Vertical curvature on the crossing should be avoided. This is necessary to limit vertical motion of the vehicle.

The roadway approach to crossing should also coincide with the grade established by the tracks. This profile grade, preferably zero, should be extended a reasonable distance (at least two times the design speed in feet) on each side of the crossing. Where vertical curves are required to approach this section, they should be as gentle as possible. The length of these vertical curves shall be of sufficient length to provide the required sight distance.

### 3. Highway Cross Section

Preserving the continuity of the highway cross section through a grade crossing is important to prevent distractions and to avoid hazards at an already dangerous location.

#### a. Pavement

The full width of all travel lanes shall be continued through grade crossings. The crown of the pavement shall be removed gradually to meet the grade of the tracks. This pavement cross slope shall be removed in conformance with the requirements for superelevation runoff. The lateral and longitudinal pavement slopes should normally be designed to direct drainage away from the tracks.

#### b. Shoulders

All shoulders shall be carried through a rail-highway grade crossings without interruption. The use of full-width paved shoulders is required at all new crossings to maintain a stable surface for emergency maneuvers. The shoulders should be paved a minimum distance of 25 feet on each side of the crossing measured from the outside rail.

#### c. Medians

The full median width on divided highways should be continued through the crossing. The median should be contoured to provide a smooth transition on the tracks. The use of signs and roadside delineation is recommended to discourage use of the median to cross the tracks. Signals should be installed in the median only when gate arms of 38 feet will not adequately span the approach roadway.

#### d. Roadside Clear Zone

Although it is often not practical to maintain the full width of the roadside clear zone the maximum clear area feasible should be provided. This clear area shall conform to the requirements for slope and change in grade for roadside clear zones.

#### e. Auxiliary Lanes

Auxiliary lanes are permitted but not encouraged at signalized grade crossings that have a large volume of bus or truck traffic that is required to stop at all times. These additional lanes should be restricted for the use of these stopping vehicles. The approaches to these auxiliary lanes shall be designed as storage or deceleration lanes. The exits shall be designed as acceleration lanes. The requirements for shoulders and horizontal clearance shall be based upon a consideration of these lanes as normal travel lanes.

#### 4. Roadside Design

The general requirements for roadside design given in Section III GEOMETRIC DESIGN and Section IV ROADSIDE DESIGN should be followed at grade crossings. Supports for traffic control devices may be required within the roadside recovery area. Due to the structural requirements and the necessity for continuous operation, the use of a breakaway design is not recommended. The use of a guardrail or other longitudinal barrier is, also, not recommended, since an out-of-control vehicle would tend to be directed into the crossing.

In order to reduce the hazard to errant vehicles, all support structures should be placed as far from the roadway as is practicable.

#### 5. Access Control

The general criteria for access control (see Section III GEOMETRIC DESIGN) for streets and highways should be maintained in the vicinity of rail-highway grade crossings. Private driveways should not be permitted within 150 feet, and intersections within 300 feet, of any grade crossing.

#### 6. Parking

When feasible, no parking shall be permitted within the required clear area for the sight distance visibility triangle.

#### 7. Traffic Control Devices

The proper use of adequate advance warning and traffic control devices is essential for all grade crossings. Advance warning should include pavement markings and two or more signs on each approach. Each new crossing should be equipped with train-activated flashing signals. Gates when used should, ideally, extend across all lanes, but shall at least block one-half of the inside travel lane. Traffic Control devices shall be installed in agreement with the Manual of Uniform Traffic Control Devices for Streets and Highways.

#### 8. Rail-Highway Grade Crossing Surface

Each crossing surface should be compatible with highway user requirements and railroad operations at the site. When installing a new rail-highway crossing or reworking an existing at-grade crossing, welded rail should be placed the entire width from shoulder point to shoulder point.

#### 9. Roadway Lighting

The use of roadway lighting at grade crossings should be considered to provide additional awareness to the driver. Illumination of the tracks can also be a beneficial safety aid.

## 10. Crossing Configuration

A recommended layout for a simple grade crossing is shown in Figure VII-2. Although the design of each grade crossing must be "tailored" to fit the existing situation, the principles given in this section should be followed in the design of all crossings.

### D. Maintenance and Reconstruction

The inspection and maintenance of all features of rail-highway grade crossings shall be an integral part of each highway agency's and railroad company's regular maintenance program (see Section X MAINTENANCE). Items that should be given a high priority in this program include: pavement stability and skid resistance, clear sight distance and all traffic control and protective devices.

The vertical alinement of the approach roadway should be adjusted when rail elevations are raised to prevent abrupt changes in grade and entrapment of low clearance vehicles. See Section 316.170 of the Florida Statutes for road clearance requirements.

The improvement of all substandard or hazardous conditions at existing grade crossings is extremely important and should be incorporated into the regular highway reconstruction program. The objective of this reconstruction program should be to upgrade each crossing to meet these standards. The priorities for reconstruction should be based upon the guidelines set forth by the Department of Transportation.

Figure VII-1  
 VISIBILITY TRIANGLE AT RAILROAD CROSSINGS

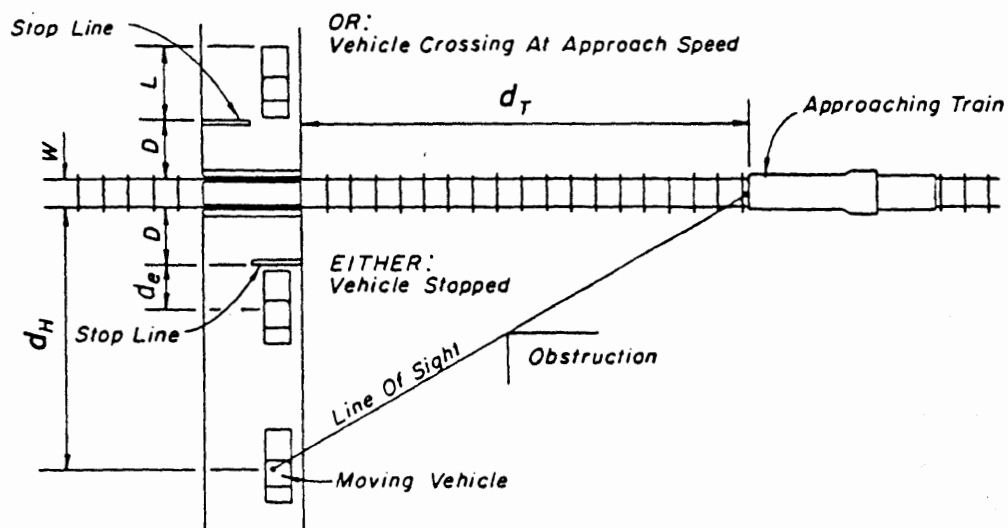

CASE I  
 APPROACHING VEHICLE TO SAFELY CROSS OR STOP AT RAILROAD CROSSING

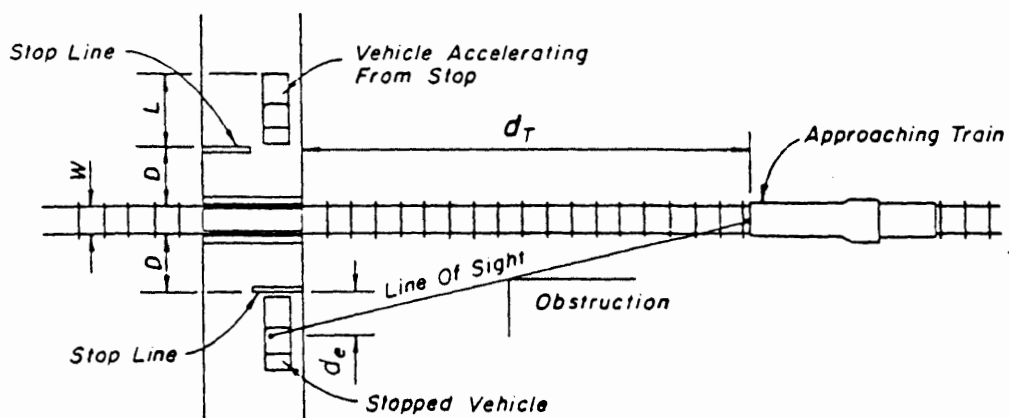

CASE II  
 VEHICLE DEPARTING FROM STOPPED POSITION TO SAFELY CROSS RAILROAD TRACK

For  $d_H$  and  $d_T$  values and crossing conditions see Table VII-1.

Table VII-1

SIGHT DISTANCE AT RAILROAD GRADE CROSSINGS

DESIGN SIGHT DISTANCES FOR COMBINATIONS OF TRAIN AND HIGHWAY VEHICLE SPEEDS CONDITIONS: SINGLE TRACK 90° CROSSING DESIGN VEHICLE WB-60 (L=65', d <sub>e</sub> =10') FLAT HIGHWAY GRADES NO TRAIN ACTIVATED WARNING DEVICES TRACK WIDTH (W) = 5' VEHICLE STOP POSITION (D) = 15'								
TRAIN SPEED MPH	CASE II VEHICLE DEPARTURE FROM STOP	CASE I MOVING VEHICLE						
	VEHICLE SPEED MPH							
	0	10	20	30	40	50	60	70
	d <sub>T</sub> (ft.) SIGHT DISTANCE ALONG RAILROAD TRACK							
10	240	145	103	99	103	112	122	134
20	480	290	207	197	207	224	245	269
30	719	435	310	296	310	337	367	403
40	959	580	413	394	413	449	489	537
50	1,199	725	517	493	517	561	611	671
60	1,439	870	620	591	620	673	734	806
70	1,679	1,015	723	690	723	786	856	940
80	1,918	1,160	827	789	827	898	978	1,074
90	2,158	1,305	930	887	930	1,010	1,101	1,209
d <sub>H</sub> (ft.) SIGHT DISTANCE ALONG HIGHWAY								
	95	150	225	350	500	675	875	

Sight distances are required in all quadrants of the crossing. Corrections must be made for conditions other than shown in the table, such as, multiple rails, skew, ascending and descending grades, and curvature of highway and rails. For condition adjustments and additional information refer to Railroad Grade Crossing under Chapter IX of "A Policy On Geometric Design Of Highways And Streets", AASHTO 1984.

FIGURE VII-2

GRADE CROSSING CONFIGURATION  
RURAL

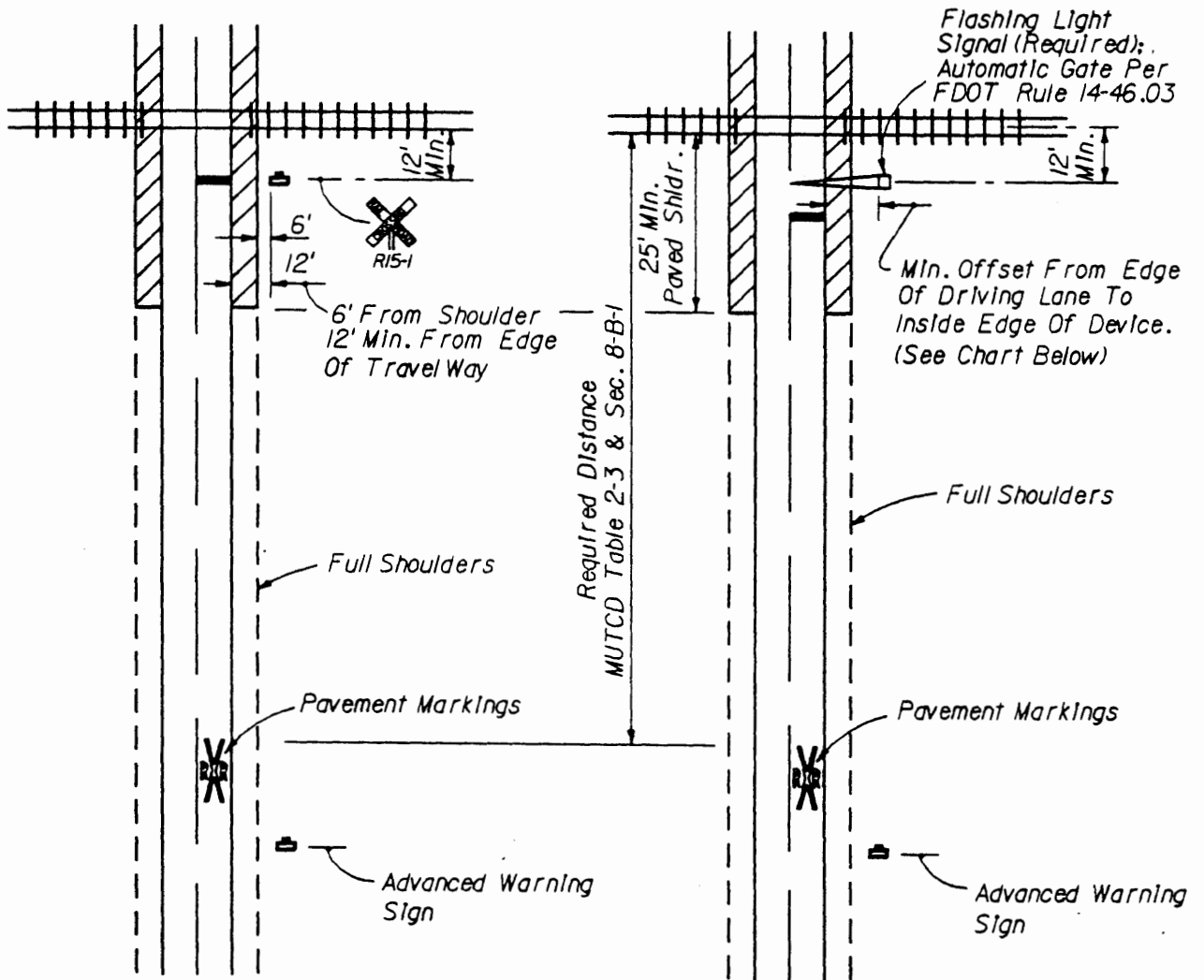

PASSIVE CROSSING

DESIGN SPEED	MIN. OFFSET
Less Than 35 MPH	6'
35 MPH - 45 MPH	8'
Greater Than 45 MPH	10'

ACTIVE CROSSING

FIGURE VII-3  
**MEDIAN SIGNAL GATES**  
**MULTI LANE UNDIVIDED URBAN SECTIONS**  
*( Four Or More Driving Lanes In One Direction )*  
**45 M.P.H. OR LESS**

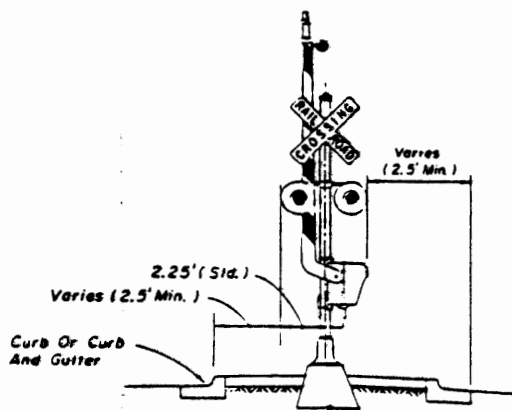
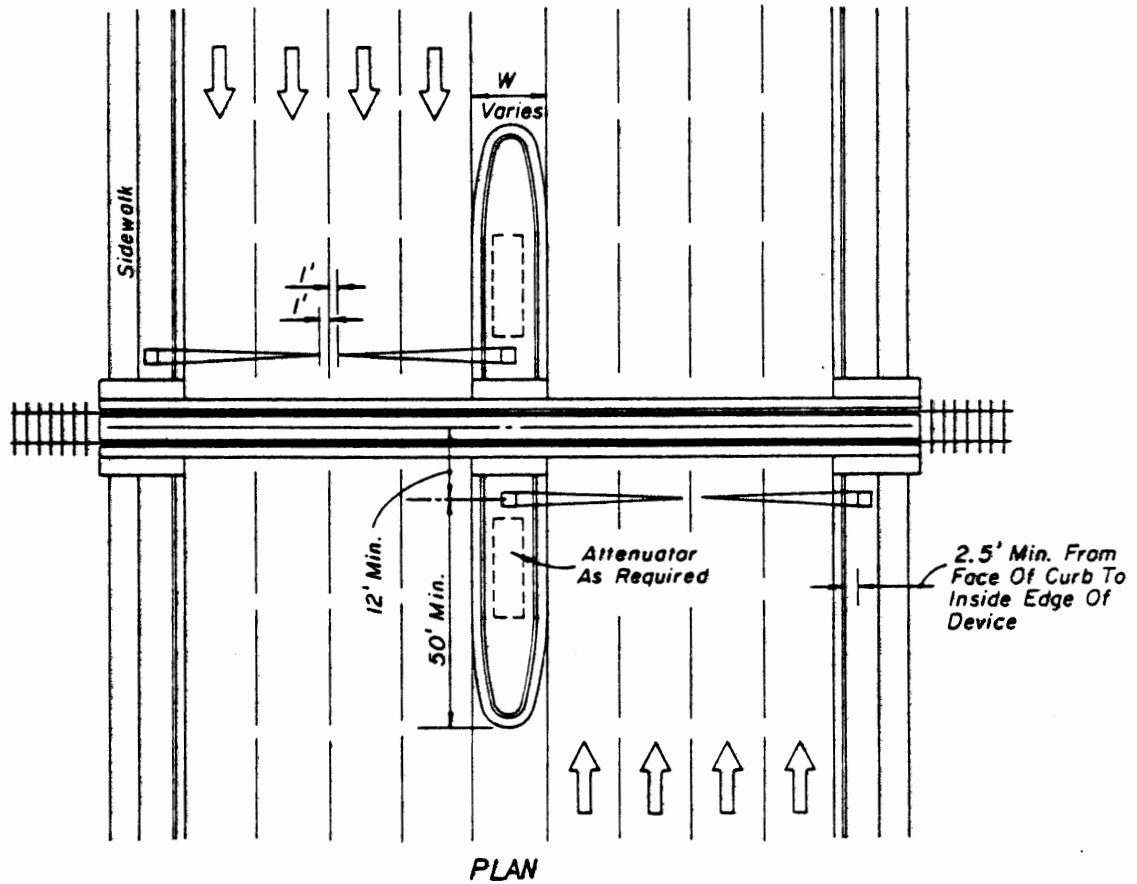

<b>MEDIAN WIDTH AND ATTENUATOR REQUIREMENTS</b>		
<i>Minimum Median Width ( W )</i>	<i>Curb Type</i>	<i>Attenuator</i>
10.67	A	<i>Required</i>
9.50	B	<i>Required</i>
9.83	D	<i>Not Required</i>
12.50	E & F	<i>Not Required</i>

*For additional information see Index No. 17882, the "Manual On Uniform Traffic Control Devices", Part VIII; the "Traffic Control Devices Handbook", Part VIII; and, AASHTO "A Policy On Geometric Design Of Streets and Highways", 1984.*



## SECTION VIII: PEDESTRIAN TRAFFIC

### A. Introduction

The layout and design of the highway network should include provisions for pedestrian traffic in urban areas. All pedestrian crossings and pathways within the highway right of way should be considered and designed as an integral part of any street or urban highway.

### B. Policy and Objectives

#### 1. New Facilities

The planning and design of new streets and urban highways shall include provisions for the safe orderly movement of pedestrian traffic. Provisions for pedestrian travel outside of the highway right of way should be considered.

The overall objective is to provide the safest practicable environment for pedestrian traffic.

#### 2. Existing Facilities

Each highway agency responsible for maintaining or operating streets and urban highways should establish and maintain a program of pedestrian safety for the urban highway network under its jurisdiction.

### C. Conflict Elimination and Reduction

The planning and design of new streets and urban highways shall include provisions for the elimination of vehicle-pedestrian conflicts wherever feasible. Conflict points would include pedestrian crossings, pathways parallel to the roadway, and other pedestrian activity adjacent to a street or highway.

The elimination of vehicle-pedestrian conflict points requires close coordination with the planning of pedestrian pathways and activity outside of the highway right of way. Care should be exercised to ensure that the elimination of a given conflict point does not merely transfer the problem to a different location. A reduction in the number of conflict points allows for economical and effective control and protection at the remaining points of conflict, thus providing an efficient method of pedestrian hazard reduction. Warrants and procedures for the elimination of vehicle-pedestrian conflicts are given in the subsequent material.

#### 1. General Warrants

The elimination of vehicle-pedestrian conflicts is accomplished by providing adequate horizontal, physical or vertical (primarily for crossings) separation between the roadway and the pedestrian pathways. The following locations may, however, be considered as warranting the

implementation of one or more of the methods for elimination of vehicle-pedestrian conflict.

a. Locations where the volume of pedestrian traffic is greater than the volume of vehicular traffic.

b. Areas with a large number of children or elderly pedestrians.

c. Areas adjacent to pedestrian generators such as schools, shopping centers, sports and amusement facilities, and parking facilities.

d. Sections of roadway that have any significant pedestrian traffic with one or more of the following:

1) A design speed (or posted speed limit) in excess of 40 MPH.

2) Minimal sight distance.

3) Significant changes in cross section or alignment.

4) Frequent vehicle maneuvers, decision points or distractions.

5) Limited right of way.

e. Crossings with one or more of the following conditions:

1) A high volume of pedestrians.

2) A significant number of children or elderly pedestrians.

3) The roadway operating at or near capacity.

## 2. Independent Systems

One ideal method for eliminating vehicle-pedestrian conflicts is to provide essentially independent systems for vehicular and pedestrian traffic. This requires adequate land use allocation and restriction, (see Section II LAND DEVELOPMENT) and the proper layout and design of pedestrian pathways and the highway network.

Where independent systems are provided intersections between the two modes (e.g., parking areas) are still required. Due to the small number of these intersections or conflict points, they can be economically developed for safe and efficient operation.

## 3. Horizontal Separation

The development of independent systems for pedestrian and vehicular traffic is the preferred method for providing adequate horizontal separation. If independent systems are not feasible or have not been provided, pedestrian pathways parallel to the roadway may be necessary.

a. General Criteria

Pedestrian pathways should be placed at least as far from the rural roadway as stipulated by the following criteria which are given in a sequence of desirability.

- 1) Outside of the highway right of way in a separately dedicated corridor.
- 2) At or near the right of way line.
- 3) Outside of the designed roadside clear zone.
- 4) Outside of the minimum required roadside clear zone (see Section III GEOMETRIC DESIGN).
- 5) As far from edge of driving lane as possible.

4. Physical Separation

Physical barriers may be used to assist in the separation of vehicular and pedestrian traffic.

a. Longitudinal barriers such as guardrails, rigid barriers and bridge railings are designed primarily to redirect errant vehicles away from roadside hazards. These barriers can also be used to provide valuable protection of pedestrian pathways from out-of-control vehicles.

Where adequate horizontal separation is not feasible, or where there is a significant hazard from out-of-control vehicles, longitudinal barriers may be utilized.

b. Fencing

The elimination of many potential vehicle-pedestrian conflicts may be accomplished by fencing to prevent pedestrian access to the roadway and to aid in channeling pedestrian traffic to the proper crossing points. Fencing shall not be considered as a substitute for longitudinal barriers but may be used in conjunction with these redirection devices.

Fencing may be utilized to prevent access to streets and highways at the locations described in C.1. General Warrants. Fencing at the right of way line and placement of pedestrian (and bicycle) pathways in separate corridors outside of this line is a necessary procedure on limited access facilities. This procedure should also be used on streets and highways experiencing high speeds, large volumes of vehicular and pedestrian (particularly children) traffic and at pedestrian generators.

## 5. Vertical Separations

The use of overpass and underpass structures provides an effective method for eliminating vehicle-pedestrian conflict. This procedure is generally necessary to develop fully independent systems since some intersections between the systems are generally unavoidable.

Vertical separation should be utilized to effect the crossing of large pedestrian volumes and high speed highways, particularly where the traffic volume on the roadway is at or near capacity. This method of conflict elimination is often justified at major pedestrian generators such as schools, shopping centers, sports and amusement facilities, commercial buildings, parks and playgrounds and parking facilities.

### a. Overpasses

The design of pedestrian bridges or overpasses should include provisions for additional vertical clearance since the consequences of being struck by a vehicle may be quite serious. Bridges should be covered or screened to reduce the likelihood of objects being dropped or thrown onto the roadway below.

### b. Underpasses

Pedestrian underpasses or tunnels perform the same function as overpasses. Their use is often convenient when the roadway is elevated somewhat above the surrounding terrain.

Underpasses may, however, be undesirable due to possible problems in lighting, cleaning, policing, and flooding. The area adjacent to overpasses and underpasses may be fenced to prevent unsafe crossings and to channel pedestrians to the vertical separation structure.

## D. Protection

The design of all pedestrian crossings and parallel pathways within the right of way shall be considered as an integral part of the overall design of a street or urban highway.

The development of protection at any remaining crossings or conflict points must be adequate to achieve a total pedestrian transportation mode that is reasonably safe.

### 1. Crossings

Curb cut ramps shall be constructed at cross walks at all intersections where curbs and sidewalks are constructed in order to give persons in wheelchairs safe access.

The design of pedestrian crossings should be based upon the following requirements.

a. Crossings should be placed at locations with ample sight distances.

b. At crossings, the roadway should be free from changes in alignment or cross section.

c. The entire length or crosswalk shall be visible to drivers at a sufficient distance to allow a stopping maneuver.

d. Stop bars shall be provided adjacent to all signalized crosswalks to inform drivers of the proper location to stop. The stop bar should be well separated from the crosswalk but should not be closer than 4 feet.

e. All crosswalks shall be easily identified and clearly delineated, in accordance with Manual of UTCD.

## 2. Controls

Signs, signals and markings should be utilized to provide the necessary information and direction for pedestrians. All directions and regulations should be clear, consistent and logical and should, as a minimum, conform to the requirements given in the Manual of UTCD. The use of audible as well as visual signals should be considered for pedestrian traffic control and regulation.

## 3. Sight Distance

The general requirements for sight distances for the driver are given in Section III GEOMETRIC DESIGN.

Stopping sight distances greater than the minimum should be provided at all pedestrian crossings. These sight distances should include a clear view of the pedestrian approach pathway for at least 15 feet from the outside travel lane. Where parallel pedestrian pathways are within the roadside recovery area, or where casual pedestrian crossings are likely, the normal required stopping sight distances should also include a clear view of the entire roadside recovery area.

Sight distances shall be based upon a driver's eye and object height as defined in AASHO design standards. Due to the small height and diameter of pedestrians (particularly children) they are generally easy to confuse with other background objects.

Parking shall be prohibited where it would interfere with the required sight distances. Particular care should be exercised to ensure that ample mutual sight distances are provided at all intersections and driveways.

#### 4. Lighting

Illumination of the roadway itself is not only important for the safety of vehicular traffic but also valuable for the protection of pedestrians. Vehicle headlamps often do not provide sufficient illumination to achieve the required stopping sight distance. Since this requirement is of vital importance at any potential pedestrian crossing point, illumination of the crossing should be considered. Lighting a street or highway is also valuable in improving the pedestrian's view of an oncoming vehicle. At intersections or other locations with vehicle turning maneuvers the vehicle headlights may not be readily visible to the pedestrian.

The general requirements for lighting on streets and highways are given in Section VI ROADWAY LIGHTING. Pathways adjacent to a street or highway should not be illuminated to a level more than twice that on the roadway itself.

In general, lighting should be considered as warranted when it is necessary, at night, to provide the mutual sight distance capabilities described in the preceding Chapter 3. Sight Distance. Locations with significant nighttime pedestrian traffic that should be considered for lighting of the roadway and the adjacent pedestrian pathways would include the following:

a. Any street or highway that meets the warranting criteria given in Section VI ROADWAY LIGHTING.

b. Streets and highways with a speed limit in excess of 40 mph that do not have adequate pedestrian conflict elimination.

c. Sections of highway with minimal separation of parallel pedestrian pathways.

d. Intersections, access and decision points, and areas adjacent to changes in alignment or cross section.

e. Areas adjacent to pedestrian generators.

f. Bus stops and other mass transit transfer locations.

g. Parking facilities.

h. Pedestrian crossings.

i. Any location where improvement of nighttime sight distance will reduce the hazard of vehicle-pedestrian conflicts.

## SECTION IX: Bicycle Facilities

Until recently the needs of bicyclists have not been built into the design consideration of Florida's roadways. In recognition of this need special care should be taken to review all proposed roadway improvements for obstacles, barriers and specific hazards to bicyclists.

Too often bikeways have been built where opportunities are available rather than where demand exists. At times bikeways drew bike riders out of the normal context of traffic (bi-directional bikeways), rendering them invisible from motorized traffic.

It is now recognized that to meet the transportation needs of the bicyclist it is necessary and appropriate to provide space and conditions suitable for shared road use throughout our transportation system. All new highways, except controlled access highways, should be designed and constructed under the assumption that they may be used by bicyclists. This requires special care in preparing the roadway surface to accommodate 1 1/4" tires (i.e., drainage grates, railroad crossings, lateral joints, placement of RPM's), enhanced maintenance of the right most portion of the roadway, and special lane widening and shoulder considerations.

It is now incorporated by reference as official standards the following document: FDOT Bicycle Facilities Planning and Design Manual, Revised August 1982 (and all subsequent revisions). This manual incorporates the October 1981 AASHTO "Guide For Development of New Bicycle Facilities", and provides Florida transportation officials with the most current and practical standards available.





## SECTION X: MAINTENANCE

### A. Introduction

In order to provide for the safe and efficient movement of all modes of traffic, it is essential to maintain all aspects of the road and right-of-way at the highest reasonable level of safety. Improvements consistent with upgrading of safety standards or changes in traffic are also required to maintain the facility in a quality condition. Since maintenance is a costly operation, every effort should be made to provide the maximum safety benefit from each maintenance operation. The fact that a major portion of the maintenance effort is necessary to merely preserve the economic investment in a facility should not be considered as justification for sacrificing the requirements for maintaining or improving the safety characteristics of a street or highway.

### B. Objectives

The major objectives of a maintenance program include the following:

1. Maintain all highway features and components in the best possible condition.
2. Improve sub-standard features, with the ultimate goal to at least meet minimum standards.
3. Provide for the minimum disruptions and hazards to traffic during maintenance operations.
4. Location and reporting of inadequate safety features.

### C. Policy

Each highway agency responsible for maintenance shall develop and maintain a program of highway maintenance for the entire highway network under its jurisdiction. This program shall include the following activities:

1. Identify needs.
2. Establish priorities.
3. Establish procedures.
4. Establish and maintain a regular program of maintenance for all aspects.

The program should be regularly evaluated and suitably modified to promote the maintenance of streets and highways in the best practicable condition.

#### D. Identification of Needs

The identification of maintenance needs is the first stage in the development of a successful maintenance program, and is required when any portion of the highway system is in a sub-standard condition. Action is also required to correct any situation which is hazardous or may become hazardous in the near future. This may be accomplished by both regular inspection of the highway network and proper analysis of accident records.

##### 1. Inspection

Periodic and systematic inspection of the entire highway network under each agency's jurisdiction is required to locate situations that require improvements, corrections or repairs. These inspections should be conducted by maintenance or traffic operations personnel, or other qualified personnel who are trained in the aspects of highway maintenance requirements. The cooperation of police and other agencies should be solicited to aid in maintaining the best possible surveillance of the system. The driving public should also be encouraged to provide assistance in identifying hazards or other unsafe conditions.

##### 2. Accident Records

A regular program of accident investigations, records keeping, and analysis should be established to provide information for recommended highway modification and corrective maintenance requirements. Cooperation between maintenance, traffic operations and police agencies is required, and activities of these agencies should be coordinated in accordance with the guidelines set forth in Highway Safety Program Standards Identification and Surveillance of Accident Locations. Inspection of the highway network and analysis of accident records should be utilized to provide feedback for modification of design and construction procedures.

#### E. Establishment of Priorities

The maintenance activities determined to be necessary by the identification program should be carried out on a priority basis. The establishment of priorities should be based to a large extent upon the objective of promoting highway safety. A high priority should be given to the improvement or correction of situations that may result in fatal or serious crashes. Preservation of highway investment and promotion of efficient traffic operations are important maintenance objectives. Every effort should be made to ensure the highest safety payoff from the maintenance dollar.

#### F. Establishment of Procedures

Standard procedures and methods for maintenance operations should be established for efficient, rapid and safe completion of the required work. All maintenance work shall be conducted in accordance with the standards set forth in Section XI WORK SITE SAFETY. Each maintenance agency should

develop its own Maintenance Manual or utilize the Maintenance Manuals of the Florida Department of Transportation. This manual should specify the methods, procedures, equipment, personnel qualifications and other aspects of the work necessary to ensure successful completion of maintenance operations. Procedures should be developed for emergency, routine and special operations.

#### 1. Emergency Maintenance

Emergency maintenance operations are those required to immediately restore the highway to a safe condition. Emergency maintenance work should be carried out by personnel who are specially trained and qualified. Work units, which should be available on a twenty-four hour basis, should be connected with the emergency response communications system. Emergency operations would include the following:

a. The removal of debris from crashes, cargo spillage or other causes. This activity should be conducted in accordance with the guidelines set forth in Highway Safety Program Standard 16. Debris Hazard Control and Cleanup.

b. Replacement of inoperative traffic control devices.

c. Repair or replacement of damaged highway safety components such as lighting, traffic control devices, redirection and energy absorbing devices.

d. Repair or correction of any situation that provides an immediate or unexpected hazard to the public.

e. Assistance in any activity during emergency response operations.

#### 2. Routine Maintenance

Routine maintenance operations are those that may be predicted and planned in advance. These operations, which may be preventive or corrective in nature, should be conducted on a regularly scheduled basis using standard procedures. Proper scheduling of these operations should be utilized to provide minimum disruptions and hazards to the driving public. Routine maintenance would include operations such as:

a. Cleaning and debris removal from the pavement, shoulders, and roadside clear zones.

b. Mowing and other vegetation control operations to provide a smooth recovery area and to maintain proper sight distance.

c. Cleaning and inspection of gutters, ditches and other drainage structures.

d. Structural inspection and preventive maintenance on bridges and other structures.

e. Cleaning, replacement and maintenance of roadway lighting fixtures.

f. Replacement and maintenance of traffic control devices.

g. Inspection and maintenance of redirection and energy absorbing devices. (See Section IV ROADSIDE DESIGN.)

h. Inspection and maintenance of emergency response communication systems and access facilities.

i. Inspection and maintenance of pavement and shoulders with particular emphasis on maintaining shoulders flush with the pavement. (See Section V PAVEMENT DESIGN, CONSTRUCTION AND MAINTENANCE.)

j. Inspection and maintenance of all highway components and safety features.

### 3. Special Maintenance

Special maintenance operations are defined as those projects that are neither urgent or routine in nature but are occasionally required to improve or maintain a street or highway in a quality condition. Since these projects can be planned in advance of the initiation of any work, procedures that provide for efficient, rapid and safe operations can be developed. To avoid continuing disruptions of traffic, the quality and durability of these improvements, corrections and repairs should be maintained at the highest practicable level. Special maintenance should include the upgrading of the highway safety features, as well as, the repair or replacement of damaged or deteriorated highway components. These operations should be designed to upgrade or maintain the street or highway in accordance with the standards presented in this Manual, and would include maintenance of the following features:

a. Pavement and Shoulders (See Section V PAVEMENT DESIGN, CONSTRUCTION AND MAINTENANCE.)

b. Roadside Clear Zones

Particular attention should be given to maintaining a smooth surface without discontinuities due to erosion or drainage problems. Large vegetation, non-flush drainage structures, poles or other unguarded hazards or structures should be removed or protected. (See Section IV ROADSIDE DESIGN.)

c. Redirection and Energy Absorbing Devices

Devices that are not properly performing their functions as described in Section IV ROADSIDE DESIGN should be quickly modified. A high priority should be given to adding required redirection and energy absorbing devices and to the correction or modification of inadequate devices.

d. Drainage Facilities

Drainage should be maintained to provide rapid removal of water from the pavement and shoulder to prevent overtopping of the roadway. Conditions promoting erosion or undermining of structures should be quickly corrected.

e. Roadway Lighting (See Section VI ROADWAY LIGHTING.)

f. Traffic Control Devices

These devices should be maintained in accordance with the standard set forth in the Manual of Uniform Traffic Control Devices.

g. Rail-Highway Grade Crossings (See Section VII RAIL-HIGHWAY GRADE CROSSINGS.)

h. Geometric Design Features

These features would include all aspects of geometric design described in Section III GEOMETRIC DESIGN. Particular attention should be given to the provision for maintenance of adequate sight distance at intersections and on curves. Vegetation or other objects that may obstruct vision shall be removed.

i. All Highway Safety Features and Components

Major improvement projects such as alinement improvements, changes in pavement, shoulder, median or recovery area widths, major installations of lighting, traffic control devices or redirection and energy absorbing devices should be considered as reconstruction projects. These projects should, where possible, meet the requirements for new construction as specified in this Manual.

G. Maintenance Program

The maintenance program should be carried out so as to correct the deficiencies determined by the identification of needs program. It is important to follow the established priorities in the scheduling of maintenance projects and to utilize the methods and procedures developed for the various maintenance operations. Improvements in methods, equipment and personnel training should be sought continuously to provide for rapid, efficient and safe maintenance operations. Careful and thorough inspection

of all maintenance projects should be conducted to ensure completion of the work in compliance with the standards prescribed by this Manual.

## SECTION XI: WORK SITE SAFETY

### A. Introduction

Construction, maintenance and utility operations produce serious highway safety problems. The changes in normal traffic flow and the unexpected conditions at many work sites provide hazardous situations and serious traffic conflicts. A comprehensive plan for work site safety is required to minimize the effects of these construction and maintenance operations.

### B. Objectives

The general objectives of a program of work site safety is to protect workmen, pedestrians and motorists during construction and maintenance operations. This general objective may be achieved by meeting the following specific objectives:

1. Provide adequate advance warning and information regarding upcoming work sites.
2. Provide the driver with clear directions and understanding of the situation he will be facing as he proceeds through or around the work site.
3. Reduce the consequences of an out-of-control vehicle.
4. Provide safe access and storage for equipment and material.
5. Promote speedy completion of projects (including thorough cleanup of the site).
6. Promote use of the appropriate traffic control and protection devices.
7. Provide safe passageways for pedestrians thru, in and/or around construction or maintenance work sites.

### C. Policy

Each highway agency with responsibility for construction, maintenance and operation of streets and highways shall develop and maintain a program of work site safety, as set forth in the Manual of Uniform Traffic Control Devices (MUTCD), as published by the Federal Department of Transportation (Federal Highway Administration). Additional guidance may be obtained from the Florida Department of Transportation's Roadway and Traffic Design Standards and the current Standard Specifications for Road and Bridge Construction.

#### D. Planning of Operations

The achievement of work site safety requires careful and complete planning prior to the initiation of any work project. The planning objective is to develop a complete operational plan which would include consideration of the following:

##### 1. Project Requirements

###### a. Type of Operation

Construction and maintenance projects may be classified as routine, emergency or special operations.

###### 1) Routine Operations

Routine operations would involve projects such as mowing, street cleaning and preventive maintenance operations that are conducted on a regularly scheduled basis.

###### 2) Emergency Operations

Emergency operations are those which require prompt efficient action to restore the roadway to a safe condition. These would include operations such as clearing storm or crash debris, repairing or replacing damaged highway safety components and restoring inoperative traffic control devices.

###### 3) Special Operations

Special operations are defined as those projects that are neither routine nor emergency in nature but are occasionally required to maintain or upgrade a street or highway. These would include any construction, maintenance, utility or other operation that would produce a hazard to workmen, pedestrians or motorists. Any activity that involves encroachment upon the highway right of way by workmen, equipment or material storage and transfer shall be subjected to the requirements for work site safety.

###### b. Nature of Work

The development of the operation plan for work site safety should include consideration of the following factors:

- 1) The time span required.
- 2) The requirements for continuous operation or occupation of the work site.



3) The capability of clearing the site during cessations of work activity.

4) The various construction methods, equipment, and procedures that may be utilized. Evaluation of alternate methods should be undertaken to determine the safest and most efficient procedures.

5) The necessity for storing equipment or material in the highway right of way.

6) Operations that may expose workmen to hazards from through traffic.

7) Hazards to out-of-control vehicles such as excavations or unguarded structures or equipment.

8) Site conditions that may be confusing or distracting to the driver or produce sight distance problems.

9) Particular problems associated with night safety.

10) Equipment inspection and preventive maintenance program.

### c. Nature of Work Site

The nature of the work site and the prevailing traffic conditions should, to a large degree, influence the procedures incorporated into the operation plan for work site safety. A determination of the normal vehicle speeds and traffic volumes is essential. The distribution of traffic with respect to time (hour, day, etc.) and direction is also important for establishing traffic control procedures.

## 2. Work Scheduling

Proper work scheduling and sequencing of operations will not only promote efficiency but also improve the safety aspects of construction and maintenance operations. Where feasible, routine operations and special projects should be conducted during periods of low traffic volume to reduce conflicts. Projects that may be carried out concurrently at the same site should be scheduled simultaneously to eliminate successive disruptions of traffic. Major projects that impede or restrict traffic flow should be coordinated and sequenced with similar projects in adjacent areas so as to produce a minimum of disruption to orderly traffic flow in the overall highway network. The scheduling of work at a given location should include consideration of traffic generation (including special events), as well as, traffic restrictions by work activities on the surrounding highway network.

## 3. Traffic Control and Protection

The plans for traffic control around or through work sites should be developed with safety receiving a high priority. The plans should

include protection at work sites when work is in progress and when operations have been halted (such as during the night). Provisions for the protection of work crews, traffic control personnel, pedestrians and motorists shall be included in the operation plans. In all cases the operation plan for traffic control and protection shall include provisions for the following:

- a. Advance Warning
- b. Clear View of Work Site
- c. Roadway Delineation
- d. Regulatory Information
- e. Hazard Warning
- f. Barriers
- g. Pedestrian Safety
- h. Access
- i. Location of Vehicles and Equipment
- j. Night Safety (See Section VI ROADWAY LIGHTING)
- k. Personnel Training
- l. Traffic Control and Protection Devices

4. Coordination with Other Agencies

To ensure safe and efficient construction and maintenance operations, the operation plan should be developed and executed in cooperation with all interested individuals and agencies including the following:

- a. Highway Agencies
- b. Police Agencies
- c. Emergency Agencies
- d. Contractors
- e. Utilities
- f. Building Departments
- g. Mass Transit Agencies

- h. Traffic Generators
- i. Local Residents
- j. Neighboring Jurisdictions

E. Work Site Operations

Construction and maintenance projects should follow the operation plan and should include:

1. Public Information

All reasonable effort should be made to inform the public of the location, duration and nature of impending construction or maintenance projects.

2. Contracts and Permits

For construction and reconstruction projects the general work site layout, the traffic control and protection procedures, occupational safety and health requirements and specific traffic control devices required should be incorporated in the contract plans and specifications.

Any construction work by utility companies that involves encroachment of the highway right of way by workmen, equipment, material storage and transfer or other hazardous conditions should be prohibited unless a permit by the appropriate highway agency is issued. Any maintenance by utility companies that involves encroachment of the highway right of way by workmen, equipment, material storage and transfer or other hazardous conditions shall be conducted in accordance with the requirements for work site safety and OSHA.

3. Inspection and Supervision

A regular program of inspection and supervision of all construction and maintenance projects shall be established and executed.

F. Evaluation of Program

The entire program for work site safety should be periodically evaluated and revised so as to provide the safest practicable environment for workmen, pedestrians and motorists during construction and maintenance operations.



## INDEX

- acceleration
  - III-5, 7, 41, 43, 45, 46, 47, 58, 59, 62, 68, 70, 71; VI-3, 8; VII-4
- access control
  - I-1, 2, 5, 6; II-1, 3, 4, 5, 7; III-39, 41, 42, 43, 44, 45, 58, 62, 67, 68; VII-5
- alinement
  - I-1, 2; II-1, 2; III-1, 5, 7, 9, 10, 11, 15, 16, 24, 30, 45, 61, 64, 67, 76; VI-2, 7; VII-3; VIII-2, 5, 6; X-5
- arterial
  - I-5, II-2, 3, 4, 5; III-4, 5, 10, 28, 32, 39, 40, 41, 62, 66, 68, 72
- at grade intersection
  - III-62
- auxiliary lane
  - III-28, 38, 43, 58, 59; VII-4
- average daily traffic (ADT)
  - 2
- average running speed
  - 4; III-3
- barriers
  - III-7, 27, 31, 32, 35, 39, 65, 66, 67, 71, 73, 76; IV-1, 3, 7, 8, 9; VI-5, 10; VIII-3; IX-1; XI-4
- bicycle facilities
  - III-25, 37, 72; IX-1
- bikeway
  - 4; IX-1
- border
  - IV-4
- braking
  - V-1
- breakaway supports
  - IV-7, 10
- bridges
  - III-37, 38, 39, 74, 76; IV-6, 7; VIII-4; X-3
- bus benches
  - III-74

- buses
  - III-6
- capacity
  - I-2, 5, 6; II-1, 2, 3, 5; III-8, 9, 25, 39, 40, 41, 44, 74, 75; VI-1, 6; VIII-2, 4
- channelization
  - III-40, 45, 67, 68
- channels
  - III-35
- classifications
  - I-5; III-2, 3, 25, 40
- clear zones
  - II-1; III-1, 31, 35, 37, 45, 58, 66, 71, 72, 73; IV-1, 2, 3, 4, 5, 6; VII-4; X-3,4
- clearances
  - III-5, 39, 65
- climbing lanes
  - III-16, 58
- collector
  - I-5; II-1, 2, 3, 4, 5; III-28, 36, 41, 43, 68, 72; VI-3, 8
- construction
  - I-1, 2, 3, 6, 7, 8; II-1, 2, 5, 7; III-1, 2, 7, 25, 26, 27, 35, 37, 38, 41, 43, 47, 62, 72, 74, 75, 76; IV-1, 7; V-1, 2, 3; VI-1, 2, 6, 7; VII-1, 6; X-2, 3, 4, 5; XI-1, 2, 3, 4, 5
- control devices
  - I-7; III-1, 3, 4, 39, 68, 73, 76; VI-4, 5, 9, 10; VII-1, 5; X-3, 5; XI-2, 5
- control of access
  - II-1, 2, 3, 6; III-32, 39, 40, 41, 43, 75
- coordination
  - I-6, 7, 8; II-1, 5; III-1, 17, 66; IV-8; VIII-1; XI-4
- crash cushion
  - IV-4, 9, 10; VII-5
- cross section
  - II-1; III-11, 25, 37, 38, 48, 62, 65, 67; IV-2; VII-4; VIII-2, 5, 6
- cross slope
  - III-11, 16, 25, 26, 27, 31, 32, 58, 67; VII-4

## INDEX

- crosswalks
  - III-46, 73; VIII-5
- crown
  - III-11, 67; VII-4
- culverts
  - III-38; IV-5
- cul-de-sac
  - III-38, 74
- curb cut ramps
  - III-73; VIII-5
- curbs
  - III-37, 67, 71, 73; IV-5, 6, 7, 8; V-2; VIII-5
- dead-end streets
  - III-38, 74
- deceleration
  - III-41, 43, 45, 58, 59, 62, 63, 67, 68, 69; IV-4, 7, 8, 9, 10; VI-3, 8; VII-4
- definitions
  - 2, 3, 4
- degree of curvature
  - III-9, 11
- design
  - I-1, 2, 3, 4, 5, 6, 7, 8; II-1, 2, 3, 4, 5, 6, 7; III-1, 2, 3, 4, 5, 6, 7, 9, 10, 11, 17, 20, 25, 26, 27, 31, 32, 35, 36, 37, 38, 39, 41, 43, 44, 45, 47, 48, 49, 55, 58, 59, 60, 62, 65, 66, 67, 68, 70, 71, 72, 73, 74, 75, 76; IV-1, 2, 3, 4, 5, 6, 7, 8, 9, 10; V-1, 2, 3; VI-1, 2, 4, 5, 6, 7, 9, 10; VII-1, 2, 3, 4, 5; VIII-1, 2, 3, 4, 5; IX-1; X-2, 3, 4, 5
- design hourly volume (DHV)
  - 3
- design speed
  - 3; III-3, 4, 5, 9, 10, 11, 20, 25, 27, 31, 36, 39, 45, 49, 58, 59, 62, 71; VI-7; VII-2, 3; VIII-2
- design vehicles
  - III-5, 6
- ditches
  - III-35; IV-5; X-3
- divided highways
  - III-17, 26, 30; IV-7; VII-4

INDEX

drainage

III-1, 10, 25, 26, 27, 31, 32, 35, 37, 67, 72, 73, 76; IV-2, 3, 4, 5;  
V-1, 2, 3, 4; VII-4; IX-1; X-3, 4, 5

driver

I-5, 6, 9; II-4, 5; III-3, 4, 5, 7, 8, 9, 10, 11, 16, 17, 27, 31, 32,  
40, 44, 45, 46, 47, 55, 58, 59, 66, 67, 68, 71; IV-1, 2, 3, V-1; VI-1,  
2, 4, 5, 6, 7, 9, 10; VII-2, 3, 5; VIII-5, XI-1, 3

driveways

II-4; III-10, 40, 44, 45, 46, 68; IV-5; VII-5; VIII-6

energy absorbing devices

IV-7, 9, 10; X-3, 5

exit lanes

III-59, 62

expressway

4; III-4, 66; VI-2, 7

fencing

VII-5; VIII-3, 4

freeways

4; II-5, III-10, 27, 28, 31, 32, 33, 39, 41, 58, 59, 71; VI-2, 3, 7, 8

friction

III-7, 10, 11, 47; V-1

frontage roads

3; II-5; III-37, 38, 75

grades

III-15, 16, 17, 19, 44, 50, 59, 60, 65; IV-2

grade separations

3; III-7, 37, 40; VII-1

guardrail

III-7, 35, 37, 39, 47, 66, 71, 73; IV-1, 3, 6, 7, 8, 9; VI-5, 10;  
VII-5; VIII-3

headlight

III-17, 27, 31, 32, 47; VI-2, 7; VIII-6

height

III-6, 7, 8, 37, 46; IV-5, 8; VI-1, 4, 6, 9; VII-2; VIII-5



## INDEX

### highway

3; I-1, 2, 3, 4, 5, 6, 7, 8, 9; II-1, 2, 3, 4, 5, 6; III-1, 2, 3, 5, 7, 8, 9, 10, 11, 12, 16, 17, 25, 26, 27, 29, 30, 31, 34, 37, 38, 39, 40, 41, 42, 43, 44, 46, 47, 48, 58, 59, 62, 64, 65, 66, 67, 68, 72, 73, 74, 75, 76; IV-1, 4, 6, 7; V-1, 2, 3, 4, 6, 7, 8, 9; VII-1, 2, 3, 4, 5, 6, 8; VIII-1, 2, 3, 4, 6; IX-1, 2, 3, 4, 5; XI-1, 2, 3, 4, 5

### horizontal alinement

III-7, 17, 25, 31, 65; IV-2; VII-3

### inlets

IV-4

### interchanges

III-25, 37, 44, 68, 70, 71; VI-3, 5, 8, 10

### intersection

3; II-1, 3, 4; III-5, 7, 8, 9, 16, 25, 31, 32, 36, 37, 39, 40, 41, 43, 44, 45, 46, 47, 48, 54, 62, 66, 67, 68, 71, 72, 73, 74, 75; IV-5, 6, 10; V-2; VII-1, 3, 5; VIII-2, 4, 5, 6; X-5

### islands

III-67

### land development

I-2, II-1, 2, 3, 4, 5, 6, 7; III-43, 72; VIII-2

### lanes

III-5, 8, 16, 25, 26, 27, 28, 31, 38, 39, 41, 43, 45, 46, 48, 58, 59, 60, 62, 64, 65, 66, 67, 71, 72; VI-3, 8; VII-4, 5

### lane widening

III-5, 11; IX-1

### lengths

III-16, 60, 62, 69, 70, 71

### level of service

I-2, 4, 5, 6; III-25

### lighting

II-4; III-1, 7, 40, 46, 47, 75; IV-6, 10; VI-1, 2, 3, 4, 5; VII-5; VIII-4, 6; X-3, 5; XI-4

### mailboxes

IV-7

### maintenance

I-1, 2, 3, 6, 7, 8; III-1, 25, 26, 43, 46, 74, 75; IV-1, 3; V-1, 3, 4; VI-1, 2, 4, 6, 7, 9; VII-1, 6; IX-1; X-1, 2, 3, 4, 5, 6; XI-1, 2, 3, 4, 5

## markings

III-16, 38, 44, 67, 68, 73; VII-5; VIII-5

## median

II-4; III-7, 17, 25, 26, 27, 31, 32, 33, 34, 38, 40, 48, 65, 67, 71, 72, 73, 75, 76; IV-1, 2, 4, 5, 6, 7, 9, 10; VII-4; X-5

## median barriers

III-7, 31, 32, 67, 76; IV-1, 7

## median openings

III-31, 40, 67

## merging

III-16, 38, 45, 58, 59, 68; IV-3

## new construction

3; III-2, 76; X-5

## parking

II-4, III-26, 37, 46; IV-1; VII-5; VIII-2, 4, 6

## passenger car

III-6, 58, 59, 62

## passing sight distance

III-8, 17, 22

## pavement

III-1, 2, 5, 10, 11, 16, 25, 26, 28, 29, 31, 32, 38, 46, 48, 55, 58, 59, 66, 67, 68, 72, 75, 76; IV-4; V-1, 2, 3, 4; VII-4, 5, 6; X-3, 4, 5

## pedestrian traffic

II-1; III-71, 72; VI-1, 3, 6, 8; VII-5; VIII-1, 2, 3, 4, 5, 6

## pedestrians

I-7; III-46, 71, 72, 73, 74; IV-2; VI-1, 6; VIII-1, 2, 3, 4, 5, 6; XI-1, 2, 3, 5

## planning

I-1, 2, 3, 6, 7, 8, 9; II-2, 5; III-25, 43; V-3; VIII-1; IX-1; XI-1

## protective devices

II-5; III-72; IV-2, 6, 7, 10; VII-1

## radii

III-5, 65, 66; VII-1

## rail - highway grade crossings

VII-1, 2, 3, 4, 5, 6, 7, 8, 9; X-5

## ramps

III-40, 66, 68, 73, 74; VI-3, 8; VIII-5

## INDEX

- reconstruction
  - 3; I-2, 7; II-7; III-1, 74, 75, 76; IV-1, 2, 3, 4, 5, 6; VII-1, 6; X-5, XI-5
- right-of-way
  - 3; II-1, 2, 5; III-1, 2, 7, 17, 37, 38, 72; X-1
- roadside
  - 3; II-1, 5, 7; III-1, 27, 31, 32, 35, 37, 39, 45, 66, 67, 71, 72, 73, 75, 76; IV-1, 2, 3, 4, 5, 6, 7, 8, 9, 10; VI-2, 5, 7, 10; VII-4, 5; VIII-3, 5; X-3, 4, 5
- roadside canals
  - IV-3
- roadway
  - II-2, 3, 5, 6; III-1, 2, 3, 4, 5, 7, 9, 10, 11, 17, 26, 27, 31, 32, 35, 37, 38, 39, 44, 45, 46, 47, 48, 58, 59, 62, 65, 66, 67, 68, 70, 71, 72, 73, 75, 76; IV-1, 2, 3, 4, 5, 6, 7, 9, 10; V-1, 2, 3; VI-1, 2, 3, 4, 5, 6, 7, 8, 9, 10; VII-2, 3, 5; VIII-1, 2, 3, 4, 5, 6; IX-1, X-3, 5; XI-2, 4
- shoulders
  - III-5, 16, 26, 30, 31, 35, 38, 39, 58, 66, 72, 73, 75; V-3, 4; VII-4; X-3, 4
- side slopes
  - III-35; IV-3, 5
- sidewalks
  - III-38, 39, 72, 73, 74; IV-7; VIII-3, 5
- sight distance
  - II-2, 4, 5, 6; III-1, 3, 5, 7, 8, 9, 17, 24, 25, 37, 40, 45, 46, 47, 48, 49, 50, 51, 52, 53, 75; IV-2; VI-1, 2, 5, 6, 7, 10; VII-2, 3, 5, 6, 8; VIII-2, 5, 6; X-3, 5; XI-3
- signs
  - III-4, 5, 17, 38, 44, 45, 46, 47, 71, 73, 75; IV-6, 10; VI-5, 10; VII-2, 4, 5; VIII-5
- skid resistance
  - I-1, 4, 5, 6; V-1, 2, 3; VII-6
- speed
  - I-1, 4, 5, 6; II-3; III-2, 3, 4, 5, 7, 8, 9, 10, 11, 16, 17, 20, 25, 27, 31, 35, 36, 37, 39, 41, 43, 45, 46, 47, 49, 58, 59, 60, 61, 61, 66, 71; IV-2, 5, 7, 10; V-2, 3; VI-3, 8; VII-2, 3; VIII-2, 4, 6; XI-1, 3
- speed change lanes
  - III-46, 60

## spirals

III-10

## stopping sight distance

III-7, 8, 17, 21, 23, 24, 45, 46, 47, 49, 65; VII-2; VIII-5, 6

## structures

III-7, 9, 35, 37, 38, 39, 40, 46, 71, 72, 76; IV-5, 6; V-2, 4; VI-5, 10; VII-3, 5; VIII-4; X-3, 4, 5; XI-3

## superelevation

III-9, 10, 11, 12, 13, 16, 25, 48, 65, 67; VII-3, 4

## tangent runout

III-11

## terminals

III-69, 70

## traffic

I-2, 3, 4, 5, 6, 7, 8; II-1, 2, 3, 4; III-1, 2, 3, 4, 5, 7, 8, 10, 16, 25, 26, 27, 31, 32, 35, 37, 38, 39, 40, 41, 42, 43, 44, 45, 46, 47, 48, 58, 59, 65, 67, 68, 71, 72, 73, 75, 76; IV-2, 3, 6; V-2; VI-1, 3, 4, 5, 6, 8, 9, 10; VI-1, 2, 4, 5, 6; VIII-1, 2, 3, 4, 5, 6; IX-1; X-1, 2, 3, 4, 5; XI-1, 2, 3, 4, 5

## traffic control

I-6, 7, 8; II-2; III-1, 3, 37, 39, 68, 73, 76; IV-6; VI-4, 5, 9, 10; VII-1, 5, 6; VIII-5; X-3, 5; XI-1, 2, 3, 4, 5

## traffic control devices

I-7; III-1, 3, 38, 39, 68, 73, 76; VI-4, 5, 9, 10; VII-1, 5; X-3, 5; XI-2, 5

## transit shelters

III-74

## transitions

III-10, 11, 66, 73; IV-9

## traveled way

3; II-4; III-32, 35, 71, 75; IV-1, 2

## trucks

III-6, 11, 16

## turning roadways

3; III-11, 46, 47, 62, 65, 66, 68

INDEX

turning lanes  
III-58

utilities  
I-3, 7; II-4; III-72, 73; IV-2, 6; XI-4

u-turns  
III-43

vehicles  
4; I-4, 9; III-2, 3, 5, 6, 16, 26, 27, 32, 35, 36, 39, 41, 45, 46, 47,  
48, 58, 59, 62, 65, 66, 67, 68, 71, 72, 73, 74, 75; IV-1, 2, 7; V-1, 3;  
VI-4, 9; VII-4, 5; VIII-3; XI-3, 4

vegetation  
III-7, 46, 75; IV-3, 4; X-3, 4, 5

vertical alinement  
III-1, 16, 17, 65; IV-2; VII-3

vertical clearances  
III-5, 39

vertical curves  
III-16, 44, 65; IV-2; VII-3

volume  
I-1, 4; III-1, 2, 5, 25, 26, 27, 28, 31, 35, 36, 37, 41, 43, 58, 59,  
72; IV-2; V-2; VI-3, 8; VII-4; VIII-2, 4; XI-3

warrants  
VI-2, 7; VIII-1, 4

widening  
II-5; III-5, 11, 75; IX-1

width  
III-2, 5, 6, 10, 11, 17, 25, 26, 27, 28, 29, 30, 31, 32, 33, 34, 35,  
36, 37, 38, 48, 58, 62, 65, 66, 67, 73; IV-2, 4, 7, 8; V-2; VI-4, 9;  
VII-3, 4; X-5

work site safety  
I-7; X-2; XI-1, 2, 3, 4, 5

