

2-LANE (2-WAY)
ARTERIAL/COLLECTOR
NEW CONSTRUCTION
RURAL
WITH BICYCLE LANES OR
PAVED SHOULDERS
DESIGN SPEED
GREATER THAN 45 MPH
WITH PROJECTED
20 YR. AADT OF 1500
OR GREATER

* B SURVEY AND/OR
Q CONSTRUCTION, AS APPLICABLE.

TRAFFIC DATA

CURRENT YEAR = 1998 AADT = 6800
ESTIMATED OPENING YEAR = 2000 AADT = 7600
ESTIMATED DESIGN YEAR = 2020 AADT = 12000
K = 6% D = 55% T = 2% (24 HOUR)
DESIGN HOUR T = 1%
DESIGN SPEED = 55 MPH

TRAFFIC DATA IS REQUIRED TO BE NOTED FOR
CURRENT YEAR, OPENING YEAR AND DESIGN YEAR.
POSTED SPEED (MPH) IS OPTIONAL.

FOR STANDARD TYPICAL SECTION NOTES
REFER TO EXHIBIT 6-1, THIS CHAPTER.

**TYPICAL SECTION
SR 10 (U.S. 90-A)
STA. 10+00.00 TO STA. 267+34.89**

NEW CONSTRUCTION

OPTIONAL BASE GROUP 8 WITH
TYPE SP STRUCTURAL COURSE (TRAFFIC C) (2")
AND FRICTION COURSE FC-12.5 (TRAFFIC C) (1 1/2") PG 76-22

SHOULDER PAVEMENT

OPTIONAL BASE GROUP 1 WITH
FRICTION COURSE FC-12.5 (TRAFFIC C) (1 1/2") PG 76-22

NOTE:
HEIGHT OF FILL IS THE VERTICAL DISTANCE
FROM THE EDGE OF THE OUTSIDE TRAVEL LANE
TO TOE OF FRONT SLOPE.

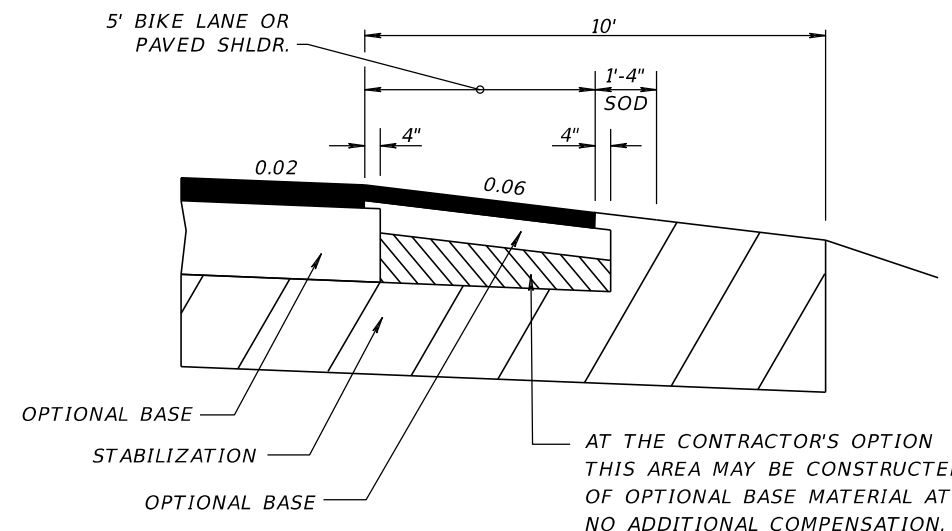

SHOULDER PAVEMENT DETAIL

EXHIBIT TYP-1
Date: 1/1/17

REVISIONS				STATE OF FLORIDA DEPARTMENT OF TRANSPORTATION			SHEET NO.
DATE	DESCRIPTION	DATE	DESCRIPTION	ROAD NO.	COUNTY	FINANCIAL PROJECT ID	
				22	BAY	123456-1-52-01	

TYPICAL SECTION

THE OFFICIAL RECORD OF THIS SHEET IS THE ELECTRONIC FILE DIGITALLY SIGNED AND SEALED UNDER RULE 61G15-23.004, F.A.C.

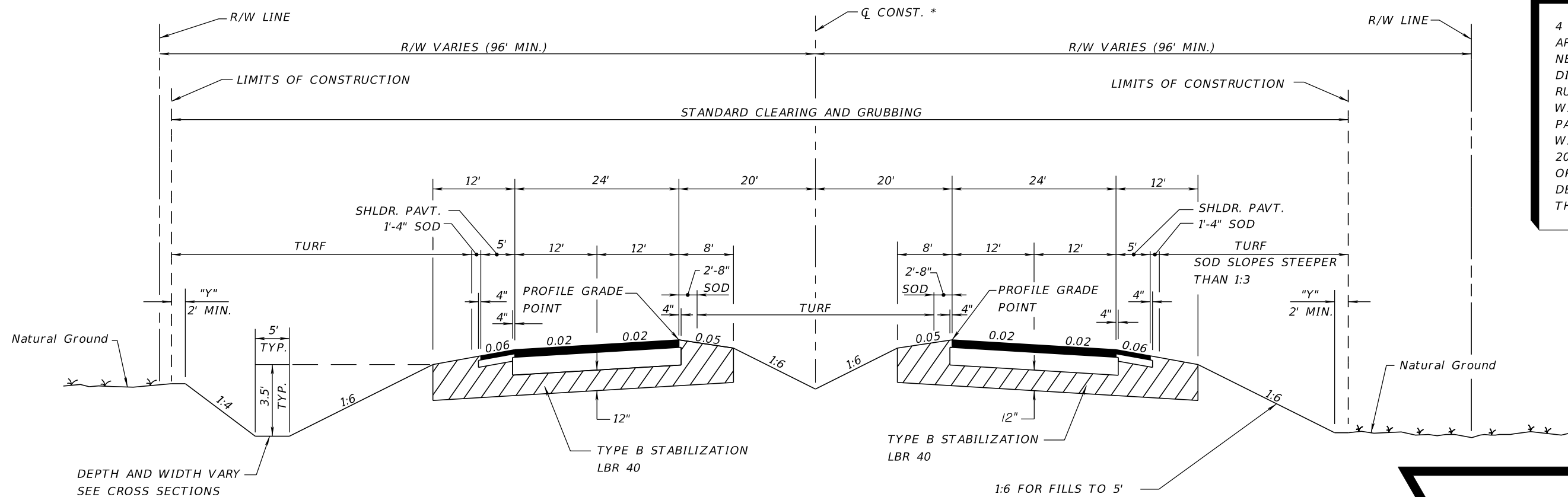

4 LANE
ARTERIAL/COLLECTOR
NEW CONSTRUCTION
DIVIDED
RURAL
WITH BICYCLE LANES OR
PAVED SHOULDERS
WITH PROJECTED
20 YR. AADT OF 1500
OR GREATER
DESIGN SPEED GREATER
THAN 50 MPH

**TYPICAL SECTION
SR 500
STA. 63+65.42 TO STA. 328+65.14**

TRAFFIC DATA

CURRENT YEAR = 1998 AADT = 22300
ESTIMATED OPENING YEAR = 2000 AADT = 23300
ESTIMATED DESIGN YEAR = 2020 AADT = 51500
K = 9% D = 56% T = 10% (24 HOUR)
DESIGN HOUR T = 5%
DESIGN SPEED = 70 MPH

NEW CONSTRUCTION
OPTIONAL BASE GROUP 9 WITH
TYPE SP STRUCTURAL COURSE (TRAFFIC D) (2")
TYPE SP STRUCTURAL COURSE (TRAFFIC D) (1 1/2") (PG 76-22)
AND FRICTION COURSE FC-5 (3/4") (PG 76-22)

SHOULDER PAVEMENT
OPTIONAL BASE GROUP 1 WITH
TYPE SP STRUCTURAL COURSE (TRAFFIC D) (1 1/2") (PG 76-22)
AND FRICTION COURSE FC-5 (3/4") (PG 76-22)

1:6 FOR FILLS TO 5'
1:6 TO EDGE OF CLEAR ZONE & 1:4 FOR FILLS 5' TO 10'
1:6 TO EDGE OF CLEAR ZONE & 1:3 FOR FILLS 10' TO 20'
1:2 (WITH GUARDRAIL) FILLS OVER 20'

NOTE:
HEIGHT OF FILL IS THE VERTICAL DISTANCE
FROM THE EDGE OF THE OUTSIDE TRAVEL LANE
TO TOE OF FRONT SLOPE.

* \bar{Q} SURVEY AND/OR
 \bar{Q} CONSTRUCTION, AS APPLICABLE.

"Y" THE AREA DISTURBED BY
CONSTRUCTION VARIES.

TRAFFIC DATA IS REQUIRED TO BE
NOTED FOR CURRENT YEAR,
OPENING YEAR, AND DESIGN YEAR.
POSTED SPEED (MPH) IS OPTIONAL.

FOR STANDARD TYPICAL SECTION NOTES
REFER TO EXHIBIT 6-1, THIS CHAPTER.

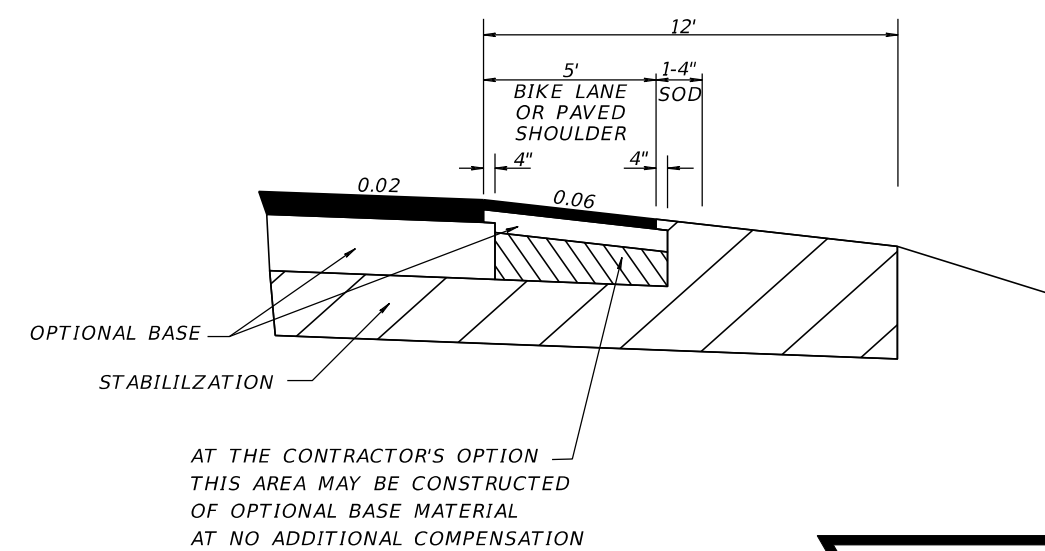

AT THE CONTRACTOR'S OPTION
THIS AREA MAY BE CONSTRUCTED
OF OPTIONAL BASE MATERIAL
AT NO ADDITIONAL COMPENSATION

SHOULDER PAVEMENT DETAIL

EXHIBIT TYP-2
Date: 1/1/17

REVISIONS				STATE OF FLORIDA DEPARTMENT OF TRANSPORTATION			SHEET NO.
DATE	DESCRIPTION	DATE	DESCRIPTION	ROAD NO.	COUNTY	FINANCIAL PROJECT ID	
				22	BAY	123456-1-52-01	TYPICAL SECTION

THE OFFICIAL RECORD OF THIS SHEET IS THE ELECTRONIC FILE DIGITALLY SIGNED AND SEALED UNDER RULE 61G15-23.004, F.A.C.

5-LANE SECTIONS ARE TO INCLUDE SECTIONS OF RAISED OR RESTRICTIVE MEDIAN. SEE PPM TABLE 2.2.1.

*** \bar{Q} SURVEY AND/OR \bar{Q} CONSTRUCTION, AS APPLICABLE.

5-LANE ARTERIAL/COLLECTOR NEW CONSTRUCTION UNDIVIDED URBAN WITH BICYCLE LANES MINIMUM RIGHT OF WAY DESIGN SPEED 40 MPH OR LESS WITH PROJECTED 20 YR. AADT OF 1500 OR GREATER

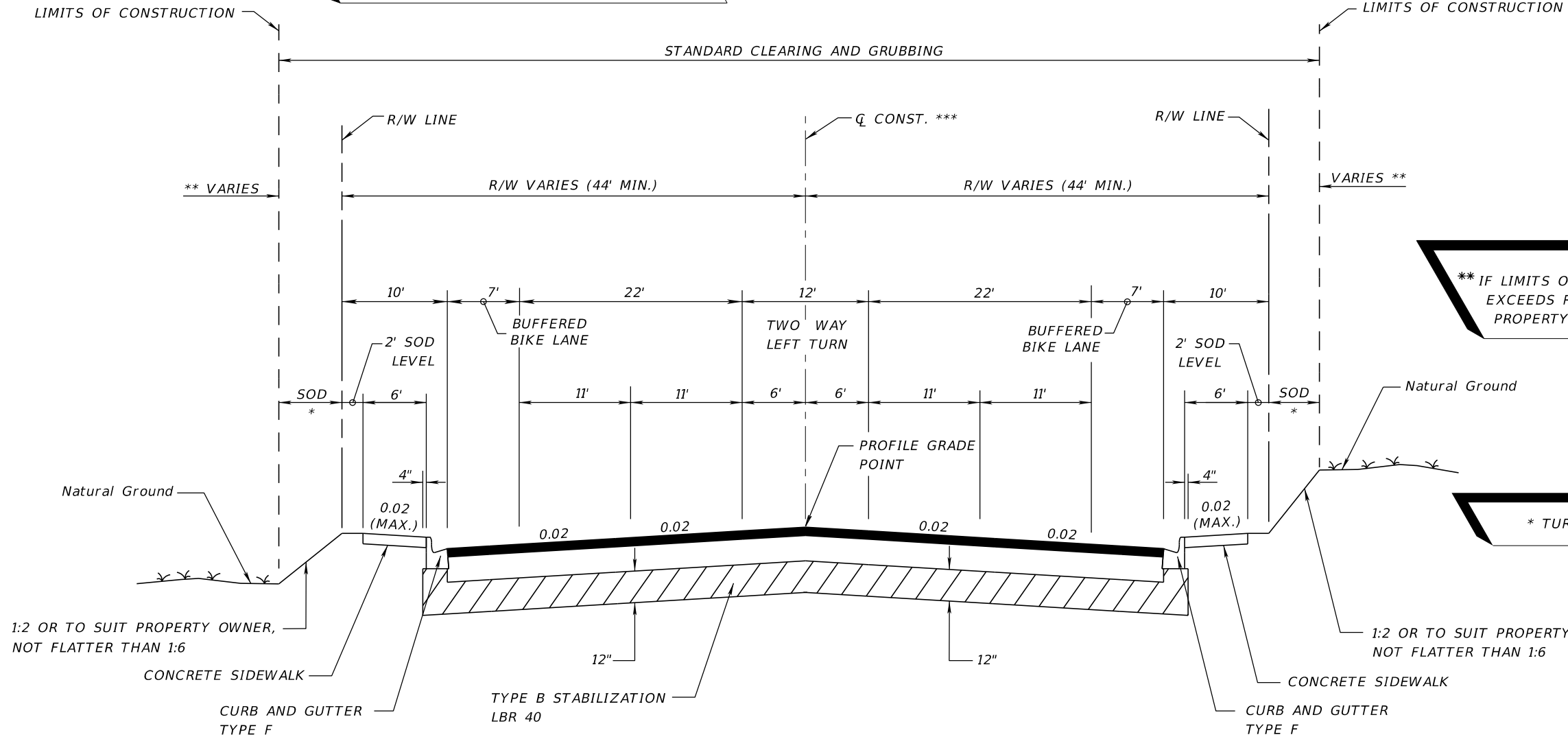

** IF LIMITS OF CONSTRUCTION EXCEEDS RIGHT OF WAY, A PROPERTY AGREEMENT IS REQUIRED.

* TURF OR SOD

**TYPICAL SECTION
SR 00 (DUVAL STREET)
STA. 252+12.00 TO STA. 323+19.42**

NEW CONSTRUCTION

OPTIONAL BASE GROUP 8 WITH
TYPE SP STRUCTURAL COURSE (TRAFFIC B) (1 1/2")
AND FRICTION COURSE FC-12.5 (TRAFFIC B) (1 1/2") (PG 76-22)

TRAFFIC DATA

CURRENT YEAR = 1998 AADT = 9900
ESTIMATED OPENING YEAR = 2000 AADT = 10600
ESTIMATED DESIGN YEAR = 2020 AADT = 14000
K = 6% D = 55% T = 2% (24 HOUR)
DESIGN HOUR T = 1%
DESIGN SPEED = 40 MPH

TRAFFIC DATA IS REQUIRED TO BE NOTED FOR CURRENT YEAR, OPENING YEAR AND DESIGN YEAR. POSTED SPEED (MPH) IS OPTIONAL.

FOR STANDARD TYPICAL SECTION NOTES REFER TO EXHIBIT 6-1, THIS CHAPTER.

EXHIBIT TYP-3
Date: 1/1/16

REVISIONS				STATE OF FLORIDA DEPARTMENT OF TRANSPORTATION			SHEET NO.
DATE	DESCRIPTION	DATE	DESCRIPTION	ROAD NO.	COUNTY	FINANCIAL PROJECT ID	
				22	BAY	123456-1-52-01	

TYPICAL SECTION

5-LANE SECTIONS ARE TO INCLUDE SECTIONS OF RAISED OR RESTRICTIVE MEDIAN. SEE PPM TABLE 2.2.1.

*** \bar{Q} SURVEY AND/OR \bar{Q} CONSTRUCTION, AS APPLICABLE.

5-LANE ARTERIAL/COLLECTOR NEW CONSTRUCTION UNDIVIDED URBAN WITH BICYCLE LANES DESIGN SPEED 40 MPH OR LESS WITH PROJECTED 20 YR. AADT OF 1500 OR GREATER

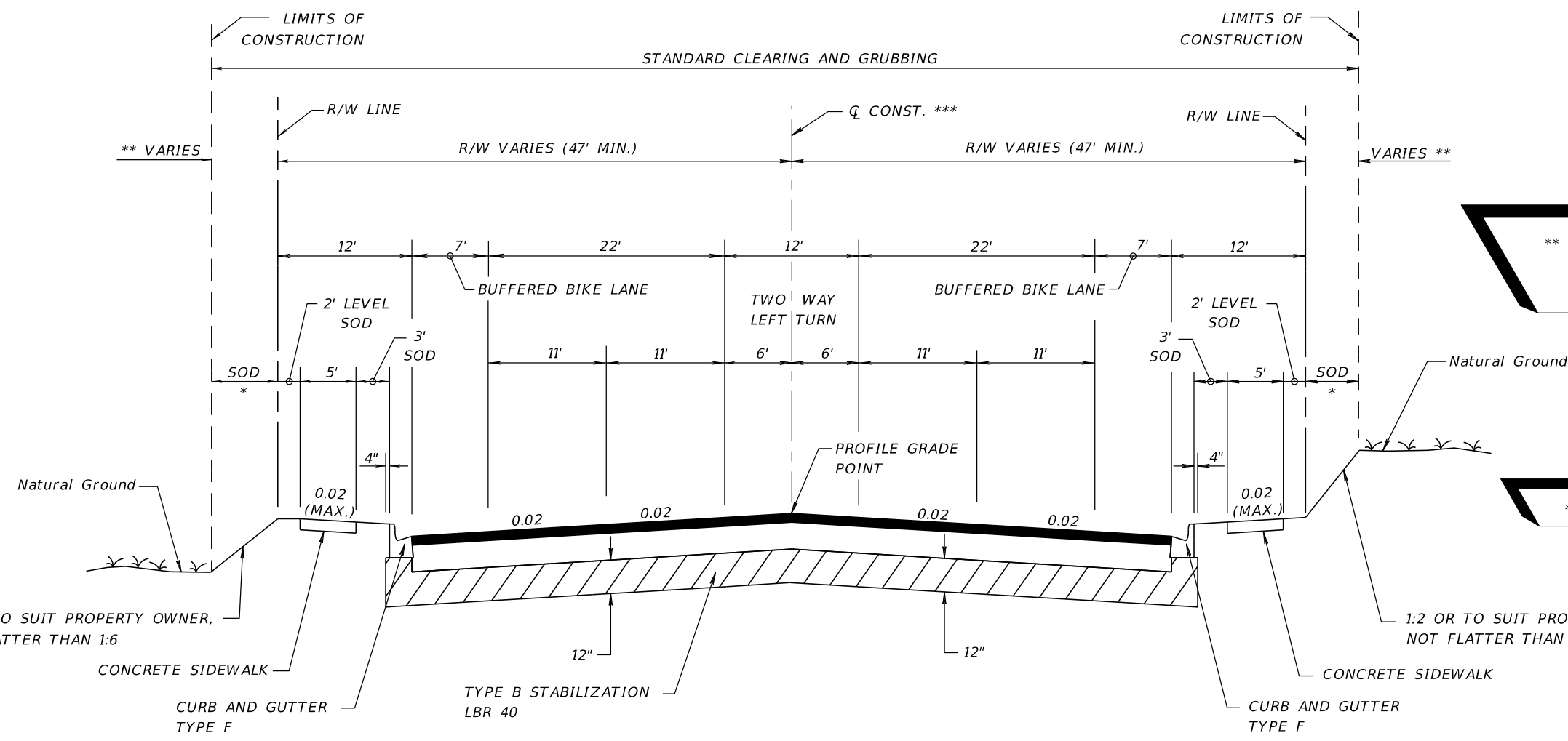

** IF LIMITS OF CONSTRUCTION EXCEEDS RIGHT OF WAY, A PROPERTY AGREEMENT IS REQUIRED.

* TURF OR SOD

TRAFFIC DATA

CURRENT YEAR = 1998 AADT = 20819
 ESTIMATED OPENING YEAR = 2003 AADT = 24100
 ESTIMATED DESIGN YEAR = 2023 AADT = 24900
 K = 9% D = 60% T = 2% (24 HOUR)
 DESIGN HOUR T = 1%
 DESIGN SPEED = 40 MPH

**TYPICAL SECTION
 SR 00 (MATTHEWS STREET)
 STA. 202+42.00 TO STA. 263+29.68**

NEW CONSTRUCTION
 OPTIONAL BASE GROUP 8 WITH
 TYPE SP STRUCTURAL COURSE (TRAFFIC B) (1 1/2")
 AND FRICTION COURSE FC-12.5 (TRAFFIC B) (1 1/2") (PG 76-22)

FOR STANDARD TYPICAL SECTION NOTES REFER TO EXHIBIT 6-1, THIS CHAPTER.

TRAFFIC DATA IS REQUIRED TO BE NOTED FOR CURRENT YEAR, OPENING YEAR AND DESIGN YEAR. POSTED SPEED (MPH) IS OPTIONAL.

EXHIBIT TYP-4
 Date: 1/1/15

REVISIONS				STATE OF FLORIDA DEPARTMENT OF TRANSPORTATION	SHEET NO.
DATE	DESCRIPTION	DATE	DESCRIPTION		
				22 BAY 123456-1-52-01	

THE OFFICIAL RECORD OF THIS SHEET IS THE ELECTRONIC FILE DIGITALLY SIGNED AND SEALED UNDER RULE 61G15-23.004, F.A.C.

*** \bar{R} SURVEY AND/OR
 \bar{Q} CONSTRUCTION, AS APPLICABLE.

4-LANE
 ARTERIAL
 NEW CONSTRUCTION
 DIVIDED
 URBAN
 WITH BIKE LANES
 DESIGN SPEED 45 MPH OR LESS

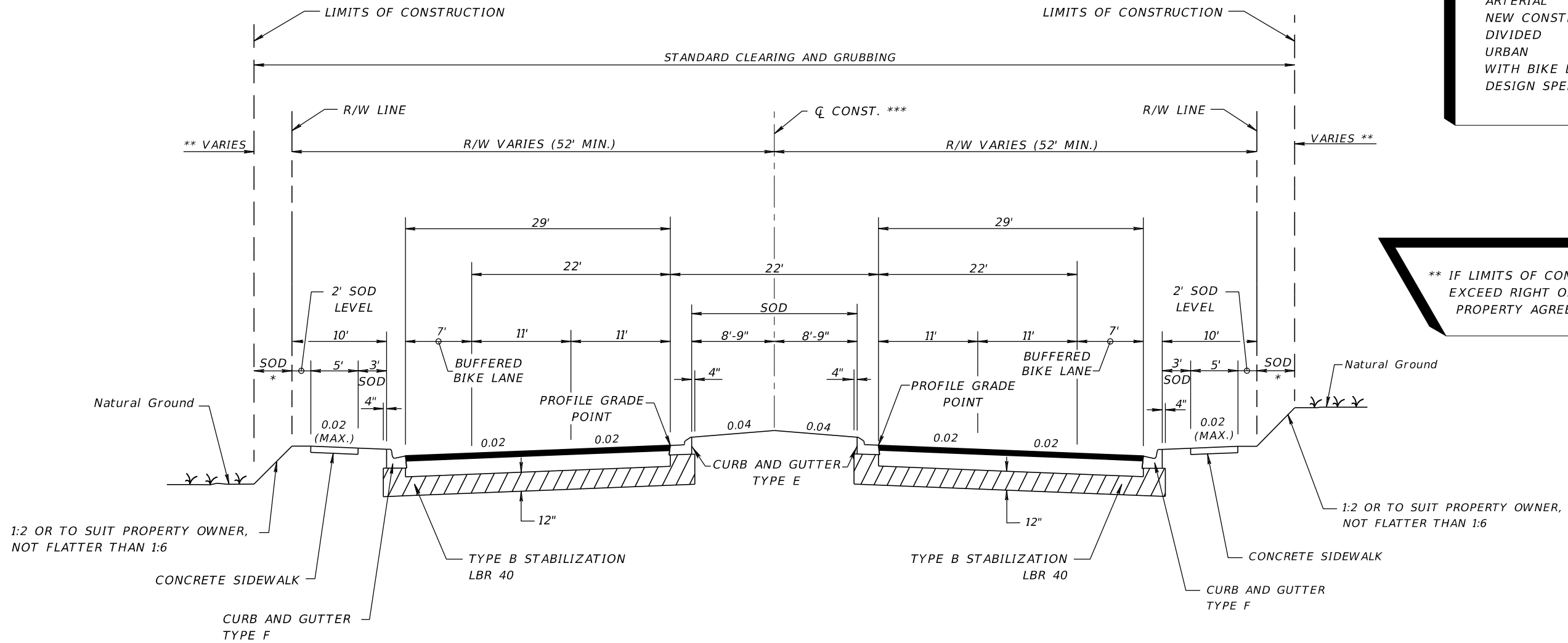

** IF LIMITS OF CONSTRUCTION
 EXCEED RIGHT OF WAY, A
 PROPERTY AGREEMENT IS REQUIRED.

**TYPICAL SECTION
 SR 00 (WILSON STREET)
 STA. 98+40.00 TO STA. 202+33.00**

NEW CONSTRUCTION
 OPTIONAL BASE GROUP 9 WITH
 TYPE SP STRUCTURAL COURSE (TRAFFIC B) (1 1/2")
 AND FRICTION COURSE FC-12.5 (TRAFFIC B) (1 1/2") (PG 76-22)

TRAFFIC DATA

CURRENT YEAR = 1998 AADT = 22800
 ESTIMATED OPENING YEAR = 2000 AADT = 25800
 ESTIMATED DESIGN YEAR = 2020 AADT = 30600
 K = 6% D = 55% T = 2% (24 HOUR)
 DESIGN HOUR T = 1%
 DESIGN SPEED = 45 MPH

* TURF OR SOD

FOR STANDARD TYPICAL SECTION NOTES
 REFER TO EXHIBIT 6-1, THIS CHAPTER.

TRAFFIC DATA IS REQUIRED TO BE
 NOTED FOR CURRENT YEAR, OPENING
 YEAR AND DESIGN YEAR.
 POSTED SPEED (MPH) IS OPTIONAL.

EXHIBIT TYP-5
 Date: 1/1/15

REVISIONS				STATE OF FLORIDA DEPARTMENT OF TRANSPORTATION			SHEET NO.
DATE	DESCRIPTION	DATE	DESCRIPTION	ROAD NO.	COUNTY	FINANCIAL PROJECT ID	
				22	BAY	123456-1-42-01	TYPICAL SECTION

THE OFFICIAL RECORD OF THIS SHEET IS THE ELECTRONIC FILE DIGITALLY SIGNED AND SEALED UNDER RULE 61G15-23.004, F.A.C.

*** \square SURVEY AND/OR
 \square CONSTRUCTION, AS APPLICABLE.

** IF LIMITS OF CONSTRUCTION
 EXCEED RIGHT OF WAY, A
 PROPERTY AGREEMENT IS REQUIRED.

6-LANE
 ARTERIAL
 NEW CONSTRUCTION
 DIVIDED
 URBAN
 WITH BIKE LANES
 DESIGN SPEED 45 MPH OR LESS

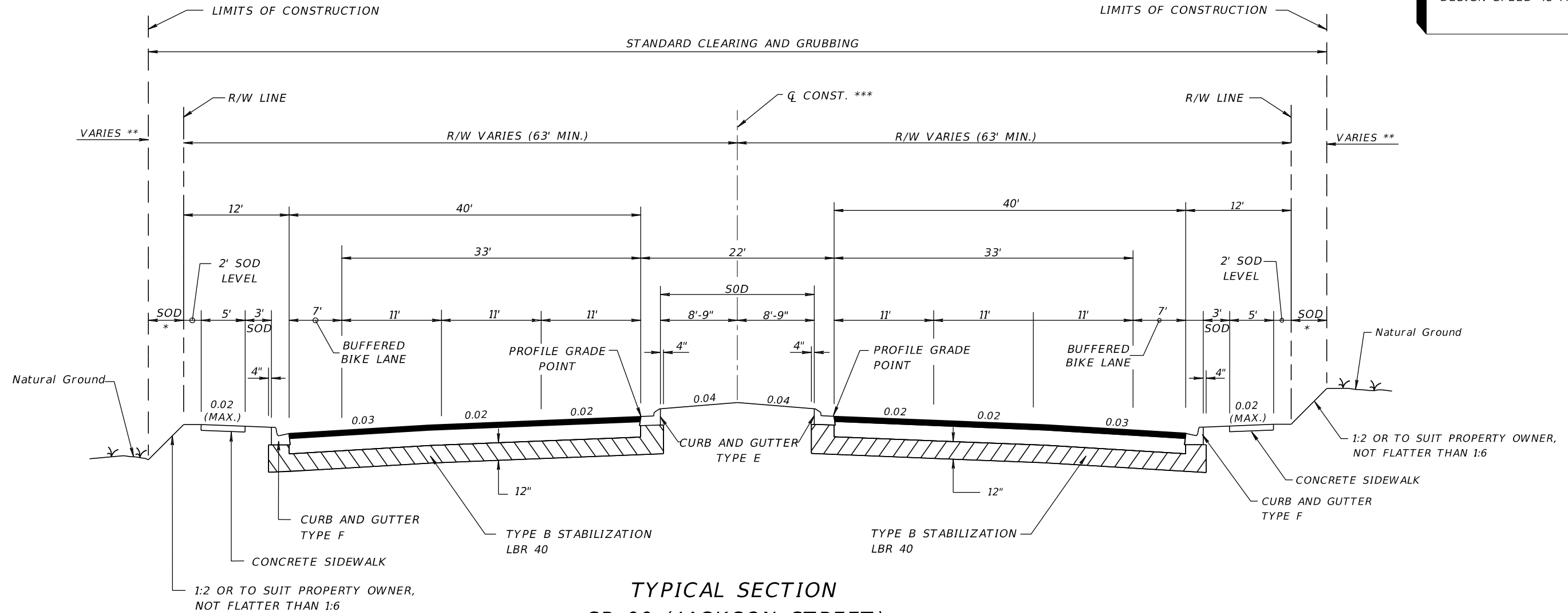

**TYPICAL SECTION
 SR 00 (JACKSON STREET)
 STA. 101+21.00 TO STA. 221+44.00**

TRAFFIC DATA

CURRENT YEAR = 1998 AADT = 22800
 ESTIMATED OPENING YEAR = 2000 AADT = 25800
 ESTIMATED DESIGN YEAR = 2020 AADT = 30600
 K = 6% D = 55% T = 2% (24 HOUR)
 DESIGN HOUR T = 1%
 DESIGN SPEED = 45 MPH

TRAFFIC DATA IS REQUIRED TO BE
 NOTED FOR CURRENT YEAR, OPENING
 YEAR AND DESIGN YEAR.

NEW CONSTRUCTION
 OPTIONAL BASE GROUP 9 WITH
 TYPE SP STRUCTURAL COURSE (TRAFFIC C) (2")
 AND FRICTION COURSE FC-12.5 (TRAFFIC C) (1 1/2") (PG 76-22)

* TURF OR SOD

FOR STANDARD TYPICAL SECTION NOTES
 REFER TO EXHIBIT 6-1, THIS CHAPTER.

EXHIBIT TYP-6
 Date: 1/1/15

REVISIONS				STATE OF FLORIDA DEPARTMENT OF TRANSPORTATION			SHEET NO.
DATE	DESCRIPTION	DATE	DESCRIPTION	ROAD NO.	COUNTY	FINANCIAL PROJECT ID	
				22	BAY	123456-5-20-1	

TYPICAL SECTION

*** \bar{Q} SURVEY AND/OR
 \bar{Q} CONSTRUCTION, AS APPLICABLE.

** IF LIMITS OF CONSTRUCTION
 EXCEED RIGHT OF WAY, A
 PROPERTY AGREEMENT IS REQUIRED.

6-LANE
 ARTERIAL
 NEW CONSTRUCTION
 DIVIDED
 URBAN
 WITH BIKE LANES
 DESIGN SPEED 45 MPH OR LESS

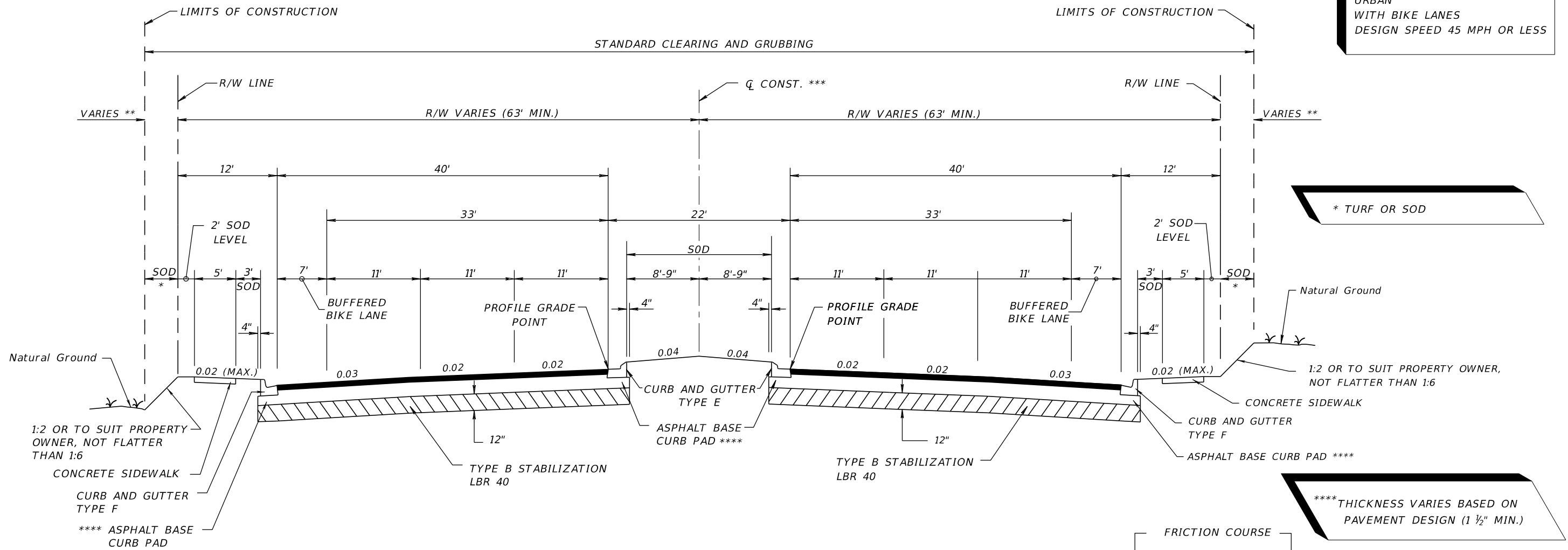

* TURF OR SOD

**** THICKNESS VARIES BASED ON
 PAVEMENT DESIGN (1 1/2" MIN.)

**TYPICAL SECTION
 SR 00 (JACKSON STREET)
 STA. 101+21.00 TO STA. 221+44.00**

NEW CONSTRUCTION
 OPTIONAL BASE GROUP 9 (TYPE B-12.5 ONLY), WITH
 TYPE SP STRUCTURAL COURSE (TRAFFIC C) (3")
 AND FRICTION COURSE FC-12.5 (TRAFFIC C) (1 1/2") (PG 76-22)

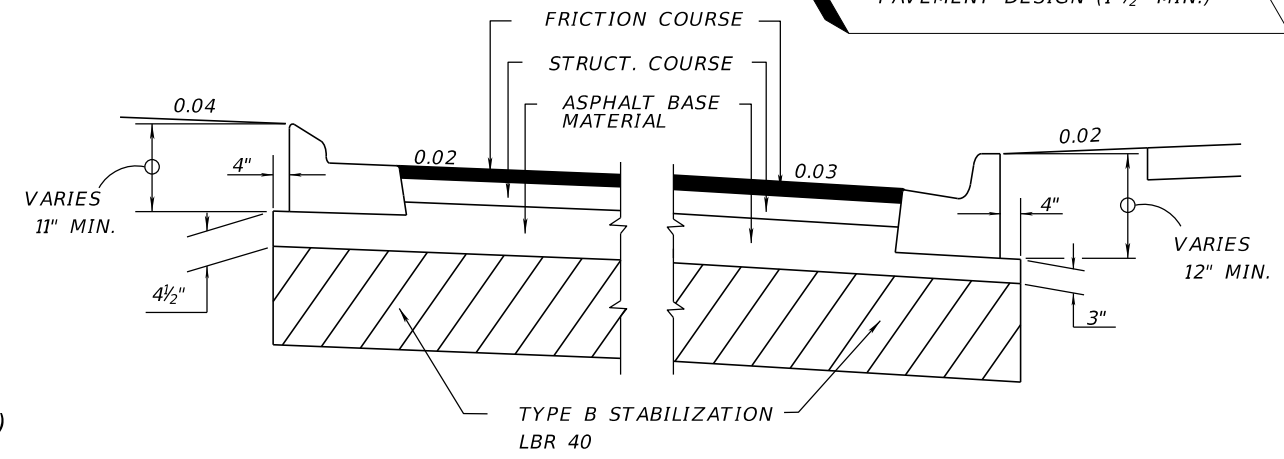

DETAIL OF ASPHALT BASE CURB PAD

TRAFFIC DATA

CURRENT YEAR = 1998 AADT = 22800
 ESTIMATED OPENING YEAR = 2000 AADT = 25800
 ESTIMATED DESIGN YEAR = 2020 AADT = 30600
 K = 6% D = 55% T = 2% (24 HOUR)
 DESIGN HOUR T = 1%
 DESIGN SPEED = 45 MPH

FOR STANDARD TYPICAL SECTION NOTES
 REFER TO EXHIBIT 6-1, THIS CHAPTER

TRAFFIC DATA IS REQUIRED TO BE
 NOTED FOR CURRENT YEAR, OPENING
 YEAR AND DESIGN YEAR.

EXHIBIT TYP-6A
 Date: 1/1/13

REVISIONS				STATE OF FLORIDA DEPARTMENT OF TRANSPORTATION			SHEET NO.
DATE	DESCRIPTION	DATE	DESCRIPTION	ROAD NO.	COUNTY	FINANCIAL PROJECT ID	
				22	BAY	123456-1-52-01	

TYPICAL SECTION

THE OFFICIAL RECORD OF THIS SHEET IS THE ELECTRONIC FILE DIGITALLY SIGNED AND SEALED UNDER RULE 61G15-23.004, F.A.C.

* \bar{E} SURVEY AND/OR
 \bar{C} CONSTRUCTION, AS APPLICABLE.

FOR STANDARD TYPICAL SECTION NOTES
REFER TO EXHIBIT 6-1, THIS CHAPTER.

NOTES:
1. CROSS SLOPE CORRECTION IS REQUIRED IF
EXISTING CONDITIONS ARE NOT WITHIN THE RANGES OF
PPM VOLUME 1, CHAPTER 25 CRITERIA.
2. WHEN CROSS SLOPE CORRECTION IS NECESSARY,
SPECIAL MILLING, OVERBUILD, AND LAYERING DETAILS
MUST BE PROVIDED TO SUPPLEMENT TYPICAL SECTION.
THE NEED FOR AND LOCATION OF PROFILE GRADE
POINTS WILL DEPEND ON SITE SPECIFIC CONDITIONS.

EXISTING
2-LANE (2-WAY)
ARTERIAL/COLLECTOR
MILLING AND RESURFACING
UNDIVIDED
RURAL
(WITH EXISTING BIKE LANES
OR PAVED SHOULDERS)
WITH PROJECTED 20 YR.
AADT OF 1500 OR GREATER

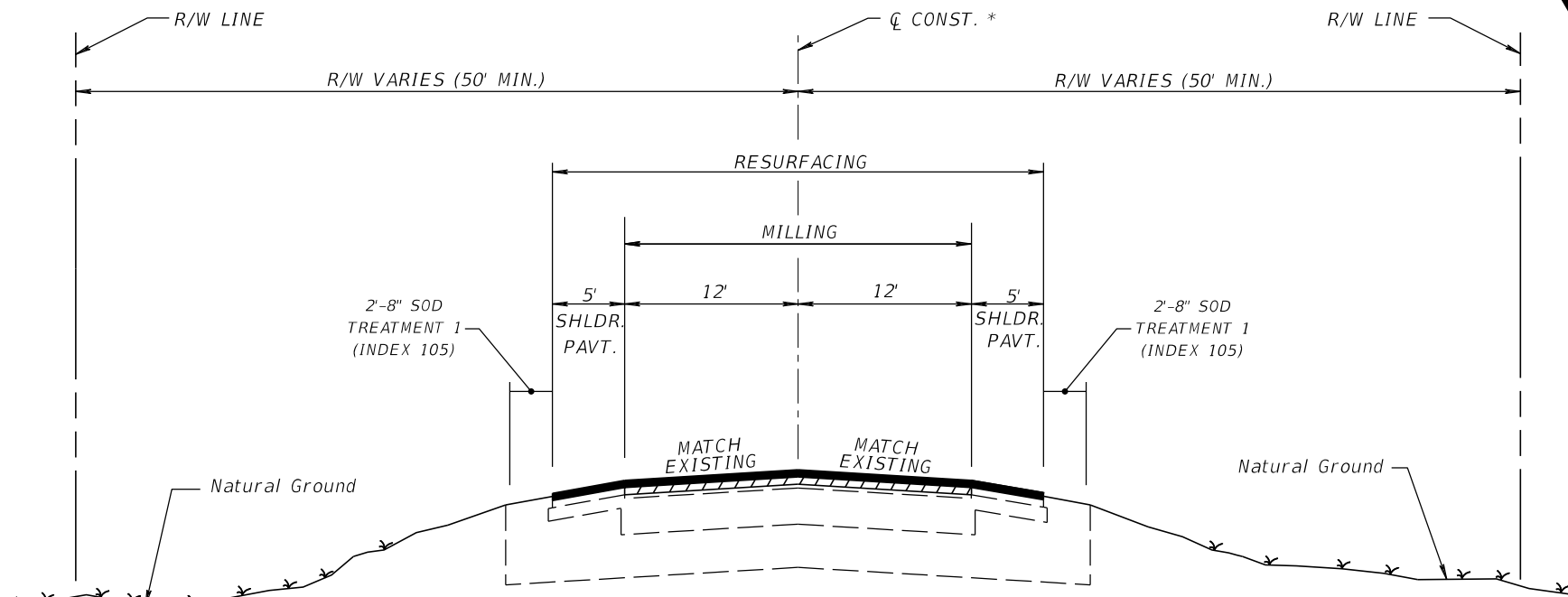

TYPICAL SECTION
SR 300B

SOME PROJECTS MAY REQUIRE SHOULDER WORK.
WHEN REQUIRED THIS SHOULD BE IDENTIFIED
ON THE TYPICAL SECTION SHEET.

TRAFFIC DATA
STA. 10+53.00 TO STA. 368+41.21
CURRENT YEAR = 1998 AADT = 9670
ESTIMATED OPENING YEAR = 2000 AADT = 11900
ESTIMATED DESIGN YEAR = 2010 AADT = 20200
K = 10% D = 60% T = 7% (24 HOUR)
DESIGN HOUR T = 3%
DESIGN SPEED = 55 MPH

CONSTANT DEPTH MILLING AND RESURFACING
STA. 10+53.00 TO STA. 368+41.21

MILLING

MILL EXISTING ASPHALT
PAVEMENT FOR DEPTH (2")

RESURFACING

TYPE SP STRUCTURAL COURSE (TRAFFIC B) (2")
AND FRICTION COURSE FC-9.5
(TRAFFIC B) (1") (PG 76-22)

SHOULDER PAVEMENT RESURFACING

FRICTION COURSE FC-9.5
(TRAFFIC B) (1") (PG 76-22)

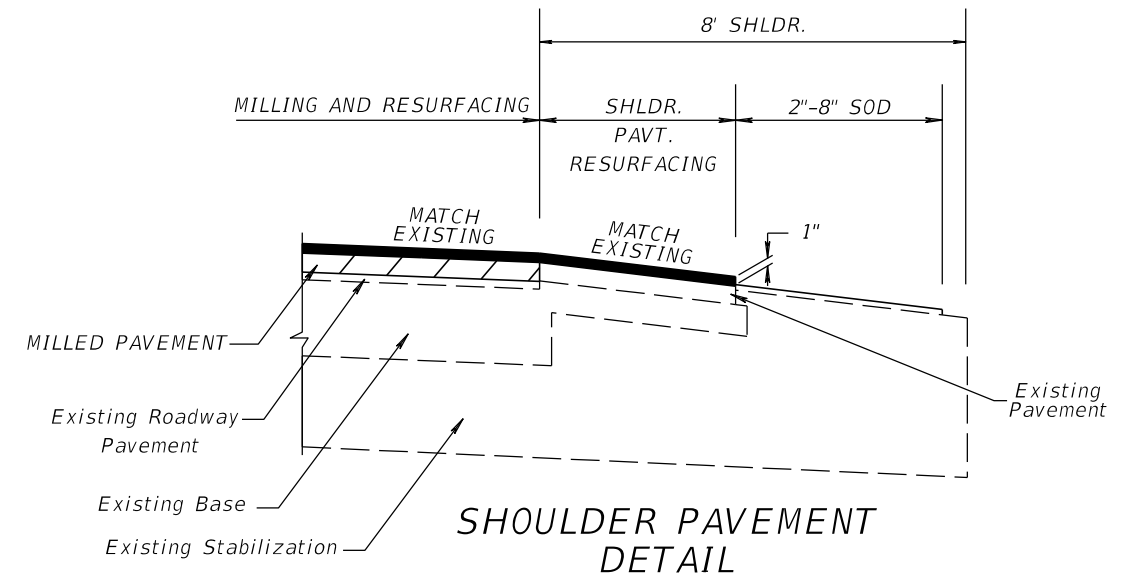

SHOULDER PAVEMENT
DETAIL

TRAFFIC DATA IS REQUIRED TO BE NOTED FOR
CURRENT YEAR, OPENING YEAR AND DESIGN YEAR.

EXHIBIT TYP-7
Date: 1/1/17

REVISIONS				STATE OF FLORIDA DEPARTMENT OF TRANSPORTATION			SHEET NO.
DATE	DESCRIPTION	DATE	DESCRIPTION	ROAD NO.	COUNTY	FINANCIAL PROJECT ID	
				22	BAY	123456-1-52-01	TYPICAL SECTION

* \varnothing SURVEY AND/OR
 \varnothing CONSTRUCTION, AS APPLICABLE.

FOR STANDARD TYPICAL SECTION NOTES
REFER TO EXHIBIT 6-1, THIS CHAPTER.

NOTES:
1. CROSS SLOPE CORRECTION IS REQUIRED IF
EXISTING CONDITIONS ARE NOT WITHIN THE RANGES OF
PPM VOLUME 1, CHAPTER 25 CRITERIA.
2. WHEN CROSS SLOPE CORRECTION IS NECESSARY,
SPECIAL MILLING, OVERBUILD, AND LAYERING DETAILS
MUST BE PROVIDED TO SUPPLEMENT TYPICAL SECTION.
THE NEED FOR AND LOCATION OF PROFILE GRADE
POINTS WILL DEPEND ON SITE SPECIFIC CONDITIONS.

EXISTING
2-LANE (2-WAY)
ARTERIAL/COLLECTOR
MILLING AND RESURFACING
UNDIVIDED
RURAL
(WITH EXISTING BIKE LANES
OR PAVED SHOULDERS)
WITH PROJECTED 20 YR.
AADT OF 1500 OR GREATER

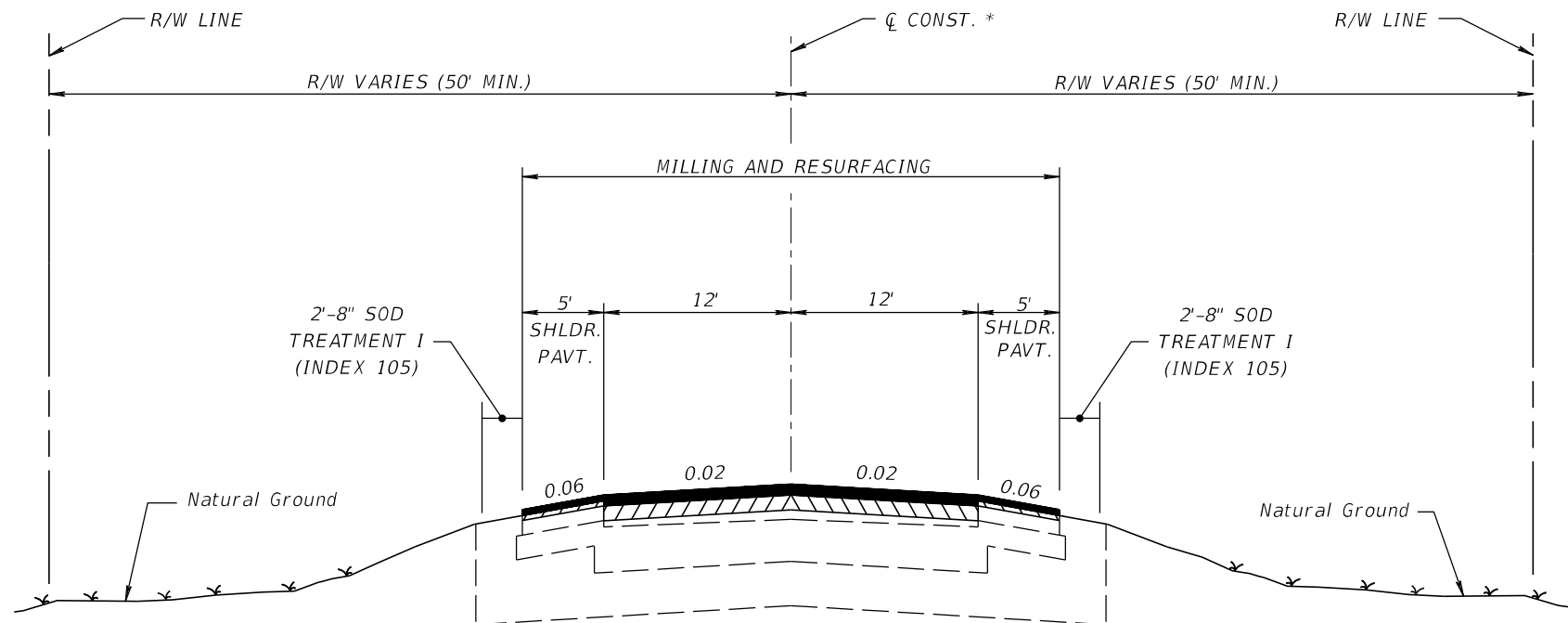

TYPICAL SECTION
SR 400B

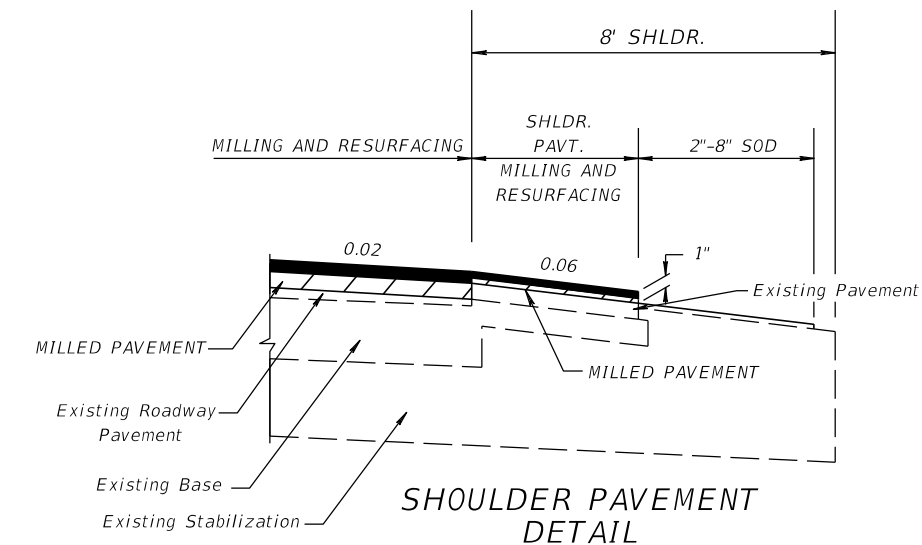

TRAFFIC DATA
STA. 130+77.00 TO STA. 206+82.28
CURRENT YEAR = 1998 AADT = 9670
ESTIMATED OPENING YEAR = 2000 AADT = 11900
ESTIMATED DESIGN YEAR = 2010 AADT = 20200
K = 10% D = 60% T = 7% (24 HOUR)
DESIGN HOUR T = 3%
DESIGN SPEED = 55 MPH

CROSS SLOPE CORRECTION
STA. 130+77.00 TO STA. 157+00.00
VARIABLE MILLING
MILL EXISTING ASPHALT
PAVEMENT FOR SLOPE (2 $\frac{3}{4}$ " AVG. DEPTH)

RESURFACING
TYPE SP STRUCTURAL COURSE (TRAFFIC B) (2")
AND FRICTION COURSE FC-9.5
(TRAFFIC B) (1") (PG 76-22)

SHOULDER MILLING
MILL EXISTING ASPHALT
PAVEMENT (1" AVG. DEPTH)

SHOULDER PAVEMENT RESURFACING
FRICTION COURSE FC-9.5
(TRAFFIC B) (1") (PG 76-22)

TRAFFIC DATA IS REQUIRED TO BE NOTED FOR
CURRENT YEAR, OPENING YEAR AND DESIGN YEAR.

EXHIBIT TYP-8
Date: 1/1/17
SHEET 1 OF 2

REVISIONS				STATE OF FLORIDA DEPARTMENT OF TRANSPORTATION	SHEET NO.
DATE	DESCRIPTION	DATE	DESCRIPTION		
				SR 22 BAY 123456-1-52-01	

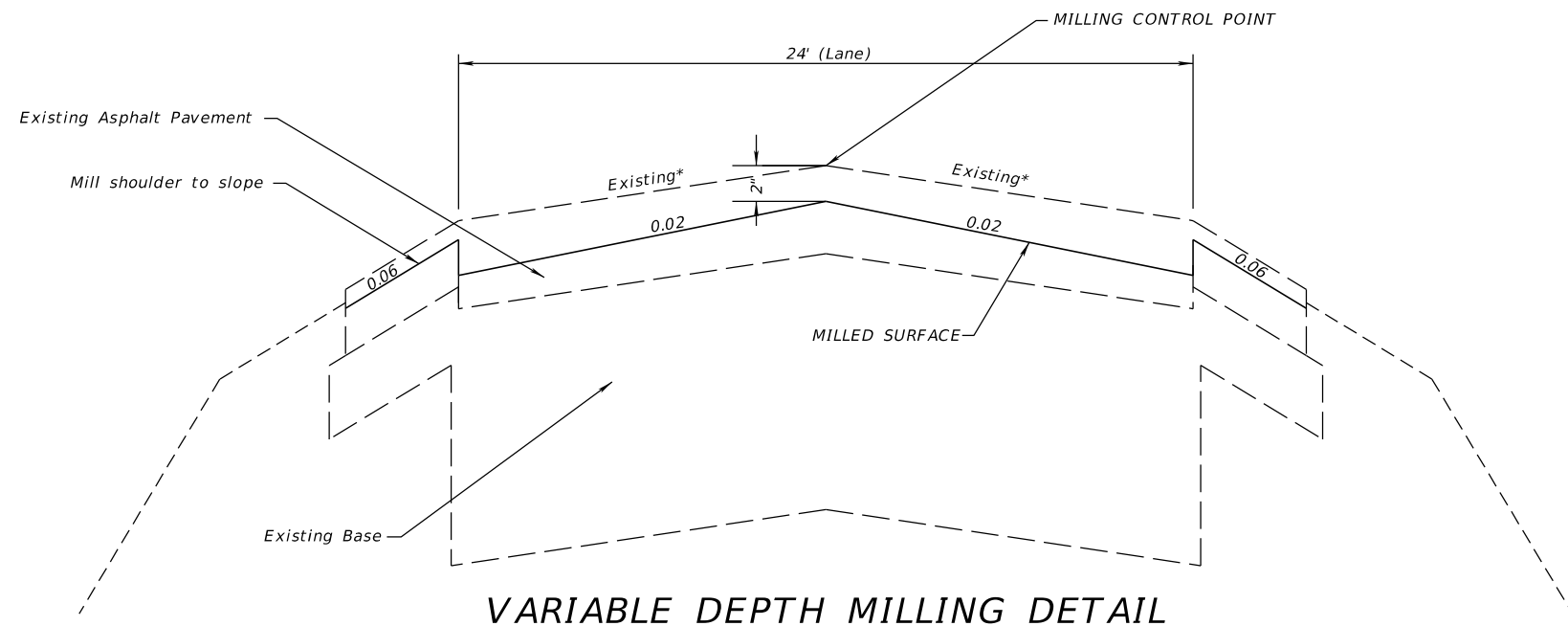

EXAMPLE OF CROSS SLOPE CORRECTION BY VARIABLE DEPTH MILLING AND RESURFACE.

WHEN CROSS SLOPE CORRECTION IS NECESSARY SPECIAL MILLING, OVERBUILD AND LAYERING DETAILS MUST BE PROVIDED TO SUPPLEMENT TYPICAL SECTION. THE NEED FOR AND LOCATION OF PROFILE GRADES POINTS WILL DEPEND ON SITE SPECIFIC CONDITIONS.

FOR STANDARD TYPICAL SECTION NOTES REFER TO EXHIBIT 6-1, THIS CHAPTER.

SUGGESTED CONSTRUCTION SEQUENCES SHOWN. OTHER SEQUENCES THAT MEET SPECIFICATIONS, THICKNESS AND CROSS SLOPE REQUIREMENTS MAY BE CONSIDERED BY THE ENGINEER.

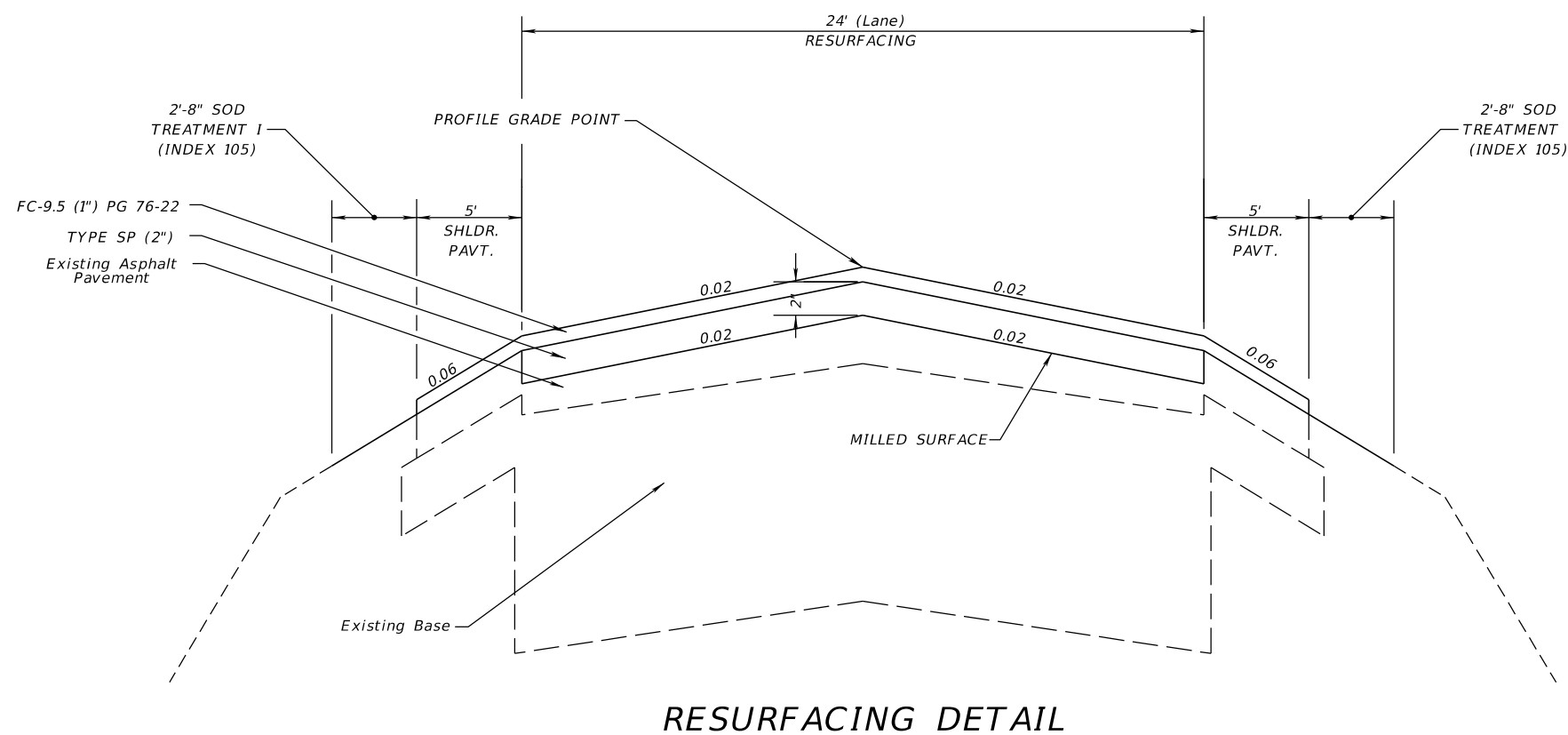

STA. 130+77.00 TO STA. 157+00.00

***EXISTING PAVEMENT CROSS SLOPES**

STATION	ROADWAY	
	LT	RT
131+00	0.014	0.014
132+00	0.014	0.014
133+00	0.013	0.013
134+00	0.013	0.012
135+00	0.013	0.013
136+00	0.013	0.013
137+00	0.012	0.013
138+00	0.012	0.013
139+00	0.013	0.014
140+00	0.012	0.013
141+00	0.013	0.011
142+00	0.014	0.011
143+00	0.015	0.011
144+00	0.015	0.011

***EXISTING PAVEMENT CROSS SLOPES**

STATION	ROADWAY	
	LT	RT
145+00	0.014	0.010
146+00	0.013	0.010
147+00	0.012	0.010
148+00	0.013	0.012
149+00	0.013	0.012
150+00	0.014	0.012
151+00	0.016	0.012
152+00	0.013	0.012
153+00	0.014	0.012
154+00	0.016	0.012
155+00	0.013	0.012
156+00	0.013	0.012
157+00	0.014	0.012

EXHIBIT TYP-8A
Date: 1/1/17
SHEET 2 OF 2

REVISIONS				STATE OF FLORIDA DEPARTMENT OF TRANSPORTATION			TYPICAL SECTION DETAILS	SHEET NO.
DATE	DESCRIPTION	DATE	DESCRIPTION	ROAD NO.	COUNTY	FINANCIAL PROJECT ID		
				22	BAY	123456-1-52-01		

THE OFFICIAL RECORD OF THIS SHEET IS THE ELECTRONIC FILE DIGITALLY SIGNED AND SEALED UNDER RULE 61G15-23.004, F.A.C.

* \varnothing SURVEY AND/OR
 \varnothing CONSTRUCTION, AS APPLICABLE.

FOR STANDARD TYPICAL SECTION NOTES
REFER TO EXHIBIT 6-1, THIS CHAPTER.

NOTES:
1. NO CROSS SLOPE CORRECTION REQUIRED IF EXISTING
CONDITIONS ARE WITHIN THE RANGES OF PPM VOLUME 1,
CHAPTER 25 CRITERIA.
2. WHEN CROSS SLOPE CORRECTION IS NECESSARY,
SPECIAL MILLING, OVERBUILD, AND LAYERING DETAILS
MUST BE PROVIDED TO SUPPLEMENT TYPICAL SECTION.
THE NEED FOR AND LOCATION OF PROFILE GRADE
POINTS WILL DEPEND ON SITE SPECIFIC CONDITIONS.

EXISTING
2-LANE (2-WAY)
ARTERIAL/COLLECTOR
MILLING AND OVERBUILD
FOR SLOPE
UNDIVIDED
RURAL
(WITH EXISTING BIKE LANES
OR PAVED SHOULDERS)
WITH PROJECTED 20 YR.
AADT OF 1500 OR GREATER

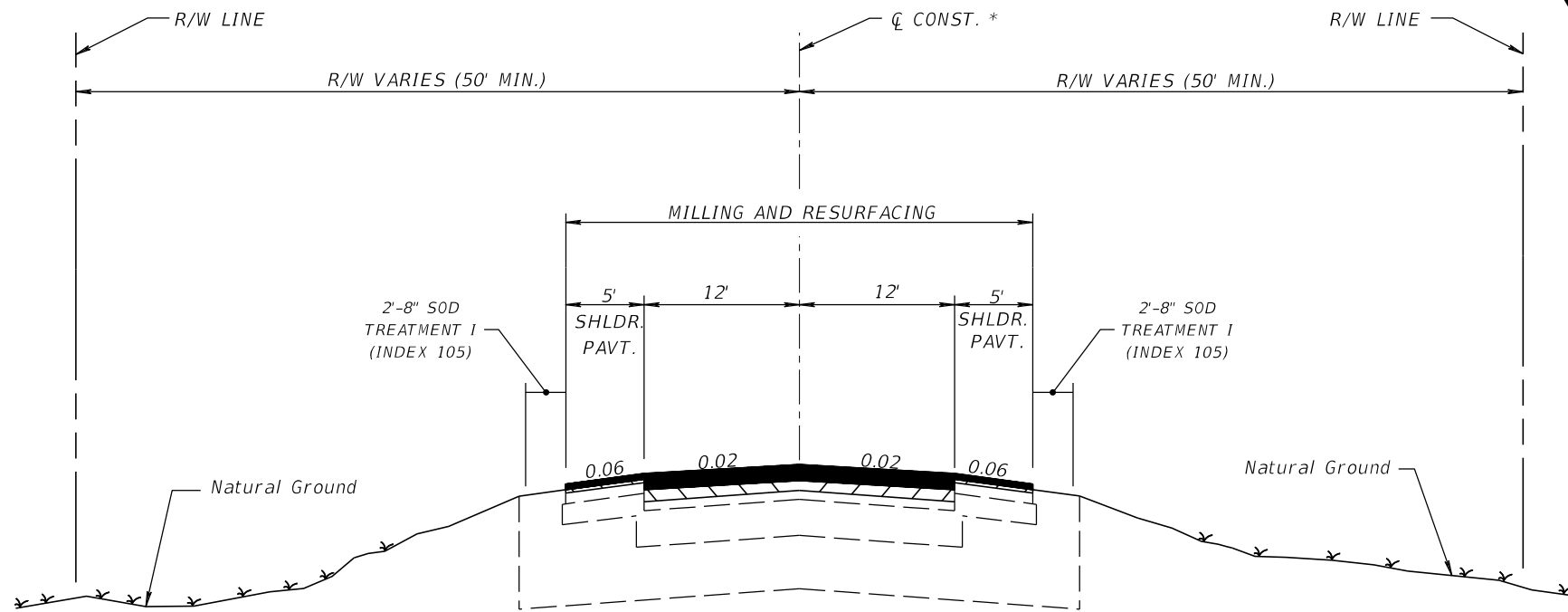

TYPICAL SECTION
SR 500B

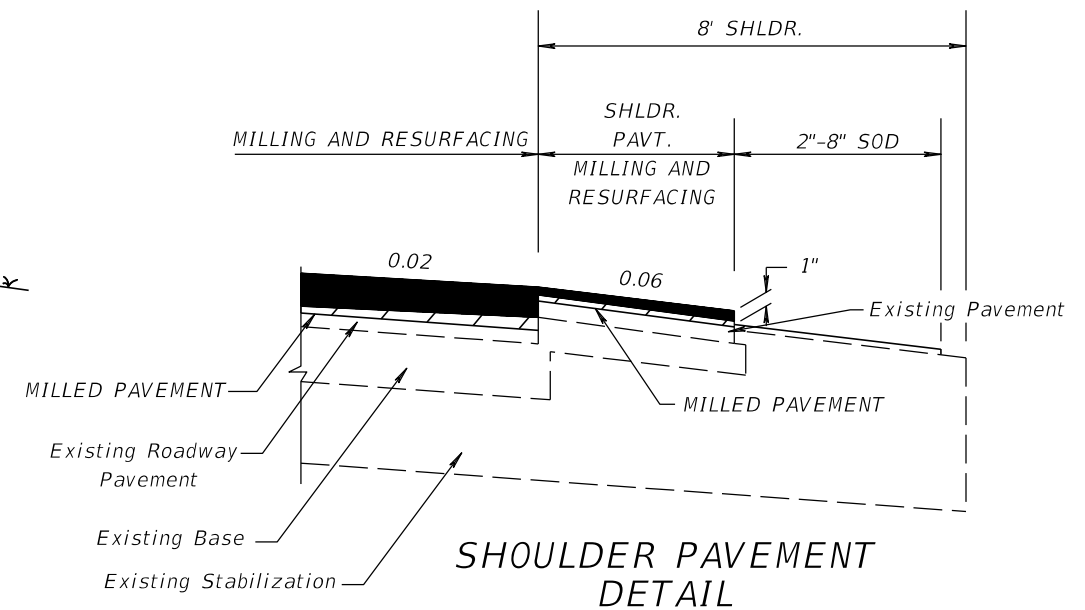

SHOULDER PAVEMENT
DETAIL

TRAFFIC DATA
STA. 10+53.00 TO STA. 130+77.00
CURRENT YEAR = 1998 AADT = 9670
ESTIMATED OPENING YEAR = 2000 AADT = 11900
ESTIMATED DESIGN YEAR = 2010 AADT = 20200
K = 10% D = 60% T = 7% (24 HOUR)
DESIGN HOUR T = 3%
DESIGN SPEED = 55 MPH

CROSS SLOPE CORRECTION
STA. 10+53.00 TO STA. 130+77.00
MILLING FOR DEPTH
MILL EXISTING ASPHALT
PAVEMENT FOR DEPTH (2")

OVERBUILD FOR SLOPE
TYPE SP OVERBUILD (TRAFFIC B)
THICKNESS VARIES ($\frac{3}{8}$ " TO $1\frac{1}{2}$ ")

RESURFACING
TYPE SP STRUCTURAL COURSE (TRAFFIC B) (2")
AND FRICTION COURSE FC-9.5
(TRAFFIC B) (1") (PG 76-22)

SHOULDER MILLING
MILL EXISTING ASPHALT
PAVEMENT (1" AVG. DEPTH)

SHOULDER PAVEMENT RESURFACING
FRICTION COURSE FC-9.5
(TRAFFIC B) (1") (PG 76-22)

TRAFFIC DATA IS REQUIRED TO BE NOTED FOR
CURRENT YEAR, OPENING YEAR AND DESIGN YEAR.

EXHIBIT TYP-9
Date: 1/1/17

SHEET 1 OF 2

REVISIONS				STATE OF FLORIDA DEPARTMENT OF TRANSPORTATION			TYPICAL SECTION	SHEET NO.
DATE	DESCRIPTION	DATE	DESCRIPTION	ROAD NO.	COUNTY	FINANCIAL PROJECT ID		
				22	BAY	123456-1-52-01		

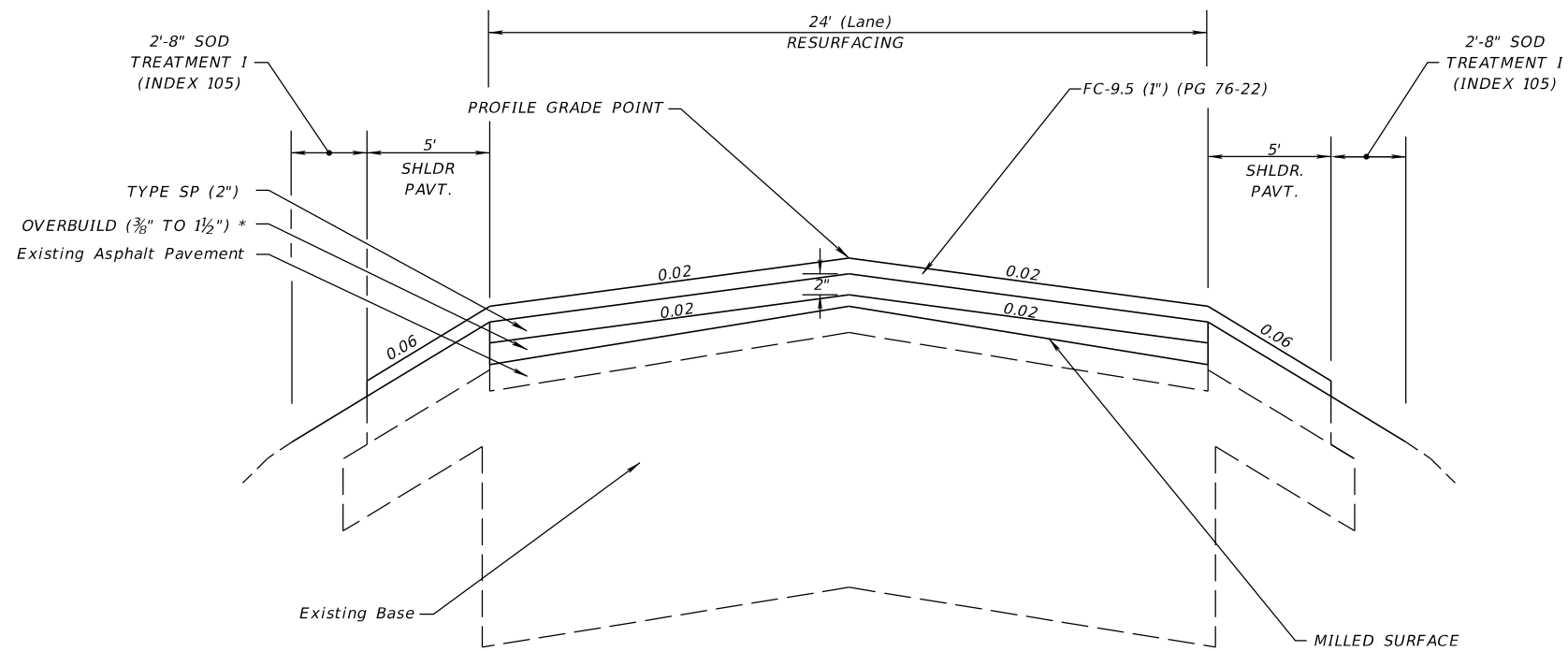

OVERBUILD AND RESURFACING DETAIL

* TYPE SP OVERBUILD THICKNESSES
(PER FDOT SPECIFICATION 334)

EXAMPLE OF CROSS SLOPE CORRECTION BY
CONSTANT DEPTH MILLING AND OVERBUILD.

WHEN CROSS SLOPE CORRECTION IS NECESSARY
SPECIAL MILLING, OVERBUILD AND LAYERING DETAILS
MUST BE PROVIDED TO SUPPLEMENT TYPICAL SECTION.
THE NEED FOR AND LOCATION OF PROFILE GRADES
POINTS WILL DEPEND ON SITE SPECIFIC CONDITIONS.

SUGGESTED CONSTRUCTION SEQUENCES SHOWN.
OTHER SEQUENCES THAT MEET SPECIFICATIONS,
THICKNESS AND CROSS SLOPE REQUIREMENTS MAY
BE CONSIDERED BY THE ENGINEER.

FOR STANDARD TYPICAL SECTION NOTES
REFER TO EXHIBIT 6-1, THIS CHAPTER.

EXHIBIT TYP-9A
Date: 1/1/17
SHEET 2 OF 2

REVISIONS				STATE OF FLORIDA DEPARTMENT OF TRANSPORTATION			TYPICAL SECTION DETAILS	SHEET NO.
DATE	DESCRIPTION	DATE	DESCRIPTION	ROAD NO.	COUNTY	FINANCIAL PROJECT ID		
				22	BAY	123456-1-52-01		

THE OFFICIAL RECORD OF THIS SHEET IS THE ELECTRONIC FILE DIGITALLY SIGNED AND SEALED UNDER RULE 61G15-23.004, F.A.C.

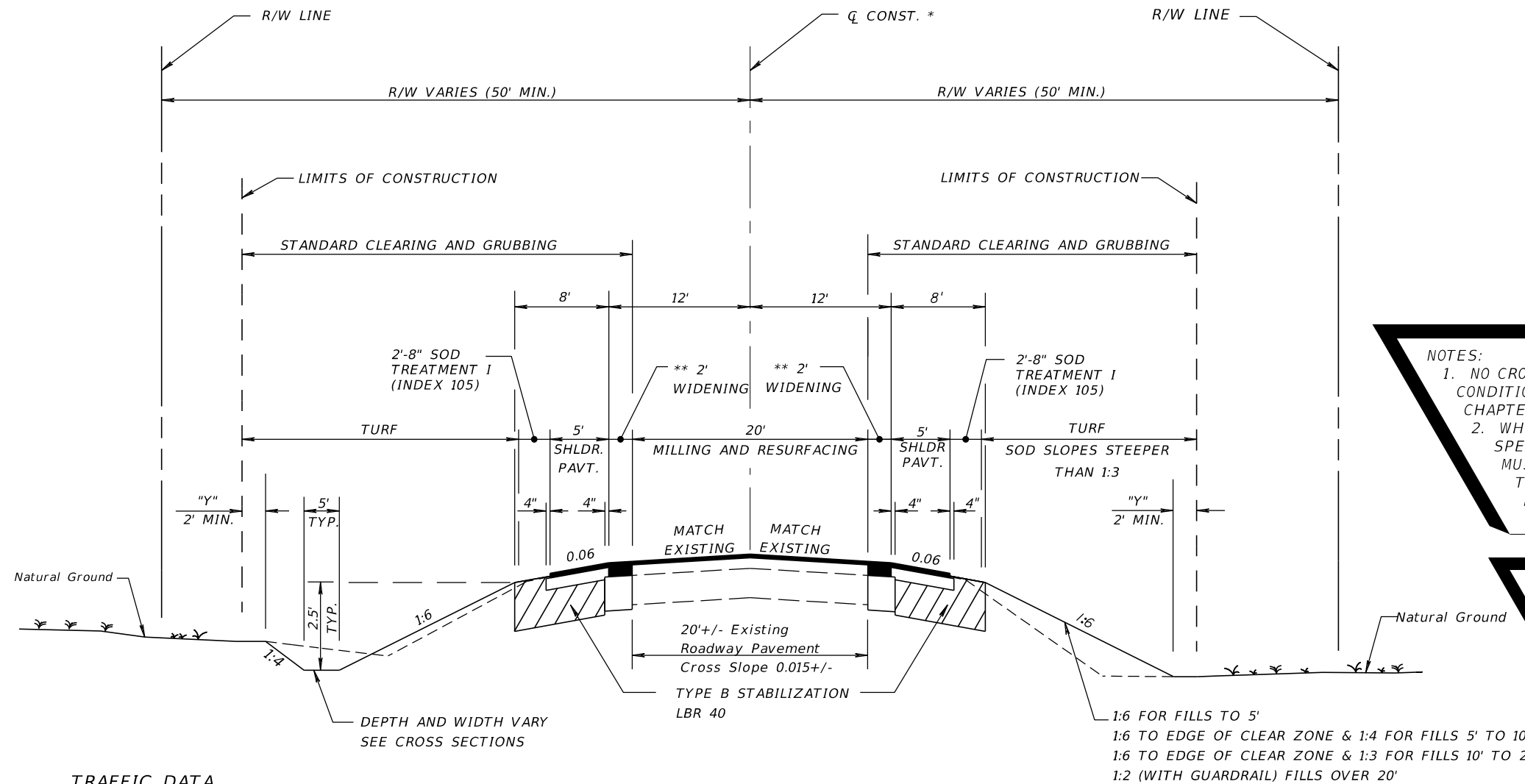

EXISTING
2-LANE (2-WAY)
ARTERIAL/COLLECTOR
WIDENING
MILLING AND RESURFACING
UNDIVIDED
RURAL
CONST. 5' SHOULDER
PAVEMENT OR BIKE LANE
WITH PROJECTED 20 YR.
AADT OF 1500 OR GREATER
DESIGN SPEED GREATER
THAN 50 MPH

NOTES:
1. NO CROSS SLOPE CORRECTION REQUIRED IF EXISTING CONDITIONS ARE WITHIN THE RANGES OF PPM VOLUME 1, CHAPTER 25 CRITERIA.
2. WHEN CROSS SLOPE CORRECTION IS NECESSARY, SPECIAL MILLING, OVERBUILD, AND LAYERING DETAILS MUST BE PROVIDED TO SUPPLEMENT TYPICAL SECTION. THE NEED FOR AND LOCATION OF PROFILE GRADE POINTS WILL DEPEND ON SITE SPECIFIC CONDITIONS.

* \bar{Q} SURVEY AND/OR \bar{Q} CONSTRUCTION, AS APPLICABLE.

"Y" THE AREA DISTURBED BY CONSTRUCTION VARIES.

NOTE:
HEIGHT OF FILL IS THE VERTICAL DISTANCE FROM THE EDGE OF THE OUTSIDE TRAVEL LANE TO TOE OF FRONT SLOPE.

FOR STANDARD TYPICAL SECTION NOTES REFER TO EXHIBIT 6-1, THIS CHAPTER.

** SEE SHEET 2 OF 2 FOR WIDENING AND SHOULDER PAVEMENT DETAIL

EXHIBIT TYP-10
Date: 1/1/17
SHEET 1 OF 2

TRAFFIC DATA
STA. 20+25.00 TO STA. 48+16.56

CURRENT YEAR = 1998 AADT = 8700
ESTIMATED OPENING YEAR = 2000 AADT = 9200
ESTIMATED DESIGN YEAR = 2020 AADT = 23600
K = 10% D = 56% T = 5% (24 HOUR)
DESIGN HOUR T = 3%
DESIGN SPEED = 55 MPH

STA. 57+82.78 TO STA. 93+41.21

CURRENT YEAR = 1998 AADT = 6835
ESTIMATED OPENING YEAR = 2000 AADT = 8600
ESTIMATED DESIGN YEAR = 2020 AADT = 17200
K = 10% D = 65% T = 7% (24 HOUR)
DESIGN HOUR T = 3%
DESIGN SPEED = 55 MPH

TRAFFIC DATA IS REQUIRED TO BE NOTED FOR CURRENT YEAR, OPENING YEAR AND DESIGN YEAR.

TYPICAL SECTION
SR 000
STA. 20+25.00 TO STA. 48+16.56
STA. 57+82.78 TO STA. 93+41.21

MILLING
MILL EXISTING ASPHALT PAVEMENT FOR DEPTH (2")

RESURFACING
TYPE SP STRUCTURAL COURSE (TRAFFIC C) (1 1/2")
AND FRICTION COURSE FC-12.5 (TRAFFIC C) (1 1/2") (PG 76-22)

WIDENING
OPTIONAL BASE GROUP 11 WITH
TYPE SP STRUCTURAL COURSE (TRAFFIC C) (3")
AND FRICTION COURSE FC-12.5 (TRAFFIC C) (1 1/2") (PG 76-22)

REVISIONS				STATE OF FLORIDA DEPARTMENT OF TRANSPORTATION			SHEET NO.
DATE	DESCRIPTION	DATE	DESCRIPTION	ROAD NO.	COUNTY	FINANCIAL PROJECT ID	
				22	BAY	123456-1-52-01	

TYPICAL SECTION

THE OFFICIAL RECORD OF THIS SHEET IS THE ELECTRONIC FILE DIGITALLY SIGNED AND SEALED UNDER RULE 61G15-23.004, F.A.C.

THE NEED FOR STABILIZATION IN THE SHOULDER AREA ON RRR PROJECTS IS SITE SPECIFIC AND NOT ALWAYS REQUIRED. THE USE OF STABILIZING IN NARROW TRENCH WIDENING STRIPS IS NOT RECOMMENDED GENERALLY. SEE THE FLEXIBLE PAVEMENT DESIGN MANUAL FOR FURTHER CRITERIA.

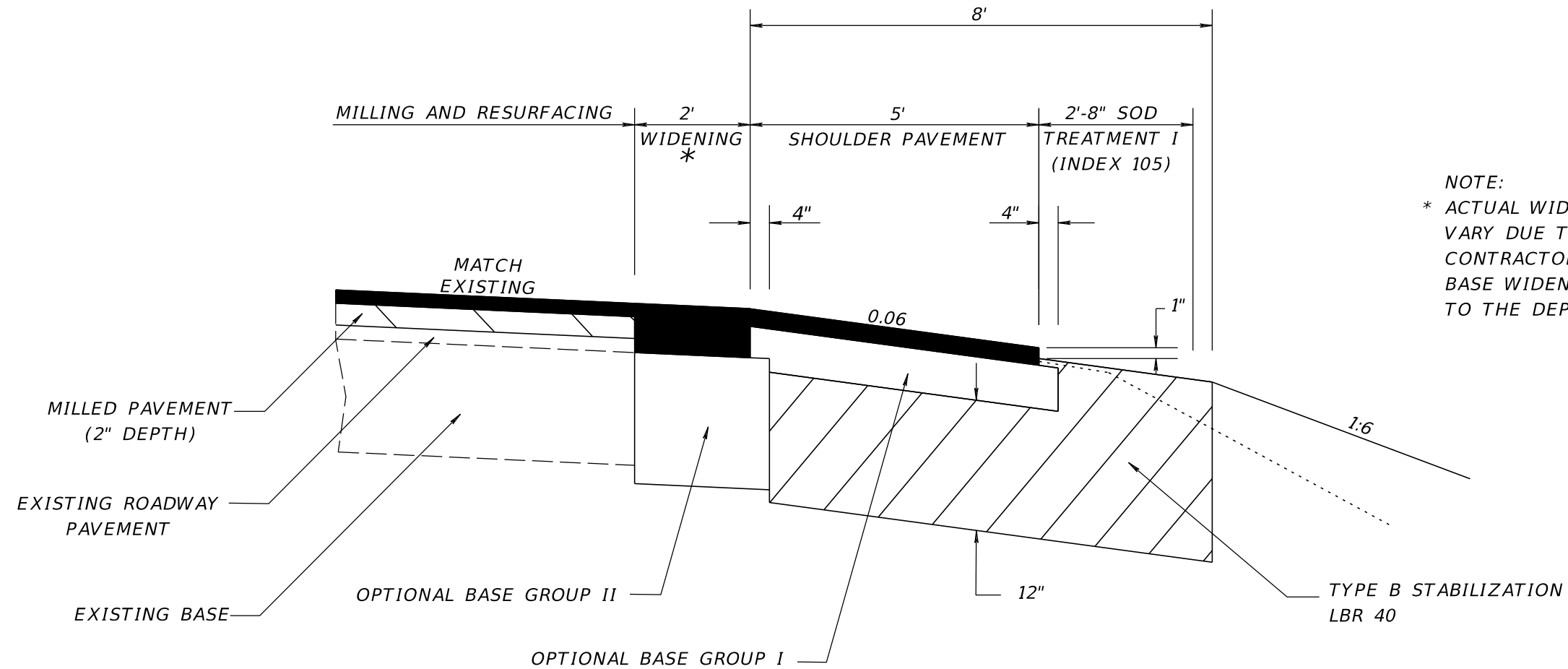

NOTE:
* ACTUAL WIDTH OF BASE WIDENING MAY VARY DUE TO ACTUAL PAVEMENT WIDTH. CONTRACTOR MAY ELECT TO PLACE UNIFORM BASE WIDENING AT NO ADDITIONAL COST TO THE DEPARTMENT.

WIDENING & SHOULDER PAVEMENT DETAIL

WIDENING

OPTIONAL BASE GROUP II WITH
TYPE SP STRUCTURAL COURSE (TRAFFIC C) (3")
FRICTION COURSE FC-12.5 (TRAFFIC C) (1 1/2") (PG 76-22)

SHOULDER PAVEMENT

OPTIONAL BASE GROUP I WITH
FRICTION COURSE FC-12.5 (TRAFFIC C) (1 1/2") (PG 76-22)

NOTES:
1. NO CROSS SLOPE CORRECTION REQUIRED IF EXISTING CONDITIONS ARE WITHIN THE RANGES OF PPM VOLUME 1, CHAPTER 25 CRITERIA.
2. WHEN CROSS SLOPE CORRECTION IS NECESSARY, SPECIAL MILLING, OVERBUILD, AND LAYERING DETAILS MUST BE PROVIDED TO SUPPLEMENT TYPICAL SECTION. THE NEED FOR AND LOCATION OF PROFILE GRADE POINTS WILL DEPEND ON SITE SPECIFIC CONDITIONS.

FOR STANDARD TYPICAL SECTION NOTES REFER TO EXHIBIT 6-1, THIS CHAPTER

EXHIBIT TYP-10A
Date: 1/1/17
SHEET 2 OF 2

REVISIONS				STATE OF FLORIDA DEPARTMENT OF TRANSPORTATION			TYPICAL SECTION	SHEET NO.
DATE	DESCRIPTION	DATE	DESCRIPTION	ROAD NO.	COUNTY	FINANCIAL PROJECT ID		
				SR 22	BAY	123456-1-52-01		

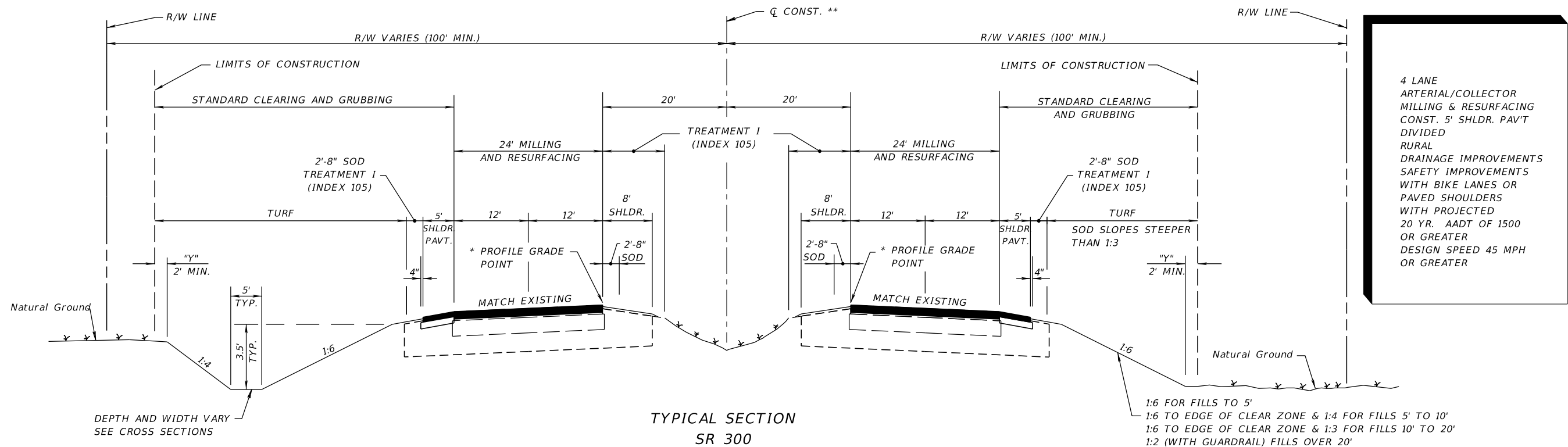

4 LANE
ARTERIAL/COLLECTOR
MILLING & RESURFACING
CONST. 5' SHLDR. PAV'T
DIVIDED
RURAL
DRAINAGE IMPROVEMENTS
SAFETY IMPROVEMENTS
WITH BIKE LANES OR
PAVED SHOULDERS
WITH PROJECTED
20 YR. AADT OF 1500
OR GREATER
DESIGN SPEED 45 MPH
OR GREATER

TYPICAL SECTION
SR 300

CONSTANT DEPTH MILLING AND RESURFACING
STA. 190+00.00 TO STA. 204+34.58

- MILLING**
MILL EXISTING ASPHALT PAVEMENT FOR DEPTH (1 1/2")
- RESURFACING**
TYPE SP STRUCTURAL COURSE (TRAFFIC D) (1 1/2")
TYPE SP STRUCTURAL COURSE (TRAFFIC D) (1 1/2") (PG 76-22)
AND FRICTION COURSE FC-5 (3/4") (PG 76-22)
- SHOULDER PAVEMENT**
OPTIONAL BASE GROUP 1 WITH
TYPE SP STRUCTURAL COURSE (TRAFFIC D) (1 1/2") (PG 76-22)
AND FRICTION COURSE FC-5 (3/4") (PG 76-22)

TRAFFIC DATA

CURRENT YEAR = 1998 AADT = 18100
ESTIMATED OPENING YEAR = 2000 AADT = 21000
ESTIMATED DESIGN YEAR = 2012 AADT = 38900
K = 11% D = 58% T = 22% (24 HOUR)
DESIGN HOUR T = 11%
DESIGN SPEED = 60 MPH
POSTED SPEED = 55 MPH

TRAFFIC DATA IS REQUIRED TO BE NOTED FOR
CURRENT YEAR, OPENING YEAR, AND DESIGN YEAR.
POSTED SPEED (MPH) IS OPTIONAL.

** \bar{Q} SURVEY AND/OR
 \bar{Q} CONSTRUCTION, AS APPLICABLE.

* WHEN CROSS SLOPE CORRECTION IS NECESSARY
SPECIAL MILLING, OVERBUILD AND LAYERING DETAILS
MUST BE PROVIDED TO SUPPLEMENT TYPICAL SECTION.
THE NEED FOR AND LOCATION OF PROFILE GRADE
POINTS WILL DEPEND ON SITE SPECIFIC CONDITIONS.

"Y" THE AREA DISTURBED BY CONSTRUCTION VARIES.

FOR STANDARD TYPICAL SECTION NOTES
REFER TO EXHIBIT 6-1, THIS CHAPTER.

NOTE:
HEIGHT OF FILL IS THE VERTICAL DISTANCE
FROM THE EDGE OF THE OUTSIDE TRAVEL LANE
TO TOE OF FRONT SLOPE.

FOR MILLING AND RESURFACING DETAILS SEE
TYPICAL SECTION DETAILS SHEET 2-5

EXHIBIT TYP-11
Date: 1/1/14

SHEET 1 OF 1

REVISIONS				STATE OF FLORIDA DEPARTMENT OF TRANSPORTATION			SHEET NO.
DATE	DESCRIPTION	DATE	DESCRIPTION	ROAD NO.	COUNTY	FINANCIAL PROJECT ID	
				22	BAY	123456-1-52-01	

TYPICAL SECTION

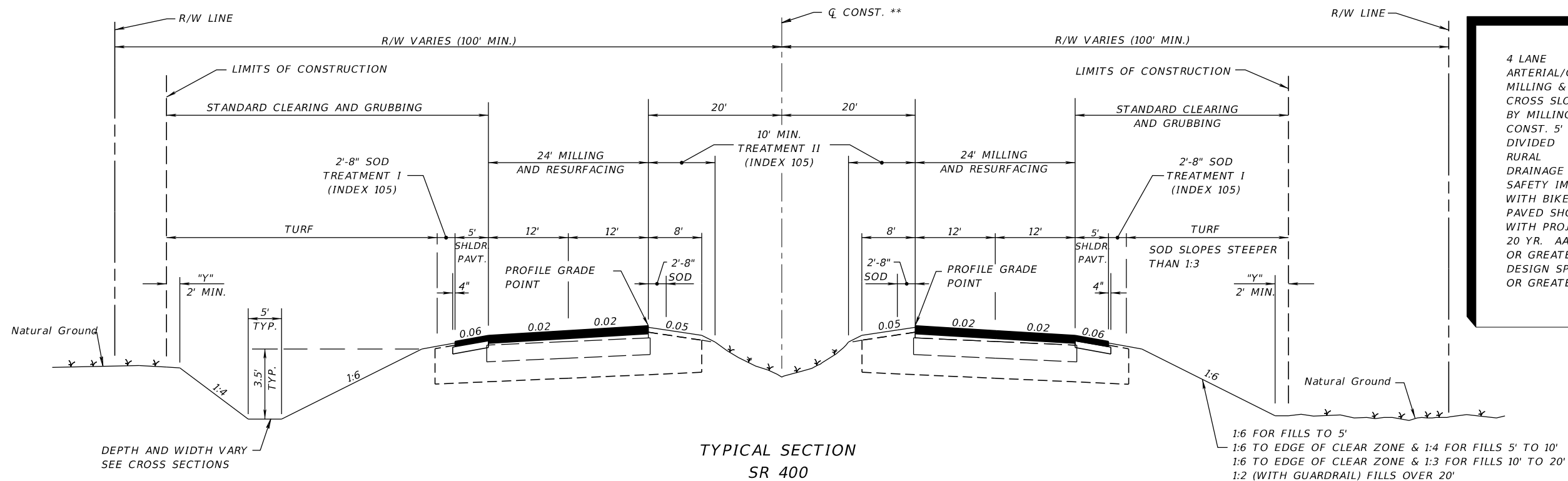

4 LANE ARTERIAL/COLLECTOR MILLING & RESURFACING CROSS SLOPE CORRECTION BY MILLING CONST. 5' SHLDR. PAVT DIVIDED RURAL DRAINAGE IMPROVEMENTS SAFETY IMPROVEMENTS WITH BIKE LANES OR PAVED SHOULDERS WITH PROJECTED 20 YR. AADT OF 1500 OR GREATER DESIGN SPEED 45 MPH OR GREATER

TYPICAL SECTION SR 400

CROSS SLOPE CORRECTION
STA. 204+34.58 TO STA. 225+00.00
VARIABLE DEPTH MILLING
 MILL EXISTING ASPHALT PAVEMENT FOR SLOPE (1 1/2" AVG. DEPTH)

RESURFACING
 TYPE SP STRUCTURAL COURSE (TRAFFIC D) (1 1/2")
 TYPE SP STRUCTURAL COURSE (TRAFFIC D) (1 1/2") (PG 76-22)
 AND FRICTION COURSE FC-5 (3/4") (PG 76-22)

SHOULDER PAVEMENT
 OPTIONAL BASE GROUP 1 WITH
 TYPE SP STRUCTURAL COURSE (TRAFFIC D) (1 1/2") (PG 76-22)
 AND FRICTION COURSE FC-5 (3/4") (PG 76-22)

NOTES:
 1. CROSS SLOPE CORRECTION IS REQUIRED IF EXISTING CONDITIONS ARE NOT WITHIN THE RANGES OF PPM VOLUME 1, CHAPTER 25 CRITERIA.
 2. WHEN CROSS SLOPE CORRECTION IS NECESSARY, SPECIAL MILLING, OVERBUILD, AND LAYERING DETAILS MUST BE PROVIDED TO SUPPLEMENT TYPICAL SECTION. THE NEED FOR AND LOCATION OF PROFILE GRADE POINTS WILL DEPEND ON SITE SPECIFIC CONDITIONS.

NOTE:
 HEIGHT OF FILL IS THE VERTICAL DISTANCE FROM THE EDGE OF THE OUTSIDE TRAVEL LANE TO TOE OF FRONT SLOPE.

FOR MILLING AND RESURFACING DETAILS SEE TYPICAL SECTION DETAILS SHEET 2-5

EXHIBIT TYP-12
 Date: 1/1/14

SHEET 1 OF 2

"Y" THE AREA DISTURBED BY CONSTRUCTION VARIES.

TRAFFIC DATA
 CURRENT YEAR = 1998 AADT = 18100
 ESTIMATED OPENING YEAR = 2000 AADT = 21000
 ESTIMATED DESIGN YEAR = 2012 AADT = 38900
 K = 11% D = 58% T = 22% (24 HOUR)
 DESIGN HOUR T = 11%
 DESIGN SPEED = 60 MPH
 POSTED SPEED = 55 MPH

TRAFFIC DATA IS REQUIRED TO BE NOTED FOR CURRENT YEAR, OPENING YEAR, AND DESIGN YEAR. POSTED SPEED (MPH) IS OPTIONAL.

** \varnothing SURVEY AND/OR \varnothing CONSTRUCTION, AS APPLICABLE.

FOR STANDARD TYPICAL SECTION NOTES REFER TO EXHIBIT 6-1, THIS CHAPTER.

REVISIONS				STATE OF FLORIDA DEPARTMENT OF TRANSPORTATION			SHEET NO.
DATE	DESCRIPTION	DATE	DESCRIPTION	ROAD NO.	COUNTY	FINANCIAL PROJECT ID	
				22	BAY	123456-1-52-01	

TYPICAL SECTION

THE OFFICIAL RECORD OF THIS SHEET IS THE ELECTRONIC FILE DIGITALLY SIGNED AND SEALED UNDER RULE 61G15-23.004, F.A.C.

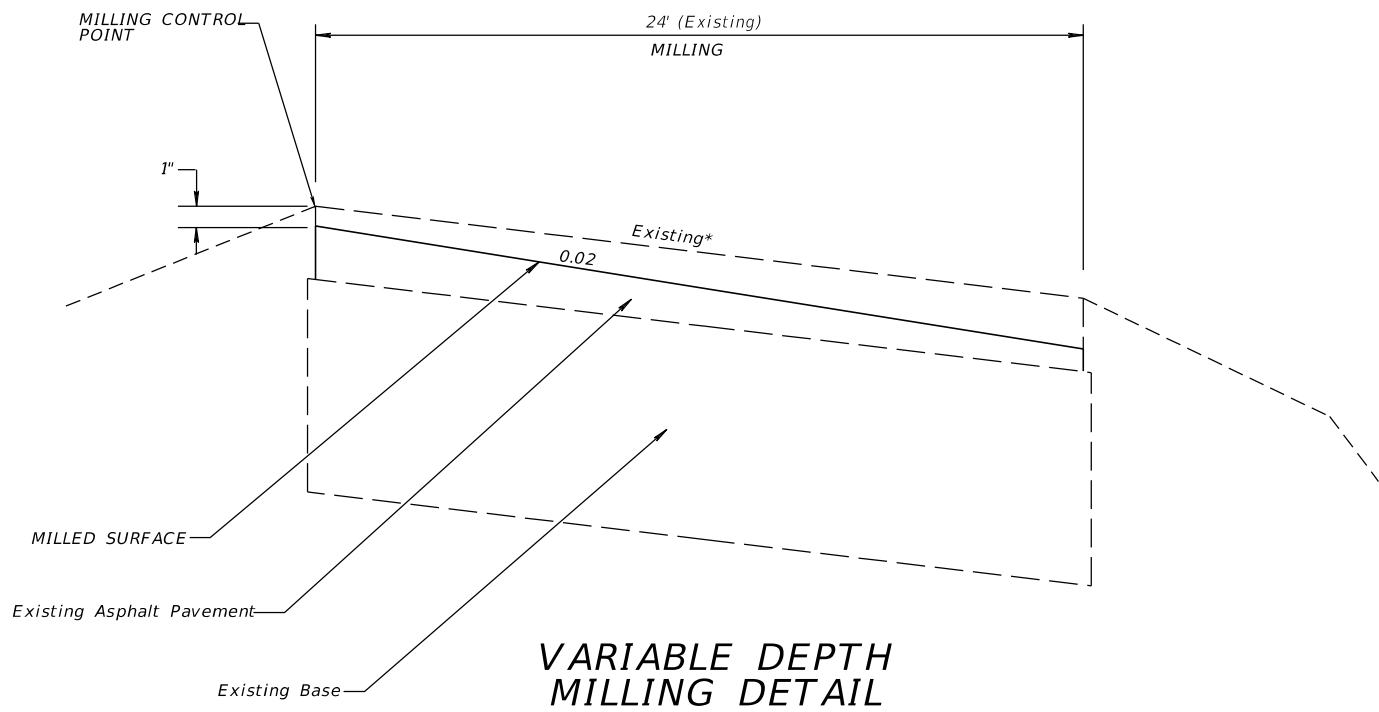

VARIABLE DEPTH MILLING DETAIL

EXAMPLE OF CROSS SLOPE CORRECTION BY MILLING AND PAVING WITH CONSTANT DEPTH.

WHEN CROSS SLOPE CORRECTION IS NECESSARY SPECIAL MILLING AND LAYERING DETAILS MUST BE PROVIDED TO SUPPLEMENT TYPICAL SECTION. THE NEED FOR AND LOCATION OF PROFILE GRADE POINTS WILL DEPEND ON SITE SPECIFIC CONDITIONS.

FOR STANDARD TYPICAL SECTION NOTES REFER TO EXHIBIT 6-1, THIS CHAPTER.

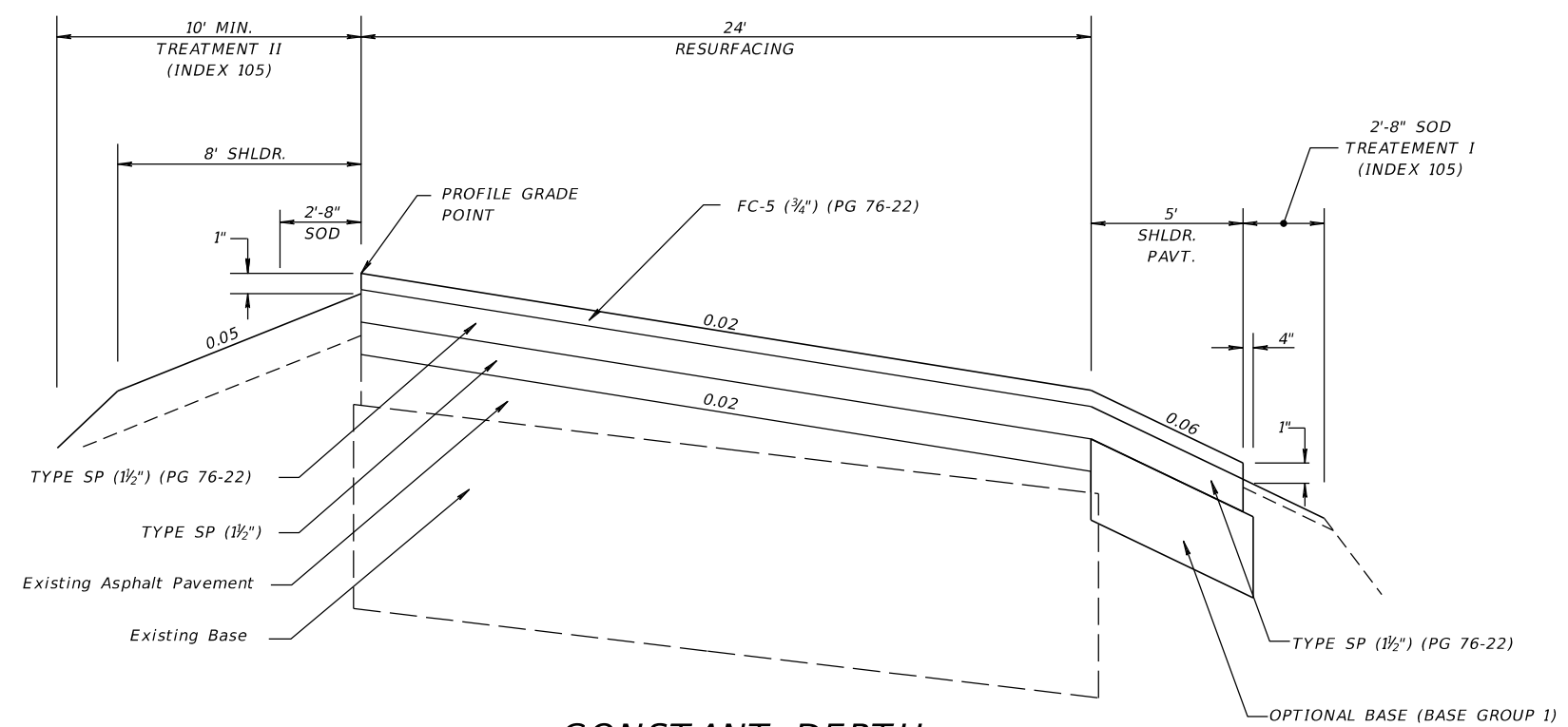

CONSTANT DEPTH RESURFACING DETAIL

STA. 204+34.58 TO STA. 225+00

*EXISTING PAVEMENT CROSS SLOPES		
STATION	EASTBOUND LANES	
	INSIDE	OUTSIDE
205+00	0.014	0.013
206+00	0.012	0.012
207+00	0.013	0.013
208+00	0.011	0.012
209+00	0.013	0.014
210+00	0.013	0.015
211+00	0.014	0.015
212+00	0.013	0.013
213+00	0.012	0.012
214+00	0.012	0.011
215+00	0.013	0.011
216+00	0.014	0.012
217+00	0.015	0.013

*EXISTING PAVEMENT CROSS SLOPES		
STATION	EASTBOUND LANES	
	INSIDE	OUTSIDE
218+00	0.015	0.013
219+00	0.014	0.014
220+00	0.013	0.016
221+00	0.012	0.015
222+00	0.013	0.014
223+00	0.013	0.013
224+00	0.014	0.013
225+00	0.016	0.016

EXHIBIT TYP-12A
Date: 1/1/14

SHEET 2 OF 2

REVISIONS				STATE OF FLORIDA DEPARTMENT OF TRANSPORTATION			TYPICAL SECTION DETAILS	SHEET NO.
DATE	DESCRIPTION	DATE	DESCRIPTION	ROAD NO.	COUNTY	FINANCIAL PROJECT ID		
				400	LEON	123456-1-52-01		

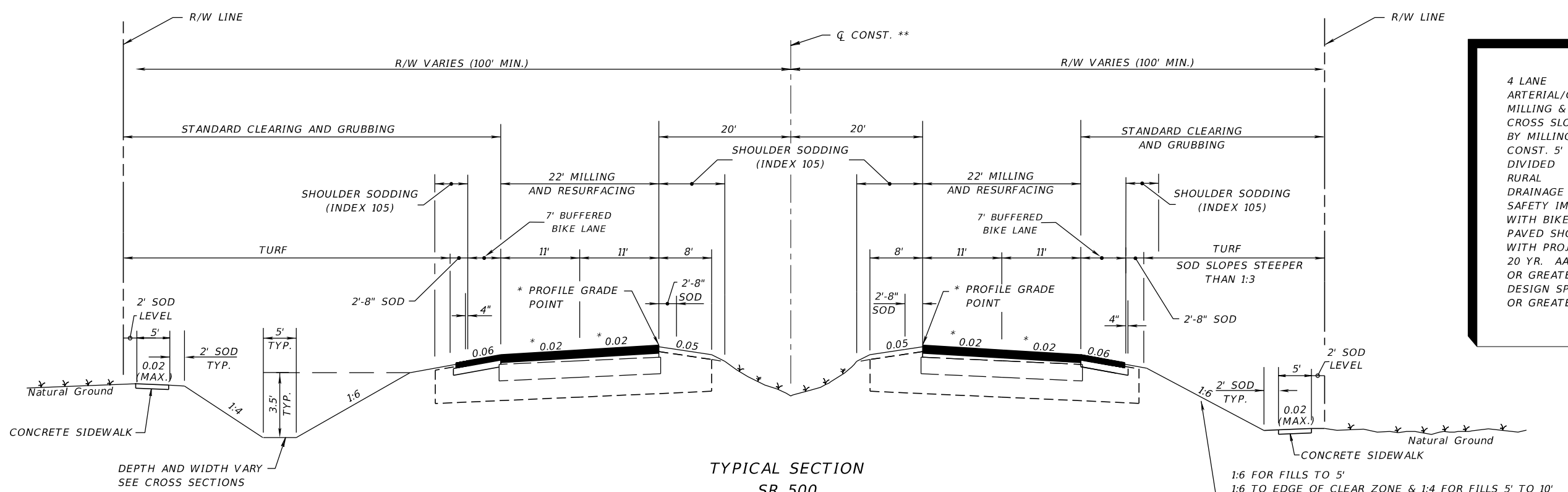

TYPICAL SECTION
SR 500

STA. 316+53.67 TO STA. 347+00.00
VARIABLE DEPTH MILLING
 MILL EXISTING ASPHALT PAVEMENT (1 1/2" AVG. DEPTH)

OVERBUILD
 TYPE SP OVERBUILD (TRAFFIC D) THICKNESS VARIES (1" TO 1 1/2")

RESURFACING
 TYPE SP STRUCTURAL COURSE (TRAFFIC D) (1 1/2")
 TYPE SP STRUCTURAL COURSE (TRAFFIC D) (1 1/2") (PG 76-22)
 AND FRICTION COURSE FC-5 (3/4") (PG 76-22)

SHOULDER PAVEMENT
 OPTIONAL BASE GROUP 1 WITH
 TYPE SP STRUCTURAL COURSE (TRAFFIC D) (1 1/2") (PG 76-22)
 AND FRICTION COURSE FC-5 (3/4") (PG 76-22)

STA. 600+10.00 TO STA. 620+00.00
CONSTANT DEPTH MILLING
 MILL EXISTING ASPHALT PAVEMENT (1 1/2" DEPTH)

OVERBUILD
 TYPE SP OVERBUILD (TRAFFIC D) THICKNESS VARIES (1" TO 2 1/2")

RESURFACING
 TYPE SP STRUCTURAL COURSE (TRAFFIC D) (1 1/2")
 TYPE SP STRUCTURAL COURSE (TRAFFIC D) (1 1/2") (PG 76-22)
 AND FRICTION COURSE FC-5 (3/4") (PG 76-22)

SHOULDER PAVEMENT
 OPTIONAL BASE GROUP 1 WITH
 TYPE SP STRUCTURAL COURSE (TRAFFIC D) (1 1/2") (PG 76-22)
 AND FRICTION COURSE FC-5 (3/4") (PG 76-22)

TRAFFIC DATA

CURRENT YEAR = 1998 AADT = 18100
 ESTIMATED OPENING YEAR = 2000 AADT = 21000
 ESTIMATED DESIGN YEAR = 2012 AADT = 38900
 K = 11% D = 58% T = 22% (24 HOUR)
 DESIGN HOUR T = 11%
 DESIGN SPEED = 60 MPH
 POSTED SPEED = 55 MPH

TRAFFIC DATA IS REQUIRED TO BE NOTED FOR
 CURRENT YEAR, OPENING YEAR, AND DESIGN YEAR.
 POSTED SPEED (MPH) IS OPTIONAL.

** \varnothing SURVEY AND/OR
 \varnothing CONSTRUCTION, AS APPLICABLE.

* WHEN CROSS SLOPE CORRECTION IS NECESSARY
 SPECIAL MILLING, OVERBUILD AND LAYERING DETAILS
 MUST BE PROVIDED TO SUPPLEMENT TYPICAL SECTION.
 THE NEED FOR AND LOCATION OF PROFILE GRADE
 POINTS WILL DEPEND ON SITE SPECIFIC CONDITIONS.

FOR STANDARD TYPICAL SECTION NOTES
 REFER TO EXHIBIT 6-1, THIS CHAPTER.

NOTE:
 HEIGHT OF FILL IS THE VERTICAL DISTANCE
 FROM THE EDGE OF THE OUTSIDE TRAVEL LANE
 TO TOE OF FRONT SLOPE.

FOR MILLING AND RESURFACING DETAILS SEE
 TYPICAL SECTION DETAILS SHEET 2-4

EXHIBIT TYP-13
 Date: 1/1/15

SHEET 1 OF 4

REVISIONS				STATE OF FLORIDA DEPARTMENT OF TRANSPORTATION			TYPICAL SECTION	SHEET NO.
DATE	DESCRIPTION	DATE	DESCRIPTION	ROAD NO.	COUNTY	FINANCIAL PROJECT ID		
				22	BAY	123456-1-52-01		

THE OFFICIAL RECORD OF THIS SHEET IS THE ELECTRONIC FILE DIGITALLY SIGNED AND SEALED UNDER RULE 61G15-23.004, F.A.C.

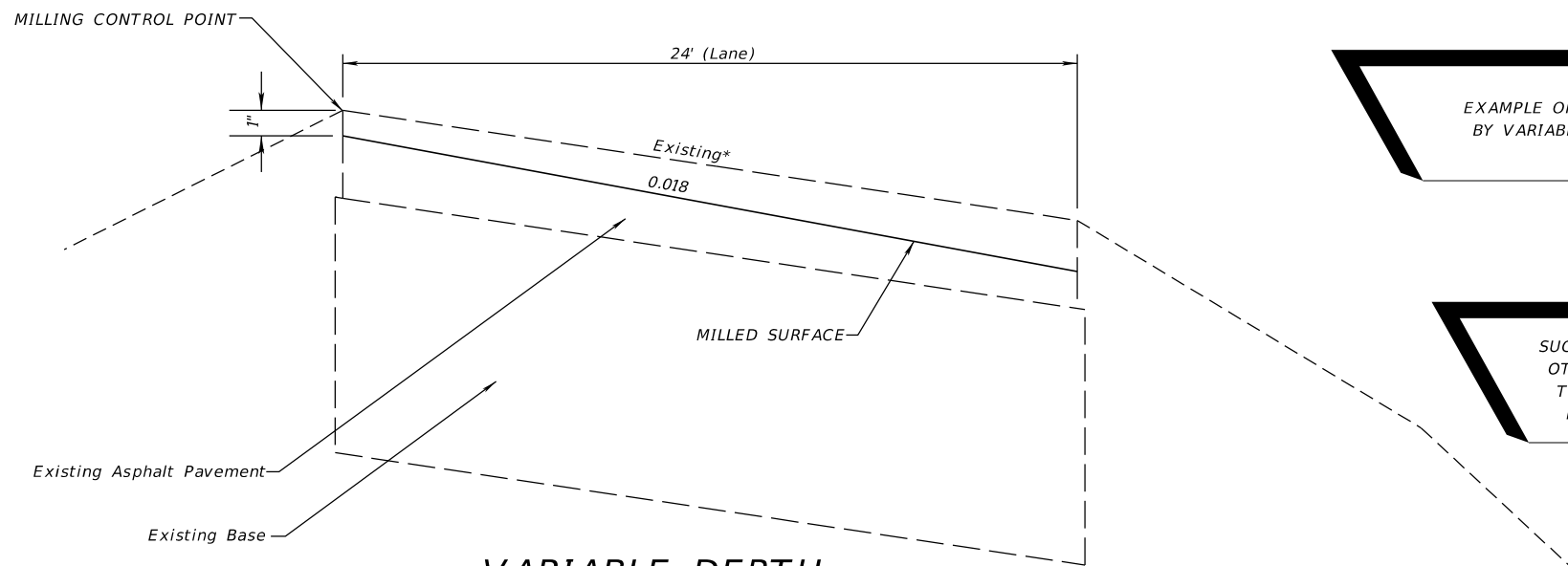

VARIABLE DEPTH MILLING DETAIL

EXAMPLE OF CROSS SLOPE CORRECTION BY VARIABLE MILLING AND OVERBUILD.

WHEN CROSS SLOPE CORRECTION IS NECESSARY SPECIAL MILLING, OVERBUILD AND LAYERING DETAILS MUST BE PROVIDED TO SUPPLEMENT TYPICAL SECTION. THE NEED FOR AND LOCATION OF PROFILE GRADES POINTS WILL DEPEND ON SITE SPECIFIC CONDITIONS.

SUGGESTED CONSTRUCTION SEQUENCES SHOWN. OTHER SEQUENCES THAT MEET SPECIFICATIONS, THICKNESS AND CROSS SLOPE REQUIREMENTS MAY BE CONSIDERED BY THE ENGINEER.

FOR STANDARD TYPICAL SECTION NOTES REFER TO EXHIBIT 6-1, THIS CHAPTER.

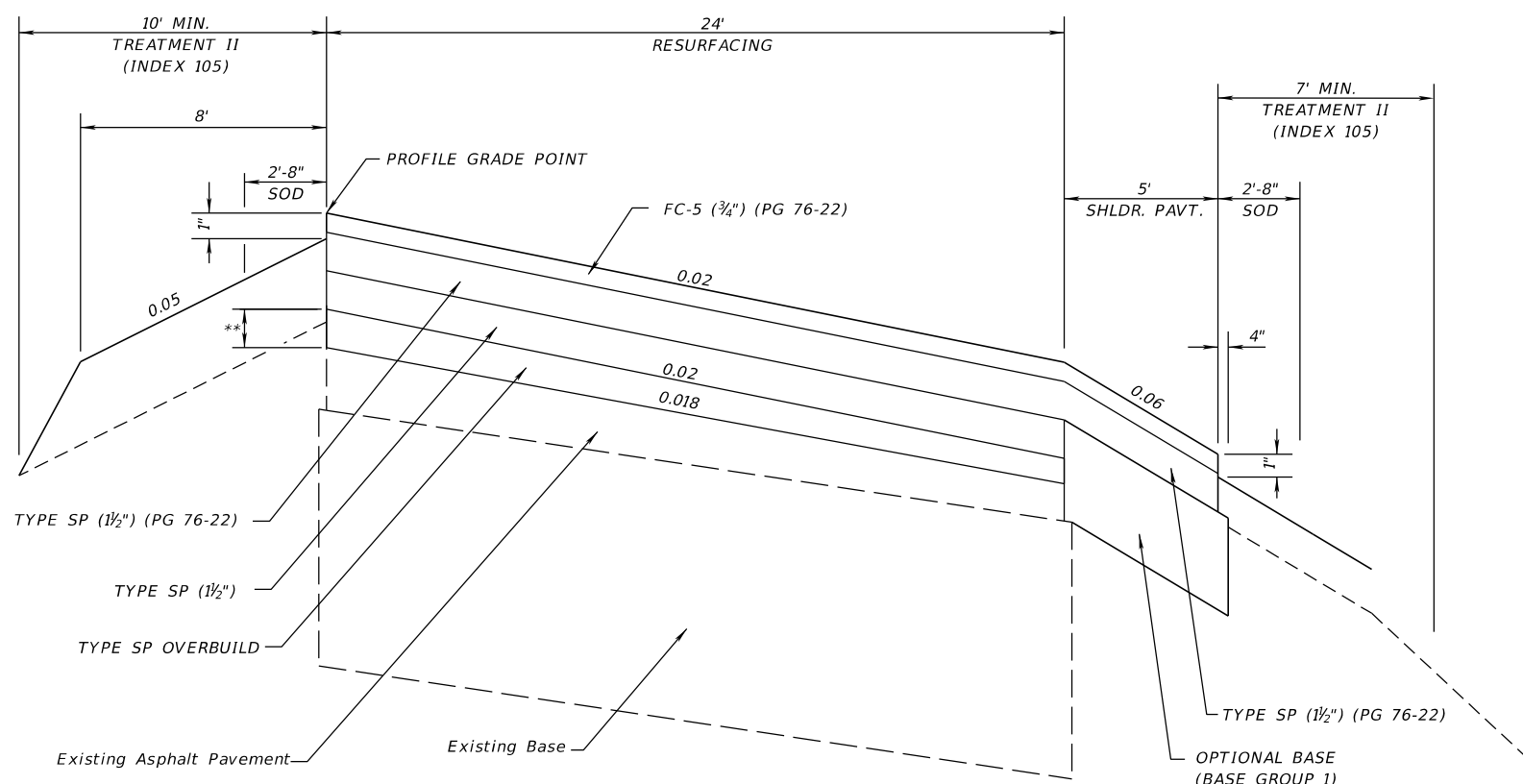

VARIABLE DEPTH OVERBUILD AND RESURFACING DETAIL

** TYPE SP OVERBUILD THICKNESSES (PER FDOT SPECIFICATION 334)

STA. 316+53.67 TO STA. 347+00.00

STATION	*EXISTING PAVEMENT CROSS SLOPES	
	EASTBOUND LANES INSIDE	EASTBOUND LANES OUTSIDE
317+00	0.014	0.013
318+00	0.012	0.012
319+00	0.013	0.013
320+00	0.011	0.012
321+00	0.013	0.014
322+00	0.013	0.015
323+00	0.014	0.015
324+00	0.013	0.013
325+00	0.012	0.012
326+00	0.012	0.011
327+00	0.013	0.011
328+00	0.014	0.012
329+00	0.015	0.013
330+00	0.015	0.013
331+00	0.014	0.014
332+00	0.013	0.016

STATION	*EXISTING PAVEMENT CROSS SLOPES	
	EASTBOUND LANES INSIDE	EASTBOUND LANES OUTSIDE
333+00	0.012	0.015
334+00	0.013	0.014
335+00	0.013	0.013
336+00	0.014	0.012
337+00	0.016	0.015
338+00	0.015	0.015
339+00	0.012	0.014
340+00	0.013	0.013
341+00	0.014	0.013
342+00	0.016	0.014
343+00	0.013	0.014
344+00	0.013	0.012
345+00	0.014	0.013
346+00	0.016	0.015
347+00	0.016	0.016

EXHIBIT TYP-13A
Date: 1/1/17

SHEET 2 OF 4

REVISIONS				STATE OF FLORIDA DEPARTMENT OF TRANSPORTATION			TYPICAL SECTION DETAILS	SHEET NO.
DATE	DESCRIPTION	DATE	DESCRIPTION	ROAD NO.	COUNTY	FINANCIAL PROJECT ID		
				22	BAY	123456-1-52-01		

THE OFFICIAL RECORD OF THIS SHEET IS THE ELECTRONIC FILE DIGITALLY SIGNED AND SEALED UNDER RULE 61G15-23.004, F.A.C.

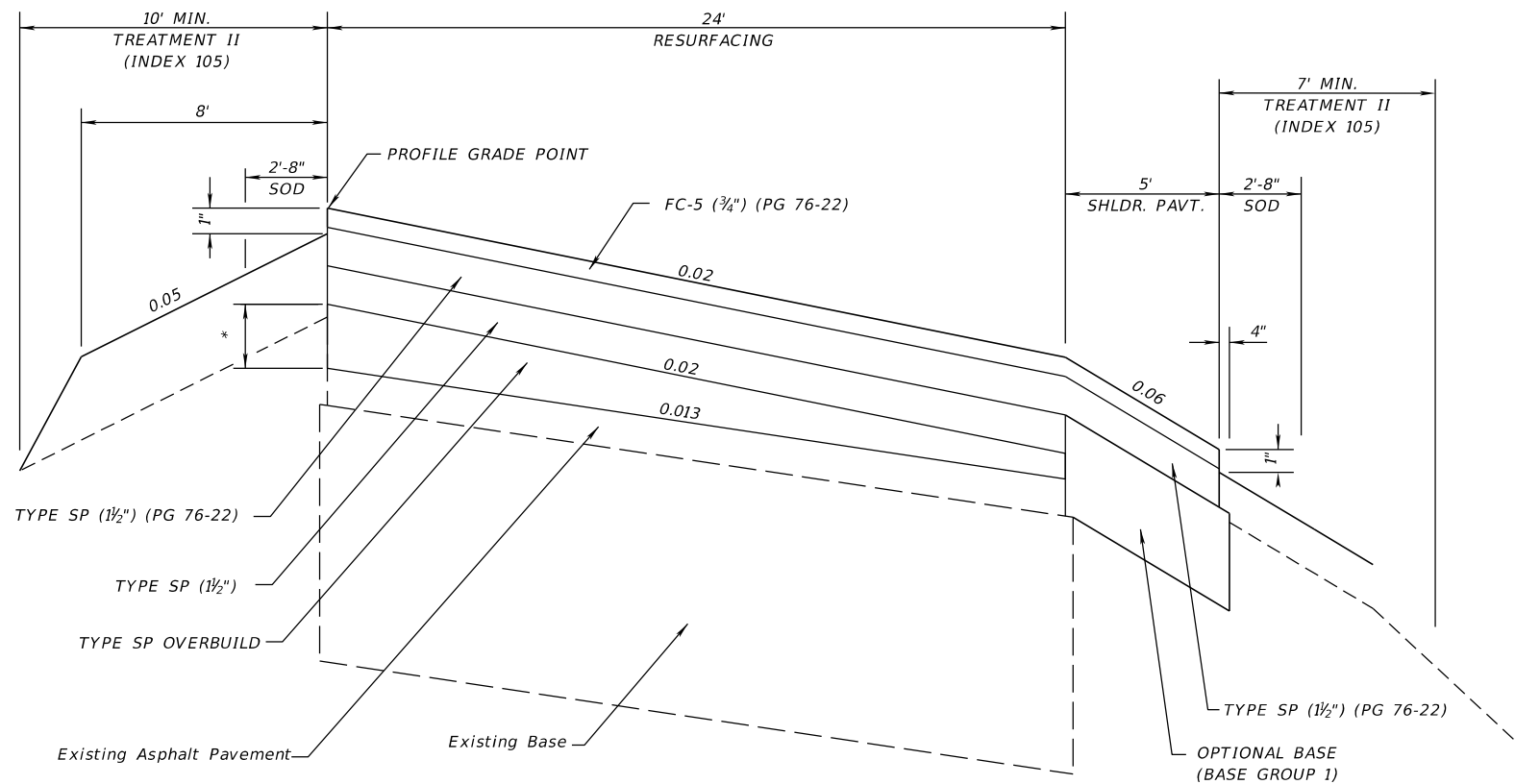

OVERBUILD AND RESURFACING DETAIL

* TYPE SP OVERBUILD THICKNESSES (PER FDOT SPECIFICATION 334)

EXAMPLE OF CROSS SLOPE CORRECTION BY CONSTANT DEPTH MILLING AND OVERBUILD.

WHEN CROSS SLOPE CORRECTION IS NECESSARY SPECIAL MILLING, OVERBUILD AND LAYERING DETAILS MUST BE PROVIDED TO SUPPLEMENT TYPICAL SECTION. THE NEED FOR AND LOCATION OF PROFILE GRADE POINTS WILL DEPEND ON SITE SPECIFIC CONDITIONS.

FOR STANDARD TYPICAL SECTION NOTES REFER TO EXHIBIT 6-1, THIS CHAPTER.

SUGGESTED CONSTRUCTION SEQUENCES SHOWN. OTHER SEQUENCES THAT MEET SPECIFICATIONS, THICKNESS AND CROSS SLOPE REQUIREMENTS MAY BE CONSIDERED BY THE ENGINEER.

STA. 600+10.00 TO STA. 620+00.00

EXISTING PAVEMENT CROSS SLOPES		
STATION	EASTBOUND LANES	
	INSIDE	OUTSIDE
600+00	0.015	0.015
601+00	0.014	0.014
602+00	0.013	0.013
603+00	0.013	0.012
604+00	0.013	0.013
605+00	0.013	0.015
606+00	0.012	0.015
607+00	0.012	0.015
608+00	0.013	0.014
609+00	0.012	0.013
610+00	0.013	0.011

EXISTING PAVEMENT CROSS SLOPES		
STATION	EASTBOUND LANES	
	INSIDE	OUTSIDE
611+00	0.014	0.011
612+00	0.015	0.012
613+00	0.015	0.013
614+00	0.014	0.014
615+00	0.013	0.016
616+00	0.012	0.015
617+00	0.013	0.014
618+00	0.013	0.013
619+00	0.014	0.013
620+00	0.016	0.016

EXHIBIT TYP-13B
Date: 1/1/14
SHEET 3 OF 4

REVISIONS				STATE OF FLORIDA DEPARTMENT OF TRANSPORTATION			TYPICAL SECTION DETAILS	SHEET NO.
DATE	DESCRIPTION	DATE	DESCRIPTION	ROAD NO.	COUNTY	FINANCIAL PROJECT ID		
				22	BAY	123456-1-52-01		

THE OFFICIAL RECORD OF THIS SHEET IS THE ELECTRONIC FILE DIGITALLY SIGNED AND SEALED UNDER RULE 61G15-23.004, F.A.C.

EXISTING PAVEMENT SUPERELEVATION				
STATION	WESTBOUND LANES		EASTBOUND LANES	
	INSIDE	OUTSIDE	INSIDE	OUTSIDE
400+10	0.018	0.020	0.015	0.018
P.C. STA 400+60	0.023	0.024	0.025	0.026
401+10	0.036	0.038	0.038	0.040
404+00	0.035	0.036	0.036	0.041
407+00	0.036	0.034	0.036	0.039
409+50	0.033	0.034	0.034	0.036
P.T. STA. 412+00	0.024	0.023	0.026	0.024
STA 412+50	0.021	0.020	0.018	0.021

THIS TABLE CAN BE USED TO TABULATE EXISTING PAVEMENT SUPERELEVATION IN THE PLANS FOR AREAS NEEDING SUPERELEVATION CORRECTION.

EXISTING PAVEMENT SUPERELEVATION				
STATION	WESTBOUND LANES		EASTBOUND LANES	
	INSIDE	OUTSIDE	INSIDE	OUTSIDE
699+50	0.015	0.018	0.018	0.019
PC STA 700+00	0.018	0.021	0.022	0.023
700+50	0.031	0.032	0.033	0.038
704+00	0.032	0.034	0.032	0.031
707+00	0.033	0.036	0.029	0.033
709+50	0.030	0.031	0.030	0.033
PT STA 710+00	0.020	0.021	0.023	0.021
STA 710+50	0.017	0.018	0.020	0.019

WHEN CROSS SLOPE CORRECTION IS NECESSARY SPECIAL MILLING AND LAYERING DETAILS MUST BE PROVIDED TO SUPPLEMENT TYPICAL SECTION. THE NEED FOR AND LOCATION OF PROFILE GRADE POINTS WILL DEPEND ON SITE SPECIFIC CONDITIONS.

FOR OTHER STANDARD TYPICAL SECTION NOTES REFER TO EXHIBIT 6-1, THIS CHAPTER.

EXHIBIT TYP-13C
Date: 1/1/13

SHEET 4 OF 4

REVISIONS				STATE OF FLORIDA DEPARTMENT OF TRANSPORTATION			TYPICAL SECTION DETAILS	SHEET NO.
DATE	DESCRIPTION	DATE	DESCRIPTION	ROAD NO.	COUNTY	FINANCIAL PROJECT ID		
				22	BAY	123456-1-52-01		

THE OFFICIAL RECORD OF THIS SHEET IS THE ELECTRONIC FILE DIGITALLY SIGNED AND SEALED UNDER RULE 61G15-23.004, F.A.C.

* \overline{B} SURVEY AND/OR
 \overline{C} CONSTRUCTION, AS APPLICABLE.

6-LANE
 ARTERIAL
 MILLING AND RESURFACING
 DIVIDED
 URBAN
 WITH BIKE LANES
 DESIGN SPEED 45 MPH OR LESS

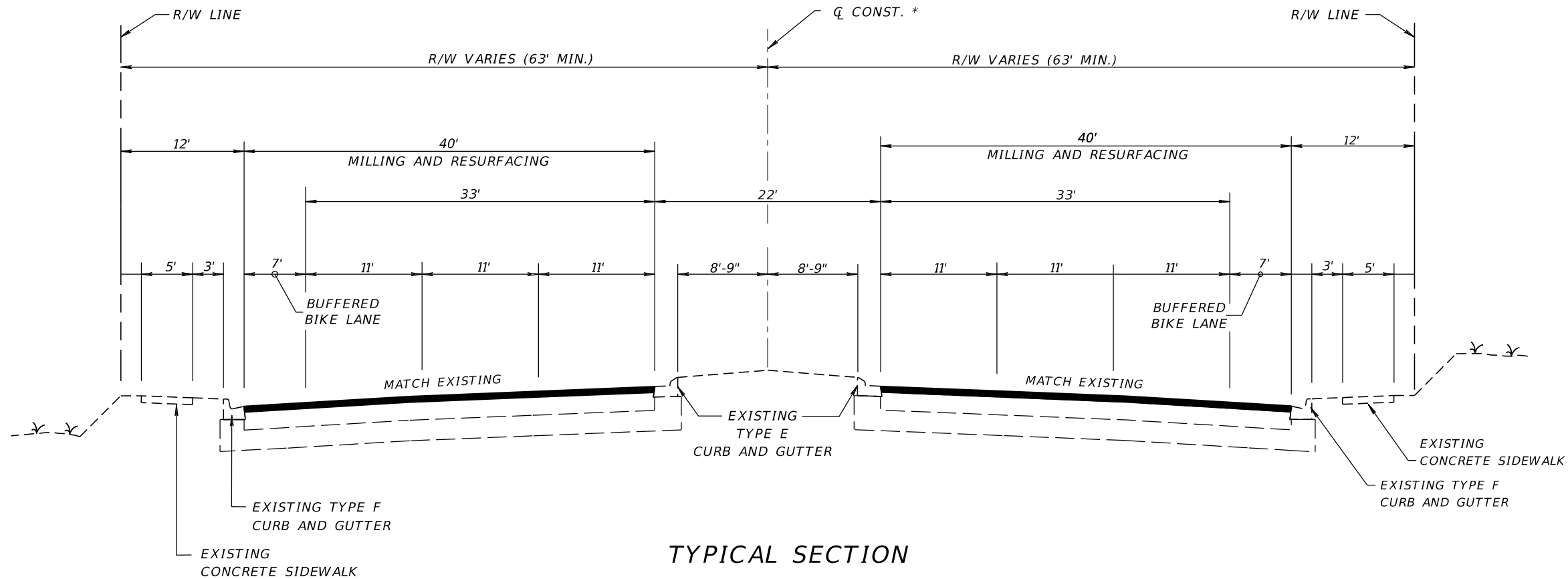

**TYPICAL SECTION
 SR 00 (JACKSON STREET)**

CONSTANT DEPTH MILLING AND RESURFACING
 STA. 101+21.00 TO STA. 221+44.00

MILLING

MILL EXISTING ASPHALT PAVEMENT (1 1/2" AVG. DEPTH)

RESURFACING

FRICITION COURSE FC-12.5 (TRAFFIC C) (1 1/2") (PG 76-22)

TRAFFIC DATA

CURRENT YEAR = 1998 AADT = 22800
 ESTIMATED OPENING YEAR = 2000 AADT = 25800
 ESTIMATED DESIGN YEAR = 2020 AADT = 30600
 K = 6% D = 55% T = 2% (24 HOUR)
 DESIGN HOUR T = 1%
 DESIGN SPEED = 45 MPH

TRAFFIC DATA IS REQUIRED TO BE
 NOTED FOR CURRENT YEAR, OPENING
 YEAR AND DESIGN YEAR.

FOR STANDARD TYPICAL SECTION NOTES
 REFER TO EXHIBIT 6-1, THIS CHAPTER.

EXHIBIT TYP-14
 Date: 1/1/15

REVISIONS				STATE OF FLORIDA DEPARTMENT OF TRANSPORTATION			SHEET NO.
DATE	DESCRIPTION	DATE	DESCRIPTION	ROAD NO.	COUNTY	FINANCIAL PROJECT ID	
				22	BAY	123456-5-20-1	TYPICAL SECTION

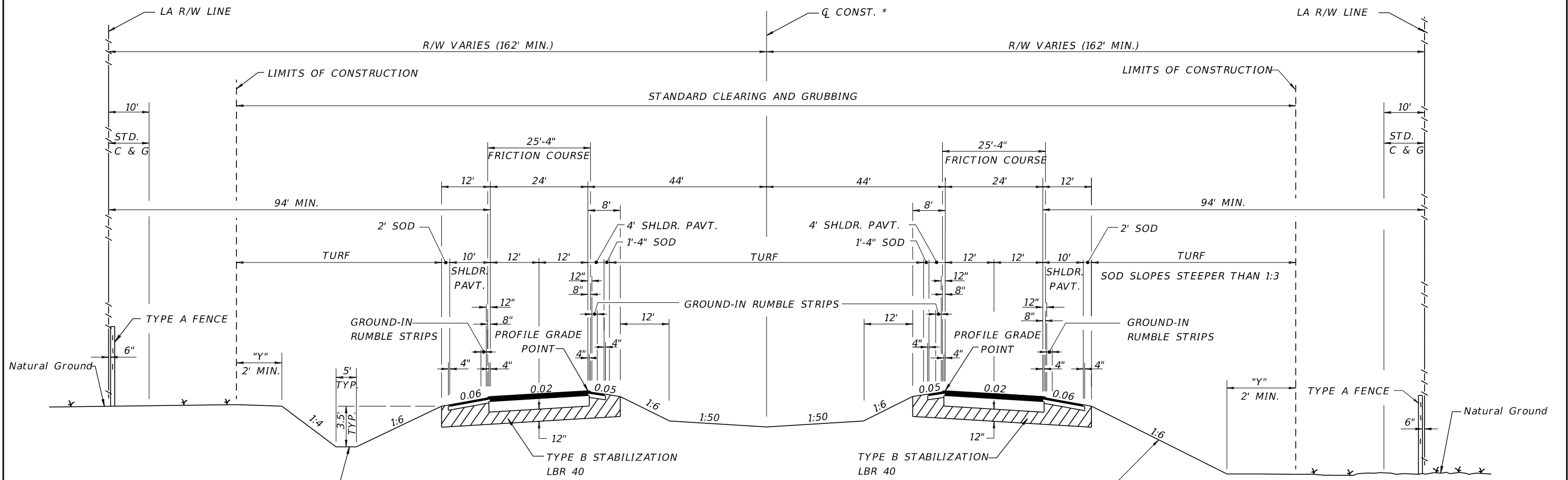

DEPTH AND WIDTH VARY
SEE CROSS SECTIONS

1:6 FOR FILLS TO 5'
1:6 TO EDGE OF CLEAR ZONE & 1:4 FOR FILLS 5' TO 10'
1:6 TO EDGE OF CLEAR ZONE & 1:3 FOR FILLS 10' TO 20'
1:2 (WITH GUARDRAIL) FILLS OVER 20'

TRAFFIC DATA

CURRENT YEAR = 1998 AADT = 22300
ESTIMATED OPENING YEAR = 2000 AADT = 23300
ESTIMATED DESIGN YEAR = 2020 AADT = 51500
K = 9 % D = 56 % T = 10 % (24 HOUR)
DESIGN HOUR T = 5 %
DESIGN SPEED = 70 MPH

TRAFFIC DATA IS REQUIRED TO BE NOTED FOR
CURRENT YEAR, OPENING YEAR, AND DESIGN YEAR.
POSTED SPEED (MPH) IS OPTIONAL.

FOR STANDARD TYPICAL SECTION NOTES
REFER TO EXHIBIT 6-1, THIS CHAPTER

**TYPICAL SECTION
SR 8
STA. 567+25.67 TO STA. 1056+84.35**

NEW CONSTRUCTION

OPTIONAL BASE GROUP 9 WITH
TYPE SP STRUCTURAL COURSE (TRAFFIC D) (2 1/2")
TYPE SP STRUCTURAL COURSE (TRAFFIC D) (1 1/2") (PG 76-22) AND
FRICITION COURSE FC-5 (3/4") (PG 76-22)

MEDIAN SHOULDER PAVEMENT

OPTIONAL BASE GROUP 1 WITH
TYPE SP STRUCTURAL COURSE (TRAFFIC D) (1 1/2")
TYPE SP STRUCTURAL COURSE (TRAFFIC D) (1 1/2") (PG 76-22) AND
FRICITION COURSE FC-5 (3/4") (PG 76-22)

OUTSIDE SHOULDER PAVEMENT

OPTIONAL BASE GROUP 1 WITH
TYPE SP STRUCTURAL COURSE (TRAFFIC B) (1 1/2") AND
FRICITION COURSE FC-5 (3/4") (PG 76-22)

NOTE:
HEIGHT OF FILL IS THE VERTICAL DISTANCE
FROM THE EDGE OF THE OUTSIDE TRAVEL LANE
TO TOE OF FRONT SLOPE.

* \bar{Q} SURVEY AND/OR
 \bar{Q} CONSTRUCTION, AS APPLICABLE.

4 LANE
INTERSTATE SYSTEM
NEW CONSTRUCTION
DIVIDED
RURAL
WITH PROJECTED
20 YR. AADT OF 1500
OR GREATER
DESIGN SPEED
70 MPH

"Y" THE AREA DISTURBED BY
CONSTRUCTION VARIES.

EXHIBIT TYP-15
Date: 1/1/15

REVISIONS				STATE OF FLORIDA DEPARTMENT OF TRANSPORTATION			SHEET NO.
DATE	DESCRIPTION	DATE	DESCRIPTION	ROAD NO.	COUNTY	FINANCIAL PROJECT ID	
				22	BAY	123456-1-52-01	

TYPICAL SECTION

THE OFFICIAL RECORD OF THIS SHEET IS THE ELECTRONIC FILE DIGITALLY SIGNED AND SEALED UNDER RULE 61G15-23.004, F.A.C.

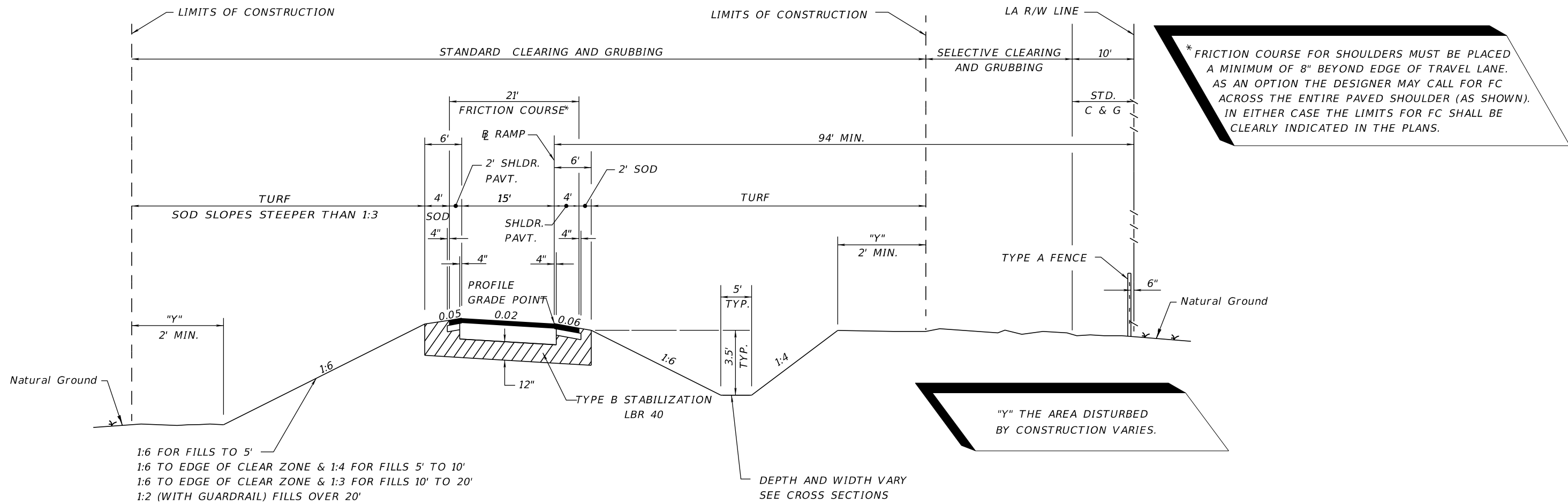

NOTE:
HEIGHT OF FILL IS THE VERTICAL DISTANCE FROM THE EDGE OF THE OUTSIDE TRAVEL LANE TO TOE OF FRONT SLOPE.

**TYPICAL SECTION
RAMP "B"**
STA. 415+67.28 TO STA. 421+23.68
(SINGLE LANE RAMP)

NEW CONSTRUCTION

OPTIONAL BASE GROUP 9 WITH
TYPE SP STRUCTURAL COURSE (TRAFFIC D) (2 1/2") (PG 76-22) AND
FRICTION COURSE FC-5 (3/4") (PG 76-22)

SHOULDER PAVEMENT

OPTIONAL BASE GROUP 1 WITH
TYPE SP STRUCTURAL COURSE (TRAFFIC D) (2 1/2") (PG 76-22) AND
FRICTION COURSE FC-5 (3/4") (PG 76-22)

FOR STANDARD TYPICAL SECTION NOTES REFER TO EXHIBIT 6-1, THIS CHAPTER.

EXHIBIT TYP-16
Date: 1/1/15

REVISIONS				STATE OF FLORIDA DEPARTMENT OF TRANSPORTATION			RAMP TYPICAL SECTION	SHEET NO.
DATE	DESCRIPTION	DATE	DESCRIPTION	ROAD NO.	COUNTY	FINANCIAL PROJECT ID		
				22	BAY	123456-1-52-01		

THE OFFICIAL RECORD OF THIS SHEET IS THE ELECTRONIC FILE DIGITALLY SIGNED AND SEALED UNDER RULE 61G15-23.004, F.A.C.

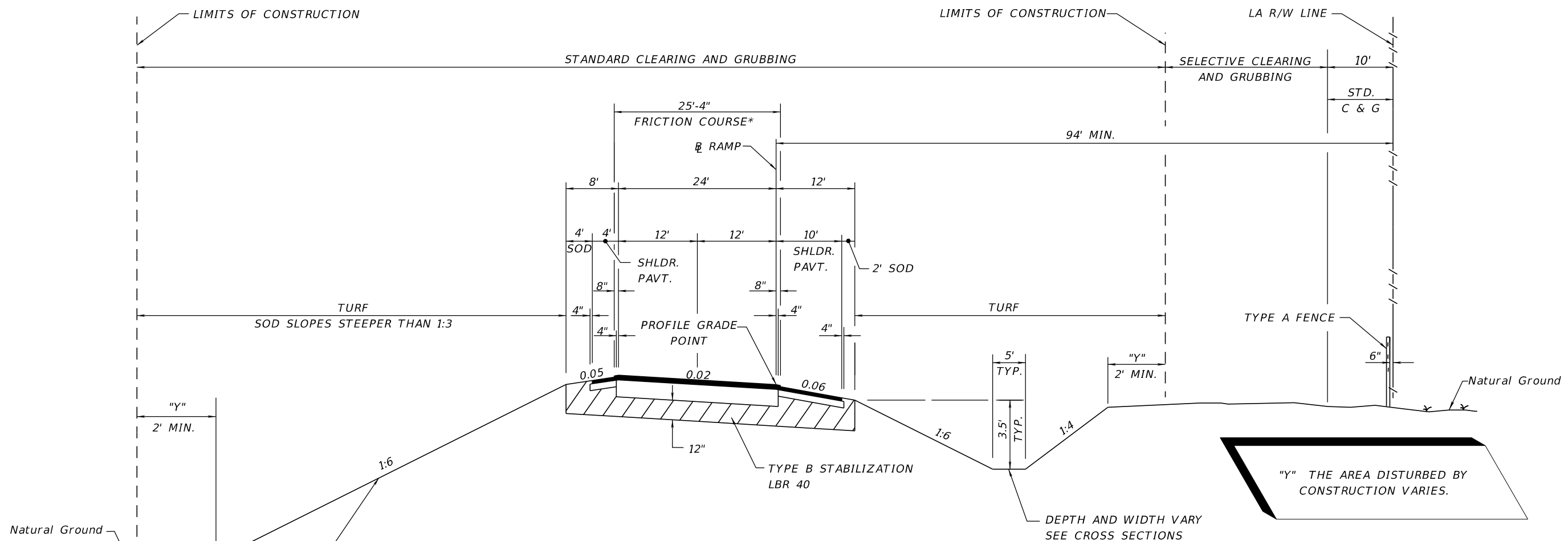

**TYPICAL SECTION
RAMP "C"
STA. 623+28.64 TO STA. 629+13.78
(TWO LANE RAMP)**

NEW CONSTRUCTION

OPTIONAL BASE GROUP 9 WITH
TYPE SP STRUCTURAL COURSE (TRAFFIC D) (2") (PG 76-22) AND
FRICION COURSE FC-5 (3/4") (PG 76-22)

LEFT SHOULDER PAVEMENT

OPTIONAL BASE GROUP 1 WITH
TYPE SP STRUCTURAL COURSE (TRAFFIC D) (2") (PG 76-22) AND
FRICION COURSE FC-5 (3/4") (PG 76-22)

RIGHT SHOULDER PAVEMENT

OPTIONAL BASE GROUP 1 WITH
TYPE SP STRUCTURAL COURSE (TRAFFIC B) (2") AND
FRICION COURSE FC-5 (3/4") (PG 76-22)

* FRICTION COURSE FOR SHOULDERS MUST BE PLACED A MINIMUM OF 8" BEYOND EDGE OF TRAVEL LANE. AS AN OPTION THE DESIGNER MAY CALL FOR FC ACROSS THE ENTIRE PAVED SHOULDER. IN EITHER CASE THE LIMITS FOR FC SHALL BE CLEARLY INDICATED IN THE PLANS.

FOR STANDARD TYPICAL SECTION NOTES REFER TO EXHIBIT 6-1, THIS CHAPTER

1:6 FOR FILLS TO 5'
1:6 TO EDGE OF CLEAR ZONE & 1:4 FOR FILLS 5' TO 10'
1:6 TO EDGE OF CLEAR ZONE & 1:3 FOR FILLS 10' TO 20'
1:2 (WITH GUARDRAIL) FILLS OVER 20'

NOTE:
HEIGHT OF FILL IS THE VERTICAL DISTANCE FROM THE EDGE OF THE OUTSIDE TRAVEL LANE TO TOE OF FRONT SLOPE.

EXHIBIT TYP-17
Date: 1/1/17

REVISIONS				STATE OF FLORIDA DEPARTMENT OF TRANSPORTATION	SHEET NO.
DATE	DESCRIPTION	DATE	DESCRIPTION		
				22 BAY 123456-1-52-01	

THE OFFICIAL RECORD OF THIS SHEET IS THE ELECTRONIC FILE DIGITALLY SIGNED AND SEALED UNDER RULE 61G15-23.004, F.A.C.

** \overline{B} SURVEY AND/OR
 \overline{C} CONSTRUCTION, AS APPLICABLE.

IF LANDSCAPING IS DESIRED, TREES SHALL BE
 TYPES THAT WILL NOT HAVE AN EXPECTED
 GROWTH GREATER THAN 4" IN DIAMETER
 MEASURED 6" ABOVE THE GROUND.

TURF SLOPES 1:3 OR FLATTER
 * SOD SLOPES STEEPER THAN 1:3

4-LANE
 ARTERIAL
 NEW CONSTRUCTION
 DIVIDED
 URBAN AND SUBURBAN
 WITH BIKE LANES
 DESIGN SPEED 50-55 MPH

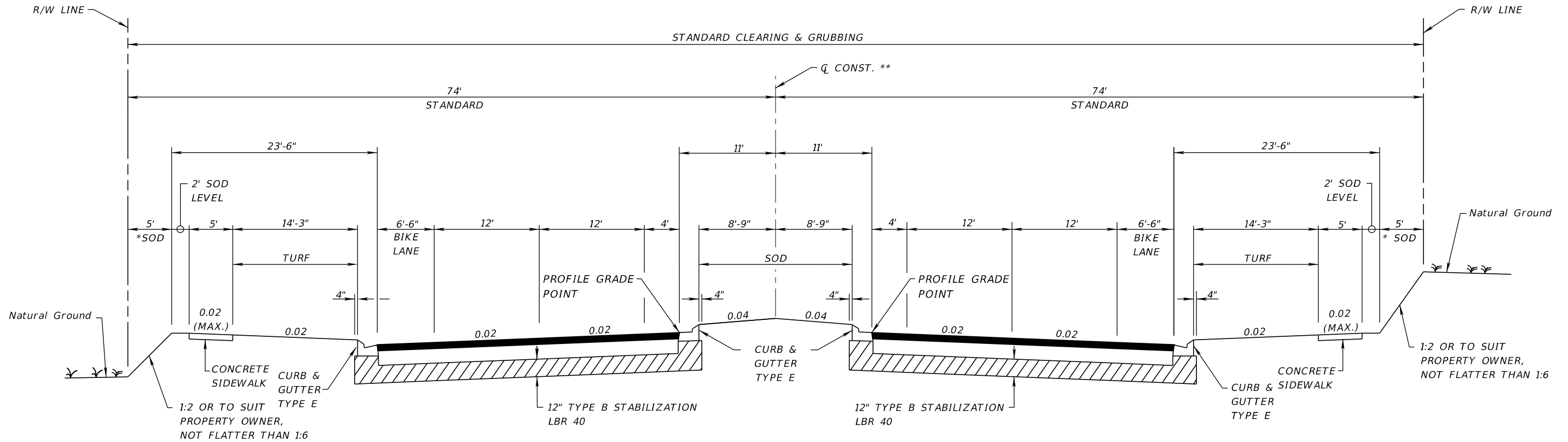

TRAFFIC DATA

CURRENT YEAR = 1999 AADT = 22800
 ESTIMATED OPENING YEAR = 2002 AADT = 25800
 ESTIMATED DESIGN YEAR = 2022 AADT = 30600
 K = 6% D = 55% T = 2% (24 HOUR)
 DESIGN HOUR T = 1%
 DESIGN SPEED = 55 MPH

TRAFFIC DATA IS REQUIRED TO BE
 NOTED FOR CURRENT YEAR, OPENING
 YEAR AND DESIGN YEAR.
 POSTED SPEED (MPH) IS OPTIONAL.

FOR STANDARD TYPICAL SECTION NOTES
 REFER TO EXHIBIT 6-1, THIS CHAPTER.

**TYPICAL SECTION
 SR 00 (SARA AVE.)
 STA. 50+40.00 TO STA. 125+50.00**

NEW CONSTRUCTION

OPTIONAL BASE GROUP 9 WITH
 TYPE SP STRUCTURAL COURSE (TRAFFIC C) (3 1/2")
 AND FRICTION COURSE FC-5 (3/4") (PG 76-22)

EXHIBIT TYP-18
 Date: 1/1/17

REVISIONS				STATE OF FLORIDA DEPARTMENT OF TRANSPORTATION			SHEET NO.
DATE	DESCRIPTION	DATE	DESCRIPTION	ROAD NO.	COUNTY	FINANCIAL PROJECT ID	
				22	BAY	123456-1-52-01	

TYPICAL SECTION

THE OFFICIAL RECORD OF THIS SHEET IS THE ELECTRONIC FILE DIGITALLY SIGNED AND SEALED UNDER RULE 61G15-23.004, F.A.C.

** \square SURVEY AND/OR
 \square CONSTRUCTION, AS APPLICABLE.

4-LANE
 ARTERIAL
 NEW CONSTRUCTION
 DIVIDED
 SUBURBAN
 WITH BIKE LANES
 DESIGN SPEED 50-55 MPH

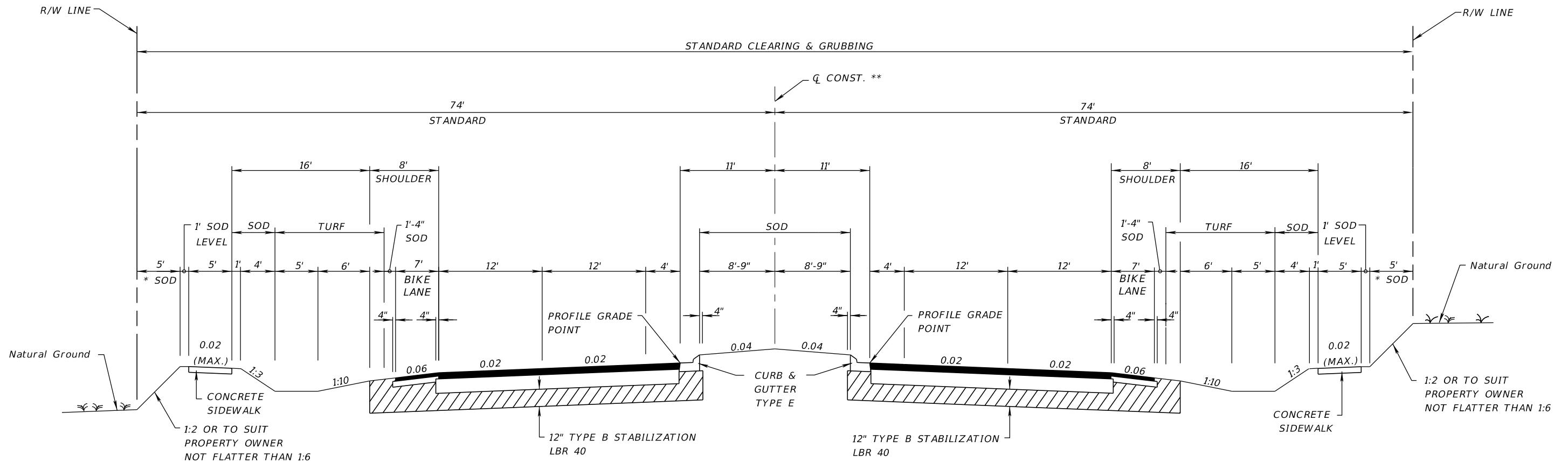

TRAFFIC DATA

CURRENT YEAR = 1999 AADT = 22800
 ESTIMATED OPENING YEAR = 2002 AADT = 25800
 ESTIMATED DESIGN YEAR = 2022 AADT = 30600
 K = 6% D = 55% T = 2% (24 HOUR)
 DESIGN HOUR T = 1%
 DESIGN SPEED = 55 MPH

TRAFFIC DATA IS REQUIRED TO BE
 NOTED FOR CURRENT YEAR, OPENING
 YEAR AND DESIGN YEAR.
 POSTED SPEED (MPH) IS OPTIONAL.

FOR STANDARD TYPICAL SECTION NOTES
 REFER TO EXHIBIT 6-1, THIS CHAPTER.

**TYPICAL SECTION
 SR 00 (CODY ROAD)
 STA. 100+40.00 TO STA. 225+50.00**

NEW CONSTRUCTION

OPTIONAL BASE GROUP 9 WITH
 TYPE SP STRUCTURAL COURSE (TRAFFIC C) (3 1/2")
 AND FRICTION COURSE FC-5 (3/4") (PG 76-22)

SHOULDER PAVEMENT

OPTIONAL BASE GROUP 1 WITH
 TYPE SP STRUCTURAL COURSE (TRAFFIC C) (1 1/2")
 AND FRICTION COURSE FC-5 (3/4") (PG 76-22)

TURF SLOPES 1:3 OR FLATTER
 * SOD SLOPES STEEPER THAN 1:3

IF LANDSCAPING IS DESIRED, TREES SHALL BE
 TYPES THAT WILL NOT HAVE AN EXPECTED
 GROWTH GREATER THAN 4" IN DIAMETER
 MEASURED 6" ABOVE THE GROUND.

EXHIBIT TYP-19
 Date: 1/1/17

REVISIONS				STATE OF FLORIDA DEPARTMENT OF TRANSPORTATION			SHEET NO.
DATE	DESCRIPTION	DATE	DESCRIPTION	ROAD NO.	COUNTY	FINANCIAL PROJECT ID	
				22	BAY	123456-1-52-01	

TYPICAL SECTION

THE OFFICIAL RECORD OF THIS SHEET IS THE ELECTRONIC FILE DIGITALLY SIGNED AND SEALED UNDER RULE 61G15-23.004, F.A.C.

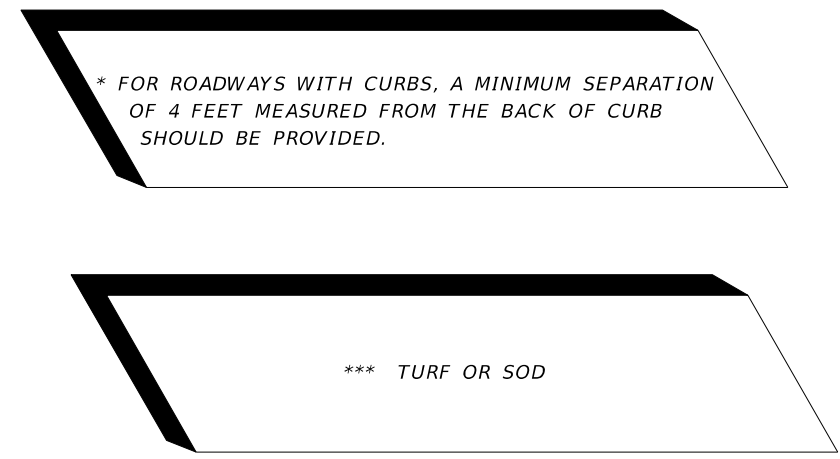
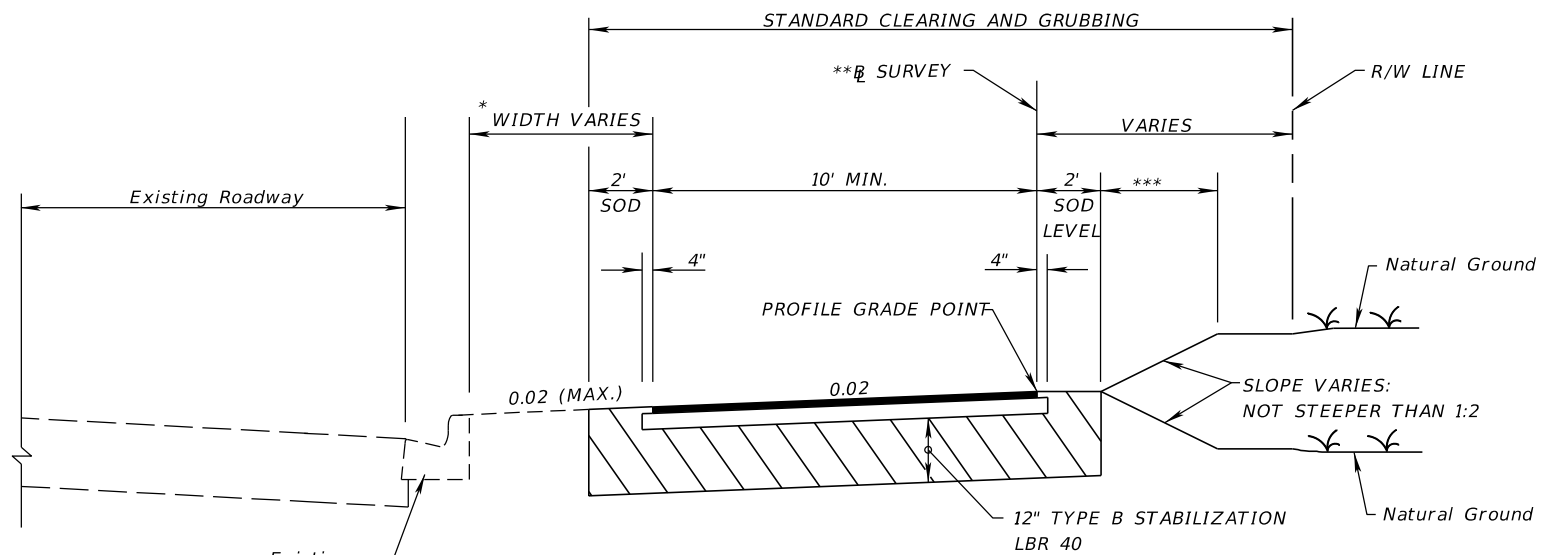

**TYPICAL SECTION
SHARED USE PATH
SR 00 (WILLOW WAY)
STA. 122+00.000 TO STA. 210+65.000**

PATH DESIGN SPEED = 18 MPH

PATH
OPTIONAL BASE GROUP 1 WITH
TYPE SP STRUCTURAL COURSE (TRAFFIC A) (1 1/2")

** \mathcal{Q} SURVEY AND/OR
 \mathcal{Q} CONSTRUCTION, AS APPLICABLE.

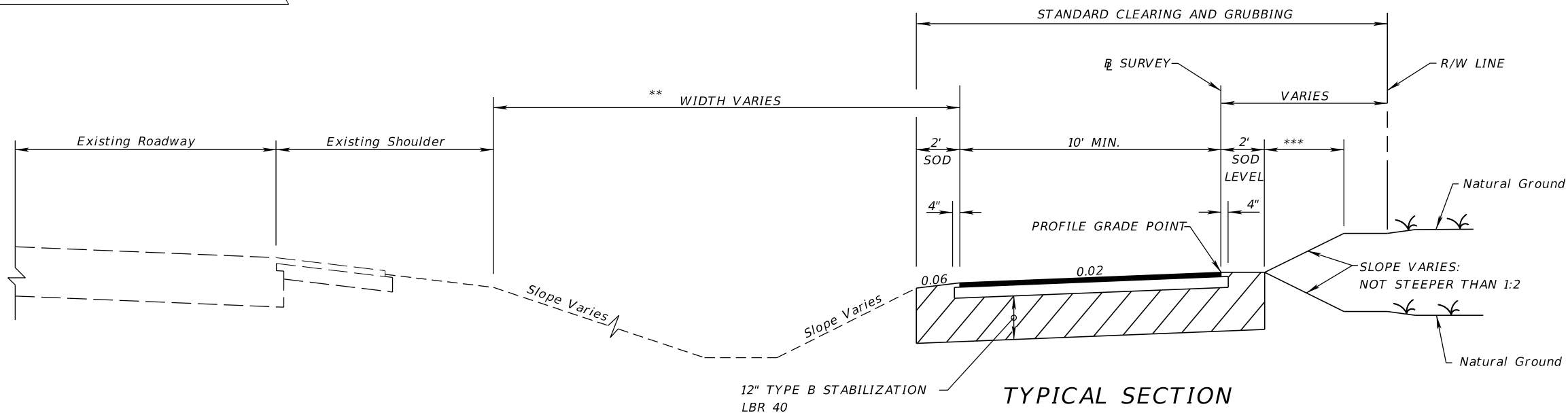

**TYPICAL SECTION
SHARED USE PATH
SR 00 (DEXTON HEIGHTS)
STA. 22+00.000 TO STA. 51+65.000**

PATH DESIGN SPEED = 18 MPH

PATH
OPTIONAL BASE GROUP 1 WITH
TYPE SP STRUCTURAL COURSE (TRAFFIC A) (1 1/2")

** FOR ROADWAYS WITH FLUSH SHOULDERS, A
MINIMUM SEPARATION OF 5 FEET MEASURED FROM
THE OUTSIDE EDGE OF SHOULDER TO THE INSIDE
EDGE OF THE SHARED USE PATH SHOULD BE
PROVIDED.

EXHIBIT TYP-20
Date: 1/1/17

REVISIONS				STATE OF FLORIDA DEPARTMENT OF TRANSPORTATION	ROAD NO.	COUNTY	FINANCIAL PROJECT ID	SHEET NO.
DATE	DESCRIPTION	DATE	DESCRIPTION					

*** \square SURVEY AND/OR
 \square CONSTRUCTION, AS APPLICABLE.

**** IF LIMITS OF CONSTRUCTION
 EXCEED RIGHT OF WAY, A
 PROPERTY AGREEMENT IS REQUIRED.

6-LANE
 ARTERIAL
 NEW CONSTRUCTION
 DIVIDED
 URBAN AND SUBURBAN
 WITH BIKE LANES
 DESIGN SPEED 50-55 MPH

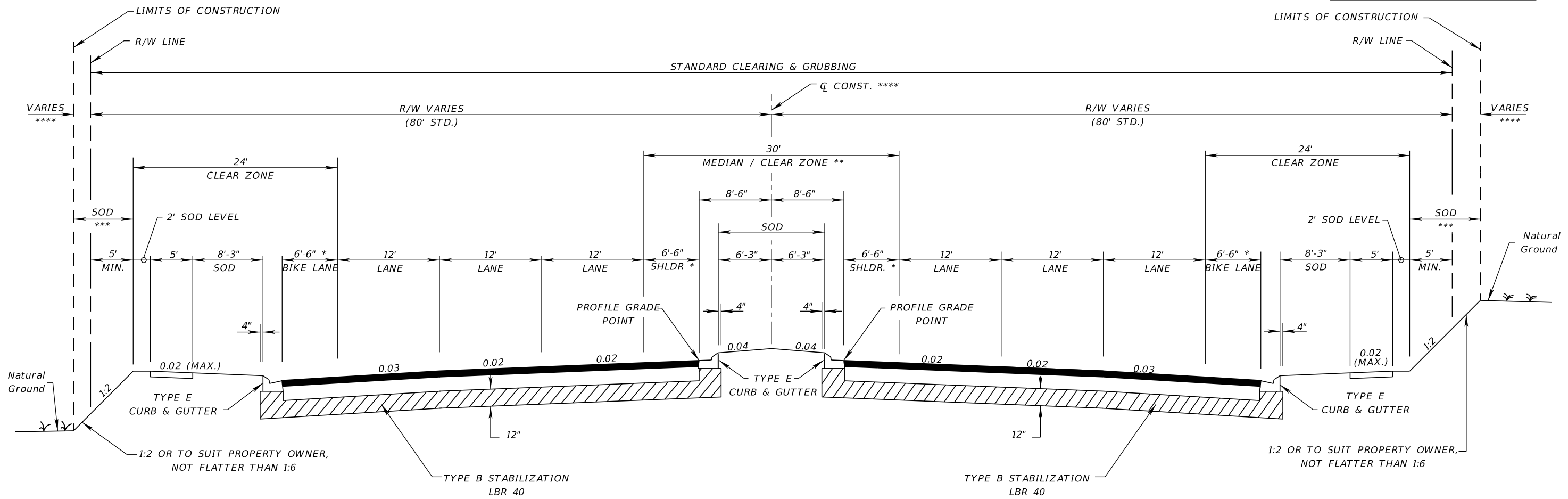

TYPICAL SECTION
SR 00 (SOUTH INDEPENDENCE STREET)
STA. 401+30.00 TO STA. 788+66.00

TRAFFIC DATA

CURRENT YEAR = 1998 AADT = 22800
 ESTIMATED OPENING YEAR = 2000 AADT = 25800
 ESTIMATED DESIGN YEAR = 2020 AADT = 30600
 K = 6% D = 55% T = 2% (24 HOUR)
 DESIGN HOUR T = 1%
 DESIGN SPEED = 50 MPH

TRAFFIC DATA IS REQUIRED TO BE
 NOTED FOR CURRENT YEAR, OPENING
 YEAR AND DESIGN YEAR.

FOR STANDARD TYPICAL SECTION NOTES
 REFER TO EXHIBIT 6-1, THIS CHAPTER.

NEW CONSTRUCTION
 OPTIONAL BASE GROUP 9 WITH
 TYPE SP STRUCTURAL COURSE (TRAFFIC C) (3 1/2")
 AND FRICTION COURSE FC-5 (3/4") (PG 76-22)

* PROVIDES FOR 8' OF USABLE SHOULDER

** THE 30' MEDIAN AREA PROVIDES SUFFICIENT WIDTH FOR:
 - 24' CLEAR ZONE
 - DUAL LEFT TURN LANES (11' lanes, 4' separator in median shoulder)
 - DIRECTIONAL MEDIAN OPENING (4' separators in median shoulder)

*** TURF OR SOD

EXHIBIT TYP-21
 Date: 1/1/17

REVISIONS				STATE OF FLORIDA DEPARTMENT OF TRANSPORTATION			SHEET NO.
DATE	DESCRIPTION	DATE	DESCRIPTION	ROAD NO.	COUNTY	FINANCIAL PROJECT ID	
				22	BAY	123456-7-15-20	

TYPICAL SECTION

THE OFFICIAL RECORD OF THIS SHEET IS THE ELECTRONIC FILE DIGITALLY SIGNED AND SEALED UNDER RULE 61G15-23.004, F.A.C.