

STATE OF FLORIDA DEPARTMENT OF TRANSPORTATION



DRAINAGE MANUAL

OFFICE OF DESIGN, DRAINAGE SECTION JANUARY 2016
TALLAHASSEE, FLORIDA

TABLE OF CONTENTS

Chapter 1 Introduction.....	4
1.1 Purpose.....	4
1.2 Authority.....	4
1.3 Scope.....	4
1.4 General	4
1.5 Documentation of Drainage Design	5
1.6 Appendices	5
1.7 Distribution	6
1.8 Procedure for Revisions and Updates.....	6
1.9 Training	6
1.10 Forms Access	6
Chapter 2 Open Channel	7
2.1 Introduction	7
2.2 Design Frequency	7
2.3 Hydrologic Analysis.....	7
2.4 Hydraulic Analysis.....	8
2.4.1 Manning's "n" Values	8
2.4.2 Slope.....	8
2.4.3 Channel Linings and Velocity.....	8
2.4.3.1 Limitations on Use of Linings	9
2.4.4 Channel Bottom	10
2.4.5 Channel Freeboard.....	10
2.5 Construction and Maintenance Considerations.....	10
2.6 Safety.....	11
2.6.1 Protective Treatment.....	11
2.6.2 Roadside Safety.....	11
2.7 Documentation.....	11
Chapter 3 Storm Drain Hydrology and Hydraulics.....	15
3.1 Introduction	15
3.2 Pipe Materials	15
3.3 Design Frequency	15
3.4 Design Tailwater	16
3.4.1 Sea Level Rise.....	17
3.5 Hydrologic Analysis.....	20
3.5.1 Time of Concentration.....	20
3.6 Hydraulic Analysis.....	20
3.6.1 Pipe Slopes.....	20
3.6.2 Hydraulic Gradient	20
3.6.3 Outlet Velocity.....	21

3.6.4	Manning's Roughness Coefficients	21
3.7	Hydraulic Openings and Protective Treatment.....	22
3.7.1	Entrance Location and Spacing	24
3.7.2	Manholes	25
3.7.3	Shoulder Gutter.....	25
3.7.4	Inlet Placement	26
3.8	Grades	30
3.8.1	Longitudinal Gutter Grade.....	30
3.9	Spread Standards	30
3.9.1	Spread for Permanent Construction.....	30
3.9.2	Spread for Temporary Construction.....	30
3.10	Construction and Maintenance Considerations.....	31
3.10.1	Pipe Size and Length.....	31
3.10.2	Minimum Clearances	32
3.10.3	Pipe Joint Designs Greater than 5 psi.....	33
3.11	Pipes within or Adjacent to Retained Earth (Walled) Embankment Sections	34
3.12	Additional Design Considerations	34
3.12.1	Noise Walls	34
3.12.2	French Drains	34
3.12.3	Resilient Connectors.....	35
3.13	Documentation	36
3.13.1	Tabulation Form.....	36
3.13.2	Other Documentation.....	36
Chapter 4	Cross Drain Hydraulics	38
4.1	Introduction	38
4.2	General	38
4.2.2	LRFD Design Code Bridge Design Specifications.....	39
4.3	Design Frequency	39
4.3.1	Permanent Facilities	39
4.3.2	Temporary Facilities.....	39
4.4	Backwater	40
4.5	Tailwater	40
4.6	Clearances.....	41
4.7	Hydrologic Analysis.....	41
4.7.1	Freshwater Flow	41
4.7.2	Tidal Flow	41
4.8	Hydraulic Analysis.....	42
4.8.1	Riverine Crossings.....	42
4.8.2	Tidal Crossings	42
4.9	Specific Standards Relating to Bridges	43
4.9.1	Berms for Spill-Through Abutment Bridges.....	43

4.9.2	Scour Estimates.....	43
4.9.3	Scour Protection Considerations.....	46
4.9.4	Bridge Deck Drainage.....	48
4.9.5	Wave and Current Forces on Coastal Bridges.....	48
4.10	Specific Standards relating to all Cross Drains except Bridges.....	49
4.10.1	Culvert Materials.....	49
4.10.2	Manning's Roughness Coefficients.....	49
4.10.3	End Treatment.....	50
4.10.4	Construction and Maintenance Considerations.....	50
4.11	Documentation.....	51
4.11.1	Culverts (all culverts less than a 20' bridge culvert).....	51
4.11.2	Bridges.....	52
4.11.3	Document Processing.....	55
Chapter 5	Stormwater Management.....	56
5.1	Introduction.....	56
5.2	Regulatory Requirements.....	56
5.2.1	Chapter 14-86, Florida Administrative Code.....	56
5.2.2	Section 373.4596, Florida Statutes.....	56
5.2.3	Chapter 62-25, Florida Administrative Code.....	56
5.2.4	Chapter 62-40, Florida Administrative Code.....	56
5.2.5	National Pollutant Discharge Elimination System.....	57
5.3	Environmental Look Arouds (ELA).....	57
5.4	Design Standards.....	58
5.4.1	Design of Systems.....	58
5.4.2	Hydrologic Methods.....	60
5.4.3	Protective Treatment.....	60
5.4.4	Construction and Maintenance Considerations.....	60
5.5	Documentation.....	63
Chapter 6	Optional Culvert Materials.....	65
6.1	Introduction.....	65
6.2	Durability.....	65
6.2.1	Culvert Service Life Estimation.....	66
6.3	Structural Evaluation.....	66
6.4	Hydraulic Evaluations.....	66
6.5	Culvert Material Types.....	67
6.6	Jack and Bore.....	68
6.7	Documentation.....	68
Appendix A	Drainage Law.....	71
Appendix B	Acquisition of Real Property Rights.....	87
Appendix C	Cover Height Tables.....	91
Appendix D	Pipes within Walled Embankment Sections.....	111

Chapter 1

Introduction

1.1 Purpose

The *Drainage Manual* sets forth drainage design standards for Florida Department of Transportation (FDOT) projects.

1.2 Authority

Chapter 334, *Florida Statute (F.S.)* Sections 20.23(4)(a) and 334.048(3), *Florida Statutes (F.S.)*

1.3 Scope

The principal users of this *Manual* are consultants and FDOT personnel who prepare FDOT construction plans.

1.4 General

Chapter 334, F.S., known as the **Florida Transportation Code**, establishes the responsibilities of the State, counties, and municipalities for the planning and development of the transportation systems serving the people of Florida, with the objective of assuring development of an integrated, balanced statewide system. The Code's purpose is to protect the safety and general welfare of the people of the State and to preserve and improve all transportation facilities in Florida. Under **Section 334.044, F.S.**, the **Code** sets forth the powers and duties of the Department of Transportation to develop and adopt uniform minimum standards and criteria for the design, construction, maintenance, and operation of public roads.

The standards in this *Manual* provide a basis for uniform design practice for typical roadway drainage design situations. Realizing that drainage design is primarily a matter of sound application of good engineering judgment, it is impossible to give precise rules which would apply to all possible situations that may arise. Situations will exist where these standards will not apply. THE INAPPROPRIATE USE OF AND/OR ADHERENCE TO THESE STANDARDS DOES NOT EXEMPT THE ENGINEER FROM THE PROFESSIONAL RESPONSIBILITY OF DEVELOPING AN APPROPRIATE DESIGN. The engineer is responsible for identifying those standards that do not apply to a particular design, and to obtain approval to deviate from those standards. Deviation from a standard in this *Manual* must be approved by the District Drainage Engineer. The request for

deviation shall include the engineering justification.

23 CFR 650A (<http://www.fhwa.dot.gov/legregs/directives/fapg/cfr0650a.htm>) prescribes the Federal Highway Administration (FHWA) policies and procedures for the location and hydraulic design of highway encroachments on flood plains. While the standards presented in the FDOT *Drainage Manual* conform to Federal requirements, drainage designers are advised to become familiar with **23 CFR 650A** to develop a basic understanding of some of the design standards for cross drains and bridges.

Statistical rainfall depth data for Florida is found in NOAA Atlas 14 Rainfall Data. This data is available at http://hdsc.nws.noaa.gov/hdsc/pfds/pfds_map_cont.html?bkmrk=fl. FDOT Rainfall distributions and intensity-duration-frequency curves may be found at <http://www.dot.state.fl.us/rddesign/Drainage/files/IDFCurves.pdf>.

1.5 Documentation of Drainage Design

Approvals of deviation from the Manual shall be included in the project drainage design documentation along with supporting justifications. The hydraulic designer shall provide the Department a signed and sealed Drainage Design Report that addresses the entire project design. It shall be a record set of all drainage computations, both hydrologic and hydraulic and shall include all necessary support data. The Drainage Design Report shall include, at a minimum, pond routing calculations in ICPR or equivalent software, with justifications of all tailwater stages utilized, a clear description of the overall stormwater management system, storm drain tabulations in Department format, pond recovery calculations, hydraulic spread calculations, special gutter grade calculations, drainage structure and liner flotation calculations, ditch conveyance calculations, a node-reach diagram superimposed on Department drainage maps, skimmer calculations, cross drain calculations and other calculations relative to drainage.

Modification for Non-conventional Projects:

The hydraulic designer shall provide the Department a Drainage Design Report to accompany all phase submittals (which shall be signed and sealed at the Final Phase submittal) that addresses the entire project design.

1.6 Appendices

Included with this *Manual* are four appendices:

Appendix A contains a general overview of drainage law with discussion of case histories in Florida. It is provided as an appendix rather than a chapter since it is primarily informational and does not constitute a standard.

Appendix B contains guidance on general FDOT practice with regard to acquisition of drainage easements, flood rights, etc.

Appendix C contains minimum and maximum cover heights for design.

Appendix D contains policy on the selection of pipes in proximity to structural walls.

1.7 Distribution

This **Manual** is available for downloading from the website below:

<http://www.dot.state.fl.us/rddesign/Drainage/files/DrainageManual.pdf>

1.8 Procedure for Revisions and Updates

Comments and suggestions for changes to the **Manual** are invited to be submitted by e-mailing the [State Drainage Engineer](#). Appropriate Roadway Design or Drainage Design staff will review each idea or suggestion received in a timely manner.

Statewide meetings of the District Drainage Engineers and the State Drainage Engineer are held at least annually and teleconferences are held monthly. A major agenda item at these meetings will be the review of planned revisions, and suggestions and comments that may warrant revisions. Based on input from these meetings, official proposed revisions are developed.

The State Drainage Engineer will coordinate the proposed revisions with all the affected offices and with FHWA. Official adoption of the proposed revisions is made by State Drainage Engineer with input from the District Drainage Engineers.

Prior to release, all revisions will be coordinated with the Forms and Procedures Office to ensure conformance with and incorporation into the Department's **Standard Operating System**.

1.9 Training

There is no mandatory training required.

1.10 Forms Access

There are no forms related to this manual.

Chapter 2

Open Channel

2.1 Introduction

This chapter presents standards for the design of artificial or manmade open channels, including roadside ditches, median ditches, interceptor ditches, outfall ditches, and canals.

2.2 Design Frequency

Open channels shall be designed to convey, without damage, and to confine within the ditch, stormwater flow with standard design frequencies as follows:

TYPE CHANNEL	FREQUENCY
Roadside, Median, and Interceptor ditches or swales	10-year
Outfalls (piped or open)	25-year
Canals	25-year
Temporary roadside and median ditches or swales	2-year
Temporary Outfalls and Canals	5-year

Site-specific factors may warrant the use of an atypical design frequency. Any increase over pre-development stages shall not change offsite land use values, unless flood rights are acquired.

2.3 Hydrologic Analysis

Hydrologic data used for the design of open channels shall be based on one of the following methods, as appropriate, for the particular site:

1. A frequency analysis of observed (gage) data shall be used when available. If insufficient or no observed data is available, one of the procedures below shall be used as appropriate. However, the procedures below shall be calibrated to the extent practical with available observed data for the drainage basin, or

-
- nearby similar drainage basins.
- a. Regional or local regression equation developed by the USGS.
 - b. Rational Equation for drainage areas up to 600 acres.
 - c. For outfalls from stormwater management facilities, the method used for the design of the stormwater management facility may be used. See **Chapter 5** for hydrologic methods that may be used for the design of stormwater management facilities.
2. For regulated or controlled canals, hydrologic data shall be requested from the controlling entity. Prior to use for design, this data shall be verified to the extent practical.

2.4 Hydraulic Analysis

The Manning's Equation shall be used for the design of open channels.

2.4.1 Manning's "n" Values

Manning's n values for channels with bare soil and vegetative linings are presented in **Table 2.1**. Manning's n values for rigid linings are presented in **Table 2.2**.

The probable condition of the channel when the design event is anticipated shall be considered when a Manning's n value is selected. Ditches with bottoms designed at or near the seasonal high groundwater level shall use the higher "n" values to account for increased vegetation growth occurring between extended maintenance periods.

2.4.2 Slope

For ditches where positive flow conditions are required, a minimum physical slope of 0.0005 ft/ft shall be used.

2.4.3 Channel Linings and Velocity

The design of open channels shall determine the need for channel linings. Standard lining types are shown in **Design Standard Index 281 and Standard Specifications for Road and Bridge Construction Section 985**. Maximum velocities for the various forms of channel lining are given in **Tables 2.3 and 2.4**. When design flow velocities do not exceed the maximum permissible for bare earth as given in **Table 2.3**, standard treatment of ditches consists of grassing and mulching. For higher design velocities, sodding, ditch paving, or other form of lining consistent with **Tables 2.3 and 2.4** shall be provided.

Shear stress shall be checked at locations of steep slopes (>1%) such as ditch flow down a pond slope, gore drainage, and offsite flow entering the right of way via the back slope of a roadside swale.

The *Open Channel Handbook* provides additional guidance on types of lining materials as well as the proper application of various types of linings.

2.4.3.1 Limitations on Use of Linings

2.4.3.1.1 Grassing and Sodding

Grassing or sodding shall not be used under the following conditions:

1. Continuous standing or flowing water
2. Areas that do not receive the regular maintenance necessary to prevent domination by taller vegetation
3. Lack of nutrients and excessive soil drainage
4. Areas excessively shaded

2.4.3.1.2 Concrete Lining

To prevent cracking or failure, concrete lining must be placed on a firm, well-drained foundation. Concrete linings shall not be used where expansive clays are present.

When concrete linings are to be used where soils may become saturated, the potential for buoyancy shall be considered. Acceptable countermeasures include:

1. Increasing the thickness of the lining to add additional weight.
2. For sub-critical flow conditions, specifying weep holes at appropriate intervals in the channel bottom to relieve the upward pressure on the channel.
3. For super-critical flow conditions, using subdrains in lieu of weep holes.

2.4.3.1.3 Asphalt Lining

Asphalt linings are for maintenance activities only and are not allowed for design projects.

2.4.3.1.4 Turf Reinforcement Mat (TRM)

Turf reinforcement mats shall not be used where high siltation is expected. During

desilting operations the TRM may be damaged.

2.4.4 Channel Bottom

The minimum channel bottom width is 5 ft to accommodate mitered end sections and maintenance mowers. V-bottom ditches are not allowed due to their vulnerability to fill with silt unless both front and back slopes are 1:6 or flatter.

The minimum ditch bottom elevation shall be 1 foot above the estimated seasonal high groundwater elevation for maintainability. Fine grained soils may require more than 1 ft. clearance from the seasonal high groundwater to enable mowing.

2.4.5 Channel Freeboard

Provide a minimum of 1 ft of channel freeboard above the design stage within the channel if in a fill slope and 0.5 ft. if the channel is in a cut slope. If a channel is hydraulically connected to or part of the stormwater management facility, provide no less than 1 foot of channel freeboard above the peak design stage of the downstream, hydraulically connected pond. Consider downstream tailwater in freeboard calculations.

2.5 Construction and Maintenance Considerations

The design of an open channel shall be consistent with the standard construction and maintenance practices of the Department. Standard ditch linings are detailed in the ***Design Standard Index*** drawings and Standard Specifications. In the event the standard index drawings and specifications are not suitable for a specific project need, a detailed design shall be developed. This information must be specified in the design documents.

Ditches, outfall ditches retention/detention areas, and other drainage related features must be provided with berms and other physical access devices that facilitate maintenance activities. Consideration shall be given to future expansion of the facilities and to possible increased maintenance requirements. Absolute minimum values should only be used in extremely stable areas, in areas requiring infrequent maintenance, or in areas where existing physical constraints require their use. Berms should be based at the narrowest point; right-of-way should be reasonably uniform. If double ditches are specified, the minimum berm width between the two ditches is 10 feet if the ditches are dry, 15ft if the ditches are wet, for maintenance access. Contact the local maintenance office for minimum access requirements when the minimum berm width is not feasible

2.6 Safety

2.6.1 Protective Treatment

Drainage designs shall be reviewed to determine if some form of protective treatment will be required to prevent entry to facilities that present a hazard to children and, to a lesser extent, all persons. General criteria are provided in **Section 3.7**. Protective treatment for open channels in the form of fencing shall be considered when a potential hazard exists.

2.6.2 Roadside Safety

The design and location of open channels shall comply with roadside safety and clear zone requirements. See the **Plans Preparation Manual** for clear zone requirements, including special clearance criteria for canals.

2.7 Documentation

Design documentation for open channels shall include the hydrologic analysis and the hydraulic analysis, including analysis of channel lining requirements. For roadside ditches, the required standard format for documentation is provided in **Figure 2-1**.

Table 2.1
 Manning's "n" Values for Artificial Channels
 with Bare Soil and Vegetative Linings

<u>Channel Lining</u>	<u>Description</u>	<u>Design "n"</u>
Bare Earth, Fairly Uniform	Clean, recently completed	0.02
Bare Earth, Fairly Uniform	Short grass and some weeds	0.03
Dragline Excavated	No Vegetation	0.03
Dragline Excavated	Light Brush	0.04
Maintained Grass or Sodded Ditches	Good stand, well maintained 2 - 6"	0.06
Channels not Maintained	Clear bottom, brush sides	0.08
Channels not Maintained	Dense weeds to flow depth	0.1
Maintained Grass or Sodded Ditches	Fair stand, length 12" - 24"	0.2

* Decrease 30 percent for flows > 0.7' depth (max flow depth 1.5')

Table 2.2

Manning's "n" Values for Artificial Channels with Rigid Linings

<u>Channel Lining</u>	<u>Description</u>	<u>Design "n"</u>
Concrete Paved	Broomed*	0.016
Concrete Paved	"Roughened" - Standard	0.020
Concrete Paved	Gunite	0.020
Concrete Paved	Over Rubble	0.023
Rubble Riprap	Ditch Lining	0.035
Asphalt Concrete	Smooth	0.013
Asphalt Concrete	Rough	0.016

* Broomed is not the standard finish and must be specified when used (see **Section 524-7 of *Standard Specifications***)

Table 2.3
 Maximum Shear Stress Values
 and Allowable Velocities for Different Soils

<u>Soil Type</u>	<u>Shear Stress (psf)</u>	<u>Allowable Velocity</u> for a flow depth of about 3 ft. (ft/sec)
Silt or Fine Sand	0.027	1.50
Sandy Loam	0.037	1.75
Silt Loam	0.048	2.00
Firm Loam	0.075	2.50
Stiff Clay	0.260	3.75
Hardpans	0.670	6.00

Reference: University of Florida (1972)

Table 2.4
 Maximum Velocities for Various Lining Types

<u>Lining Type</u>	<u>Maximum Velocity (fps)</u>
Grass with Mulch	Bare Soil (Table 2.3)
Sod	4 ^{***}
Staked Sod	5
Lapped Sod	5.5
Erosion Control Blanket (Biodegradable, Spec Section 104-6)	6.5
Plastic Erosion Mat (Permanent, Spec Sections 571 and 985)	
- Type 1	10
- Type 2	14
- Type 3	18
Riprap (Rubble)(Ditch Lining)	6
Other flexible	FHWA HEC-15
Geotextile Grid	4 - 8*
Rigid	10 ^{**}

* Varies with grid

** Higher velocities acceptable with provisions for energy dissipation

*** If long term turf density is expected to be poor, use 3 fps maximum velocity

FLORIDA DEPARTMENT OF TRANSPORTATION
 HYDRAULIC WORKSHEET FOR ROADSIDE DITCHES

Road: _____
 Project Number: _____

Sheet _____ of _____
 Prepared by: _____ Date: _____
 Checked by: _____ Date: _____

STATION TO STATION	SIDE	% Slope	Drain Area	"C"	t _c	i ₁₀	Q (cfs)	Ditch Section			"n"	"d"	"d _{allowed} "	Vel. (fps)	Ditch Lining	Side Drain Pipe Dia.	Remarks
								F.S.	B.W.	B.S.							

Note: F.S. = Front Slope

B.W. = Bottom Width

B.S. = Back Slope

Figure 2-1

Chapter 3

Storm Drain Hydrology and Hydraulics

3.1 Introduction

This chapter presents minimum standards for the design of FDOT storm drain systems.

3.2 Pipe Materials

Pipe material selection shall be in accordance with **Chapter 6** of this manual.

3.3 Design Frequency

Standard design storm frequencies for the design of storm drain systems are as follows:

TYPE STORM DRAIN	FREQUENCY
General design	3-year
<ul style="list-style-type: none">• General design work that involves replacement of a roadside ditch with a pipe system by extending side drain pipes• General design on work to Interstate Facilities	10-year
<ul style="list-style-type: none">• Interstate Facilities for which roadway runoff would have no outlet other than a storm drain system, such as in a sag inlet or cut section• Outlets of systems requiring pumping stations	50-year

Site-specific factors may warrant the use of atypical design frequency. Any increase over pre-development stages shall not significantly change land use values, unless flood rights are acquired.

If a system has both curb inlets and ditch bottom inlets (DBI's), the HGL for the DBI's shall be checked for a 10-year design frequency and all structures in the mixed system shall meet the 3-year design frequency.

3.4 Design Tailwater

For the determination of hydraulic gradient and the sizing of storm drain conduits a tailwater elevation, which can be reasonably expected to occur coincident with the design storm event shall be used. Standard design tailwater conditions for the design of storm drain systems are as follows:

Crown of pipe at the outlet, or if higher:

Lakes -----	Normal High Water
Rivers and Streams --	Normal High Water
Stormwater Ponds ----	Peak stage in the pond during the storm drain design event. See Chapter 5 for routing requirements. Assume all orifices and v-notches to be frequently clogged for the purposes of establishing the design tailwater for storm drain systems connected to ponds.
Tidal Bays -----	Mean High Tide*
Ditches Free flowing --	Normal depth flow in the ditch at the storm drain outlet for the storm drain design storm event. (May differ from ditch design storm event.)
Downstream control --	The higher of: the stage due to free flow conditions (described above) or, the maximum stage at the storm drain outlet due to backwater from the downstream control using flows from the storm drain design storm event.
Existing Systems -----	Elevation of hydraulic grade line of the system at the connection for the design storm event
French Drains -----	Design Head over the outlet control structure
Closed Basin -----	Varies, depending on site specific conditions
Regulated Canals ----	Agency regulated control elevation

3.4.1 Sea Level Rise

The design of coastal projects (including new construction, reconstruction and projects rebuilding drainage systems) must include a sea level rise analysis to assess impacts to design. The sea level rise data listed below is based on historical tidal records gathered by National Water Level Observation Network (NWLON) and managed by the National Oceanic and Atmospheric Administration (NOAA):<http://tidesandcurrents.noaa.gov/sltrends/sltrends.html>

NOAA manages fourteen tidal gauge stations located around the state of Florida. Use the station nearest the site for analysis. Analysis must consist of straight line regression equation extrapolation based on the design service life of the project. Consider existing system criticality/vulnerability and project costs when implementing this best practice analysis.

Station ID	Station Name	MSL Trends (mm/yr)	+/- 95% CI (mm/yr)	Latitude	Longitude
8720030	Fernandina Beach, FL	2.01	0.18	30.6717	-81.465
8720218	Mayport, FL	2.44	0.27	30.3967	-81.43
8721120	Daytona Beach Shores, FL	2.32	0.63	29.1467	-80.9633
8723170	Miami Beach, FL	2.39	0.43	25.7683	-80.1317
8723970	Vaca Key, FL	3.18	0.49	24.7117	-81.105
8724580	Key West, FL	2.31	0.15	24.5557	-81.8079
8725110	Naples, FL	2.4	0.48	26.1317	-81.8075
8725520	Fort Myers, FL	2.63	0.51	26.6477	-81.8712
8726520	St. Petersburg, FL	2.54	0.26	27.7606	-82.6269
8726724	Clearwater Beach, FL	2.99	0.64	27.9783	-82.8317
8727520	Cedar Key, FL	1.89	0.18	29.135	-83.0317
8728690	Apalachicola, FL	1.76	0.69	29.7267	-84.9817
8729108	Panama City, FL	1.6	0.67	30.1523	-85.6669
8729840	Pensacola, FL	2.19	0.23	30.4044	-87.2112



3.5 Hydrologic Analysis

The Department requires use of the Rational Method for performing hydrologic calculations for storm drains. When storm drain systems are integrated with French drain systems or ditch storage systems, calculations may be performed using hydrographs to account for storage.

3.5.1 Time of Concentration

A minimum time of concentration of 10 minutes shall be used.

3.6 Hydraulic Analysis

Hydraulic calculations for determining storm drain conduit sizes shall be based on open channel and pressure flow as appropriate. The Manning's equation shall be used.

3.6.1 Pipe Slopes

The physical slope shall be that which will produce a velocity of at least 2.5 feet per second (fps) when the storm drain is flowing full. In areas of flat terrain where 2.5 fps is not feasible, an absolute minimum velocity of 2.0 fps for full flow shall be obtained.

Modification for Non-conventional Projects:
--

Delete last sentence in paragraph above and see the RFP for requirements.

For pressure flow storm drain systems, the minimum physical slope shall be 0.1%.

3.6.2 Hydraulic Gradient

Include friction losses in the computation of the design hydraulic gradient for all storm drain systems. Energy losses associated with special pollution control structures (weirs, baffles, etc.) and due to utility conflict structures shall also be included when present in storm drain systems.

When hydraulic calculations include only the major losses such as those described above and do not include all minor energy losses, the elevation of the hydraulic gradient for design storm conditions shall be at least 1 foot below the theoretical gutter elevation (i.e. 1.13' below the edge of pavement for Type E or F Curb). This does not apply to ditch bottom inlets and other similar conditions where temporary ponding or overload is acceptable. However, any increase over pre-development stages shall not adversely change offsite land use values, unless flood rights are acquired.

If all major and minor energy losses are calculated, it is acceptable for the hydraulic gradient to reach the gutter elevation. Minor losses include: entrance, exit, junction and manhole, expansion, contraction, and bend.

Minor losses shall be included in hydraulic calculations when the velocity is greater than 7.5 fps. Check total minor losses for systems longer than 2000 ft. to ensure that the minor losses do not exceed the 1 ft. allowance. If greater than 1 ft., use calculated minor losses to design the system.

If hydraulic calculations show that intermediate manholes are under pressure, specify that the manhole lids are bolted down.

3.6.3 Outlet Velocity

When the outlet velocity for the design storm discharge exceeds 4 fps, the need for special channel lining (revetment or armoring) and/or energy dissipation shall be evaluated for the need for protection against undesirable scour. For computation of the outlet velocity, the lowest anticipated tailwater condition that can be reasonably expected to occur during a storm event shall be assumed.

In areas where turf sustainability may be an issue, coordinate with maintenance to determine appropriate channel lining material.

3.6.4 Manning's Roughness Coefficients

Values for Manning's roughness coefficient are as follows:

Concrete Box Culverts	n = 0.012
Concrete Pipes	n = 0.012

Metal Pipes:

Pipe and Pipe Arch - Helical Fabrication	
Re-corrugated Ends - All Flow Conditions*	
12" to 24"	n = 0.020
30" to 54"	n = 0.022
60" and larger	n = 0.024

Pipe and Pipe Arch - Spiral Rib Fabrication	
Re-corrugated Ends - All Flow Conditions*	
All Sizes	n = 0.012

Plastic Pipes:

Polyvinyl Chloride-PVC (external rib/smooth interior)	
All Sizes	n = 0.012
Polyethylene (All Sizes)	
Single Wall	n = 0.024
Double Wall (Smooth)	n = 0.012
Polypropylene (All Sizes)	
Single Wall	n = 0.024
Double & Triple Wall (Smooth)	n = 0.012

* "Spiral" flow will not occur for most design situations. Therefore "spiral" flow design values have not been established. Values for spiral flow, as recommended by the Southeast Corrugated Steel Pipe Association, are contained in the *AISI Handbook of Steel Drainage & Highway Construction Products*.

3.7 Hydraulic Openings and Protective Treatment

Inlets and other hydraulic structures shall be selected/designed to satisfy hydraulic capacity, structural capacity, safety (vehicular, pedestrian, cyclist) and durability requirements.

Alternate "G" (hot dipped galvanized) grates and frames shall be required when the structure is located on any barrier island, the Florida Keys, or within ½ mile of any body of brackish water containing chlorides > 2000 ppm.

Drainage designs shall be reviewed to determine if some form of protective treatment will be required to prevent entry to long or submerged storm drain systems, steep ditches, or water control facilities. Protection shall also be evaluated in systems that have partial submergence at the entrance and full submergence at locations farther along in the system. If other modifications, such as landscaping or providing flat slopes, can eliminate the potential hazard and thus the need for protective treatment, they should be evaluated first. Vehicular and pedestrian safety are attained by differing protective treatments, often requiring the designer to make a compromise in which one type of protection is more completely realized than the other. In such cases, an evaluation shall be made of the relative risks and dangers involved to provide the design that gives the best balance. It must be remembered that the function of the drainage feature will be essentially in conflict with total safety, and that only a reduction rather than elimination of all risk is possible.

The three basic types of protective treatment used by the Department are:

<u>Feature</u>	<u>Typical Use</u>
Grates	To prevent persons from being swept into long or submerged drainage systems.
Guards	To prevent entry into long sewer systems under no-storm conditions, to prevent persons from being trapped.
Fences	To prevent entry into areas of unexpected deep standing water or high velocity water flow, or in areas where grates or guards are warranted but are unsuitable for other reasons.

When determining the type and extent of protective treatment, the following considerations shall be reviewed:

- The nature and frequency of the presence of children in the area, e.g., proximity to schools, school routes, and parks, should be established.
- Protective treatment is typically not warranted within a limited access highway; however, drainage facilities located outside the limited access area or adjacent to a limited access highway shall be considered unlimited access facilities.
- Adequate debris and access control are required on all inlet points if guards or grates are used at outlet ends.
- Hydraulic determinations, such as depth and velocity, shall be based on a 25-year rainfall event.
- The hydraulic function of the drainage facility must be checked and adjusted so the protective treatment will not cause a reduction in its effectiveness.
- Use of a grate may cause debris or persons to be trapped against the hydraulic opening. Grates for major structures shall be designed in a manner that allows items to be carried up by increasing flood stages.
- Use of a guard may result in a person being pinned against it. A guard is usually used on outlet ends.
- A fence may capture excessive amounts of debris, which could possibly result in its destruction and subsequent obstruction of the culvert. The location and construction of a fence shall reflect the effect of debris-induced force.

3.7.1 Entrance Location and Spacing

3.7.1.1 Inlets

Inlet type, location and spacing shall consider the following:

1. Inlet capacity and width of spread.
2. Movement of vehicles to and from adjacent property on turnouts.
3. Pedestrian and Bicycle Safety
4. Maximum pipe length without maintenance access (**Section 3.10.1**)
5. Roadway Geometry (e.g. superelevation transitions, roadway profile, etc.)
6. Hydraulic efficiency of the system
7. Potential for flooding of off-site property
8. Potential for low points at turn lanes and bus bays
9. Maintenance accessibility
10. Potential for concentrated flow to cause erosion when it leaves the pavement.

Inlets shall be placed at all low points in the gutter grade and/or ditch, and as appropriate at intersections, median breaks, and on side streets where drainage would adversely flow onto the highway pavement.

Inlet spacing shall be based on spread standards which are provided below in **Section 3.9**.

Inlets shall also be placed ten to twenty feet prior to the level section in superelevation transitions, to avoid concentrated flows across the pavement.

Curb inlets, including inlet transitions shall not be located within handicap drop curb locations or on curb returns.

Inlets in sag vertical curves that have no overflow outlet other than the storm drain system, (i.e. barrier wall, bridge abutment, cut sections) must have flanking inlets on one or both sides. The flanking inlets shall be located to satisfy spread criteria when the sag inlet is blocked.

Modification for Non-conventional Projects:
Trench drains are not allowed for the final constructed condition unless approved by the District Drainage Engineer. Trench drains are only allowed for temporary drainage.

Parking lot drainage shall consider the following:

1. Curb inlets are not to be used in areas of heavy pedestrian traffic; specifically service plaza parking lots. Alternately, ditch bottom inlets may be used with pedestrian rated grates.
2. Ditch bottom inlets shall be placed in the center of the travel lanes and not in hidden locations such as parking spaces.
3. Parking lots shall be graded away from the heaviest pedestrian areas to more remote locations where the ditch bottom inlets should be placed. Alternately, cuts in the curb may be used to allow pavement to drain into grassed swales prior to entering ditch bottom inlets.

3.7.2 Manholes

Manholes shall be placed outside of the wheel path of vehicles.

3.7.3 Shoulder Gutter

- Shoulder gutter is required on embankment higher than 20 ft (6.1 m) and on embankment higher than 10 feet where the longitudinal slope is greater than 2 percent. See the ***Plans Preparation Manual*** for standard slopes.
- Shoulder gutter is required on interchange and grade separation embankments higher than 5 ft with slopes steeper than 1:6 to minimize erosion.
- Shoulder gutter is required at bridge ends where concentrated flow from the bridge deck would otherwise run down the fill slope.
- Shoulder gutter is required in areas of guardrail where embankment slopes are steeper than 1:4 and any pavement is sloped towards the embankment.
- Where shoulder gutter is required per the above criteria, special profiles shall be developed in areas of roadway cross slope transitions and at roadway-bridge interfaces to see that stormwater is properly drained and not trapped.

3.7.4 Inlet Placement

CURB INLET and GUTTER INLET APPLICATION GUIDELINES

INDEX NO	INLET TYPE	TYPE CURB/GUTTER	GRADE CONSIDERATION	BICYCLE COMPATIBLE	ACCEPTABLE IN AREAS OF OCCASIONAL PEDESTRIAN TRAFFIC (6)	Notes
210	1	E & F	Continuous	Yes	Yes	
	2 [1]	E & F	Sag	Yes	Yes	
	3	E & F	Continuous	Yes	Yes	
	4 [1]	E & F	Sag	Yes	Yes	
211	5	E & F	Continuous	Yes	Yes	
	6 [1]	E & F	Sag	Yes	Yes	
212	7	Separator I & II	Continuous or Sag	Yes	Yes	
213	8	Separator IV & V	Continuous or Sag	Yes	Yes	
214	9 [2]	D & F	Continuous or Sag	Yes	Yes	
215	10 [2]	D & F	Continuous or Sag	Yes	Yes	
217	1	Median Barrier Wall	Continuous	No	Yes [4]	
	2 [1]	Median Barrier Wall	Sag	No	Yes [4]	
	3	Median Barrier Wall [3]	Continuous	No	Yes [4]	
	4 [1]	Median Barrier Wall [3]	Sag	No	Yes [4]	
	5 [1]	Median Barrier Wall [3]	Continuous & Sag	No	Yes [4]	
218	-	Barrier Wall	Continuous or Sag	No [5]	Yes	See Index 218 Inset B
219	-	Barrier Wall (Rigid, C & G)	Continuous or Sag	No [5]	Yes	See Index 219 Inset B & C
220	S	Shoulder	Continuous	No [5]	Yes	See Index 220 Bar Stub Detail
221	V	Valley	Continuous or Sag	No [5]	Yes	

- [1] Double throated inlets are usually not warranted unless the minor gutter flow exceeds 50 ft in length or 0.5 CFS.
- [2] Curb Inlets 9 and 10 are to be used only where flows are light and right of way does not permit the use of throated curb inlets.
- [3] These are double inlets; one on each side of the barrier wall.
- [4] May be used by specifying the reticuline grate.
- [5] Bicycle compatible provided a minimum 4ft riding surface is provided around the inlet, with a preferred 1 ft offset from the inlet. Consider use of pavement markings shown in the 2009 MUTCD to alert cyclist to the inlet in the bicycle lane or shoulder pavement.
- [6] These inlets are not acceptable in pedestrian ways, but may be used in areas subject to occasional pedestrian traffic are pavement, grassed, or landscaped areas where pedestrians are not directed over the inlet and can walk around the inlet.

DITCH BOTTOM AND MEDIAN INLET APPLICATION GUIDELINES

INDEX NO.	INLET TYPE	TRAFFIC	BICYCLE COMPATIBLE	ACCEPTABLE IN AREAS OF OCCASIONAL PEDESTRIAN TRAFFIC [5]
230	A	Heavy Wheel Loads	No	No
231	B	Heavy Wheel Loads	No	Yes
232	C [3]	Infrequent Traffic	Yes [6]	Yes [4]
	D	Infrequent Traffic	Yes [6]	Yes [4]
	E	Infrequent Traffic	Yes [6]	Yes [4]
	H	Infrequent Traffic	Yes	Yes
233	F	Heavy Wheel Loads	Yes	Yes
	G	Heavy Wheel Loads	Yes	Yes
234	J	Heavy Wheel Loads	No	Yes
235	K	N/A	N/A	N/A

- [1] Alternate G grates should be specified when in salt-water environment.
- [2] Inlets with slots are more debris tolerant than inlets without slots. Debris may buildup on Type B fence of Type K Inlet.
- [3] For Back of Sidewalk Location See Index No. 282.
- [4] Slotted inlets located in areas accessible to pedestrians must have traversable slots.
- [5] These inlets are not acceptable in pedestrian ways, but may be used in areas subject to occasional pedestrian traffic are pavement, grassed, or landscaped areas where pedestrians are not directed over the inlet and can walk around the inlet.
- [6] Inlets with traversable slots shall not be used in areas subject to bicycle traffic.

Drainage End Treatment - Lateral Offset Criteria

INDEX	STRUCTURE DESCRIPTION	LATERAL OFFSET CRITERIA ^[1]
210 to 221	Curb, Barrier & Gutter Inlets	Permitted within Clear Zone
230 to 231	Ditch Bottom Inlets – (Types A ^[2] and B) ^[3]	
232	Ditch Bottom Inlets – (Types C, D, E and H) ^[3] ^[4]	Permitted within Clear Zone
	Ditch Bottom Inlet - Type H w/Slot	Outside Clear Zone
233 & 234	Ditch Bottom Inlets – (Types F, G and J) ^[3]	Permitted within Clear Zone
235	Ditch Bottom Inlet - Type K	Outside Clear Zone
250 to 255	Straight Concrete Endwalls	Outside Clear Zone See Design Standards Index for "Location Reference"
258	Straight Sand - Cement Endwalls	
260	U-Type Concrete Endwalls With Grates - 15" to 30" Pipe	Permitted within Clear Zone for Low Design Velocities & Negligible Debris
261	U-Type Concrete Endwalls Baffles and Grate Optional - 15" to 30" Pipe	Permitted within Clear Zone w/Grate
264	U-Type Concrete Endwall Energy Dissipator - 30" to 72" Pipe	Outside Clear Zone See Design Standards Index for "Location Reference"
266	Winged Concrete Endwalls - Single Round Pipe	

268	U-Type Sand-Cement Endwalls	
270	Flared End Section	≤ 15" Diameter Inside Clear Zone > 15" Diameter Outside Clear Zone
272	Cross Drain Mitered End Section	≤ 24" Diameter Inside Clear Zone ^[5] > 24" Diameter Outside Clear Zone
273	Side Drain Mitered End Section	Permitted within Clear Zone
282	Back of Sidewalk Drain	Permitted within Clear Zone for Urban Curb & Gutter Sections Only with Design Speed ≤ 45 mph
289 to 292	Concrete Box Culvert - End Treatments	Outside Clear Zone
273	Safety Modifications for Endwalls	Permitted within Clear Zone w/Grate

- [1] Lateral Offset Criteria for Vehicular Traffic only. Additional considerations may be needed for Pedestrian or Bicycle Traffic. See Design Standards for additional information.
- [2] Designed for use on limited access facilities where debris may be a problem.
- [3] When Slots are required due to debris considerations, the inlet must contain a Traversable Slot design to be located within Clear Zone. See Design Standards for Traversable Slot designs.
- [4] Designs intended for areas of infrequent traffic loading.
- [5] Equivalent size Pipe Arch or Elliptical pipes are permitted within Clear Zone.

3.8 Grades

3.8.1 Longitudinal Gutter Grade

The minimum longitudinal gutter grade is 0.3 percent.

3.9 Spread Standards

3.9.1 Spread for Permanent Construction

The spread resulting from a rainfall intensity of 4.0 inches per hour shall be limited as follows.

Typical Section Condition	Design Speed (mph)	Spread Criteria*
Parking Lane or Full Width Shoulders	All	No encroachment
All Other	Design speed \leq 45	Keep $\frac{1}{2}$ of lane clear
	45 < Design Speed \leq 55	Keep 8' of lane clear
	Design Speed > 55	No encroachment

* The criteria in this column apply to travel, turn, or auxiliary lanes adjacent to barrier wall or curb, in normal or super elevated sections. For spread calculations in left turn lanes, per Index 310, assume a turn lane entry speed of 10 mph less than the roadway design speed.

In addition to the above standards, for sections with a shoulder gutter, the spread resulting from a 10-year frequency storm shall not exceed 1' 3" outside the gutter in the direction toward the front slope. This distance limits the spread to the face of guardrail posts. See ***Design Standard Index 400***.

3.9.2 Spread for Temporary Construction

Design temporary drainage, for traffic diversions and construction staging, to provide drainage where construction activities might divert or trap water and compromise safety and efficiency. Additional attention shall be given to expected spread for areas that are (1) flood sensitive, (2) high speed facilities (> 55 mph posted speed), or (3) using low side barrier wall.

3.10 Construction and Maintenance Considerations

The design of storm drain systems shall be consistent with the standard construction and maintenance practices of the Department. Standard details for inlets, manholes, junction boxes, end treatments, and other miscellaneous drainage details are provided in the ***Design Standard*** index drawings. Specifications are provided in the ***Standard Specifications for Road and Bridge Construction***. In the event standard index drawings are not suitable for a specific project need, a detailed design shall be developed and included in the plans; and, as appropriate, special provisions shall be provided for inclusion with the project specifications. Proper design shall consider maintenance concerns of adequate physical access for cleaning and repair.

Drainage structures with topside access shall be placed at all pipe junctions where the pipe flow is designed to bend. Drainage structures with weirs shall have manhole access on each side of the weir. For areas of expected frequent entry, ask DOT Maintenance if a two piece, 3 ft diameter, manhole cover is needed for maintenance access.

Modification for non-conventional Projects:
--

Delete the last sentence in the paragraph above and see the RFP for additional requirements.
--

Outfall structures and structures with pollution retardant baffles or skimmers installed inside the structure are required to have a 4 ft minimum sump. When 2 or more baffles or skimmers are used in the same structure, a minimum horizontal distance of 2.5 feet shall be provided between baffles, for maintenance access. For submerged systems, where cleanout velocity is not maintained, use a 2 ft sump for all affected inlets.

For urban roadways with significant leaf drop potential and posted speed limit 40 mph or less, consider using a curb inlet screens to keep debris out of storm drain system. If a curb inlet screen is used, use a catch basin pipe connection screen in conjunction with curb inlet screens.

All constructed inlets and manholes, excluding closed French drain systems, must have an outlet storm drain pipe.

No storm drain pipe exiting a drainage structure will be constructed with a flow line higher than any storm drain pipe entering the same structure.

3.10.1 Pipe Size and Length

The minimum pipe size for trunk lines and laterals is 18". The minimum pipe diameter for

all proposed exfiltration trench pipes (French drain) is 24”.

The 18” minimum pipe size does not apply to connections from external, private stormwater management facilities. The pipe size for these connections shall be the size required to convey the Chapter 14-86, F.A.C. or other authoritative permitted discharge limitations .

The maximum pipe lengths without maintenance access structures are as follows:

Pipes without French Drains:

18” pipe	300 feet
24” to 36” pipe	400 feet
42” and larger and all box culverts	500 feet

French Drains that have access through only one end:

24” to 30” pipe	150 feet
36” and larger pipe	200 feet

French drains that have access through both ends:

24” to 30” pipe	300 feet
36” and larger pipe	400 feet

3.10.2 Minimum Clearances

The following minimum clearances shall be provided:

1. The minimum clearance between the outside crown of a pipe and the gutter elevation at the inlet shall be in accordance with standard index drawing requirements for the specified inlet. If this cannot be achieved, a special detail shall be provided in the plans.
2. Minimum cover for pipe shall be provided in accordance with **Appendix C**.
3. Storm drain systems that cross railroad tracks have special below-track clearance requirements and must use special strength pipe. See **Standard Index No. 280** for railroad company design requirements.
4. Utility Clearances:
 - a. When a utility crosses a storm drain alignment, the minimum design clearance between the outside of the pipe and the outside of the conflict

shall be 0.5 foot if the utility has been accurately located at the point of conflict. If the utility has been approximately located, the minimum design clearance shall be 1 foot. Utility company recommended clearances can vary from these design values, but electrical transmission lines and gas lines shall never come into direct contact with the storm drain.

- b. Storm drain lines shall be located to not disturb existing utilities to the extent practical. If a utility conflict occurs, the District Drainage Engineer and the Utilities Section shall be contacted to review potential problems and feasible solutions.
- c. When a sanitary line or other utility, including other storm drains, must pass through a manhole, minimum clearances in accordance with ***Design Standard Index 307*** shall be provided. The head loss caused by an obstruction shall be accounted for in the computation of the design hydraulic grade line. (Note: Gas mains shall not pass through inlet and manhole structures.)
- d. Utility conflict structures shall provide manhole access on both sides of the conflict when the conflicting utility is large ($\geq 12"$), or the conflict is close to the top of the structure. Maintenance vacuum trucks have a rigid suction pipe that cannot bend around obstructions. If the degree of access is uncertain, contact the local FDOT maintenance office for direction.
- e. The distance between the bottom of the utility and the conflict structure bottom shall be no less than the internal diameter of the outlet pipe. Use a 2 or 4 ft. sump in areas where sedimentation is expected. Use of a sump will require that the system be designed to account for the headloss generated if the sump is completely blocked.

3.10.3 Pipe Joint Designs Greater than 5 psi

When the pipe joints are expected to withstand design conditions greater than 5 psi but no more than 10 psi, include a plan note requiring the pipe supplier to test the proposed pipe joint to 10 psi using the methodology described in the Standard Specifications. If a pressure rating greater than 10 psi is desired, call for a pressure pipe in the plans including the needed ASTM(s) to clearly identify the pipe requirements.

3.11 Pipes within or Adjacent to Retained Earth (Walled) Embankment Sections

The design requirements of this section pertain to all pipes that are to be constructed within or adjacent to embankments confined by retaining walls. Avoid the placement of drainage pipes through retaining walls and similar structures when possible. If pipes must be placed within or adjacent to retaining walls, coordinate the design of the drainage system with the geotechnical and structural engineers.

The drawings in Appendix D detail three categories of pipes within retained earth (walled) embankments. Pipes proposed for installation within these wall zones are defined as Wall Zone Pipes.

The Optional Materials Tabulation Sheet must note those pipes that are deemed Wall Zone Pipes. When steel pipes are listed as an option for Wall Zone Pipes, the minimum pipe wall thickness, meeting the requirements of Appendix D, shall also be shown on the Optional Materials Tabulation Sheet.

Pipes used as vertical drains passing under or through retaining walls, must satisfy the structural requirements of AASHTO LRFD Bridge Design Specifications, Chapter 12.

When existing pipes are to be incorporated within or adjacent to retained earth embankments sections, assess the condition of the pipe – both water tightness and structural adequacy under the proposed loading – and confer with the geotechnical and structural engineers.

3.12 Additional Design Considerations

3.12.1 Noise Walls

Evaluate the capacity of drainage openings in noise walls and locate horizontally and vertically to ensure that offsite stormwater inflows are accommodated without increasing offsite stormwater stages for the appropriate regulatory design events. The drainage designer shall document the existing drainage patterns including taking photographs along the location of the proposed sound barrier. If the capacity and/or location of noise wall drainage openings are insufficient and cannot be amended to handle offsite inflows, a drainage system shall be designed to maintain historic flows and to minimize the maintenance required behind the wall especially for locations with limited right-of-way behind the wall.

3.12.2 French Drains

Exfiltration systems (French drains) shall be designed using Design ***Standard Index***

Drawing 285. Designs shall include provisions for overflow resulting from floods exceeding the design storm condition.

Baffles, skimmers and 4 ft minimum sumps must be provided at inlet points to minimize entrance of oil and sediments into the French drain system. Exfiltration trench shall not be located where there are contaminated soils and in well field protection zones with less than 30 days travel time to potable water supply wells. French drains are not allowed in embankments/fill conditions (not natural or compacted soil material).

A minimum of 10 ft must be provided between French drains and overhead sign foundations, drill shafts, light poles foundations or retaining walls. If this minimum distance cannot be met, the segment of perforated pipe and trench within the 10 ft of influence of the drill shaft or foundation must be replaced with a solid segment of pipe.

Stormwater exfiltration systems shall be installed at least 2 feet from parallel underground utilities and 20 feet from existing large trees to remain in place.

The depth and location of the French drain trench shall be established based on prudent benefit / cost considering the following factors:

1. Depth of transmissive strata that satisfy design needs
2. Safety, feasibility, and expected frequency of required French drain maintenance activities
3. Loss of functionality of the French drain due to its being under impervious surfaces.
4. Location of trees, utilities, and other features that may compromise the integrity of the trench envelope.
5. The cost of providing other stormwater management infrastructure in lieu of the French drain.
6. Cost of replacing the French drain in the future
7. Potential geotechnical failures in Karst areas

3.12.3 Resilient Connectors

All storm drain manholes and inlets may utilize resilient connectors as specified in Chapter 430 of the ***FDOT Standard Specifications for Road and Bridge Construction***.

Resilient connectors shall not be specified or required for the following conditions:

- The interface angle of connection between the structure and pipe is greater than 15 degrees, in either the horizontal or vertical direction.

-
- The structure and all connections which fall outside the 1:2 roadway template control line as per ***Design Standard Index 505***.
 - The remaining beam height of the single precast unit, from the top of that segment to the existing crown of pipe chosen, is less than 8 inches.
 - Where elliptical pipes are specified on the plans.

To accommodate movement of the bridge collection piping, resilient connectors shall be used when connecting bridge deck drainage piping to roadway drainage structures.

3.13 Documentation

3.13.1 Tabulation Form

The required format for tabulating the results of hydrologic and hydraulic calculations for storm drain systems is presented in ***Figure 3-1***. The minimum information for producing a storm tabulation form is also noted in ***Figure 3-1***. A copy of the completed form shall be filed for permanent record as a part of the signed and sealed design documentation. Descriptions and examples of the form content can be found in the ***Storm Drain Handbook***.

3.13.2 Other Documentation

Other supporting calculations and design documentation shall be filed, including:

1. For complex systems, a narrative describing how the storm drain system will function.
2. Hydrologic Computations:
 - a. Time of Concentration
 - b. Runoff Coefficients
3. Spread and Inlet capacity analysis
4. Determination of Design Tailwater
5. Optional materials evaluation
6. Computation of minor energy losses, if applicable
7. Completed Drainage Map with drainage areas to each inlet identified, and structures numbered consistent with drainage computations and tabs.
8. Outlet scour protection analysis, if applicable.

FLORIDA DEPARTMENT OF TRANSPORTATION STORM DRAIN TABULATION FORM

Financial Project Identification:
Description:

County:
Organization:

Network:
State Road:

Prepared:
Checked:

Date:
Date:

LOCATION OF UPPER END		STRUCTURE NO.		TYPE OF STRUCTURE	LENGTH (ft.)	DRAINAGE AREA (Acres)		SUB-TOTAL (C*A)	TIME OF CONCENTRATION (min)	TIME OF FLOW IN SECTION (min)	INTENSITY (in/hr)	TOTAL (C*A)	BASE FLOW (cfs) *	TOTAL FLOW (cfs)	MINOR LOSSES (ft.) ***	INLET ELEVATION (ft.)	HGL CLEARANCE (ft.) *	HYDRAULIC GRADIENT				NUMBER OF BARRELS *	PIPE SIZE (in.)	SLOPE (%)	NOTES AND REMARKS						
ALIGNMENT NAME		UPPER				INCREMENT	TOTAL													CROWN						RISE	HYD. GRAD.	ACTUAL VELOCITY (fps)	FULL FLOW CAPACITY (cfs) *	Zones	
STATION	DISTANCE (ft.)	LOWER																		UPPER END ELEVATION (ft.)	LOWER END ELEVATION (ft.)									PHYSICAL	FREQUENCY (Yrs):
STATION	DISTANCE (ft.)	SIDE	LOWER															UPPER	LOWER												

* Denotes optional information.
 ** A composite runoff coefficient may be shown in lieu of individual C-values, provided the composite C calculations are included in the drainage documentation.
 *** Required if Minor Losses are included

Figure 3-1

Chapter 4

Cross Drain Hydraulics

4.1 Introduction

This chapter presents standards and procedures for the hydraulic design of cross drains including culverts, bridge-culverts¹, and bridges. Preliminary planning and location studies for cross drains are addressed in the *FDOT Project Development and Environmental Manual*.

4.2 General

The hydraulic design of cross drains shall be done in accordance with good engineering practice and comply with **23 CFR 650**, Subpart A, and the *National Flood Insurance Program*. Specifically:

1. All cross drains shall be designed to have sufficient hydraulic capacity to convey the selected design frequency flood without damage to the structure and approach embankments, with due consideration to the effects of greater floods.
2. Bridge and bridge culvert FOUNDATIONS shall be designed with normal safety factors to withstand the scour design flood condition listed in Section 4.9.2.2, and shall have a minimum factor of safety of one against failure due to the scour design check flood condition listed in Section 4.9.2.2.
3. The design of all cross drain structures shall be analyzed for the Design Flood, Base Flood (100-year frequency flood) and the Greatest Flood (overtopping flood or the 500-year frequency flood where overtopping is not practicable) that can be expected to flow to the structure. A summary of this analysis showing the peak stages and discharges for these events shall be shown on the final project plans.
4. For projects that encroach into a Regulatory Floodway, the design shall be coordinated with the appropriate local government Flood Insurance Program official.

¹ A culvert qualifies as a bridge if it meets the requirements of Item 112 in the FDOT [“Bridge Management System Coding Guide.”](#)

4.2.2 LRFD Design Code Bridge Design Specifications

LRFD Design Code Bridge Design Specifications Section 2.6 is deleted in its entirety.

4.3 Design Frequency

4.3.1 Permanent Facilities

Standard design frequencies for permanent culverts, bridge-culverts and bridges are as follows:

FACILITY	FREQUENCY
Mainline Interstate	50 years
High Use or Essential: Projected 20 year AADT* > 1500,	50 years
Other: Projected 20 year AADT* < 1500,	25 years
<ul style="list-style-type: none"> • Roadside Ditch Culverts • Pedestrian and Trail Bridges 	10 years

* AADT preferred but if not available ADT may be utilized.

Note: The flood frequencies used for scour analysis differ. See **Section 4.9.2**.

4.3.2 Temporary Facilities

Temporary traversing works shall be designed accounting for the permitted duration of the traversing work. Temporary traversing work shall cause no more than a 1 foot increase in the Design Storm Frequency (DSF) flood elevation immediately upstream and no more than one tenth of a foot increase in the DSF flood elevation 500 feet upstream.

Minimum standard design frequencies for temporary culverts, bridge-culverts and bridges are as follows:

DURATION OF TRAVERSING WORK	FREQUENCY
≤ 13 Months	2 years
13-40 Months	5 years
40-85 Months	10 years
> 85 Months	Use the Permanent Facilities Table in Section 4.3.1

In lieu of the above table, the DSF may be determined using the equation:

$$DSF = 1 / [1 - (1 - R)^{1/N}]$$

where:

DSF = Design Storm Frequency,

N = Duration of Facility Usage in Years,

R = Risk of Occurrence of 100 year storm with a 75 year life span.

4.4 Backwater

The design of cross drain openings shall be consistent with backwater conditions as follows:

1. Backwater created by the structure shall be consistent with Flood Insurance Study requirements adopted by the local community in accordance with the **National Flood Insurance Program** and **FEMA** guidelines.
2. Any increase in backwater shall not significantly change offsite land use values, unless flood rights are acquired.
3. The backwater for design frequency conditions shall be kept at or below the travel lanes.

4.5 Tailwater

For the sizing of cross drains and the determination of headwater and backwater elevations, the highest tailwater elevation which can be reasonably expected to occur coincident with the design storm event shall be used.

* Adjust the MHW elevation for sea level rise using the methodology in Section 3.4.1.

4.6 Clearances

The minimum vertical, horizontal, and regulatory clearance requirements for bridges shall conform to the requirements shown in the *Plans Preparation Manual Volume 1* Chapter 2.

4.7 Hydrologic Analysis

4.7.1 Freshwater Flow

Hydrologic data for freshwater flow conditions used for the design of cross drains shall be based on one of the following methods as appropriate for the particular site:

1. A frequency analysis of observed (gage) data shall be used when available. If insufficient or no observed data is available, one of the procedures below shall be used as appropriate. However, the procedures below shall be calibrated to the extent practical with available observed data for the drainage basin or nearby similar drainage basins.
 - a. Regional or local regression equation developed by the USGS.
 - b. Rational Equation for drainage areas up to 600 acres.
2. For regulated or controlled canals, hydrologic data shall be requested from the controlling entity. Prior to use for design, this data shall be verified to the extent practical.

4.7.2 Tidal Flow

Hurricane rainfall runoff shall be considered in conjunction with surge-driven tailwater when analyzing creeks and small rivers flowing into tidal water bodies. In such cases, since hurricane rainfall is largely independent of peak surge stage, the Army Corps of Engineers (ACOE) tropical storm rainfall runoff procedure from the *1986 Engineering and Design Storm Surge Analysis Manual (EM1110-2-1412)*, Chapter 4, should be used to estimate runoff from any design surge regardless of the surge return frequency being analyzed. The above procedure may be found at the website:

<http://www.dot.state.fl.us/rddesign/Drainage/FCHC.shtm>

Alternatively, a steady discharge equal to the peak flow from a 10-year storm may be used in lieu of the above *ACOE procedure*.

4.8 Hydraulic Analysis

4.8.1 Riverine Crossings

4.8.1.1 Bridges

FHWA's FESWMS, and *U.S. ACOE's HEC-RAS, ADCIRC*, and *RMA-2*, are acceptable computer programs to analyze the hydraulic performance of bridges over riverine waterways.

4.8.1.2 Bridge-Culverts and Culverts

The hydraulic performance of bridge-culverts and culverts at riverine waterways shall be analyzed based on the techniques provided in *FHWA Hydraulic Design Series #5*.

4.8.2 Tidal Crossings

Coastal engineering analysis as typified by the U.S. Army Corps of Engineers and consistent with current coastal engineering practice shall be used in the analysis of astronomical tides and hurricane storm surges. The computer programs acceptable for hydraulic analyses at tidal crossing are *HEC-RAS, RMA-2, ADCIRC*, and *FESWMS*.

4.8.2.1 Ocean Boundary Hydrographs

When ocean coast hurricane hydrographs are used for driving surge models inland, stage / time hydrographs shall be used from the following website:

<http://www.dot.state.fl.us/rddesign/Drainage/dhsh.shtm>

Adjust the hurricane hydrograph for sea level rise using the methodology in Section 3.4.1.

4.8.2.2 Use of Qualified Coastal Engineers

If coastal hydraulics is significant to the bridge or culvert design, a qualified coastal engineer should review the complexity of the tidal conditions to determine the appropriate level of coastal engineering expertise needed in the design. Ideally, this review should be carried out in the PD&E phase as specified in the *FDOT PD&E Manual*, Chapter 4. Conditions that typically require direct attention by a coastal engineer during the final design phase are as follows:

-
- Hydraulic analysis of interconnected inlet systems
 - Analysis of inlet or channel instability, either vertically or horizontally
 - Determination of design wave parameters
 - Prediction of overwash and channel cutting
 - Design of countermeasures for inlet instability, wave attack or channel cutting
 - Prediction of sediment transport or design of countermeasures to control sediment transport
 - Assessment of wave loading on bridges and other structures

Modification for Non-conventional Projects:
--

Delete Section 4.8.2.2 and see the RFP for requirements.
--

4.9 Specific Standards Relating to Bridges

4.9.1 Berms for Spill-Through Abutment Bridges

To facilitate construction, reduce scour potential, and provide for abutment stability, a minimum berm width of 10 feet shall be provided between the top edge of the main channel and the toe of spill through bridge abutments. See **Section 4.9.3.2**. For manmade canals, the berm may be omitted at the direction of the maintaining agency.

4.9.2 Scour Estimates

4.9.2.1 Coordination

Scour estimates for bridges shall be developed using a multi-disciplinary approach involving the hydraulics engineer, the geotechnical engineer, coastal engineer (if needed per **Section 4.8.2**, above), and the structures engineer.

4.9.2.2 Scour Estimates

Scour elevation estimates for each bent shall be developed for the following:

Hydraulic Design Flood Frequency	Scour Design Flood Frequency	Scour Design Check Flood Frequency
Q ₁₀	Q ₂₅	Q ₅₀
Q ₂₅	Q ₅₀	Q ₁₀₀
Q ₅₀	Q ₁₀₀	Q ₅₀₀

- "Long term scour" for structures required to meet the extreme event vessel collision load.

Scour estimates shall be made using the procedures of *FHWA's Hydraulic Engineering Circulars (HEC) 18 and 20* except for the following:

- Tidal hydraulics analysis methodology shall follow **Section 4.8.2**.
- **Sheppard's Pier Scour Equation** shall be used rather than the **CSU Pier Scour Equation** when the total scour (general scour, contraction scour, and local scour) is greater than 5 feet.
- The **Florida Complex Pier Scour Procedure** shall be used in lieu of the complex pier scour procedure in **HEC 18**.
- The **Florida Rock / Clay Scour Procedure** shall be used to evaluate scour in scour resistant soils.
- **SED-2D** may be used to evaluate contraction scour in the absence of a clearly-defined upstream tidal floodplain. Guidance on the above Florida procedure may be found at the website:

<http://www.dot.state.fl.us/rddesign/Drainage/Bridge-Scour-Policy-Guidance.shtm>

4.9.2.3 Scour Components

Scour estimates for items number 1 and 2 above, shall consist of the total scour resulting from the following:

1. Natural Channel aggradation and degradation anticipated during the life of the structure.
2. Channel Migration anticipated during the life of the structure.
3. Contraction scour.
4. Local scour, including pier scour and abutment scour from currents and waves. (Note: Abutment scour estimates are not required when the minimum abutment protection is provided.)

The "long-term scour" is the total design scour for structures subject to clear water scour. For structures subject to live bed scour, the "long-term scour" is the normal, everyday scour at the piers combined with the degradation scour anticipated during the life of the structure. The following inset provides criteria for determining normal, everyday scour at the piers.

Normal, Everyday Scour at the Piers

For bridge replacements, parallel bridges, major widenings, etc., bridge inspection reports and the design survey shall be the primary basis for determining normal everyday scour.

If the proposed piers are the same as the existing, the normal, everyday scour elevation should be that which is reflected in the inspection reports and the design survey. Slight differences in scour will likely exist between inspection reports and between the reports and the design survey. In these cases, an average scour elevation will be a reasonable estimate of normal, everyday scour. If there is a large difference, it may be due to an extreme storm event that occurred just before the inspection or survey was made. Investigate this and address these situations on a case by case basis.

For structures in which the proposed piers will be a different size or shape than the existing, it is recommended that the pier scour depth be adjusted. Using the inspection reports and the survey as discussed above, determine a normal, everyday scour depth at the pier. Adjust this depth using the following formula. The formula was derived by assuming only the pier width and shape change. Flow, velocity and depth are unchanged from existing to proposed.

$$y_{sp} = \frac{k_{1p}}{k_{1e}} \left[\frac{a_p}{a_e} \right]^{0.65} y_{se}$$

where:

y_{sp} & y_{se} = scour depth for proposed pier and existing pier, respectively

k_{1p} & k_{1e} = pier nose shape correction factor for proposed and existing pier, respectively

a_p & a_e = pier width for proposed and existing pier, respectively

For new bridges/new alignments where there are no historical records available, the drainage engineer should look for hydraulically similar bridges in the area (preferably on the same water body) and estimate scour using the above guidelines. If there are no similar structures to use for comparison, contact the District Drainage Engineer for guidance on other methods for estimating normal everyday scour.

4.9.3 Scour Protection Considerations

4.9.3.1 General

Pier spacing and orientation, and abutment design shall be designed, balanced with other bridge design concerns, to minimize flow disruption and potential scour, subject to navigation requirements.

Abutment and pier protection shall be designed as follows:

1. For protection against the effects of scour conditions consistent with design requirements stated above.
2. For the effects of wind generated waves and boat wake.

Revetment options, deemed to be inappropriate for the site, shall be documented in the BHR. A Technical Specification, if needed, should be written based on the use of the most desirable revetment material, with the option to substitute the other allowable materials at no additional expense to the Department.

Specify the environmental classification for gabions based on the criteria found in the **Structures Manual, Volume 1: Structures Design Guidelines, Section 1.3**.

Follow *ACOE Shore Protection Manual* for design of coastal revetment.

4.9.3.2 Minimum Abutment Protection

For wave heights greater than 2.4 ft. (typically in coastal applications), use S.G. = 2.65 or greater rubble. In such cases, abutment protection shall be extended beyond the bridge along embankments that may be vulnerable to wave attack during a hurricane. Both wave attack above the peak design surge elevation and wave rebound scour at the toe of bulkheads must be considered. In such cases, a qualified coastal engineer shall be consulted to determine the size and coverage of the revetment.

4.9.3.2.1 Spill-through Abutments

For spill-through abutments, minimum protection shall consist of one of the following placed on a slope no steeper than 1(vertical) to 2 (horizontal):

- Rubble riprap (Bank and Shore), bedding stone, and filter fabric: Rubble riprap (Bank and Shore) as defined in the **Standard Specifications for Road and Bridge Construction, Section 530** where (1) design flow velocities do not

exceed 7.7 fps, (2) Froude numbers are ≤ 0.80 , and (3) wave heights do not exceed 2.4 feet.

- Articulated concrete block (cabled and anchored).
- Grout-filled mattress (articulating with cabling throughout the mattress).

Site specific designs and technical specifications are required when using articulated concrete block or grout-filled mattress abutment protection. The **Structures Detailing Manual** provides typical details for standard revetment protection of abutments and extent of coverage. The horizontal limits of protection shall be determined using **HEC-23**. A minimum distance of 10 feet shall be provided if **HEC-23** calculations show less than 10 feet.

4.9.3.2.2 Bulkhead Abutments

When bulkhead abutments are protected by a structural wall, consult with the structural engineer to determine the need for toe protection below the wall and revetment protection above the wall. When the design velocity in the contracted section is less than or equal to 7.2 fps, bank and shore rubble riprap shall be used. When the design velocity is above 7.2 fps, the size and density of the rubble shall be designed for site conditions. In all cases, the spatial extent of the rubble protection shall be designed for individual site conditions.

4.9.3.3 Pier Protection

Where revetment is deemed necessary to protect piers from scour, and upstream design flow velocities do not exceed 7.2 fps for rectangular piles or bascule piers, and 8.2 fps for round piling or drilled shafts, pier scour protection shall consist of one of the following:

- Rubble riprap (Bank and Shore), bedding stone, and filter fabric: Rubble riprap (Bank and Shore) is defined in the **Standard Specifications for Road and Bridge Construction, Section 530**.
- Articulated concrete block (cabled).
- Gabions (rock filled baskets)

Site specific designs and technical specifications are required when using articulated concrete block, gabions, or when using rubble and the design velocities exceed the above velocities.

4.9.3.4 Use of Bedding Stone with Revetments

Geotextile type and material referenced below is based on **FDOT Standard**

Specifications for Road and Bridge Construction Section 985.

Bedding stone is used to cushion the underlying filter fabric during installation of rubble and to keep the filter fabric flat against the parent soil to avoid the piping of sheet flow cascading from the top side of the rubble.

4.9.4 Bridge Deck Drainage

4.9.4.1 Spread Standards

The spread on bridge decks and bridge approaches shall meet the spread standards in the **Section 3.9**.

4.9.4.2 Scupper Drains

The standard scupper drain shall be 4" in diameter and spaced on 10foot centers, unless spread calculations indicate closer spacing is required. Scuppers should not be directly discharging onto railroads, roadway travel lanes, or shared use paths, or sidewalks.

4.9.4.3 Bridge Sidewalk Drainage

Where bridge sidewalks are sloped away from the travel lanes, measures to capture runoff from the sidewalks are not required. If bridge sidewalk drainage is installed, scuppers must satisfy Americans with disabilities Act (ADA) requirements to have no more than ½" 'hole' in the walking surface.

4.9.5 Wave and Current Forces on Coastal Bridges

Where coastal bridges are not elevated at least 1 ft. above the design wave crest elevation (DWC), a qualified coastal engineer with experience in wave mechanics shall address the requirements of **The AASHTO Guide Specifications for Bridges Vulnerable to Coastal Storms.**

4.9.5.1 Required Level of Analysis

A qualified coastal engineer shall assist in the PD&E scoping effort, especially with structures exposed to severe wave attack. Determinations, including the appropriate level of analysis, will be made as outlined in the **Structures Design Guidelines** Section 2.5.

4.10 Specific Standards relating to all Cross Drains except Bridges

4.10.1 Culvert Materials

Culvert material selection shall be in accordance with **Chapter 6** of this manual.

4.10.2 Manning's Roughness Coefficients

Standard values for Manning's roughness coefficient are as follows:

Concrete Box Culverts	n = 0.012
Concrete Pipes	n = 0.012

Metal Pipes:

Pipe and Pipe Arch - Helical Fabrication Re-corrugated Ends - All Flow Conditions*	
12" – 24"	n = 0.020
30" – 54"	n = 0.022
60" and larger	n = 0.024

Pipe and Pipe Arch - Spiral Rib Fabrication Re-corrugated Ends - All Flow Conditions*	
All Sizes	n = 0.012

Structural Plate - Pipe and Pipe Arch Annular Fabrication - All Flow Conditions*	
All - 6 x 2	n = 0.033
All - 9 x 2-1/2	n = 0.034

Plastic Pipes:

Polyvinyl Chloride-PVC (external rib/smooth interior) All Sizes	n = 0.012
--	-----------

Polyethylene Single Wall	n = 0.024
Double Wall (Smooth)	n = 0.012

Polypropylene (All Sizes)	
Single Wall	n = 0.024
Double & Triple Wall (Smooth)	n = 0.012

- * "Spiral" flow will not occur for most design situations. Therefore "spiral" flow design values have not been established. Values recommended by the Southeast Corrugated Steel Pipe Association are contained in the ***AISI Handbook of Steel Drainage & Highway Construction Products***.

4.10.3 End Treatment

The choice of end treatment and other hydraulic structures shall be selected/designed to satisfy hydraulic capacity, structural capacity, and safety (vehicular, pedestrian, cyclist) requirements.

Treatments are presented in the ***Standard Design Indexes of the Roadway and Traffic Design Standards***. The Standard Indexes provide criteria on end treatment selection.

4.10.3.1 Protective Treatment

Drainage designs shall be reviewed to determine if some form of protective treatment will be required to prevent entry to facilities that present a hazard to children and, to a lesser extent, all persons. Direction on protective treatment is presented in ***Section 3.7***. When grates are used, consideration shall be given to the effect of the grate and potential debris on the hydraulic capacity of the cross drain.

4.10.3.2 Roadside Safety

The type and location of end treatment shall comply with roadside safety and clear zone requirements. See the ***Plans Preparation Manual*** for clear zone requirements and the ***Design Standard Indexes*** for end treatment safety guidance.

4.10.4 Construction and Maintenance Considerations

The design of culverts shall be consistent with the standard construction and maintenance practices of the Department. Standard details for inlets, manholes, junction boxes, end treatments, and other miscellaneous drainage details are provided in the ***Design Standard index drawings***. Specifications are provided in the ***Standard Specifications for Road and Bridge Construction***. In the event standard index drawings are not suitable for a specific project need, a detailed design shall be developed and included in the plans; and, as appropriate, special provisions shall be provided for inclusion with the project specifications. Proper design shall also consider maintenance concerns of adequate physical access for cleaning and repair. The maximum pipe lengths without

maintenance access structures should meet the criteria found in **Section 3.10.1**.

4.10.4.1 Minimum Culvert Sizes

Minimum culvert sizes are as follows:

<u>Culvert Type</u>	<u>Minimum Size</u>
Cross Drain	18"
Median Drain	15" * **
Side Drain	15" *
Box Culvert (Precast)	3' x 3'
Box Culvert (Cast in Place)	4' x 4'
Drains from inlets on high fills (e.g., gutter drains)	15" **

* Some locations require 18" minimum. The designer shall consider future improvements, hydraulic requirements, debris control, and maintenance access.

** When debris control is not provided by grates, use 18" minimum.

For culverts requiring more than a double line of pipe, other alternatives shall be investigated.

4.11 Documentation

4.11.1 Culverts (all culverts less than a 20' bridge culvert)

4.11.1.1 Extensions of Culverts with No Known Historical Problems

For extensions of culverts that have no signs of undesirable scour at inlet and outlet ends; no excessive sedimentation; and no history of problems, the documentation shall include as a minimum the following:

1. Evidence of contact with Maintenance Office
2. Evidence of Field Review
3. Discharge Computations
4. Hydraulic Computations (HDS#5), including any design assumptions

4.11.1.2 New or Replacement Culverts and Extensions of Culverts with Known Historical Problems

At a minimum the documentation shall include:

1. Evidence of contact with Maintenance Office
2. Evidence of field review
3. Drainage Map
4. Hydrologic Computations
5. Hydraulic computations (**HDS #5**), including any design assumptions
6. Assessment of the problem (for culverts with known problems)
7. Alternative analysis
8. Optional Materials Evaluation

4.11.2 Bridges

Bridge hydraulic design computations and analyses shall be documented in a permanent record file. The permanent record file shall address all design standards provided herein. Documentation shall be provided in detail commensurate with the complexity of the project. Documentation shall be sufficient enough so that an independent engineer with expertise in bridge hydraulics, but not involved with the design, can fully interpret, follow and understand the logic, methods, computations, analysis and considerations used to develop the final design.

4.11.2.1 Bridges on Controlled Canals

Bridges on controlled canals not affected by hurricane surge may utilize the short format BHR located in Chapter 5 of the **Bridge Hydraulics Handbook**.

4.11.2.2 Bridge or Bridge Culvert Widening

At a minimum the documentation shall include:

1. Completed Bridge Hydraulics Recommendations Sheet (BHRS), including complete design recommendations is required for bridges, not bridge culverts. The format for the BHRS is provided in the **Plans Preparation Manual**.
2. Evidence of Field Review.
3. Hydrologic analysis including sources of data and methodology.
4. Hydraulic Computations, including any design assumptions. An electronic copy with the input and output file(s) for the final computer run should be provided.
5. Scour Analysis:
 - a) Scour Computations
 - b) Scour Protection Needs

-
6. Applicable regulatory agency documents that affect the final design. This may include documents from the Corps of Engineers, Coast Guard, water management district, DEP, etc.
 7. Deck drainage analysis and computations.

4.11.2.3 Bridge Culverts

At a minimum the documentation shall include:

1. Evidence of Field Review.
2. Hydrologic analysis including sources of data and methodology.
3. Hydraulic Computations, including any design assumptions. An electronic copy with the input and output file(s) for the final computer run should be provided.
4. Scour analysis addressing the need for inlet and/or outlet protection.
5. A summary of the alternatives considered, including cost estimates and reasons for selecting the recommended structure, and a clear explanation as to why it is the most economical structure for the site in question.
6. Applicable regulatory agency documents that affect the final design. This may include documents from the Corps of Engineers, Coast Guard, water management district, DEP, etc.
7. For Interstate system bridges over floodplains where a Regulatory Floodway has not been established, the documentation must include the evaluation required in Section 4.4 of this Chapter.

4.11.2.4 Category 1 and 2 Bridges

At a minimum the documentation shall include:

1. Completed Bridge Hydraulics Recommendations Sheet (BHRS). The format for the BHRS is provided in the *Plans Preparation Manual*.
2. Bridge Hydraulics Report including:
 - A. A summary of all design recommendations, including:
 - 1) Bridge Length, including locations (stations) of abutments.
 - 2) Channel Excavation requirements
 - 3) Minimum Vertical Clearance
 - 4) Minimum Horizontal Clearance
 - 5) Abutment type and orientation.
 - 6) Pier Orientation
 - 7) Scour Depths
 - a. Scour Design Event
 - b. Scour Check Event

-
- 8) Scour protection requirements for abutments, piers, and channel. For spill-through abutments, recommendations shall include:
 - a. Abutment Slope
 - b. Type of Protection (rubble riprap is standard)
 - c. Horizontal and Vertical Extent of Protection
 - 9) Deck drainage requirements
 - 10) Wave and surge parameters and force determination (or calculation) and analysis (for coastal bridges not elevated 1 ft. above the design wave crest elevation.)
- B. Evidence of Field Review
- C. Hydrologic analysis including sources of data and methodology.
- D. Alternative analysis or evaluation of structure sizes (length and vertical height/clearance). This evaluation shall be done consistent with Department policy for bridge hydraulic design and shall include consideration of:
- 11) Cost
 - 12) Design standards
 - 13) Structure hydraulic performance, including backwater, velocity, and scour.
 - 14) Impacts of the structure on adjacent property
 - 15) Environmental impacts
- E. The alternative analysis shall include the reasons for selecting the recommended structure, and a clear explanation as to why it is the most economical structure for the site in question. As a minimum, the following structure sizes shall be evaluated:
- 1) The minimum structure size required to meet hydraulic standards for vertical and horizontal clearance, scour, and backwater.
 - 2) Existing structure size if applicable.
 - 3) The recommended structure size if different from (1) or (2).
- F. Deck drainage analysis
- G. Supporting hydraulic computations including
- 1) Computer analysis, if appropriate, including a plan view of cross section locations and an electronic copy with the input and output file(s) for the final computer run should be provided.
 - 2) Scour computations
 - 3) Deck drainage computations
 - 4) Design assumptions
 - 5) Wave and surge parameters and force determinations and analysis (for coastal bridges not elevated 1 ft. above the design wave crest elevation.)
- H. Applicable regulatory agency documents that affect the final design.

This may include documents from the Corps of Engineers, Coast Guard, WMD, DEP, etc.

4.11.3 Document Processing

Processing of the BHR/BHRS and other supporting design documents shall be in accordance with the ***Plans Preparation Manual***.

Chapter 5

Stormwater Management

5.1 Introduction

This chapter presents standards for the design of stormwater management systems for Department projects. Guidance for drainage connection permits are covered in the ***FDOT Drainage Connection Permit Handbook***.

5.2 Regulatory Requirements

5.2.1 Chapter 14-86, Florida Administrative Code

The design of stormwater management systems for Department projects shall comply with the water quality, rate, and quantity requirements of ***Section 334.044(15), F.S., Chapter 14-86, F.A.C.***, Rules of the Department of Transportation, only in basins closed during storms up to and including the 100-year storm event, or areas subject to historical flooding.

5.2.2 Section 373.4596, Florida Statutes

Section 373.4596, Florida Statutes requires the Department of Transportation to fully comply with state, water management district and, when delegated by the State, local government stormwater management programs.

5.2.3 Chapter 62-25, Florida Administrative Code

Chapter 62-25, F.A.C., rules of the Florida Department of Environmental Protection specifies minimum water quality treatment standards for new development.

5.2.4 Chapter 62-40, Florida Administrative Code

Chapter 62-40, F.A.C., rules of the Florida Department of Environmental Protection outlines basic goals and requirements for surface water protection and management to be implemented and enforced by the Florida Department of Environmental Protection and Water Management Districts.

5.2.5 National Pollutant Discharge Elimination System

The *National Pollutant Discharge Elimination System (NPDES) permit program* is administered by the U. S. Environmental Protection Agency. This program requires permits for stormwater discharges into waters of the United States from industrial activities; and from large and medium municipal separate stormwater systems.

5.3 Environmental Look Arouds (ELA)

After project stormwater management requirements are determined and before stormwater management design decisions are planned, convene a meeting with regional stakeholders to explore watershed wide stormwater needs and alternative permitting approaches. The following opportunities should be evaluated for application on the project:

1. WMD / DEP issues: wetland rehydration, water supply needs, minimum flows and levels, flooding, TMDL needs, acquisition of fill from DEP/WMD lands, etc.
2. City / County issues: stormwater re-use, flooding, discharge to golf courses or parks, NPDES needs, water supply needs
3. DOT project permitting: regional treatment, stormwater re-use, joint use facilities

Appropriate personnel are as follows:

WMD / Regional DEP: ERP, water quality, water supply, wetland, and MFL personnel, BMAP coordinator(s)

DOT: DDrE, PD&E Planning, or Design PMs, Permit coordinator, NPDES representative

City / County: (as decided by the city/county) City Engineer, Public Works Director, Stormwater Engineer

Areas of potential cooperation shall be documented in the project reports for future follow up as the design moves forward.

The best time for holding these ELA meetings is before identification of right-of-way acquisition in the PD&E phase. If no right-of-way acquisition or PD&E phase is scheduled, then target early as feasible within the design phase.

5.4 Design Standards

5.4.1 Design of Systems

5.4.1.1 General

Design stormwater management facilities to provide the necessary quantity, rate, and quality control based on the presumption that for the existing discharge all necessary quantity, rate, and quality control of stormwater from upper property has occurred prior to reaching the right-of-way.

For facilities designed to be dry, or using underdrains, or exfiltration, provide the appropriate geotechnical analysis, certified by the project Geotechnical Engineer.

If economically prudent, offsite discharges may be accepted (co-mingled) into the Department's wet detention facilities without increasing the required water quality treatment design; in such cases, hydraulic impacts on upstream property owners must be avoided.

Accommodate all offsite runoff in accordance with Department's criteria and all regulatory agency criteria. Maintain all historical flow patterns for offsite flows. For co-mingling offsite discharges into the Department's dry retention facilities, consult the District Drainage Engineer for direction on whether offsite inflows should be co-mingled or bypassed.

Modification for Non-conventional Projects:
--

Delete the previous paragraph and see the RFP for requirements.

Stormwater pond control structures shall consist of ditch bottom inlets in conjunction with outfall pipes. Do not use trapezoidal weirs, shaped into the pond berm, as primary control structures except where inlets and pipes are not feasible.

Start initial pond routing at the control elevation unless otherwise required by the Water Management District permit.

No component of a permanent stormwater system will be controlled by a pump or any other mechanical means.

With facilities designed to be wet, provide a minimum permanent pool depth of 6 feet to minimize aquatic growth.

Adjust the tailwater elevation for coastal pond outfalls to account for sea level rise using the methodology in Section 3.4.1.

5.4.1.2 Watersheds with Positive Outlets

Projects discharging to offsite areas subject to reported historical flooding, up to the 100-year, 24-hour storm event, shall comply with the discharge requirements of **Rule 14-86 FAC**. Additionally, any Department projects discharging into drainage systems with heightened public safety risks, such as roadway drainage systems, shall comply with **Rule 14-86 FAC**.

5.4.1.3 Watersheds without Positive Outlets

For projects that are located within a watershed that contributes to a depressed low area, or a lake that does not have a positive outlet such as a river or stream to provide relief (i.e., closed basin or isolated depression), a detention/retention system is required.

The detention/retention system shall comply with the discharge requirements of **Rule 14-86 FAC**. The retention volume should recover at a rate such that one-half of the volume is available in 7 days with the total volume available in 30 days, with a sufficient amount recovered within the time necessary to satisfy applicable water quality treatment requirements.

5.4.1.4 Exceptions

5.4.1.4.1 Tidal Areas

Water quantity and rate control criteria are not applicable for projects which discharge directly into tidal areas. This is subject to permission of the appropriate permitting authority.

5.4.1.4.2 Downstream Improvement

Water quantity and rate control criteria are not applicable where it can be demonstrated that downstream conveyance and storage systems have adequate capacity, or will be improved to have adequate capacity for the increased quantity and rate of runoff created by the project. This is subject to permission of the downstream property owner(s), and the appropriate permitting authority.

5.4.1.4.3 Compensatory Treatment

For projects where available right-of-way is insufficient and cannot be feasibly obtained for proper treatment (volume, rate, quality), treatment of existing untreated offsite areas which discharge to the same receiving water body may be substituted in lieu of treating the project. This is subject to permission of the property owner downstream of the

untreated project area, and the appropriate permitting authority.

5.4.1.4.4 Permission from the Downstream Property Owner

Water quantity and rate control criteria can be waived when the downstream property owner(s) agrees to accept the increased quantity and rate of runoff created by the project. This approach is subject to appropriate exemption by the permitting authority.

5.4.1.5 Aviation

When designing stormwater facilities within five miles of airports, coordinate with the District Aviation Administrator to determine if stormwater facilities are within Federal Aviation Administration (FAA) oversight. If ponds are within FAA oversight and cannot be prudently moved, these facilities must be designed using FAA guidelines. These FAA design guidelines are intended to reduce plane bird strikes by making stormwater facilities less attractive to birds.

5.4.2 Hydrologic Methods

The hydrologic method used shall be one of the following:

1. Modified Rational for basins having a time of concentration of 15 minutes or less.
2. SCS Unit Hydrograph Method

5.4.3 Protective Treatment

Stormwater management facilities shall be designed with due consideration of the need for protective treatment to prevent hazards to persons. General guidance on protective treatment is provided in **Section 3.7**. Flat slopes shall be used when practical. Retention areas shall only be fenced in accordance with **Section 5.4.4.2 (4)**.

5.4.4 Construction and Maintenance Considerations

5.4.4.1 General

The design of stormwater management systems shall be consistent with the standard construction and maintenance practices of the Department. Standard details for inlets manholes and junction boxes, end treatments, and other miscellaneous drainage details are provided in the standard index drawings. Specifications are provided in the **Standard Specifications for Road and Bridge Construction**. In the event standard index

drawings are not suitable for a specific project need, a detailed design shall be developed and included in the plans; and, as appropriate, special provisions shall be provided for inclusion with the project specifications. Proper design shall also consider maintenance concerns of adequate physical access for cleaning and repair.

5.4.4.2 Detention and Retention Ponds

The design of stormwater management facilities shall be consistent with the Highway Beautification Policy and integrated with existing and proposed landscaping, and adjoining land uses. Naturalistic and curvilinear shapes, landscape shelves, tree plantings, selective clearing, and other aesthetic improvements shall be designed by an interdisciplinary team consisting of the Landscape Architect, Drainage Engineer, and local maintenance office. The pond aesthetics design approach shall be developed early enough within the project production schedule to be included in the determination of pond right-of-way acquisition needs.

Standard design features for detention and retention ponds are shown in **Figure 5.1** and are as follows:

1. Maintenance Berm:

Ponds shall be designed to provide a minimum 20 feet of horizontal clearance between the top edge of the control elevation and the right-of-way line. At least 15 feet adjacent to the pond shall be at a slope of 1:8 or flatter. The inside edge of the maintenance berm shall employ a minimum radius of 30 feet, and be a minimum of 1 ft. above the maximum design stage elevation. The berm area shall be sodded. Discuss maintenance needs with the Department before acquiring additional R/W to construct maintenance access around the full perimeter.

2. Slopes:

For facilities designed to be wet, sod pond slopes to the control elevation of the pond. For facilities designed to be dry, sod pond slopes to the bottom of the slope.

3. Freeboard:

As a safety factor for hydrologic inaccuracies, grading irregularities, control structure clogging, and downstream stage uncertainties, at least 1 foot of freeboard is required above the maximum design stage of the pond. The freeboard is the vertical distance between the maximum design stage elevation of the pond and the inside edge of the berm as illustrated in **Figure 5-1**.

For linear treatment swales, the minimum freeboard is 0.5 ft.

4. Fencing:

Fences shall be installed around ponds only when a documented maintenance need for restricted access has been demonstrated. The installation of fencing

around stormwater ponds requires a Design Variation approved by the State Roadway Design Engineer. Where approved, fences selected should be context sensitive, and not detract from the appearance of the ponds or adjoining property.

When requesting the approval of a Design Variation to install fence around stormwater management facilities, the conditions below, when properly documented, are typically acceptable justifications for ponds designed to be permanently wet (permanent design water depth of 2 ft. or greater):

- Above water pond slopes steeper than 1:4 are unavoidable. Note: Stormwater permits typically require wet ponds to be fenced when the above water slopes of the pond are steeper than 1:4. Ponds that enjoy the benefit of fence at the right-of-way line need no additional fencing around them.
- A hidden hazard occurs within 5 ft. of the water's edge. Examples of a hidden hazard are a sharp drop off, such as a 1:2 slope, sharp objects, or otherwise potentially injurious, hidden, underwater hazards.
- The site is likely to experience significant exposure to children or the elderly. Examples of such locations are ponds immediately adjacent to schools, daycares, assisted living facilities, nursing homes, public playgrounds, public basketball courts, etc.

In addition, when requesting the approval of a Design Variation to install fence around ponds of any water depth, the conditions below, when properly documented, are typically acceptable justifications:

- Livestock are expected to wander into the stormwater management facility
- Illicit dumping has historically occurred or is expected to occur

5. Access Easements:

When pond areas are not accessible directly from the road right-of-way, an access easement shall be provided.

6. Seepage:

When diking or berming a stormwater pond above surrounding grade, consider seeping and piping and consult geotechnical expertise for the stability of the earthwork berm. Avoid planting woody species with developed root structures on embankment berms, as this can cause piping and geotechnical failures.

7. Traversable Pond Overflow:

Design and construct all berm style weirs in pond or swale berms to be traversable. Berm style weirs require a structural and geotechnical design to support the loading of maintenance vehicles without failure.

Modification for Non-conventional Projects:
--

Do not use any proposed berm style weirs, trapezoidal or otherwise, unless explicitly allowed in the RFP.

5.5 Documentation

The documentation for stormwater management facilities shall be sufficient to justify the facility, and describe the design and operation. At a minimum the documentation shall include:

1. Pond Siting Evaluation (required only if additional right of way is obtained for the pond) consisting of:
 - a. Identification of alternate sites.
 - b. For each alternate include preliminary information about:
 - i. Right of way costs.
 - ii. Water quality and quantity volumes.
 - iii. Soil and groundwater conditions.
 - iv. Potential hazardous waste contaminations.
 - v. Potential impacts to endangered species.
 - vi. Potential impacts to cultural resources.
 - vii. Potential impacts to utilities.
 - viii. Potential impacts to existing landscapes and adjoining land uses.
2. Drainage Map.
3. Evidence of field review.
4. Description of applicable regulatory requirements.
5. Description of pre-developed runoff characteristics such as basin boundaries, outfall locations, peak runoff rates, and methods of conveyance.
6. Description of post-developed runoff characteristics such as those listed in item five.
7. Schematic of interconnected ponds (if applicable).
8. Description of the operation of the facility. This will be used by design reviewers, but is intended for maintenance personnel who may have to certify that the facility is operating as designed.
9. Soils and groundwater information.
10. Stage versus storage values.
11. Electronic file of routing calculations.
12. Any special maintenance requirements.
13. Justification for any proposed fencing.
14. Documentation of ELA efforts and results.

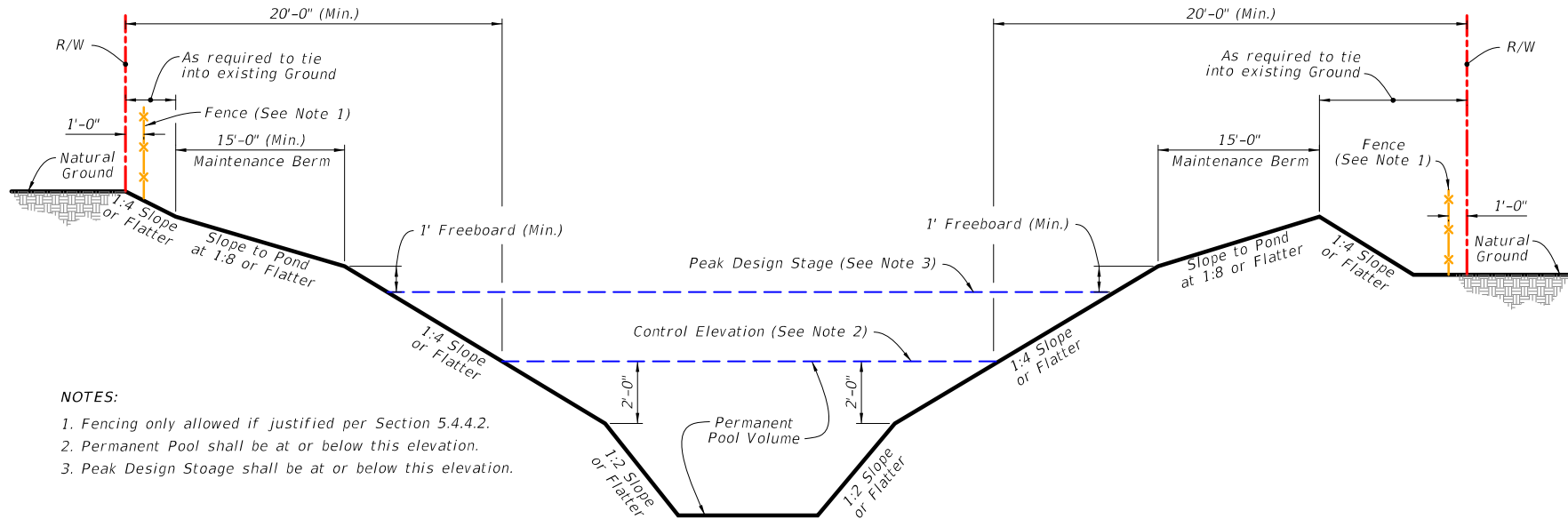

Figure 5-1
Minimum Clearance
Retention-Detention Ponds

Chapter 6

Optional Culvert Materials

6.1 Introduction

Optional culvert materials shall be considered for all culvert applications including, but not limited to, storm drains, cross drains, side drains, gutter drains, vertical drains, and French drains. All culvert materials shown in **Table 6-1** for the application being designed shall be evaluated. The evaluation shall consider functionally equivalent performance in three areas: durability, structural capacity, hydraulic capacity.

6.2 Durability

Culverts shall be designed for a design service life (DSL) appropriate for the culvert function and highway type. Department requirements for DSL are provided in **Table 6-1**. The projected service life of pipe material options called for in the plans shall provide, as a minimum, the Design Service Life. Pipe material standards shall not be reduced when projected service life exceeds design service life.

In estimating the projected service life of a material, consideration shall be given to actual performance of the material in nearby similar environmental conditions, its theoretical corrosion rate, the potential for abrasion, and other appropriate site factors. Theoretical corrosion rates shall be based on the environmental conditions of both the soil and water. As a minimum the following corrosion indicators shall be considered:

1. pH
2. Resistivity
3. Sulfates
4. Chlorides

Tests for the above characteristics shall be based on FDOT approved test procedures. For projects with a small amount of pipe, to avoid unnecessary site specific testing, generalized soil maps may be used to delete unsuitable materials from consideration. When known, the potential for future land use changes which may change soil and water corrosion indicators shall also be considered.

6.2.1 Culvert Service Life Estimation

The computer program, Tables and Figures (found in **Appendix B** of the **Optional Pipe Handbook**), and/or criteria stated below should be used in evaluating the estimated service life for the following culvert materials:

The Culvert Service Life Estimator Program can be found here: [Drainage Design Aids](#)

Galvanized Steel:	Figure 6-1 and Table 6.2
Aluminized Steel:	Figure 6-2 and Table 6.3
Aluminum:	Figure 6-3 and Table 6.4
Reinforced Concrete:	Figure 6-4 and Table 6.5
Non-reinforced Concrete:	100 Years (pH \geq 4.0)
HDPE Class-II:	100 Years
HDPE Class-I:	50 Years
Polypropylene (PP)	100 Years
Steel Reinforced Polyethylene (SRPE)	100 Year
F949 PVC	100 Years
Other Polyvinyl Chloride:	50 Years

Note: Estimated Service Life for metal pipe may be increased by 10 years, if it is coated with a bituminous coating.

6.3 Structural Evaluation

Appendix C provides minimum and maximum cover requirements. The minimum thickness established to meet Durability requirements shall be evaluated to assure structural adequacy and increased if necessary. Materials and sizes not listed in **Appendix C** shall be evaluated using the guidelines found within the **AASHTO LRFD Design Manual** and industry recommendations, and modified as necessary to be consistent with **Appendix C** and any applicable specifications and installation procedures.

6.4 Hydraulic Evaluations

The hydraulic evaluation shall establish the hydraulic size in accordance with the design standards provided in the **Drainage Manual** for the particular culvert application. For storm drains and cross drains, the design shall use the Manning's roughness coefficient associated with concrete pipe, spiral rib pipe, polyethylene pipe and polyvinyl chloride pipe.

For side drains, the hydraulic design shall use a one-size design. If a material type is considered to be inappropriate, it must be eliminated as an option in the plans.

In addition, the hydraulic evaluation shall verify that the standard joint performance as required by the **Standard Specifications**, Section 430-4.1 will be sufficient. For situations where the minimum joint performance as required by the **Standard Specifications** is not sufficient, special provisions to specify the proper joint shall be provided in the plans. For example, a pump station with a small diameter pressurized storm drain should use a High Pressure joint. (Note: Joints are tested and rated by the State Materials Office.)

6.5 Culvert Material Types

The types of culvert materials to be considered for the various culvert applications are as follows. Other materials may be considered, but are not required to be.

Extensions of existing culverts (side drains, storm drains and cross drains) shall be made with the existing pipe material. In the event that the existing pipe material is no longer produced, use the most similar material available, i.e. extend fiber reinforced concrete pipe with concrete pipe (RCP or NRCP).

Application	Materials to be Considered
Cross Drain French Drain Side Drain Storm Drain	Aluminized Steel Aluminum Concrete (all approved types) Corrugated Polyethylene (60" maximum) Steel Reinforced Polyethylene (60" Maximum) Polyvinyl Chloride (42" maximum) Polypropylene (60" maximum) Galvanized Steel
Gutter Drain	Corrugated Aluminized Steel (n > 0.020) Corrugated Aluminum (n > 0.020) Corrugated Steel (n > 0.020)
Vertical Drain	Ductile Iron (In saline environments, consider fiberglass reinforced pipe with welded joints, F949 PVC, and steel pipe)
Wall Zone Pipes	Polyvinyl Chloride (42" maximum) Polypropylene (60" maximum) Steel

The **Plans Preparation Manual** illustrates a method of presenting the acceptable pipe

materials in the plans. The acceptable pipe materials for side drains, storm drains, and cross drains must be presented in the plans.

6.6 Jack and Bore

When drainage structures are installed using jack and bore, the casing shall be used as the carrier pipe except under railroads or in higher pressure designs. Information on calculating pipe thickness for corrosion resistance can be found in the ***Culvert Service Life Estimator*** (2013 version or later) and in the ***Optional Pipe Handbook***.

6.7 Documentation

The documentation shall be sufficient to justify eliminating material types from being acceptable and shall include at a minimum the following:

1. Design Service Life required.
2. Soil and water corrosion indicators used in estimating service life.
3. Estimates of service life at cross drains and at various locations of storm drain systems.
4. Structural Evaluation (comparison of maximum and minimum cover heights to actual cover height).

Modification for Non-conventional Projects:
The above documentation in Section 6.7 shall be required only for the pipe materials selected for use. Selected material shall be documented on one of the following: Summary of Drainage Structures Sheets, Optional Materials Sheet, or the as-built plan view.

TABLE 6-1 CULVERT MATERIAL APPLICATIONS AND DESIGN SERVICE LIFE

Application		Storm Drain		Cross Drain		Side Drain ⁴	Gutter Drain	Vertical Drain ¹⁰	Wall Zone Pipe ¹¹	French Drain			
		Minor	Major	Minor	Major	All	All	All	All	Replacement will Impact the Roadway ⁵		Other	
Design Service Life →		50	100	50	100	25	25 ⁶	100	100	50	100	50	
Culvert Material		An * indicates suitable for further evaluation											
P I P E	Corrugated Aluminum Pipe CAP	*	*	*	*	*	*			*	*	*	
	Corrugated Steel Pipe CSP	*	*	*	*	*	*			*	*	*	
	Corrugated Aluminized Steel Pipe CASP	*	*	*	*	*	*			*	*	*	
	Spiral Rib Aluminum Pipe SRAP	*	*	*	*	*				*	*	*	
	Spiral Rib Steel Pipe SRSP	*	*	*	*	*				*	*	*	
	Spiral Rib Aluminized Steel Pipe SRASP	*	*	*	*	*				*	*	*	
	Steel Reinforced Concrete Pipe RCP	*	*	*	*	*				*	*	*	
	Non-reinforced Concrete Pipe NRCP	*	*	*	*	*				*	*	*	
	Polyethylene Pipe – Class I HDPE-I	*		*		*				*		*	
	Polyethylene Pipe – Class II ⁸ HDPE-II	*	*	*	*	*				*		*	
	Polypropylene Pipe PP	*	*	*	*	*			*	*	*	*	
	Steel Reinforced Polyethylene Pipe SRPE	*	*	*	*	*							
	Polyvinyl-Chloride Pipe ⁷ PVC	*	F949	*	F949	*			F949	*	*	F949	*
	Fiberglass Pipe								*				
	Steel pipe (per Spec 556-2.1)								*	*			
	Ductile Iron Pipe (per Spec 556-2)								*				
S T R P L	Structural Plate Aluminum Pipe SPAP	*	*	*	*	*							
	Structural Plate Alum. Pipe-Arc SPAPA	*	*	*	*	*							
	Structural Plate Steel Pipe SPSP	*	*	*	*	*							
	Structural Plate Steel Pipe-Arch SPSPA	*	*	*	*	*							
B O X	Aluminum Box Culvert	*	*	*	*	*							
	Concrete Box Culvert CBC	*	*	*	*	*							
	Steel Box Culvert	*	*	*	*	*							

Table notes are on the following page

Notes for Table 6-1

1. A minor facility is permanent construction such as minor collectors, local streets and highways, and driveways, provided culvert cover is less than 10 feet. Additionally, this category may be called for at the discretion of the District Drainage Engineer where pipe replacement is expected within 50 years or where future replacement of the pipe is not expected to impact traffic or require extraordinary measures such as sheet piling.
2. A major facility is any permanent construction of urban and suburban typical sections and limited access facilities. Urban facilities include any typical section with a fixed roadside traffic barrier such as curb or barrier wall. Additionally, rural typical sections with greater than 1600 AADT are also included in this category.
3. Temporary construction normally requires a much shorter design service life than permanent does. However, temporary measures that will be incorporated as permanent facilities should be treated as permanent construction with regard to design service life determination.
4. Although culverts under intersecting streets (crossroads) function as side drains for the project under consideration, these culverts shall be designed using applicable cross drain service life criteria, not the shorter sidedrain service life criteria. Index 273 shall be used for end treatment.
5. Replacing this pipe would require removal and replacement of the project's pavement or curb.
6. Gutter drains under retaining or through walls should use a 100 year DSL.
7. F949 PVC service life is 100 years. Other PVC pipe has a 50 year service life. PVC pipe should not be used in direct sunlight unless it meets the requirements of **Specification 948-1.1**.
8. Class II HDPE pipe may not be used in the Florida Keys.
9. Any pipes under or adjacent to permanent structures such as retaining walls, MSE walls, buildings, etc. shall use a 100 year DSL.
10. Resilient connectors required for all vertical pipes.
11. Due to the expected high cost of steel pipe, only list steel pipe as an option if no other pipe material is allowed.

Appendix A

Drainage Law

APPENDIX A

DRAINAGE LAW74

A.1 OVERVIEW

Current drainage law has evolved from case law in the courts, administrative hearing rulings, and the requirements which have been placed on the Department by other regulatory agencies. The discussion presented in this chapter of the Department's legal rights and responsibilities to the public as they relate to highway drainage is not intended as a substitute for legal counsel, but rather to familiarize engineers with basic drainage law, terminology, rules, and applications as they relate to state road design and maintenance.

A.2 TERMINOLOGY

Applicable Standards or Applicable water Quality Standards or Minimum Design and Performance Standards: Those discharge standards of the appropriate regulatory entity which apply to the facility under consideration.

Approved Stormwater Management Plan or Master Drainage Plan: A regional plan adopted or approved by a city, county, Water Management District, or other agency with specific drainage or stormwater management authority; provided that (a) such plan is actively being implemented; (b) any required construction is substantially complete; (c) downstream mitigative measures have been provided for in the plan; and (d) that the use of any Department facilities either existing or planned, which are part of such plan have been agreed to by the Department.

Artesian Waters: Percolating waters confined below impermeable formations with sufficient pressure to spring or well up to the surface.

Backwater: An unnaturally high stage in a stream caused by obstruction or confinement of flow, as by a dam, a bridge, or a levee. Its measure is the excess of unnatural over natural stage, not the difference in stage upstream and downstream from its cause.

Concentration: The unnatural collection or convergence of waters, discharging in a narrower width and at a greater depth or velocity.

Critical Duration: The length of time of a specific storm frequency which creates the largest volume or highest rate of net stormwater runoff (post-improvement runoff less pre-improvement runoff) for typical durations up through and including the 10-day duration for closed basins and up through the 3-day duration for basins with positive outlets. The critical duration for a given storm frequency is determined by calculating the peak rate and volume of stormwater runoff for various storm durations and then comparing the pre-

improvement and post-improvement conditions for each of the storm durations. The duration resulting in the highest peak rate or largest net total stormwater volume is the “critical duration” storm (volume is not applicable for basins with positive outlets).

Diversion: (1) The taking of water from a stream for a beneficial purpose (irrigation, water supply, power, etc.) even though a portion may return to the same stream. (2) The deflection of surface waters or stream waters so that they discharge into a watercourse to which they are not naturally tributary. Deflection of flood water is not diversion.

Drainage Connection: Any structure, pipe, culvert, device, paved or unpaved area, swale, ditch, canal, or any other appurtenance or feature, whether naturally occurring or created, which is used or functions as a link to convey stormwater.

Easement: The right to use the land of others. It may derive from the common law or be acquired, usually by purchase or condemnation, but occasionally by prescription or inverse condemnation. The right is not exclusive, but subject to rights of others in the same land, the lesser right being servient to a prior dominant right. Easements for drainage may give rights to impound, divert, discharge, concentrate, extend pipelines, deposit silt, erode, scour, or to perform any other necessary activity of a highway development.

Use of land of others without right usually leads to right in the future. If use is adverse and notorious for a statutory period, an easement is acquired by prescription with compensation, but, at any earlier time, the owner of the other land may sue for compensation by inverse condemnation.

Erosion and Accretion: Loss and gain of land, respectively, by the gradual action of a stream in shifting its channel by cutting one bank while it builds on the opposite bank. Property is lost by erosion and gained by accretion, but not by avulsion, when the shift from one channel to another is sudden. Property is gained by reliction when the water in an ocean, lake, river, or stream recedes.

Engineer: A Professional Engineer registered in Florida pursuant to the provisions of Chapter 471, **Florida Statutes**, who as appropriate is competent in the fields of hydraulics, hydrology, stormwater management or stormwater pollution control.

Erosion and Scour: The cutting or wearing away by the force of water of the banks and bed of a channel in horizontal and vertical directions, respectively.

Facility: Anything built, installed, or maintained by the Department within the Department’s right of way.

Flood Waters: Former stream waters which have escaped from a watercourse (and it’s overflow channel) and flow or stand over adjoining lands. Flood waters remain as such

until they disappear by infiltration, evaporation, or return to a natural watercourse; they do not become surface waters by mingling with such waters or stream waters by eroding a temporary channel.

Groundwater: Water situated below the surface of the land, irrespective of its source and transient status. Subterranean streams are flows of groundwater parallel to and adjoining stream waters, and are usually determined to be integral parts of the visible streams.

Impervious Areas: Surfaces which do not allow, or minimally allow, the penetration of water. Examples of impervious areas are building roofs, all concrete and asphalt pavements, compacted traffic-bearing areas such as limerock roadways, lakes, wet ponds, pond liners, and other standing water areas, including some retention/detention areas.

Improvement: Any manmade change to property from previously existing conditions.

Marshes: Lands saturated by waters flowing over the surface in excess of infiltration capacity, such as sloughs or rivers and tidal channels.

Navigable Waters: Those stream waters lawfully declared or actually used as such.

Navigable Waters of the United States: Those bodies of water determined by the Chief of the U. S. Army Corps of Engineers to be so used in interstate or international commerce. Other streams have been ruled navigable by courts under the common law that navigability in fact is navigability in law.

Owner: Any owner of land, usually specified in relation to another owner. Of two owners affected by the flow of water, the one upland is the upper owner and the other the lower owner. The highway has an owner with the same rights in common law as private owners.

Peak Discharge: The maximum flow of water passing the point of interest during or after a rainfall event.

Perched Waters: Percolating waters detained or retained above an impermeable formation, standing above and detached from the main body of groundwater.

Percolating Waters: Those which have infiltrated the surface of the land and moved slowly downward and outward through devious channels (aquifers) unrelated to stream waters, until they either reach an underground lake or regain and spring from the land surface at a lower point.

Positive Outlet: A point of stormwater runoff into surface waters which under normal conditions would drain by gravity through surface waters ultimately to the Gulf of Mexico, or the Atlantic Ocean, or into sinks, closed lakes, or recharge wells provided the receiving

waterbody has been identified by the appropriate Water Management District as functioning as if it recovered from runoff by means other than transpiration, evaporation, percolation, or infiltration.

Pre-improvement: The condition of property before an improvement is made or, in regard to **Rule 14-86, F.A.C.**, The condition of property (a) Before November 12, 1986; or (b) On or after November 12, 1986, with connections which have been permitted under **Rule 14-86, F.A.C.** or permitted by another governmental entity based on stormwater management requirements equal to or more stringent than those in **Rule 14-86, F.A.C.**

Stormwater: The flow of water that results from and occurs immediately following a rainfall event.

Stream Waters: Former surface waters that have entered and now flow in a well-defined natural watercourse together with other waters reaching the stream by direct precipitation or from springs in the bed or banks of a watercourse. They continue as stream waters as long as they flow in the watercourse, including in overflow and multiple channels as well as the ordinary or low water channel.

Surface Water: Water upon the surface of the earth, whether contained in natural or artificial boundaries or diffused. Water from natural springs shall be classified as surface water when it exits onto the earth's surface.

Swamps: Lands saturated by groundwater standing at or near the surface.

Volume: The total amount of water coming to a point of interest. It may be from surface water, watercourses, groundwater, or direct precipitation.

Watercourse: A definite channel with bed and banks within which water flows, either continuously or in season. A watercourse is continuous in the direction of flow and may extend laterally beyond the definite banks to include overflow channels contiguous to the ordinary channel. The term does not include artificial channels such as canals and drains, except as natural channels are lawfully trained or restrained by the works of man. It also does not include depressions or swales through which surface or errant waters pass.

Watershed: The region draining or contributing water to a common outlet, such as a stream, lake, or other receiving area.

A.3 SURFACE WATER LAW

A.3.1 UPLAND OWNER

Generally, an upland owner has an easement over the land of the lower land owner for surface waters that flow over the lower land. In exchange for this privilege, the upland owner has the duty not to divert surface waters, change the velocity of flow, add to the pollution, or increase the amount of waters from other directions to the extent that damage occurs on the lower lying property of the other land owner. Ideally, the surface-water flow should imitate the conditions in existence when the lands were in a natural state. Realistically, changes made in the development of real property are reviewed by the courts on a case-by-case basis to determine whether the changes which occur are substantial and whether the development has been reasonable. A major factor, if the courts find that a nuisance has been created by the upland owner on the lower land, is whether or not the lower land owner came to the nuisance.

A.3.2 LOWER LAND OWNER

Generally, the lower land owner has the duty to the upland owner not to prevent or obstruct the flow of surface waters onto his land from that of the upland owner. The lower land owner cannot exclude these surface waters, nor can he cause the water to flow back to his upland neighbor. One exception to this rule is when such a backflow is a natural condition which could be anticipated from the natural configurations of the land. An example of this exception would be a land-locked storage basin that overflows in an intense storm of long duration. Even if it is foreseeable, the overflow onto the neighboring land when caused by natural conditions is not a trespass by the lower land owner. However, if the lower land owner diverted additional waters into the land-locked basin, and took the chance that such a natural event could occur, the lower land owner may be responsible for the surface-water overflow onto the neighboring property.

Another exception to the responsibilities owed to the lower land owner can be found in the low lying areas in South Florida where indiscriminate rim ditching was allowed. If the lower land owner came to this condition, he cannot assert a trespass or nuisance claim.

If the Department is involved in any way, on any side of the mentioned situations, contact with the legal department is required.

If a lower land owner accepts surface water from the upland owner over and above the natural surface water, and the upland owner developed property in reliance on that acceptance, the lower land owner may be prevented from refusing to accept that water volume in the future. An example of this would be an owner of a cow pasture who accepts Department highway drainage into a pond on his land for use as a drinking area for his herd of cows. If he or a subsequent owner later decided to build a shopping center by the state roadway, he would continue to be responsible for the storage of the water placed on his property by the Department.

A.3.3 STATUS QUO AND REASONABLY FORESEEABLE DEVELOPMENT

Two important items in highway drainage design for the Department to review from a legal perspective are the current natural state of the adjoining property to the highway and the reasonably foreseeable development that will occur in the area. The first concern may be addressed by creating current and/or reviewing historical drainage maps of the area. The second concern may be evaluated by reviewing local comprehensive zoning and stormwater management plans for the area in question. When feasible, the highway system design should be integrated with the local plans.

A.3.4 SUMMARIES OF CURRENT FLORIDA CASE LAW

The following summaries of the leading Florida cases on surface-water management should assist the drainage engineer in his review of problematic drainage areas:

In Koger Properties, Inc. v. Allen, 314 So.2d 792 (Fla. 1st DCA 1984), a developer had improved its property by constructing office buildings and parking areas, which gathered rainfall that had been previously absorbed by the earth and channeled it through storm drains that terminated at an opening directly in front of the lower land owner's (the plaintiff) property. The developer agreed that it would pipe the water through a 36-inch pipe under the road owned by the City of Tallahassee in front of the plaintiff's property, and the City agreed to carry the water from that point through a ditch which it agreed to enlarge.

The developer went ahead with construction without keeping the City advised of its progress, so that the City was unaware as to when it needed to improve its facilities.

Stormwater from a subsequent rainfall event was projected with great force from the terminus of the developer's storm drainage system at a point directly across the road from the plaintiff's home. The water overflowed the ditch, ran across the road in a small river, and flooded the plaintiff's property, causing great damage to his home.

A jury awarded the plaintiff compensatory and punitive damages against the developer for knowingly flooding the plaintiff's property. The jury found that the City was not responsible for any of the damages suffered by the plaintiff.

In Leon County v. Smith, 397 So.2d 362 (Fla. 1st DCA 1980), a developer of a subdivision designed a drainage system that would collect surface water and transport it east to west to a central ditch and then southerly through a ditch to the plaintiff/land owner's property. The outfall point for this water was along the northern boundary line of the land owner's property and no provisions were made for transporting the water across his land.

Later, the County accepted ownership of and responsibility for the drainage system. As homes were built in the subdivision, increasing amounts of stormwater entered the drainage system and discharged onto the plaintiff's property. The County then enclosed

portions of the drainage system with pipes, and other drainage systems were connected to it. The velocity of the water flow was so increased by these actions that the drainage carved gullies 4 to 6 feet deep into the plaintiff's land. In addition, water continued flowing from the subdivision for days after the rain stopped and the area in and around the ditches remained a muddy ooze. Eventually, the flooding rendered the plaintiff's land useless.

The court held that, as a result of the County's action, the County had taken the plaintiff's property and was required to pay him just compensation for that property.

In Hanes v. Silgain, 448 So.2d 1130 (Fla. 1st DCA 1984), the plaintiff Hanes alleged that the manner in which Silgain Motel Corporation and Gulf Oil Corporation developed their property unreasonably diverted the natural flow of surface water to the detriment of the Hanes' property. Hanes further alleged that Silgain was negligent in designing and constructing an inadequate retention basin. Silgain then brought a third party action against the Department of Transportation alleging, among other things, that the Department negligently maintained a storm drainage system in such a manner as to wrongfully divert and disperse large volumes of surface waters onto Silgain's land in a concentrated stream.

The Department in turn brought a third party action seeking contribution against various land owners and users, asserting that the defendants developed their property in a manner that diverted and cast unreasonable quantities of surface water into the Department storm drainage system. The Department also alleged that such diversion overtaxed its drainage system, thereby rendering the defendants proportionately responsible for such damage as may have resulted to Silgain and Hanes from any excess drainage system discharge.

The Department's complaint was dismissed with prejudice. The appellate court upheld this dismissal, ruling that the Department was solely responsible for the maintenance of its drainage system and that commercial developments draining into this system did not jointly share in this responsibility.

In Department of Transportation v. Burnette, 384 So.2d 916 (Fla. 1st DCA 1980), the Department was enjoined from collecting water in pipes and ditches, and from diverting the water from its natural course and sending it onto Burnette's property.

The court found that the natural drainage path for land immediately surrounding U.S. 90 within a half mile west of Madison was northward under the highway and across property later occupied by North Florida Junior College. A culvert system was installed on the highway. Subsequently, those northward drainage courses were plugged, apparently to protect North Florida Junior College. This action caused ponding immediately south of the highway.

Then, in 1969, the Department allegedly changed the drainage by constructing and buying a ditch on an easement from the highway 500 feet south toward the northern boundary of the subject property. During the same project, the Department added more

drainage to this system through a culvert along the south side of State Road 10, adding the runoff from 103 acres of improved land in municipal Madison. Burnette's engineer testified that an estimated 14 million gallons (43 acre-ft) of water from the City of Madison would be included in the drainage system and that under such conditions, 50 low acres of Burnette's land would be flooded and access would be limited on the remaining 50 acres.

The court concluded, however, that an action for inverse condemnation did not lie, because all beneficial uses to the property were not deprived and because the property had always been subject to intermittent flooding.

Stoer v. Ocala Mfg. Ice and Packing Co., 24 So.2d 579 (Fla. 1946), created an exception to upland owner liability in Florida in situations where the upland owner drains water into a natural watercourse. In such cases, an upland owner can increase the volume and velocity of the water flow into a natural watercourse without incurring any liability as long as the natural flow of water is not diverted or the watercourse is not overtaxed to the injury of the lower land owners.

A.4 POLLUTION CONTROL

Pollution control is becoming increasingly important in drainage law. The engineer faces a potential legal problem with environmental consequences at practically every point on a highway. There are three primary areas of highway drainage in which the Department must be especially concerned with regulation and liability:

- Dredge and fill
- Stormwater runoff
- Underground injection wells

The following is a general discussion of regulated activities that require permits from various agencies. It is not intended to be project- specific. Design permit assistance for a particular project should be obtained from the Bureau of Environment and the permit coordinator for the project.

The Department of Environmental Protection (DEP) is the chief pollution control agency in the state. Their jurisdiction over water pollution control extends to "waters of the state" as defined in Section 403.031, **Florida Statutes**:

"Rivers, lakes, streams, springs, impoundments, and all waters or bodies of water including fresh, brackish, saline, tidal surface, or underground."

It is not necessary for the area included in the waters of the state to be perpetually submerged in water; the DEP includes in its jurisdiction landward areas which are only covered by water some of the time. The boundaries of these areas are defined by the presence of plant species currently listed in **Rule 17-4.02, FAC**.

A.4.1 DREDGE AND FILL

All dredge and fill activities conducted in areas either in or connected to waters of the state are required to comply with water quality standards specified in **Rule 17-3, FAC**. The standards establish criteria that define the maximum level of listed pollutants allowable in a water body, determined by the water use classification for that body. Five levels of classification are used to delineate water use. For example, the Fenholloway River is designated as Class V, which allows commercial and industrial uses. The water quality standards allowable for that river are much lower than those for a Class I water source, which provides potable water, or for a Class II water source such as the Apalachee Bay where shellfish are harvested.

Pursuant to **Rule 17-4.28, FAC**, Dredge and Fill Permits must be obtained where dredge and fill activity is undertaken in:

1. Rivers and natural tributaries thereto
2. Streams and natural tributaries thereto
3. Bays, bayous, sounds, estuaries, and natural tributaries thereto
4. Natural lakes, except those owned entirely by one person (except for lakes of no more than 10 acres of water at the maximum average depth existing throughout the year)
5. The Atlantic Ocean and Gulf of Mexico out to the state territorial boundaries

Activities exempt from dredge and fill permitting requirements are:

1. The repair or replacement of existing pipes to original configurations for the purpose of discharge of stormwater runoff
2. The construction and maintenance of swales
3. The maintenance of existing drainage ditches to their original design configurations (except when listed plants begin to grow)

Within the limits of the DEP regulations, the Department would need to obtain dredge and fill permits when new roadbeds are constructed, when new drainage systems are constructed, and when new drainage systems involving underground piping are used.

For facilities which require use of state-owned lands, DEP usually issues an easement or dedication for DOT use of state-owned submerged land. Permit applications for groin or jetty construction, beach restoration, coastal revetments, or other similar coastal construction activities which will take place in or adjacent to tidal waters of the state may require a coastal construction permit.

A.4.2 STORMWATER RUNOFF

Pursuant to **Rule 17-25.01, FAC**, the DEP regulates discharge of untreated stormwater that could be a potential source of pollution to the state. This regulatory scheme is qualitative and quantitative. All stormwater discharges must meet the water quality standards of the class of water body the stormwater actually reaches. Additionally, the rule regulates stormwater by requiring retention or retention with filtration systems that allow separation of polluting substances by percolating the water into the ground. The DEP may delegate its regulatory authority to Water Management Districts, flood control districts, and local government entities. Control of stormwater runoff has been delegated to all Water Management Districts except the Northwest.

A.4.3 DRAINAGE WELLS

Certain local situations may dictate the use of drainage wells. Typically, this would occur on barrier islands and coastal locations, where the stormwater would be introduced into saltwater and could be effective in maintaining the existing fresh/saline water interface. Groundwater withdrawal is typically not permitted in these areas. However, due to the nature of drainage wells, specific design approval for the construction of drainage wells must be granted by the State Drainage Engineer on an individual project basis.

Drainage wells are considered by the DEP to be Class V, Group 5 wells, regulated under **Chapter 17-28, FAC**. Drainage well use and treatment of the surface water prior to discharge shall be consistent with these regulations. Some existing wells and all future wells drilled into potable or potentially potable aquifers should be recognized as requiring pretreatment of the surface water prior to discharge.

It is important to understand that **17-4.245,(2)(6), FAC**, specifically disallows discharges through natural conduits such as sinkholes when there is a direct connection to certain classes of groundwater. The DEP has interpreted this to mean that a sinkhole is comparable to a drainage well when it provides a direct connection with Class G-I and Class G-II groundwater. Therefore, discharges to sinkholes that exhibit a direct connection to these classes of groundwater must be treated as discharges to a drainage well and require the same permit process.

A.5 WATER MANAGEMENT DISTRICTS

A.5.1 GENERAL

Prior to 1972, water management legislation in Florida had developed on a piecemeal basis. In that year, a comprehensive law was enacted to provide extensive protection and management of water resources throughout the state.

The **Florida 1972 Water Resources Act**, Chapter 373, **Florida Statutes**, provides a two-tiered administrative structure headed at the state level by the DEP. The DEP supervises five regional Water Management Districts designed to provide the diverse types of regulation needed in different areas of the state. These include the previously existing Central and Southern Florida Flood Control District, renamed the South Florida and the Southwest Florida Water Management Districts. Since these two districts had already been established and were authorized to levy ad valorem taxes to pay for their regulatory functions, they were promptly delegated full regulatory and permitting powers by the Department of Natural Resources (DNR), at that time the state-level regulatory agency. The three new districts established under the Act were the Suwannee River, St. Johns River, and Northwest Florida Water Management Districts.

A.5.2 BASIN BOARDS

Basin boards in the Water Management Districts handle administrative and planning functions in the particular basin, such as developing plans for secondary water control facilities and for water supply and transmission facilities for counties, municipalities, or regional water authorities. Basin boards do not exercise regulatory or permitting authority, but help to relieve the Water Management Districts of some of their administrative chores.

A.5.3 GOVERNING BOARDS

The governing boards of the Water Management Districts exercise broad statutory powers under Chapter 373, **Florida Statutes**. In regard to water works, they are authorized to:

"Clean out, straighten, enlarge, or change the course of any waterway, natural or artificial, within or without the district; to provide such canals, levees, dikes, dams, sluiceways, reservoirs, holding basins, floodways, pumping stations, bridges, highways, and other works and facilities which the board may deem necessary; establish, maintain, and regulate water levels in all canals, lakes, rivers, channels, reservoirs, streams, or other bodies of water owned or maintained by the district; cross any highway or railway with works of the district and to hold, control, and acquire by donation, lease, or purchase, or to condemn any land, public or private, needed for rights-of-way or other purposes; any way remove any building

or other obstruction necessary for the construction, maintenance, and operation of the works; and to hold and have full control over the works and rights-of-way of the district."

These boards also establish rules and regulations related to water use, adopted after public hearing and subject to review by the Governor and Cabinet sitting as the Land and Water Adjudicatory Commission.

A.5.4 PERMITTING AUTHORITY

Permitting authority has been conferred on the Water Management Districts for artificial recharge projects or the intentional introduction of water into any underground formation; the construction, repair, and abandonment of water wells; the construction or alteration of dams, impoundments, reservoirs, and other water storage projects; the licensing and registration of water well contractors; and the hookup of local water works to the district's works. Such broad regulatory powers are consistent with the declared policy of the Florida Water Resources Act for the DEP "to the greatest extent practicable," to delegate conservation, protection, management, and control authority over state waters to the Water Management Districts.

A.5.5 INTERAGENCY COOPERATION

The DEP has been concerned most directly with water quality control while the Water Management Districts have been primarily involved with water quantity control. This has inevitably resulted in regulatory overlap and confusion, since water quality and water quantity considerations are seldom mutually exclusive. This regulatory overlap has made it necessary for the DEP and the Water Management Districts to work out an effective policy to avoid confusion and redundancy in the state's regulatory scheme.

Permitting criteria overlap between the DEP and the Districts often requires permit applicants to approach both agencies for action on a single proposed activity. The extent of this overlap depends largely on the extent to which a Water Management District has implemented its own permitting authority and established a broad range of rules and regulations for water resource management within its jurisdiction. Because they were in existence prior to enactment of the Water Resources Act, the two southern districts have experienced the major share of problems with overlapping responsibilities. Negotiations between the DEP and the Water Management Districts have led to increased regulatory efficiency and greater convenience for the environmental permit applicant.

One cooperative approach has been the designation of a "primary" and "secondary" agency for specific permitting areas. Applicants would apply for a permit from the primary agency only; the secondary agency would provide input and guidance according to the terms of an interagency agreement. The DEP's Bureau of Water Resources has assigned a coordinator to attend District board meetings and act as a direct link between the agencies for the resolution of overlap problems. Also, joint quarterly meetings and the

development of standardized rules have been helpful in promoting cooperation.

In dealing with highway drainage problems and issues, the Department engineer must be aware of the rules and regulations of the Water Management District in which the project is located. Since the Department issues permits for connections to the highway drainage system, it has become even more essential from the agency's standpoint to coordinate water storage plans and state resources, and to continue to preserve comprehensive water management plans.

A.6 WATER CONTROL DISTRICTS

Prior to July 1, 1980, the DEP, or a majority of the owners, or the owners of the majority of the acreage of any contiguous body of wet or overflowed lands or lands subject to overflow situated in one or more counties were empowered pursuant to Chapter 298, **Florida Statutes**, to form water control or drainage districts for agricultural purposes, or when conclusive to the public health, convenience, and welfare, or of public utility or benefit. On July 1, 1980, Chapter 298 was amended to provide that water control districts could only be created by special act of the legislature. The drainage districts in existence prior to that time were grand fathered in.

Drainage districts are governed by a board of supervisors who are elected by the land owners in the district. The DEP's voting rights in the elections are proportional to the extent of the acreage owned by the state in the districts. Presumably, that acreage would include Department of Transportation right-of-way existing in the district.

The board of supervisors is empowered to hire a chief engineer, who is responsible for the drainage works in the area, to adopt and carry out the plan of reclamation.

The Department of Community Affairs has recently been actively charged with the responsibility of coordinating growth management in the State, which will reflect on drainage facilities and projected area growth.

A.7 GOVERNMENT PROGRAMS THAT DEAL WITH SURFACE WATER RUNOFF

Under present law, municipalities have authority to provide for drainage of city streets and reclamation of wet, low, or overflowed lands within their jurisdiction. They may construct sewers and drains and may levy special assessments on benefited property owners to pay all or part of the costs of such works. Additionally, municipalities have the power of eminent domain to condemn property for these purposes. Thus, they have the means to deal directly with storm- and surface-water runoff problems.

The general zoning power which municipalities may exercise pursuant to Chapter 166, **Florida Statutes**, enables them to enact flood plain zoning ordinances. Such ordinances may simply require compliance with special building regulations or may exclude certain

types of development in a designated flood plain. Enactment of such ordinances is another method by which municipalities can address runoff problems.

Most counties and municipalities have a drainage plan ordinance that requires submittal of a drainage plan for proposed developments. In addition, they commonly require that a drainage impact assessment be prepared and submitted if there is to be a change in the development site. Several local governments have ordinances restricting the amount of surface-water runoff that may be carried by a particular drainage system, or the amount of sediment transported by the runoff.

Many local ordinances also incorporate a flood plain regulation element or minimum elevations for old and new buildings to comply with the Federal National Flood Insurance Act of 1968 and the various current Flood Disaster Protection Acts. The virtues of flood control ordinances are multiple. As one study concluded:

"While such regulations are primarily designed to avoid direct flood damage to life and property, they yield clear benefits in the context of water quality maintenance as well. Overflows from septic tanks and combined sewers, for example, may be closely linked with improperly designed sewage and drainage systems within the flood plain. By preventing excessive encroachment of developments upon the flood plain, these special zoning laws also seem to retard rates of runoff and consequent water pollution from stream bank erosion and adjacent land surfaces."

Subdivision regulations relating to surface-water runoff control tend to be more detailed than local government ordinances, and often require submittal of a comprehensive drainage plan, approval of which is often a prerequisite for plat approval. Some regulations include runoff and rainfall criteria to which the proposed drainage system must conform, while others indicate permitted or preferred surface-water runoff control structures and techniques. Other provisions found in subdivision regulations include: a requirement that runoff from paved areas meet certain water quality standards; the encouragement or requirement of onsite retention of runoff; the regulation of grading and erosion control methods; and a monitoring requirement for the discharge of surface-water runoff into lakes, streams, and canals.

Whether the Department must comply with these local rules and programs is a question that generates great doubt and confusion. The law is so uncertain that evaluation must be made on a case-by-case basis. There are some general principles that should be observed, however. First, although there are cases that state that Department power over roads and bridges is plenary, Section 339.155(2), **Florida Statutes**, requires that the Department, in adopting its statewide transportation plan, coordinate and be consistent with local government regulations "to the maximum extent feasible." Also, in developing the Florida Transportation Plan, the Department must take into account regional and local comprehensive plans and "the total environment of the community and region, including land uses, local stormwater management plans, and social and community values." Thus as a general rule, the Department should cooperate and

comply with local regulations where such compliance would not be detrimental to the Department's interests.

However, the law is clear that the authority of a state agency prevails over local regulations when the regulations are in direct conflict with a statute or the subject of the local regulation has been preempted by the statutory scheme. In the absence of such a conflict or preemption, the courts balance the interests of the state agency versus the local governmental entity to determine whose interest is superior, and the superior interest prevails.

Appendix B

Acquisition of Real Property Rights

APPENDIX B

ACQUISITION OF REAL PROPERTY RIGHTS

B.1.1 PROPERTY PURCHASES

The Department currently purchases three types of real property interests:

- Drainage easements (permanent easements)
- Flooding and water storage easements (temporary easements)
- Fee simple title

By dividing the property needs into these categories, the Department is able to conform to requirements that empower it to take and make use of only as much real property as is necessary and best-suited to the project.

Drainage Easements

The Department acquires a permanent easement on property needed to ensure permanent maintenance of drainage facilities. Purchase of fee simple title is avoided, since the only public purpose for which the land is intended is drainage and drainage maintenance.

Under the drainage easement, the Department is empowered to remove any artificial or natural barriers which interfere with the use for which the easement was purchased. This includes fences, trees, shrubs, large root systems, or other obstacles to proper drainage or maintenance. The Department cannot be held legally accountable if actions taken to prevent hindrances to usage damage or destroy natural growth.

In many developed areas of the state, parking facilities have been built over drainage easements, with approval contingent on installation of piping that continues to satisfy the Department's objectives. The following conditions also apply:

- The design must be for ground level parking facilities.
- The Department will not be responsible for the cost of piping needed to maintain Department standards for the easement.
- The costs borne by the fee simple owner include design, construction, and the Department's inspection activities.

Since maintenance or roadway reconstruction activities may require removal of some or all of the parking facility, the Department should make sure that any agreement specifically releases it from any liability for physical damage to or loss of use of the facility.

Flooding and Water Storage Easements

On occasion, water from heavy rainfall events or non-permitted drainage hookups will exceed the design limits of the highway drainage system, leaving the closed system and flowing onto land the Department does not own. When areas where this may occur can be determined in advance and when such flooding occurs under a limited set of conditions and is temporary in nature, the Department may acquire a temporary flooding easement. This gives the Department flood rights, allowing temporary use of private property to ease flooding. The flood easement may or may not define conditions under which flooding may occur and the elevation water would be expected to reach under those conditions. Emphasis is placed on public safety and cost when negotiating for the easement.

Flood rights are usually purchased on land in a natural state, which already floods under certain weather conditions from non-highway sources. An example of this type of land is a land-locked natural basin, such as those found in northern Florida.

To provide a retention or detention storage area for discharging water from the closed highway drainage system, the Department may purchase either a temporary or permanent water storage easement. This storage area may allow the water to be transported to waterways of the state or to evaporate or percolate into the soil over time, and may be in response to certain temporary conditions or can become part of the drainage system design.

Many current comprehensive county zoning plans require that developers provide storage for runoff that occurs from land development. Since these storage areas are generally available to public and private entities, the Department should consider their use whenever possible and only purchase storage rights needed for roadway drainage when no other alternative is available.

Fee Simple Title

The decision to purchase fee simple title rather than an easement to real property should be made on a case-by-case basis that evaluates the benefits in terms of public safety and convenience against the additional cost. A typical example would be property containing open drainage ditches with sufficient depth or velocity to pose a clear and present hazard to the public. Possession of fee simple title would allow the Department to fence the property and otherwise minimize potential dangers in accordance with state safety standards.

B.1.2 PROPERTY EXCHANGES

As a general rule, either rights-of-way or easements can be exchanged in kind between the Department and a property owner when the exchange is requested by the property owner and no additional costs or inconveniences will be borne by the Department as a

result of the exchange. All costs of necessary reconstruction, legal services, documentation, or recording the exchange will be borne by the property owner. Before the exchange is approved, the Department must evaluate the potential for use, liabilities, and increased maintenance engendered by the exchange.

B.1.3 CRITERIA FOR ESTABLISHING PROPERTY INTERESTS

This manual establishes the minimum criteria for establishing property interests for drainage purposes, including width and alignments. A sufficient additional allowance should be provided for construction and maintenance requirements.

Appendix C

Cover Height Tables

Appendix C

COVER HEIGHT TABLES

The following tables have been calculated for FDOT based on FDOT **Standard Specification 125**. If the design of the pipe requires unique installation requirements, varying from the standard specification, the EOR shall compute pipe cover in accordance with the **AASHTO LRFD Design Manual**.

Notable Abbreviations

NA – Not Available

NS – Not Suitable (For Highway LRFD HL-93 Live Loadings)

General Notes

1. The tabulated values are recommended minimum dimensions to withstand anticipated highway traffic loads. Additional cover may be required to support construction equipment loads or highway traffic loads before pavement is completed. Some size thickness combinations may require minimum cover greater than those listed within this appendix.
2. Tabulated values are based on the guidelines found in the AASHTO LRFD Design Manual and other general site design assumptions. Alternative values may be used in lieu of the values tabulated within this appendix based on site specific calculations developed by suitable methods and detailed in the plans. The assumptions made for use in the development of the tabulated values include:
 - a. 120 lb/cubic ft Soil Density
 - b. The pipes will be installed at or above the established water table
 - c. Pipe trench excavation per FDOT Specification 125-4.4
 - d. Pipe trench backfill allowable soils, bedding and compaction per FDOT Specification 125-8
 - e. Pipes maximum deflection = 5% per FDOT Specification 430-8
 - f. Pipes maximum strains per AASHTO
3. Minimum cover is calculated as shown in the figures for each pipe type. If the minimum cover provided is not sufficient to avoid placement of the pipe within the base course, then the minimum cover should be increased to a minimum of the bottom of base course.
4. Maximum cover is measured from top of finished grade to the outside crown of pipe for all pipe shapes and types.
5. Unless otherwise noted, the minimum cover in unpaved areas shall be the same as with flexible pavement.

CONCRETE PIPE ROUND & ELLIPTICAL

Minimum Cover

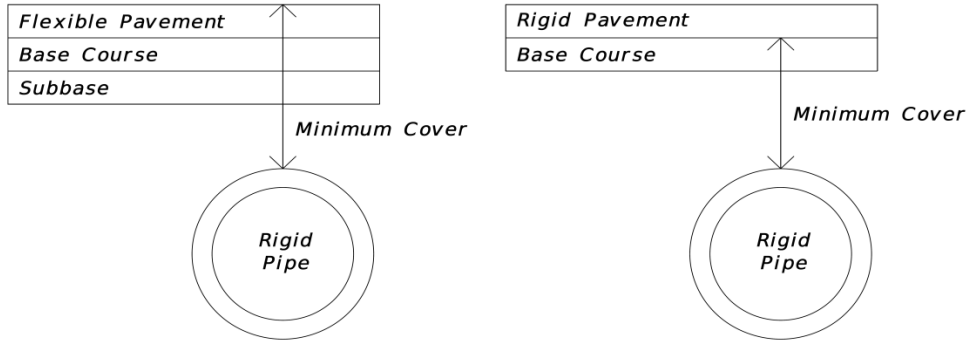

Concrete Pipe Minimum Cover

Unpaved or Flexible Pavement	Rigid Pavement
12 in.	9 in.

CONCRETE PIPE – ROUND

Maximum Cover

Round Pipe (B Wall) - Type I Installation					
Pipe Diameter	Maximum Cover (ft)				
	Class I	Class II	Class III	Class IV	Class V
12"	11	16	22	34	45
15"	12	16	23	34	45
18"	12	16	23	35	45
24"	11	16	22	34	45
30"	11	15	22	34	45
36"	11	15	21	33	45
42"	10	15	21	33	45
48"	10	14	21	32	45
54"	10	14	21	32	45
60"	9	14	20	32	45
66"	9	13	20	31	45
72"	7	12	18	29	45
78"	7	12	18	29	45
84"	7	12	18	29	45
90"	6	11	18	29	45
96"	5	11	18	29	45
102"	-	11	17	28	45
108"	-	11	17	28	45
114"	-	11	17	28	45
120"	-	10	17	28	44

Pipe Class I D-Load = 800 Lbs./Ft./Ft. (0.01" Crack)
 D-Load = 1200 Lbs./Ft./Ft. (Ultimate)

Pipe Class II D-Load = 1000 Lbs./Ft./Ft. (0.01" Crack)
 D-Load = 1500 Lbs./Ft./Ft. (Ultimate)

Pipe Class III D-Load = 1350 Lbs./Ft./Ft. (0.01" Crack)
 D-Load = 2000 Lbs./Ft./Ft. (Ultimate)

Pipe Class IV D-Load = 2000 Lbs./Ft./Ft. (0.01" Crack)
 D-Load = 3000 Lbs./Ft./Ft. (Ultimate)

Pipe Class V D-Load = 3000 Lbs./Ft./Ft. (0.01" Crack)
 D-Load = 3750 Lbs./Ft./Ft. (Ultimate)

Concrete Pipe - Round Dimensions		
Equiv. Dia. (in)	Area (Sq. Ft.)	Wall Thickness (in.)* Classes II, III, IV, V B Wall
12	0.8	2
15	1.2	2 1/4
18	1.8	2 1/2
24	3.1	3
30	4.9	3 1/2
36	7.1	4
42	9.6	4 1/2
48	12.6	5
54	15.9	5 1/2
60	19.6	6
66	23.8	6 1/2
72	28.3	7
78	33.2	7 1/2
84	38.5	8
90	44.4	8 1/2
96	50.3	9
102	56.7	9 1/2
108	63.7	10
114	70.9	-
120	78.5	-
* For Informational Purposes Only. Do Not Specify Wall Thickness. Option B Wall is Industry Standard.		

CONCRETE PIPE – ELLIPTICAL

Maximum Cover

Elliptical Pipe - Installation Type II						
Pipe Equiv. ID	Span	Rise	Maximum Cover (ft)			
			Class HE-I	Class HE-II	Class HE-III	Class HE-IV
18"	23"	14"	8	12	17	25
24"	30"	19"	8	11	16	25
30"	38"	24"	8	11	16	25
36"	45"	29"	8	11	16	25
42"	53"	34"	7	11	16	25
48"	60"	38"	7	11	16	25
54"	68"	43"	7	11	16	25
60"	76"	48"	7	10	15	24
66"	83"	53"	7	10	15	24
72"	91"	58"	6	10	15	24
78"	98"	63"	6	10	15	24
84"	106"	68"	6	10	15	24
90"	113"	72"	6	10	15	24
96"	121"	77"	5	9	15	24
102"	128"	82"	5	9	14	23
108"	136"	87"	5	9	14	23
114"	143"	92"	5	9	14	23
120"	151"	97"	5	9	14	23

Pipe Class HE II And VE II	D-Load = 1000 Lbs./Ft./Ft. (0.01" Crack) D-Load = 1500 Lbs./Ft./Ft. (Ultimate)
Pipe Class HE III And VE III	D-Load = 1350 Lbs./Ft./Ft. (0.01" Crack) D-Load = 2000 Lbs./Ft./Ft. (Ultimate)
Pipe Class HE IV And VE IV	D-Load = 2000 Lbs./Ft./Ft. (0.01" Crack) D-Load = 3000 Lbs./Ft./Ft. (Ultimate)

Concrete Pipe - Elliptical Dimensions						
Nominal Dimensions				Equiv. Dia. (in.)	Area (Sq. Ft.)	Wall Thickness (in.)
Horiz.		Vert.				Classes HE II, III, IV VE II, III, IV
Rise (in.)	Span (in.)	Rise (in.)	Span (in.)			
12	18	18	12	15	1.3	2 ^{1/2}
14	23	23	14	18	1.8	2 ^{3/4}
19	30	30	19	24	3.3	3 ^{1/4}
24	38	38	24	30	5.1	3 ^{3/4}
29	45	45	29	36	7.4	4 ^{1/2}
34	53	53	34	42	10.2	5
38	60	60	38	48	12.9	5 ^{1/2}
43	68	68	43	54	16.6	6
48	76	76	48	60	20.5	6 ^{1/2}
53	83	83	53	66	24.8	7
58	91	91	58	72	29.5	7 ^{1/2}
63	98	98	63	78	34.6	8
68	106	106	68	84	40.1	8 ^{1/2}
72	113	113	72	90	46.1	9
77	121	121	77	96	52.4	9 ^{1/2}
82	128	128	82	102	59.2	10
87	136	136	87	108	66.4	10 ^{1/2}
92	143	143	92	114	74	11
97	151	151	97	120	82	11 ^{1/2}

* For Informational Purposes Only.

PLASTIC PIPE

Minimum Cover

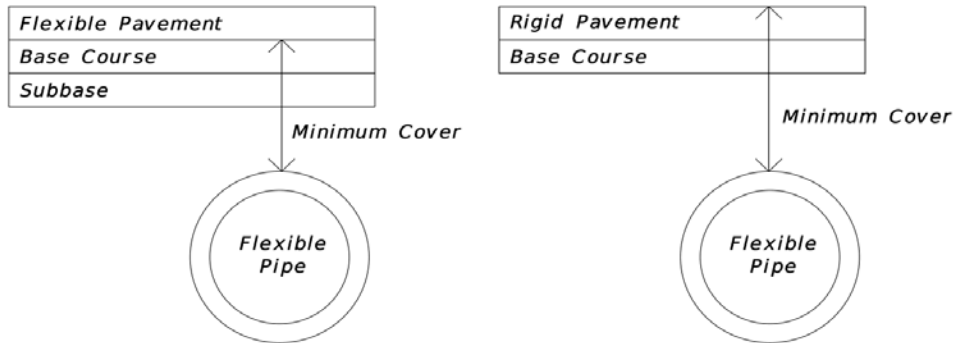

Note: Unpaved areas shall have a minimum cover of 12 inches

Pipe Type & Size	Minimum Cover (in)
Corrugated Polyethylene	
12" - 48"	24
60"	30
Corrugated Polypropylene	
12" - 48"	24
60"	30
Corrugated Polyvinylchloride	24
Steel Reinforced Polyethylene	12

Maximum Cover

Corrugated Polyethylene Pipe	
Diameter	Max Cover (ft)
12"	19
15"	20
18"	17
24"	13
30"	13
36"	14
42"	13
48"	12
60"	13

Corrugated Polypropylene Pipe	
Diameter	Max Cover (ft)
12"	21
15"	22
18"	19
24"	16
30"	19
36"	16
42"	15
48"	15
60"	16

Corrugated Polyvinylchloride Pipe	
Diameter	Max Cover (ft)
12"	42
15"	45
18"	42
21"	41
24"	41
30"	40
36"	40

Steel Reinforced Polyethylene Pipe	
Diameter	Max Cover (ft)
30"-42"	50
48"-60"	30

Corrugated Aluminum Pipe

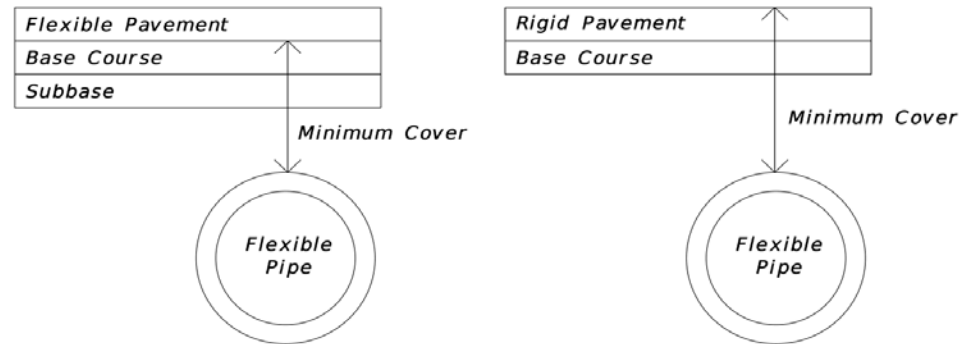

Aluminum - Round Pipe - 2 2/3" x 1/2" Corrugation											
D (in.)	Area (sq. ft.)	Minimum Cover (in.)					Maximum Cover (ft.)				
		Sheet thickness in Inches (Gage)					Sheet thickness in Inches (Gage)				
		0.06 (16)	0.075 (14)	0.105 (12)	0.135 (10)	0.164 (8)	0.06 (16)	0.075 (14)	0.105 (12)	0.135 (10)	0.164 (8)
12	0.8	12	12	NA	NA	NA	100+	100+	NA	NA	NA
15	1.2	12	12	NA	NA	NA	100+	100+	NA	NA	NA
18	1.8	12	12	12	NA	NA	83	100+	100+	NA	NA
21	2.4	12	12	12	NA	NA	71	89	100+	NA	NA
24	3.1	12	12	12	NA	NA	62	78	100+	NA	NA
30	4.9	12	12	12	NA	NA	50	62	87	NA	NA
36	7.1	NS	12	12	12	NA	NS	52	73	94	NA
42	9.6	NS	NS	12	12	NA	NS	NS	62	80	NA
48	12.6	NS	NS	12	12	12	NS	NS	54	70	86
54	15.9	NS	NS	NS	12	12	NS	NS	NS	62	76
60	19.6	NS	NS	NS	NS	NS	NS	NS	NS	NS	NS
66	23.8	NS	NS	NS	NS	NS	NS	NS	NS	NS	NS
72	28.3	NS	NS	NS	NS	NS	NS	NS	NS	NS	NS

Aluminum - Round Pipe - 3" x 1" Corrugation											
D (in.)	Area (sq. ft.)	Minimum Cover (in.)					Maximum Cover (ft.)				
		Sheet thickness in Inches (Gage)					Sheet thickness in Inches (Gage)				
		0.06	0.075	0.105	0.135	0.164	0.06	0.075	0.105	0.135	0.164
		(16)	(14)	(12)	(10)	(8)	(16)	(14)	(12)	(10)	(8)
36	7.1	12	12	12	NA	NA	47	60	84	NA	NA
42	9.6	12	12	12	NA	NA	40	51	72	NA	NA
48	12.6	12	12	12	12	NA	35	44	62	84	NA
54	15.9	12	12	12	12	NA	31	39	55	74	NA
60	19.6	12	12	12	12	NA	28	35	50	67	NA
66	23.8	12	12	12	12	12	25	32	45	61	72
72	28.3	NS	12	12	12	12	NS	29	41	55	65
78	33.2	NS	12	12	12	12	NS	26	38	51	60
84	38.5	NS	NS	12	12	12	NS	NS	35	47	56
90	44.2	NS	NS	12	12	12	NS	NS	32	44	52
96	50.3	NS	NS	12	12	12	NS	NS	30	41	48
102	56.7	NS	NS	NS	13	13	NS	NS	NS	38	45
108	63.6	NS	NS	NS	NS	NS	NS	NS	NS	NS	NS
114	70.9	NS	NS	NS	NS	NS	NS	NS	NS	NS	NS
120	78.5	NS	NS	NS	NS	NS	NS	NS	NS	NS	NS

Aluminum - Round Pipe - Spiral Rib Rib Spacing (3/4" x 3/4" x 7 1/2")									
D (in.)	Area (sq. ft.)	Minimum Height of Fill (in.)				Maximum Height of Fill (ft.)			
		Sheet thickness in Inches (Gage)				Sheet thickness in Inches (Gage)			
		0.06 (16)	0.075 (14)	0.105 (12)	0.135 (10)	0.06 (16)	0.075 (14)	0.105 (12)	0.135 (10)
12	0.79	NA	NA	NA	NA	NA	NA	NA	NA
15	1.23	12	12	NA	NA	53	73	NA	NA
18	1.77	12	12	NA	NA	44	61	NA	NA
21	2.4	12	12	NA	NA	38	52	NA	NA
24	3.14	12	12	NA	NA	33	45	NA	NA
30	4.91	15	15	15	NA	26	36	59	NA
36	7.1	24	18	18	NA	*21	30	49	NA
42	9.6	NS	21	21	NA	NS	*25	41	NA
48	12.6	NS	NS	24	24	NS	NS	36	51
54	16	NS	NS	24	24	NS	NS	32	45
60	19.6	NS	NS	24	24	NS	NS	*28	41
66	23.8	NS	NS	NS	24	NS	NS	NS	37

* Special installation required. Refer to AASHTO Standard Specifications for Highway Bridges or ASTM B788-88 and manufacturer's recommendations.

CORRUGATED STEEL ROUND

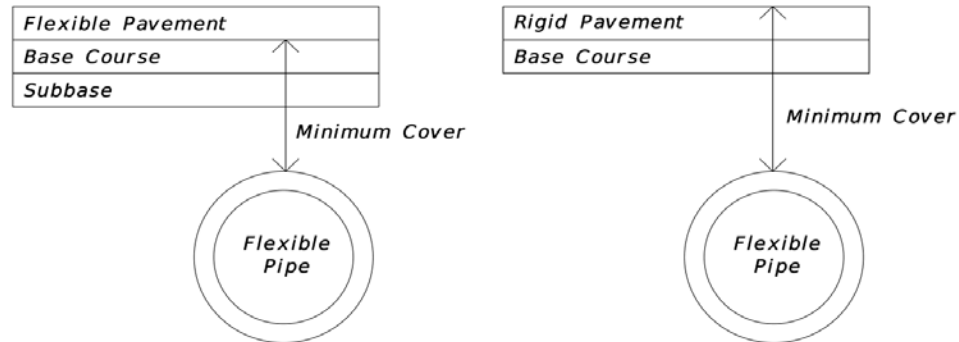

Steel - Round Pipe - 2 2/3" x 1/2" Corrugation											
D (in.)	Area (sq. ft.)	Minimum Cover (in.)					Maximum Cover (ft.)				
		Sheet thickness in Inches (Gage)					Sheet thickness in Inches (Gage)				
		0.064 (16)	0.079 (14)	0.109 (12)	0.138 (10)	0.168 (8)	0.064 (16)	0.079 (14)	0.109 (12)	0.138 (10)	0.168 (8)
12	0.79	12	12	NA	NA	NA	100+	100+	NA	NA	NA
15	1.23	12	12	NA	NA	NA	100+	100+	NA	NA	NA
18	1.77	12	12	12	NA	NA	100+	100+	100+	NA	NA
21	2.4	12	12	12	NA	NA	100+	100+	100+	NA	NA
24	3.14	12	12	12	NA	NA	100+	100+	100+	NA	NA
30	4.91	12	12	12	NA	NA	82	100+	100+	NA	NA
36	7.1	12	12	12	12	NA	68	86	100+	100+	NA
42	9.6	12	12	12	12	NA	51	73	100+	100+	NA
48	12.6	12	12	12	12	12	40	64	90	100+	100+
54	16	12	12	12	12	12	NS	57	80	100+	100+
60	19.6	NS	NS	12	12	12	NS	NS	72	93	100+
66	23.8	NS	NS	12	12	12	NS	NS	NS	84	100+
72	28.3	NS	NS	NS	12	12	NS	NS	NS	77	94
78	33.2	NS	NS	NS	NS	12	NS	NS	NS	NS	87
84	38.5	NS	NS	NS	NS	12	NS	NS	NS	NS	80

Steel - Round Pipe - 3" x 1" Corrugation											
D (in.)	Area (sq. ft.)	Minimum Cover (in.)					Maximum Cover (ft.)				
		Sheet thickness in Inches (Gage)					Sheet thickness in Inches (Gage)				
		0.064 (16)	0.079 (14)	0.109 (12)	0.138 (10)	0.168 (8)	0.064 (16)	0.079 (14)	0.109 (12)	0.138 (10)	0.168 (8)
36	7.1	12	12	12	NA	NA	79	99	100+	NA	NA
42	9.6	12	12	12	NA	NA	67	84	100+	NA	NA
48	12.6	12	12	12	12	NA	59	74	100+	100+	NA
54	16	12	12	12	12	NA	52	65	92	100+	NA
60	19.6	12	12	12	12	NA	47	59	83	100+	NA
66	23.8	12	12	12	12	12	42	53	75	97	100
72	28.3	12	12	12	12	12	38	48	69	89	100
78	33.2	12	12	12	12	12	35	45	63	82	100
84	38.5	12	12	12	12	12	33	41	58	76	93
90	44.2	12	12	12	12	12	30	38	54	70	87
96	50.3	NS	12	12	12	12	NS	36	51	66	81
102	56.7	NS	13	13	13	13	NS	33	48	62	76
108	63.6	NS	NS	14	14	14	NS	NS	45	58	72
114	70.9	NS	NS	15	15	15	NS	NS	42	55	68
120	78.5	NS	NS	15	15	15	NS	NS	40	52	64
132	95	NS	NS	NS	17	17	NS	NS	NS	47	58

Steel - Round Pipe - Spiral Rib Rib Spacing 3/4" x 3/4" x 7 1/2"									
D (in.)	Area (sq. ft.)	Minimum Cover (in.)				Maximum Cover (ft.)			
		Sheet thickness in Inches (Gage)				Sheet thickness in Inches (Gage)			
		0.064 (16)	0.079 (14)	0.109 (12)	0.138 (10)	0.064 (16)	0.079 (14)	0.109 (12)	0.138 (10)
12	0.79	NA	NA	NA	NA	NA	NA	NA	NA
15	1.23	NA	NA	NA	NA	NA	NA	NA	NA
18	1.77	12	12	NA	NA	90	100+	NA	NA
21	2.4	12	12	12	NA	77	100+	100+	NA
24	3.14	12	12	12	12	68	95	100+	100+
30	4.91	12	12	12	12	54	76	100+	100+
36	7.1	12	12	12	12	45	63	100+	100+
42	9.6	12	12	12	12	38	54	90	100+
48	12.6	12	12	12	12	33	47	78	100+
54	16	14	14	14	14	29	41	70	100+
60	19.6	NS	15	15	15	NS	37	62	91
66	23.8	NS	17	17	17	NS	33	57	83
72	28.3	NS	NS	18	18	NS	NS	52	76
78	33.5	NS	NS	20	20	NS	NS	48	70
84	38.5	NS	NS	21	21	NS	NS	44	64
90	44.2	NS	NS	NS	23	NS	NS	NS	60
96	50.3	NS	NS	NS	NS	NS	NS	NS	NS
102	56.7	NS	NS	NS	NS	NS	NS	NS	NS
108	63.6	NS	NS	NS	NS	NS	NS	NS	NS

Corrugated Aluminum Pipe Arch

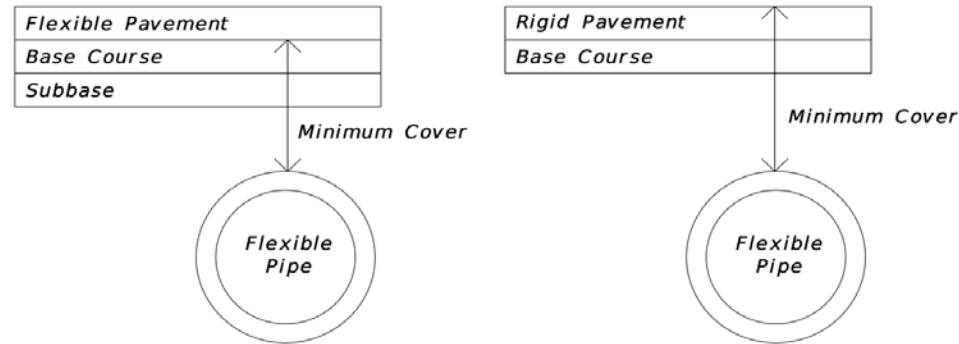

Aluminum - Pipe Arch- 2 2/3" x 1/2" Corrugation												
Equivalent Diameter D (in.)	Span in.	Rise in.	Minimum Cover (in.)					Maximum Cover (ft)				
			Sheet thickness in Inches (Gage)					Sheet thickness in Inches (Gage)				
			0.06 (16)	0.075 (14)	0.105 (12)	0.135 (10)	0.164 (8)	0.06 (16)	0.075 (14)	0.105 (12)	0.135 (10)	0.164 (8)
15	17	13	33	28	28	28	28	12	12	12	12	12
18	21	15	30	30	30	30	30	11	11	11	11	11
21	24	18	27	27	27	27	27	12	12	12	12	12
24	28	20	29	29	29	29	29	11	11	11	11	11
30	35	24	NS	29	29	29	29	NS	11	11	11	11
36	42	29	NS	30	30	30	30	NS	11	11	11	11
42	49	33	NS	NS	30	30	30	NS	NS	11	11	11
48	57	38	NS	NS	NS	NS	NS	NS	NS	NS	NS	NS
54	64	43	NS	NS	NS	NS	NS	NS	NS	NS	NS	NS
60	71	47	NS	NS	NS	NS	NS	NS	NS	NS	NS	NS

Aluminum - Pipe Arch - 3" x 1" Corrugation												
Equivalent Diameter D (in.)	Span in.	Rise in.	Minimum Cover (in.)					Maximum Cover (ft)				
			Sheet thickness in Inches (Gage)					Sheet thickness in Inches (Gage)				
			0.06 (16)	0.075 (14)	0.105 (12)	0.135 (10)	0.164 (8)	0.06 (16)	0.075 (14)	0.105 (12)	0.135 (10)	0.164 (8)
48	53	41	12	12	12	12	12	20	20	20	20	20
54	60	46	12	12	12	12	12	20	20	20	20	20
60	66	51	12	12	12	12	12	20	20	20	20	20
66	73	55	NS	12	12	12	12	NS	20	20	20	20
72	81	59	NS	NS	12	12	12	NS	NS	16	16	16
78	87	63	NS	NS	12	12	12	NS	NS	16	16	16
84	95	67	NS	NS	12	12	12	NS	NS	16	16	16
90	103	71	NS	NS	NS	13	13	NS	NS	NS	15	15
96	112	75	NS	NS	NS	NS	NS	NS	NS	NS	NS	NS
102	117	79	NS	NS	NS	NS	NS	NS	NS	NS	NS	NS

Aluminum - Pipe Arch- Spiral Rib Rib Spacing (3/4" x 3/4" x 7 1/2")										
Equivalent Diameter D (in.)	Span in.	Rise in.	Minimum Cover (in.)				Maximum Cover (ft)			
			Sheet thickness in Inches (Gage)				Sheet thickness in Inches (Gage)			
			0.06 (16)	0.075 (14)	0.105 (12)	0.135 (10)	0.06 (16)	0.075 (14)	0.105 (12)	0.135 (10)
18	20	16	23	23	23	23	15	15	15	15
21	23	19	24	24	24	24	14	14	14	14
24	27	21	26	26	26	26	12	12	12	12
30	33	26	26	26	26	26	12	12	12	12
36	40	31	27	27	27	27	12	12	12	12
42	46	36	24	24	24	24	12	12	12	12
48	53	41	NS	24	24	24	NS	14	14	14
54	60	46	NS	24	24	24	NS	17	20	20
60	66	51	NS	24	24	24	NS	17	20	20
66	73	55	NS	NS	27	27	NS	NS	20	20

Corrugated Steel Pipe Arch

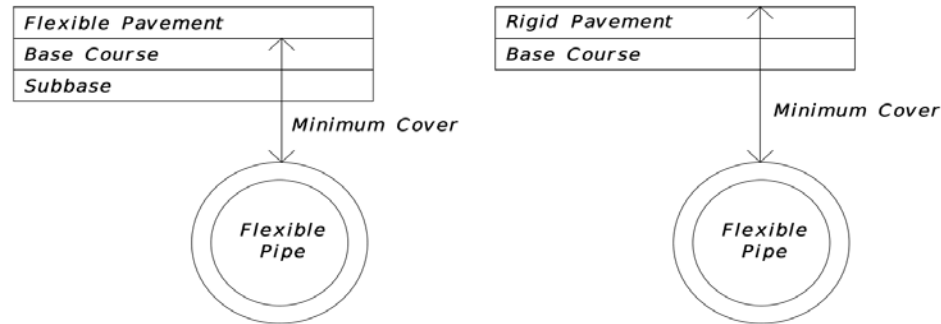

Steel - Pipe Arch - 2 2/3" x 1/2" Corrugation												
Equivalent Diameter D (in.)	Span in.	Rise in.	Minimum Cover (in.)					Maximum Cover (ft)				
			Sheet thickness in Inches (Gage)					Sheet thickness in Inches (Gage)				
			0.064 (16)	0.079 (14)	0.109 (12)	0.138 (10)	0.168 (8)	0.064 (16)	0.079 (14)	0.109 (12)	0.138 (10)	0.168 (8)
15	17	13	28	28	28	28	28	12	12	12	12	12
18	21	15	30	30	30	30	30	11	11	11	11	11
21	24	18	27	27	27	27	27	12	12	12	12	12
24	28	20	29	29	29	29	29	11	11	11	11	11
30	35	24	29	29	29	29	29	11	11	11	11	11
36	42	29	30	30	30	30	30	11	11	11	11	11
42	49	33	NS	30	30	30	30	NS	11	11	11	11
48	57	38	NS	NS	23	25	23	NS	NS	11	11	11
54	64	43	NS	NS	20	20	20	NS	NS	11	11	11
60	71	47	NS	NS	NS	22	22	NS	NS	NS	10	10
66	77	52	NS	NS	NS	NS	NS	NS	NS	NS	NS	NS
72	83	57	NS	NS	NS	NS	NS	NS	NS	NS	NS	NS

Steel - Pipe Arch - 3" x 1" Corrugation												
Equivalent Diameter D (in.)	Span in.	Rise in.	Minimum Cover (in.)					Maximum Cover (ft)				
			Sheet thickness in Inches (Gage)					Sheet thickness in Inches (Gage)				
			0.064 (16)	0.079 (14)	0.109 (12)	0.138 (10)	0.168 (8)	0.064 (16)	0.079 (14)	0.109 (12)	0.138 (10)	0.168 (8)
48	53	41	12	12	12	12	12	20	20	20	20	20
54	60	46	12	12	12	12	12	20	20	20	20	20
60	66	51	12	12	12	12	12	20	20	20	20	20
66	73	55	12	12	12	12	12	20	20	20	20	20
72	81	59	12	12	12	12	12	16	16	16	16	16
78	87	63	12	12	12	12	12	16	16	16	16	16
84	95	67	NS	12	12	12	12	NS	16	16	16	16
90	103	71	NS	NS	13	13	13	NS	NS	15	15	15
96	112	75	NS	NS	14	14	14	NS	NS	15	15	15
102	117	79	NS	NS	15	15	15	NS	NS	15	15	15
108	128	83	NS	NS	NS	16	16	NS	NS	NS	15	15
114	137	87	NS	NS	NS	18	18	NS	NS	NS	15	15
120	142	91	NS	NS	NS	NS	18	NS	NS	NS	NS	15

Steel - Pipe Arch - Spiral Rib										
Rib Spacing (3/4" x 3/4" x 7 1/2")										
Equivalent Diameter D (in.)	Span in.	Rise in.	Minimum Cover (in.)				Maximum Cover (ft)			
			Sheet thickness in Inches (Gage)				Sheet thickness in Inches (Gage)			
			0.064 (16)	0.079 (14)	0.109 (12)	0.138 (10)	0.064 (16)	0.079 (14)	0.109 (12)	0.138 (10)
18	20	16	23	23	23	23	15	15	15	15
21	23	19	24	24	24	24	14	14	14	14
24	27	21	26	26	26	26	12	12	12	12
30	33	26	26	26	26	26	12	12	12	12
36	40	31	27	27	27	27	12	12	12	12
42	46	36	24	24	24	24	12	12	12	12
48	53	41	NS	18	18	18	NS	12	12	12
54	60	46	NS	15	15	15	NS	20	20	20
60	66	51	NS	NS	17	17	NS	NS	20	20

Appendix D

Pipes within Walled Embankment Sections

Wall Zone Criteria

Wall Zone	Requirements	Comments
A	Wall Zone Pipe (see Drainage Manual Table 6-1)	Not likely to leak and used when probable first indicator of leak is topside settlement or soil loss
B	Wall Zone Pipe. No longitudinal conveyances ² allowed. Transverse conveyances must meet AASHTO LRFD criteria ³	First indicator of leak is wall damage: pipe must endure unique loading with no chance of leakage
C	No pipes allowed	First indicator of leak is bridge damage

Notes

1. Requirements apply to all retaining walls including those shown in the following sketches. Wall types not shown or project specific wall designs shall incorporate the same restrictions.
2. For the purposes of this table and these figures, a longitudinal conveyance is defined as a pipe run that is aligned with the wall stationing and deviating no more than 45 degrees from the wall alignment. For skewed walls and in the cases where the criteria for longitudinal and transverse directions overlap, e.g., at wall corners, the more stringent criteria must apply.
3. The structural analysis of the pipe must satisfy AASHTO LRFD Bridge Design Specifications, Chapter 12. Pipes in Zone B must be designed to provide adequate structural integrity after the expected section loss due to corrosion over the design service life of the pipe. LRFD assumptions are listed below:
 - a. 120 lb/cubic ft Soil Density (moist)
 - b. Pipe trench excavation per Subarticle 125-4.4 of the **FDOT Specifications**
 - c. Pipe trench backfill allowable soils, bedding and compaction per Article 125-8 of the **FDOT Specifications**
4. Special design constraints may be imposed when a pressurized pipe is placed within, through, under, or immediately adjacent to a retaining wall. This is to assure the design of structural elements takes into consideration support limitations that may be created by the presence of utilities and potential damage or failure of the structure if a pressurized pipe leaks.
5. French Drains are not permitted within any retained earth (walled) embankment sections or wall zones.
6. Hydraulically size drainage pipes to allow for future internal lining.
7. Two-phased MSE walls, per SDG 3.12.1.D, are used when significant settlement is expected. For two-phased MSE walls, transverse piping must be installed after as much of the settlement as practical has occurred. Coordinate this effort with the Geotechnical Engineer.

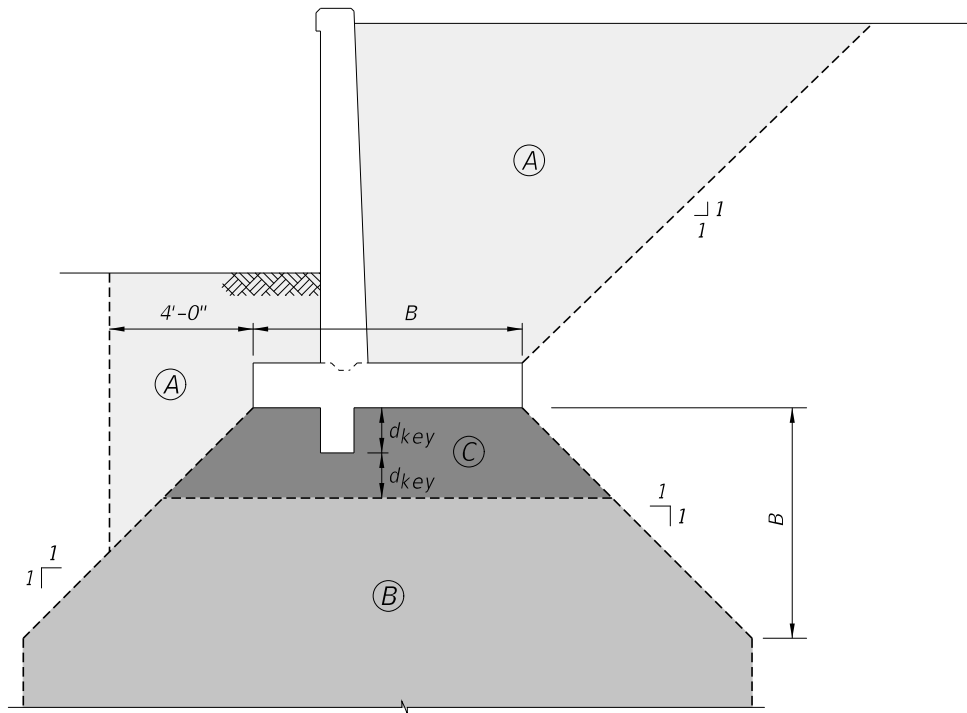

SECTION THRU CAST IN PLACE CANTILEVER RETAINING WALL (INDEX 6010)

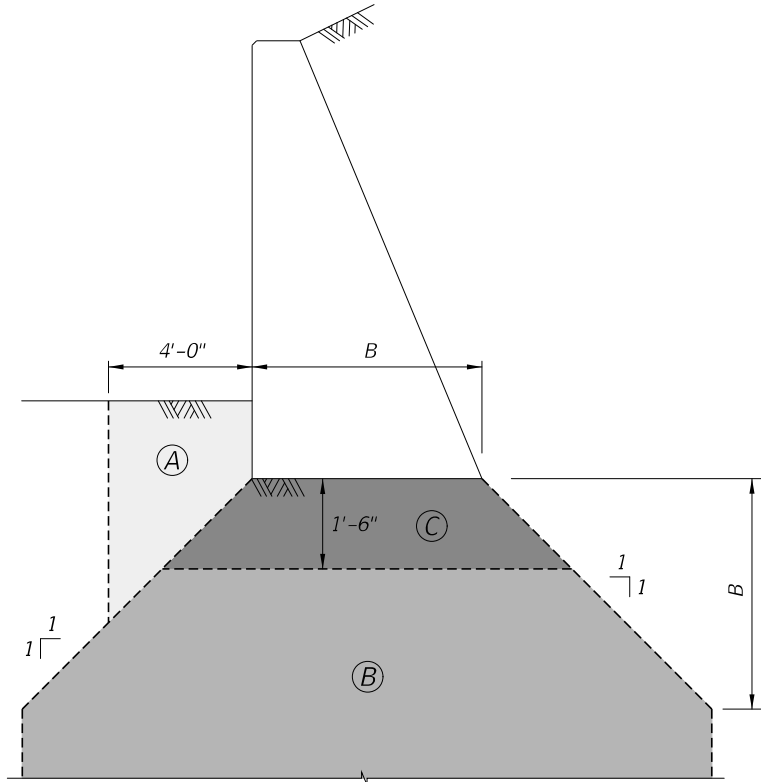

SECTION THRU CAST IN PLACE GRAVITY WALL (INDEX 6011)

Figure F-1

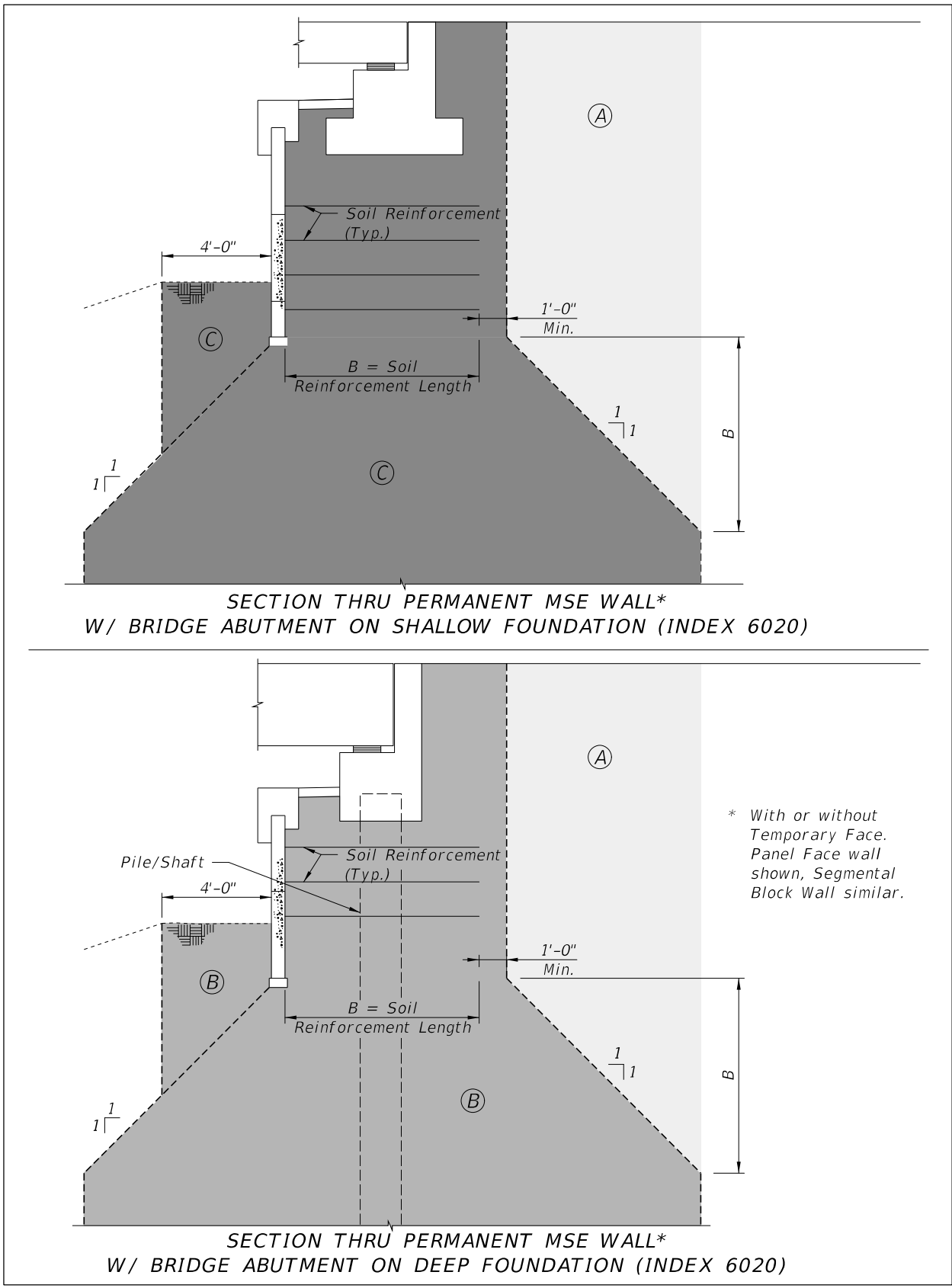

Figure F-2

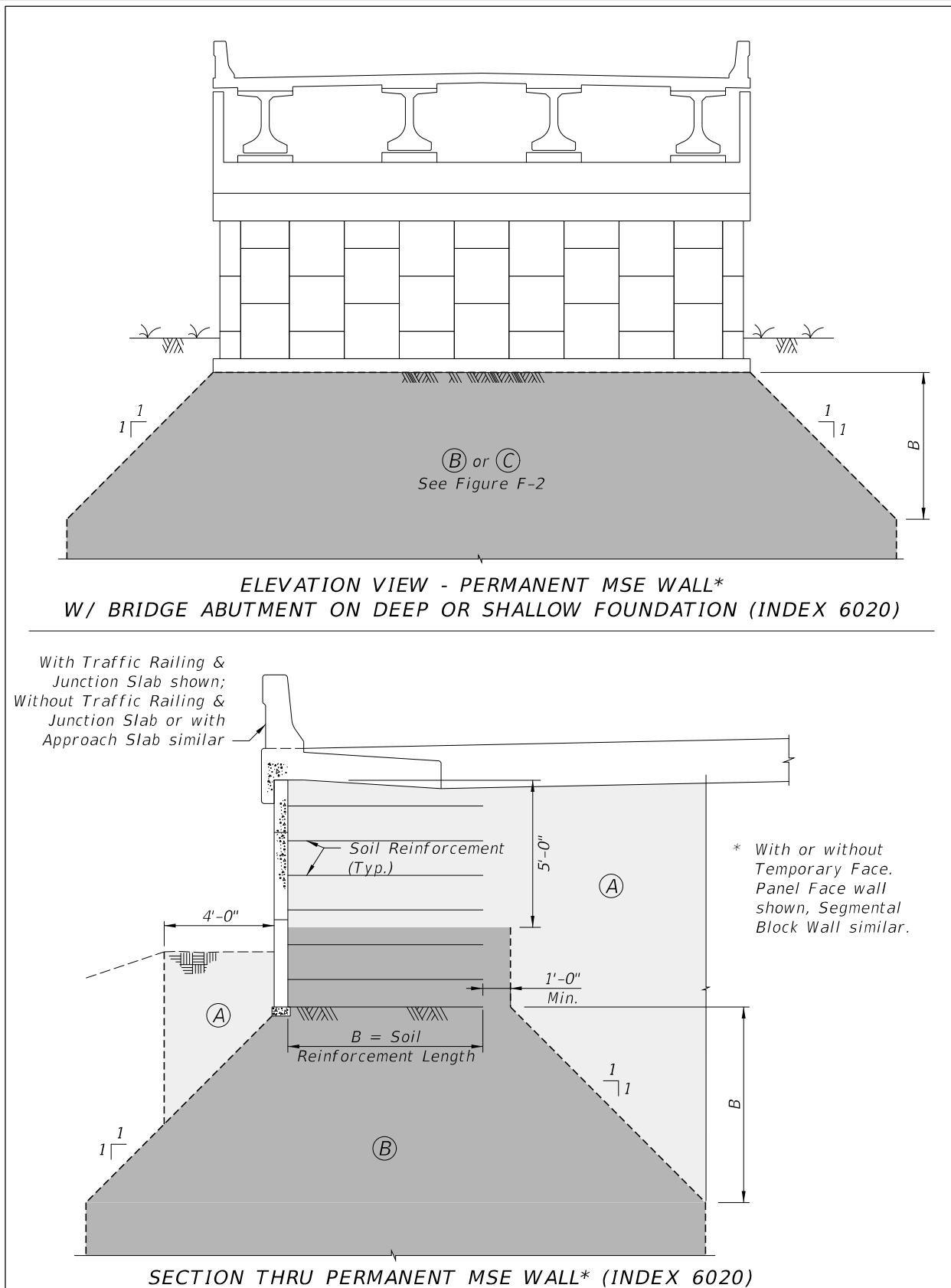

Figure F-3

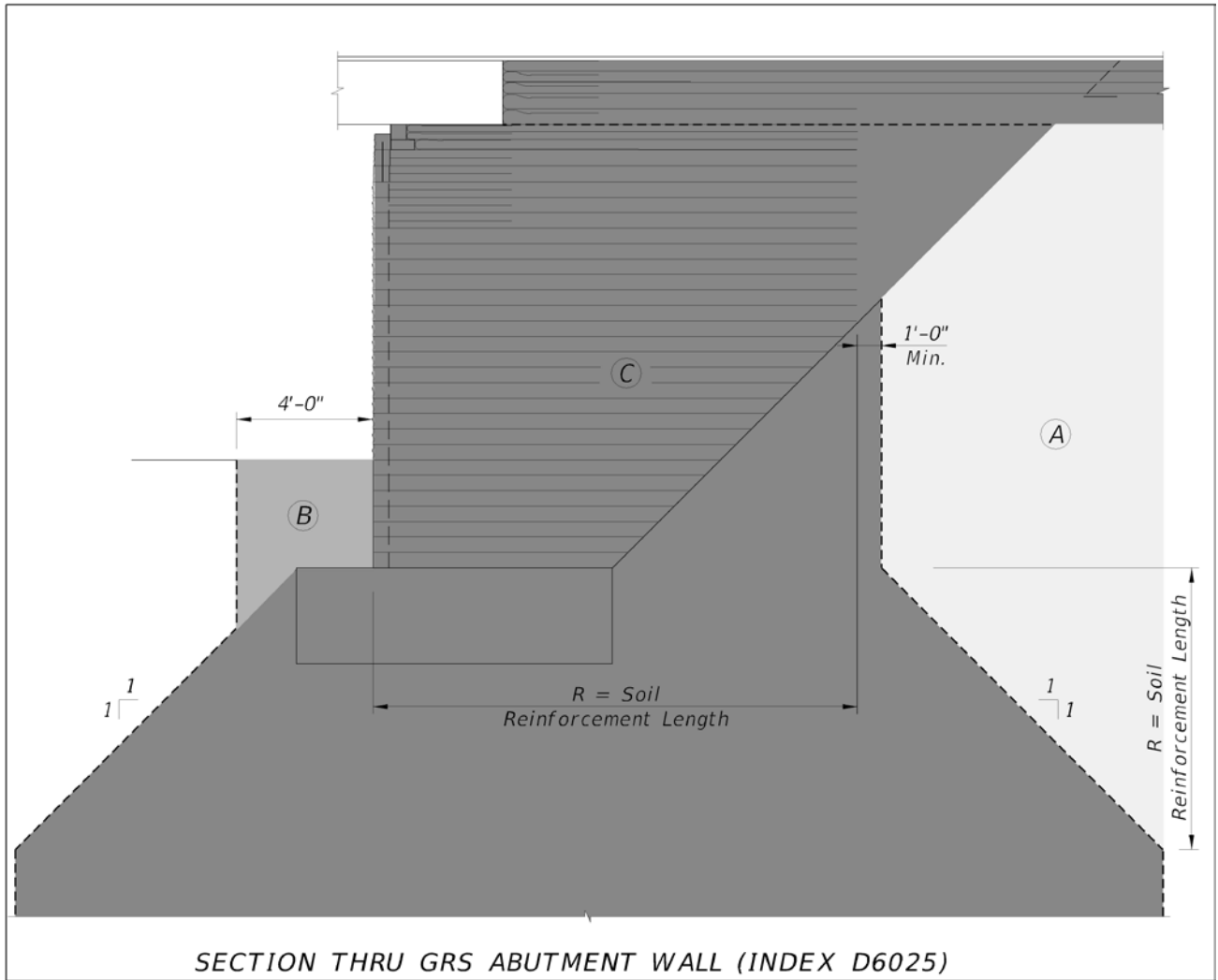

Figure F-4

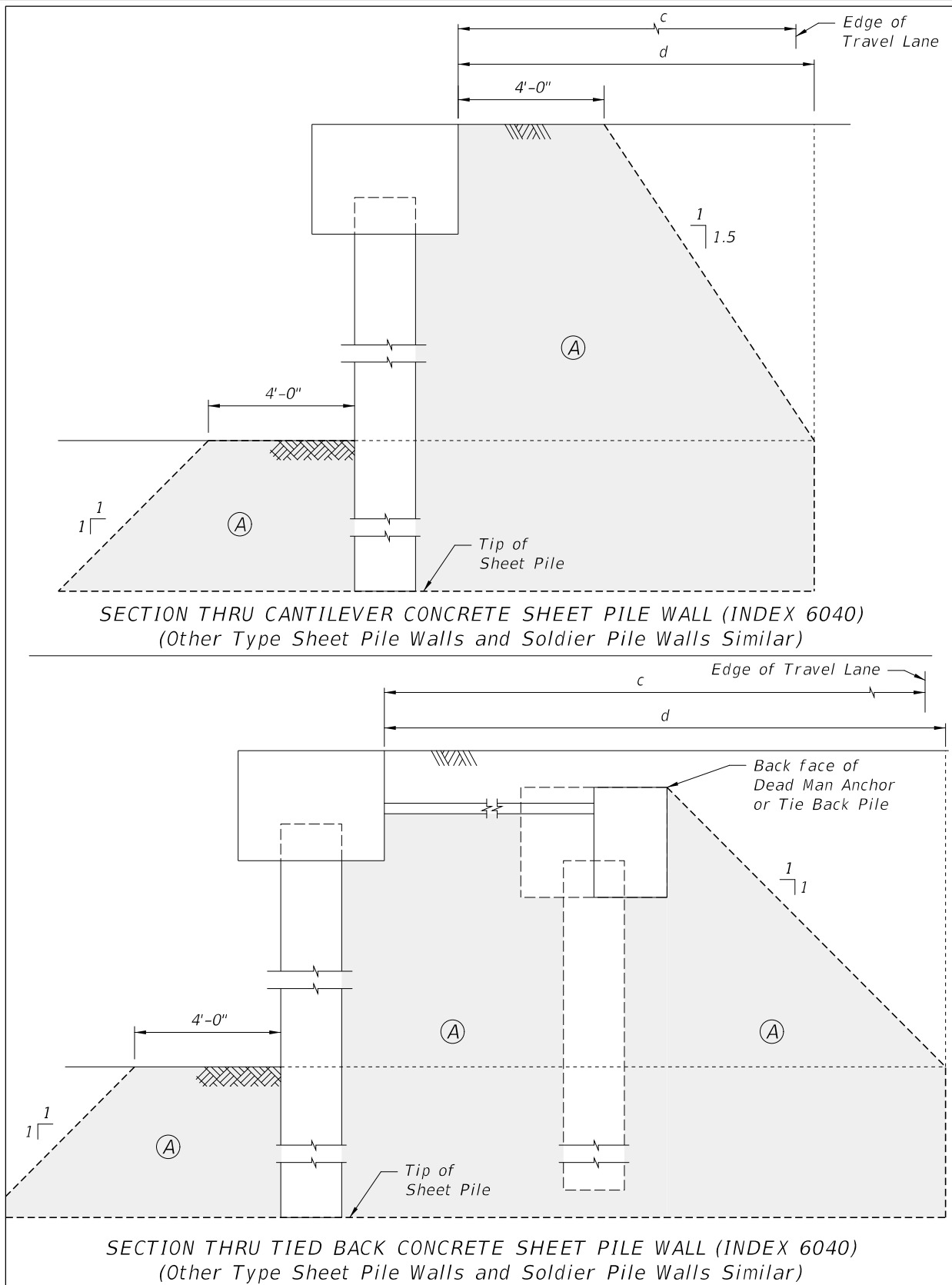

Figure F-5

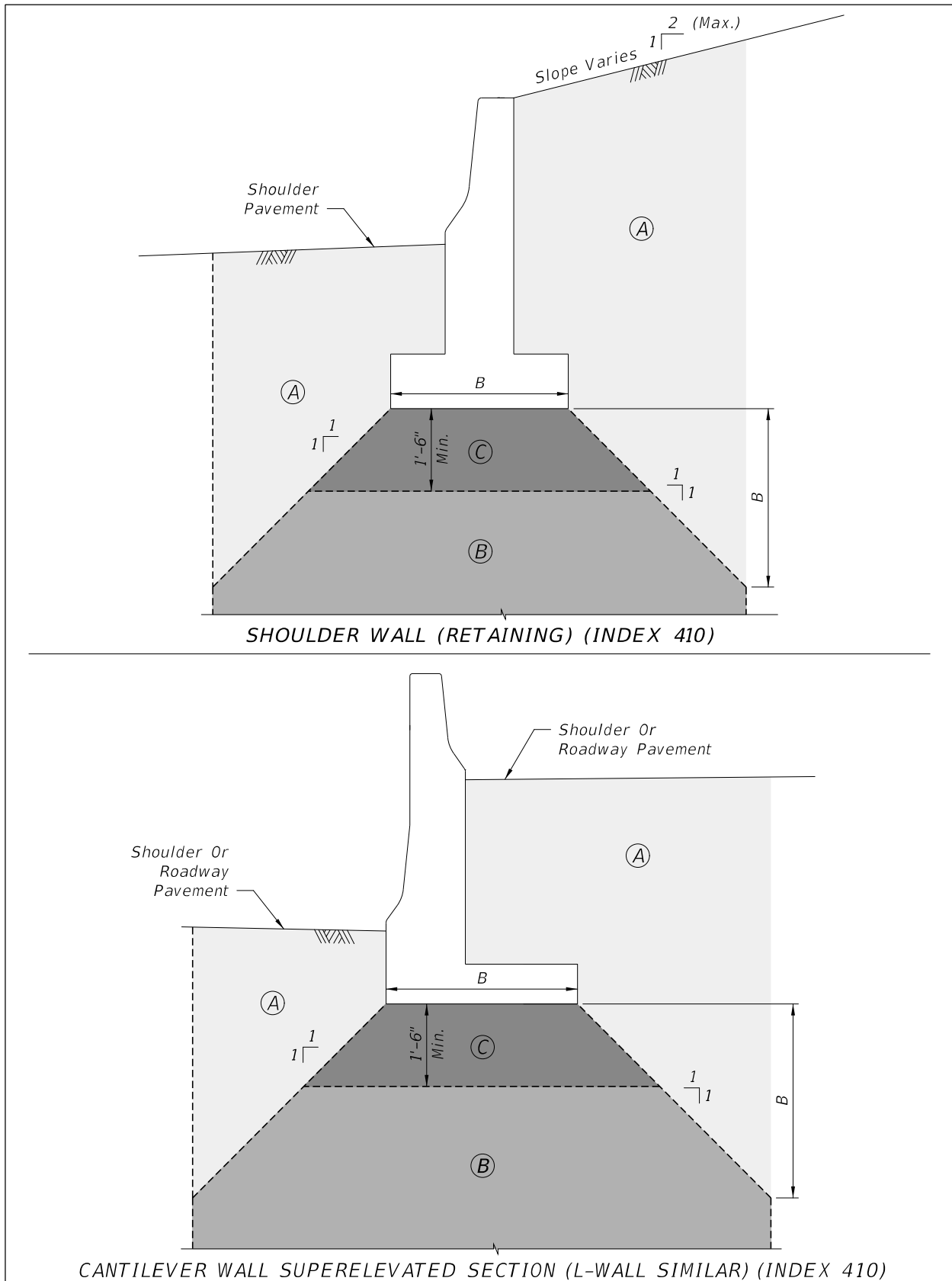

Figure F-6