

STATE OF FLORIDA DEPARTMENT OF TRANSPORTATION

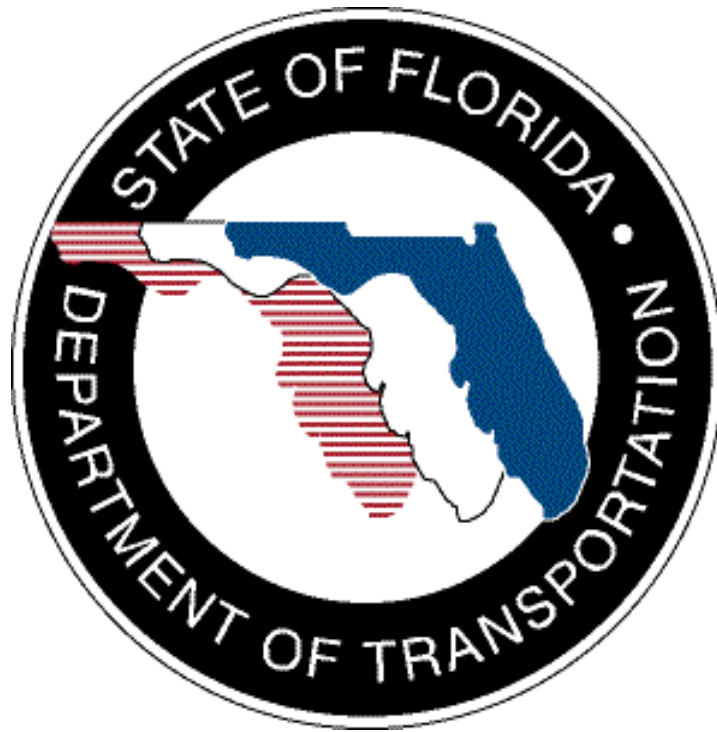

**STATE OF FLORIDA
DEPARTMENT OF TRANSPORTATION**

DRAINAGE MANUAL

**OFFICE OF DESIGN, DRAINAGE SECTION JANUARY 2013
TALLAHASSEE, FLORIDA**

TABLE OF CONTENTS

Chapter 1 Introduction.....	4
1.1 Purpose.....	4
1.2 Authority.....	4
1.3 Scope.....	4
1.4 General.....	4
1.5 Appendices.....	5
1.6 Distribution.....	5
1.7 Procedure for Revisions and Updates.....	5
1.8 Training.....	6
1.9 Forms Access.....	6
Chapter 2 Open Channel.....	7
2.1 Introduction.....	7
2.2 Design Frequency.....	7
2.3 Hydrologic Analysis.....	7
2.4 Hydraulic Analysis.....	8
2.4.1 Manning's n Values.....	8
2.4.2 Slope.....	8
2.4.3 Channel Linings and Velocity.....	8
2.4.4 Channel Bottom.....	10
2.4.5 Channel Freeboard.....	10
2.5 Construction and Maintenance Considerations.....	10
2.6 Safety.....	10
2.6.1 Protective Treatment.....	10
2.6.2 Roadside Safety.....	11
2.7 Documentation.....	11
Chapter 3 Storm Drain Hydrology and Hydraulics.....	15
3.1 Introduction.....	15
3.2 Pipe Materials.....	15
3.3 Design Frequency.....	15
3.4 Design Tailwater.....	16
3.5 Hydrologic Analysis.....	17
3.5.1 Time of Concentration.....	17
3.6 Hydraulic Analysis.....	17
3.6.1 Pipe Slopes.....	17
3.6.2 Hydraulic Gradient.....	17
3.6.3 Outlet Velocity.....	18
3.6.4 Manning's Roughness Coefficients.....	18
3.7 Hydraulic Openings.....	19

3.7.1	Entrance Location and Spacing	19
3.7.2	Manholes	20
3.7.3	Shoulder Gutter	20
3.8	Grades	21
3.8.1	Longitudinal Gutter Grade.....	21
3.9	Spread Standards	21
3.9.1	Spread for Permanent Construction.....	21
3.9.2	Spread for Temporary Construction.....	21
3.10	Construction and Maintenance Considerations.....	22
3.10.1	Pipe Size and Length.....	22
3.10.2	Minimum Clearances	23
3.11	Additional Design Considerations	24
3.11.1	MSE Walls	24
3.11.2	French Drains	25
3.11.3	Resilient Connectors	25
3.12	Protective Treatment.....	26
3.13	Documentation.....	26
3.13.1	Tabulation Form.....	26
3.13.2	Other Documentation.....	26
Chapter 4	Cross Drain Hydraulics	30
4.1	Introduction	30
4.2	General	30
4.2.2	LRFD Design Code Bridge Design Specifications.....	31
4.3	Design Frequency	31
4.3.1	Permanent Facilities	31
4.3.2	Temporary Facilities.....	31
4.4	Backwater	32
4.5	Tailwater	32
4.6	Clearances.....	33
4.7	Hydrologic Analysis.....	33
4.7.1	Freshwater Flow	33
4.7.2	Tidal Flow.....	33
4.8	Hydraulic Analysis.....	34
4.8.1	Riverine Crossings.....	34
4.8.2	Tidal Crossings	34
4.9	Specific Standards Relating to Bridges	35
4.9.1	Berms for Spill-Through Abutment Bridges.....	35
4.9.2	Scour Estimates.....	35
4.9.3	Scour Protection Considerations.....	38
4.9.4	Bridge Deck Drainage.....	39
4.9.5	Wave and Current Forces on Coastal Bridges.....	40
4.10	Specific Standards Relating to all Cross Drains Except Bridges ...	40

4.10.1	Culvert Materials	40
4.10.2	Manning's Roughness Coefficients	41
4.10.3	End Treatment	42
4.10.4	Construction and Maintenance Considerations.....	42
4.11	Documentation	43
4.11.1	Culverts (all culverts less than a 20' bridge culvert)	43
4.11.2	Bridges.....	44
4.11.3	Document Processing.....	47
Chapter 5	Stormwater Management	49
5.1	Introduction	49
5.2	Regulatory Requirements	49
5.2.1	Chapter 14-86, Florida Administrative Code	49
5.2.3	Chapter 62-25, Florida Administrative Code	49
5.2.4	Chapter 62-40, Florida Administrative Code	49
5.2.5	National Pollutant Discharge Elimination System	50
5.3	Design Standards.....	50
5.3.1	Design of Systems	50
5.3.2	Hydrologic Methods	52
5.3.3	Protective Treatment.....	52
5.3.4	Construction and Maintenance Considerations.....	52
5.4	Documentation.....	53
Chapter 6	Optional Culvert Materials	56
6.1	Introduction	57
6.2	Durability	57
6.2.1	Culvert Service Life Estimation	58
6.3	Structural Evaluation	58
6.4	Hydraulic Evaluations.....	58
6.5	Culvert Material Types	59
6.6	Jack and Bore	59
6.7	Documentation.....	60
Appendix A	: 23 CFR 650 A	63
Appendix B	: IDF Curves, Precipitation Data, Rainfall Distributions	63
Appendix C	: Drainage Law.....	64
Appendix D	: Acquisition of Real Property Rights	80

Chapter 1

Introduction

1.1 Purpose

The **Drainage Manual** sets forth drainage design standards for Florida Department of Transportation (FDOT) projects.

1.2 Authority

Chapter 334, **Florida Statute (F.S.)** Sections 20.23(4)(a) and 334.048(3), **Florida Statutes (F.S.)**

1.3 Scope

The principal users of this **Manual** are consultants and FDOT personnel who prepare FDOT construction plans.

1.4 General

Chapter 334, F.S., known as the **Florida Transportation Code**, establishes the responsibilities of the State, counties, and municipalities for the planning and development of the transportation systems serving the people of Florida, with the objective of assuring development of an integrated, balanced statewide system. The Code's purpose is to protect the safety and general welfare of the people of the State and to preserve and improve all transportation facilities in Florida. Under **Section 334.044, F.S.**, the **Code** sets forth the powers and duties of the Department of Transportation to develop and adopt uniform minimum standards and criteria for the design, construction, maintenance, and operation of public roads.

The standards in this **Manual** provide a basis for uniform design practice for typical roadway drainage design situations. Realizing that drainage design is primarily a matter of sound application of good engineering judgment, it is impossible to give precise rules which would apply to all possible situations that may arise. Situations will exist where these standards will not apply. THE INAPPROPRIATE USE OF AND/OR ADHERENCE TO THESE STANDARDS DOES NOT EXEMPT THE ENGINEER FROM THE PROFESSIONAL RESPONSIBILITY OF DEVELOPING AN APPROPRIATE DESIGN. The engineer is responsible for identifying those standards that do not apply to a particular design, and to obtain approval to deviate from those standards. Deviation from a standard in this **Manual** must be approved by the District Drainage Engineer. The request for deviation shall include the engineering justification.

1.5 Appendices

Included with this *Manual* are four appendices:

Appendix A has a link to **23 CFR 650A**. This document prescribes the Federal Highway Administration (FHWA) policies and procedures for the location and hydraulic design of highway encroachments on flood plains. It replaces **FHPM 6-7-3(2)** which was dropped when FHWA eliminated the **Federal-Aid Highway Program Manual (FHPM)**. The **FHPM** has been replaced by the **Federal Aid Policy Guide**, which closely follows the **Code of Federal Regulations**. **23 CFR 650A** has essentially the same language and requirements as old **FHPM 6-7-3(2)**. While the standards presented in the FDOT **Drainage Manual** conform to Federal requirements, drainage designers are advised to become familiar with **23 CFR 650A** to develop a basic understanding of some of the design standards for cross drains and bridges.

Appendix B has a link to the FDOT intensity-duration-frequency curves, the precipitation data, and the FDOT rainfall distributions.

Appendix C contains a general overview of drainage law with discussion of case histories in Florida. It is provided as an appendix rather than a chapter since it is primarily informational and does not constitute a standard.

Appendix D contains guidance on general FDOT practice with regard to acquisition of drainage easements, flood rights, etc. In addition, a discussion on protective treatment considerations in drainage design is provided. As with the appendix on **Drainage Law**, it is provided as an appendix rather than a chapter since the material should primarily be used as guidance, and not as minimum standards.

1.6 Distribution

This *Manual* is available for downloading from:

<http://www.dot.state.fl.us/rddesign/dr/files/DrainageManual.pdf>

1.7 Procedure for Revisions and Updates

Comments and suggestions for changes to the *Manual* can be submitted by e-mailing the [State Drainage Engineer](#). Appropriate Roadway Design or Drainage Design staff will review each idea or suggestion received in a timely manner.

Statewide meetings of the District Drainage Engineers and the State Drainage Engineer are held at least annually and teleconferences are held monthly. A major agenda item

at these meetings will be the review of planned revisions, and suggestions and comments that may warrant revisions. Based on input from these meetings, official proposed revisions are developed.

The State Drainage Engineer will coordinate the proposed revisions with all the affected offices and with FHWA. Official adoption of the proposed revisions is made by State Drainage Engineer with input from the District Drainage Engineers.

Prior to release, all revisions will be coordinated with the Forms and Procedures Office to ensure conformance with and incorporation into the Department's ***Standard Operating System***.

Approved revisions will be available on-line. Revisions made to individual pages will have a revision date in the header.

1.8 Training

There is no mandatory training required.

1.9 Forms Access

There are no forms related to this ***Manual***.

Chapter 2

Open Channel

2.1 Introduction

This chapter presents standards for the design of artificial or manmade open channels, including roadside ditches, median ditches, interceptor ditches, outfall ditches, and canals.

2.2 Design Frequency

Open channels shall be designed to convey, without damage, and to confine within the ditch, stormwater flow with standard design frequencies as follows:

TYPE CHANNEL	FREQUENCY
Roadside, Median, and Interceptor ditches or swales	10-year
Outfall ditches	25-year
Canals	25-year
Temporary roadside and median ditches or swales	2-year
Temporary Outfalls and Canals	5-year

Site-specific factors may warrant the use of an atypical design frequency. Designs based on frequencies other than listed above shall be supported by a risk assessment or analysis, as appropriate. Any increase over pre-development stages shall not significantly change land use values, unless flood rights are acquired. The acquisition of flood rights shall be based on a risk analysis to select the least total expected cost design.

2.3 Hydrologic Analysis

Hydrologic data used for the design of open channels shall be based on one of the following methods as appropriate for the particular site:

1. A frequency analysis of observed (gage) data shall be used when available.

-
- If insufficient or no observed data is available, one of the procedures below shall be used as appropriate. However, the procedures below shall be calibrated to the extent practical with available observed data for the drainage basin, or nearby similar drainage basins.
- a. Regional or local regression equation developed by the USGS.
 - b. Rational Equation for drainage areas up to 600 acres.
 - c. For outfalls from stormwater management facilities, the method used for the design of the stormwater management facility may be used. See **Chapter 5** for hydrologic methods that may be used for the design of stormwater management facilities.
2. For regulated or controlled canals, hydrologic data shall be requested from the controlling entity. Prior to use for design, this data shall be verified to the extent practical.

2.4 Hydraulic Analysis

The Manning's Equation shall be used for the design of open channels.

2.4.1 Manning's n Values

Recommended Manning's n values for channels with bare soil and vegetative linings are presented in **Table 2.1**. Manning's n values for rigid linings are presented in **Table 2.2**.

The probable condition of the channel when the design event is anticipated shall be considered when a Manning's n value is selected. Ditches with bottoms designed at or near the seasonal high groundwater level should consider the use of higher n values to account for increased vegetation growth occurring between extended maintenance periods.

2.4.2 Slope

For ditches where positive flow conditions are required a minimum physical slope of 0.0005 ft/ft shall be used.

2.4.3 Channel Linings and Velocity

The design of open channels shall consider the need for channel linings. Standard lining types are shown in **Design Standard Indexes 199 and 281**. Maximum velocities for the various forms of channel lining are given in **Tables 2.3 and 2.4**. When design

flow velocities do not exceed the maximum permissible for bare earth as given in **Table 2.3**, standard treatment of ditches consists of grassing and mulching. For higher design velocities, sodding, ditch paving, or other form of lining consistent with **Tables 2.3** and **2.4** shall be provided.

Shear stress shall be checked at locations of steep slopes (>1%) such as ditch flow down a pond slope, gore drainage, and offsite flow entering the right of way via the back slope of a roadside swale.

2.4.3.1 Limitations on Use of Linings

2.4.3.1.1 Grassing and Sodding

Grassing or sodding should not be used under the following conditions:

1. Continuous standing or flowing water
2. Areas that do not receive the regular maintenance necessary to prevent domination by taller vegetation
3. Lack of nutrients and excessive soil drainage
4. Areas excessively shaded

2.4.3.1.2 Concrete Lining

To prevent cracking or failure, concrete lining must be placed on a firm, well-drained foundation. Concrete linings are not recommended where expansive clays are present.

When concrete linings are to be used where soils may become saturated, the potential for buoyancy shall be considered. Acceptable countermeasures include:

1. Increasing the thickness of the lining to add additional weight.
2. For sub-critical flow conditions, specifying weep holes at appropriate intervals in the channel bottom to relieve the upward pressure on the channel.
3. For super-critical flow conditions, using subdrains in lieu of weep holes.

2.4.3.1.3 Asphalt Linings

Asphalt linings are intended for maintenance activities only.

2.4.4 Channel Bottom

The preferred channel bottom width is 5 ft to accommodate mitered end sections and maintenance mowers. V-bottom ditches should be avoided where practical due to their vulnerability to fill with silt.

Where possible, the minimum ditch bottom elevation should be 1 ft above the estimated seasonal high groundwater elevation for maintainability.

2.4.5 Channel Freeboard

If a channel is hydraulically connected to or part of the storm water management facility, a 1 ft freeboard is required above the peak design stage.

2.5 Construction and Maintenance Considerations

The design of an open channel shall be consistent with the standard construction and maintenance practices of the Department. Standard ditch linings are detailed in the ***Design Standard Index*** drawings. In the event the standard index drawings are not suitable for a specific project need, a detailed design shall be developed. This information must be specified in the design documents.

Ditches, outfall ditches retention/detention areas, and other drainage related features must be provided with berms and other physical access devices that facilitate maintenance activities. Consideration shall be given to future expansion of the facilities and to possible increased maintenance requirements. Absolute minimum values should only be used in extremely stable areas, in areas requiring infrequent maintenance, or in areas where existing physical constraints require their use. Berms should be based at the narrowest point; right-of-way should be reasonably uniform. If double ditches are specified, the berm width between the two ditches should be 10 ft minimum for maintenance access. The berm width should be 15 ft if the ditches are wet. Contact the local maintenance office for minimum access requirements when a 10 ft berm is not feasible.

2.6 Safety

2.6.1 Protective Treatment

Drainage designs shall be reviewed to determine if some form of protective treatment will be required to prevent entry to facilities that present a hazard to children and, to a lesser extent, all persons. General guidance is provided in ***Appendix D***. Protective treatment for open channels in the form of fencing shall be considered when a potential

hazard exists.

2.6.2 Roadside Safety

The design and location of open channels shall comply with roadside safety and clear zone requirements. See the *Plans Preparation Manual* for clear zone requirements, including special clearance criteria for canals.

2.7 Documentation

Design documentation for open channels shall include the hydrologic analysis and the hydraulic analysis, including analysis of channel lining requirements. For roadside ditches, the standard format for documentation is provided in *Figure 2-1*.

Table 2.1

Recommended Manning's n Values for Artificial Channels
 with Bare Soil and Vegetative Linings

<u>Channel Lining</u>	<u>Description</u>	<u>Design n Value</u>
Bare Earth, Fairly Uniform	Clean, recently completed	0.022
Bare Earth, Fairly Uniform	Short grass and some weeds	0.028
Dragline Excavated	No Vegetation	0.030
Dragline Excavated	Light Brush	0.040
Channels not Maintained	Dense weeds to flow depth	0.10
Channels not Maintained	Clear bottom, brush sides	0.08
Maintained Grass or Sodded Ditches	Good stand, well maintained 2 - 6"	0.06*
Maintained Grass or Sodded Ditches	Fair stand, length 12" - 24"	0.20*

* Decrease 30 per cent for flows > 0.7' depth (max flow depth 1.5')

Table 2.2
 Recommended Manning's n Values for Artificial Channels
 with Rigid Linings

<u>Channel Lining</u>	<u>Description</u>	<u>Design n Value</u>
Concrete Paved	Broomed*	0.016
Concrete Paved	"Roughened" - Standard	0.020
Concrete Paved	Gunite	0.020
Concrete Paved	Over Rubble	0.023
Rubble Riprap	Ditch Lining	0.035
Asphalt Concrete	Smooth	0.013
Asphalt Concrete	Rough	0.016

* This is not the standard finish and must be specified when used (see **Section 524-7** of **Standard Specifications**)

Table 2.3
 Maximum Shear Stress Values
 and Allowable Velocities for Different Soils

<u>Soil Type</u>	<u>Shear Stress (psf)</u>	<u>Allowable Velocity for a flow depth of about 3 ft. (fps)</u>
Silt or Fine Sand	0.027	1.50
Sandy Loam	0.037	1.75
Silt Loam	0.048	2.00
Firm Loam	0.075	2.50
Stiff Clay	0.260	3.75
Hardpans	0.670	6.00

Reference: University of Florida (1972)

Table 2.4
 Maximum Velocities for Various Lining Types

<u>Lining Type</u>	<u>Maximum Velocity (fps)</u>
Grass with Mulch	Bare Soil (Table 2.3)
Sod	4
Staked Sod	5
Lapped Sod	5.5
Erosion Control Blanket (Biodegradable, Spec Section 104-6)	6.5
Plastic Erosion Mat (Permanent, Index 199, Spec Section 571)	
- Type 1	10
- Type 2	14
- Type 3	18
Riprap (Rubble)(Ditch Lining)	6
Other flexible	FHWA HEC-15
Geotextile Grid	4 - 8*
Rigid	10**

* Varies with grid

** Higher velocities acceptable with provisions for energy dissipation

FLORIDA DEPARTMENT OF TRANSPORTATION
 HYDRAULIC WORKSHEET FOR ROADSIDE DITCHES

Road: _____
 Project Number: _____

Sheet _____ of _____
 Prepared by: _____ Date: _____
 Checked by: _____ Date: _____

STATION TO STATION	SIDE	% Slope	Drain Area	"C"	t _c	i ₁₀	Q (cfs)	Ditch Section			"n"	"d"	Vel. (fps)	Ditch Lining	Side Drain Pipe Dia.	Remarks
								F.S.	B.W.	B.S.						

Note: F.S. = Front Slope

B.W. = Bottom Width

B.S. = Back Slope

Figure 2-1

Chapter 3

Storm Drain Hydrology and Hydraulics

3.1 Introduction

This chapter presents minimum standards for the design of FDOT storm drain systems.

3.2 Pipe Materials

Pipe material selection shall be in accordance with **Chapter 6** of this **Manual**.

3.3 Design Frequency

Standard design storm frequencies for the design of storm drain systems are as follows:

TYPE STORM DRAIN	FREQUENCY
General design	3-year
General design work that involves replacement of a roadside ditch with a pipe system by extending side drain pipes.	10-year
General design on work to Interstate Facilities	10-year
Interstate Facilities for sag vertical curves which have no outlet other than a storm drain system, and for the outlet of systems requiring pumping stations	50-year

Site-specific factors may warrant the use of a higher design frequency. Designs based on frequencies other than listed above shall be supported by a risk assessment or analysis, as appropriate. Any increase over pre-development stages shall not significantly change land use values, unless flood rights are acquired. The acquisition of flood rights shall be based on a risk analysis to select the least total expected cost design.

If a system has both curb inlets and ditch bottom inlets (DBI's), the HGL for the DBI's should be checked for a 10-year Design Frequency and all structures in the mixed

system should meet the 3-year Design Frequency.

3.4 Design Tailwater

For the determination of hydraulic gradient and the sizing of storm drain conduits a tailwater elevation, which can be reasonably expected to occur coincident with the design storm event shall be used. Standard design tailwater conditions for the design of storm drain systems are as follows:

Crown of pipe at the outlet, or if higher:

Lakes -----	Normal High Water
Rivers and Streams --	Normal High Water
Stormwater Ponds ----	Peak stage in the pond during the storm drain design event. See Chapter 5 for routing requirements.
Tidal Bays -----	Mean High Tide
Ditches Free flowing --	Normal depth flow in the ditch at the storm drain outlet for the storm drain design storm event. (May differ from ditch design storm event.)
Downstream control --	The higher of: the stage due to free flow conditions (described above) or, the maximum stage at the storm drain outlet due to backwater from the downstream control using flows from the storm drain design storm event.
Existing Systems -----	Elevation of hydraulic grade line of the system at the connection for the design storm event
French Drains -----	Design Head over the outlet control structure
Closed Basin -----	Varies, depending on site specific conditions
Regulated Canals -----	Agency regulated control elevation

3.5 Hydrologic Analysis

The Department requires use of the Rational Method for performing hydrologic calculations for storm drains.

3.5.1 Time of Concentration

A minimum time of concentration of 10 minutes shall be used.

3.6 Hydraulic Analysis

Hydraulic calculations for determining storm drain conduit sizes shall be based on open channel and pressure flow as appropriate. The Manning's equation shall be used.

3.6.1 Pipe Slopes

The physical slope shall be that which will produce a velocity of at least 2.5 ft per second (fps) when the storm drain is flowing full. In areas of flat terrain where 2.5 fps is not feasible, an absolute minimum velocity of 2 fps for full flow shall be obtained.

For pressure flow stormsewer systems the minimum physical slope shall be 0.1%.

3.6.2 Hydraulic Gradient

Friction losses shall be considered in the computation of the design hydraulic gradient for all storm drain systems. Energy losses associated with special pollution control structures (weirs, baffles, etc.) and due to utility conflict structures shall also be considered for all storm drain systems when present in the system.

When hydraulic calculations consider only the major losses such as those described above and do not consider all minor energy losses, the elevation of the hydraulic gradient for design storm conditions shall be at least 1 ft below the theoretical gutter elevation (1.13' below the edge of pavement for Type E or F Curb). This does not apply to ditch bottom inlets and other similar conditions where temporary ponding or overload is not objectionable. However, any increase over pre-development stages shall not significantly change land use values, unless flood rights are acquired. The acquisition of flood rights shall be based on a risk analysis to select the least total expected cost design.

If all major and minor energy losses are calculated, it is acceptable for the hydraulic gradient to reach the gutter elevation. Minor losses include: entrance, exit, junction and manhole, expansion, contraction, and bend.

Minor losses shall be considered when velocity approach 8 fps.

3.6.3 Outlet Velocity

When the outlet velocity for the design storm discharge exceeds 4 fps, the need for special channel lining (revetment or armoring) and/or energy dissipation shall be considered for protection against undesirable scour. For computation of the outlet velocity, the lowest anticipated tailwater condition that can be reasonably expected to occur during a storm event shall be assumed.

In areas where turf sustainability may be an issue, coordinate with maintenance to determine appropriate channel lining material.

3.6.4 Manning's Roughness Coefficients

Values for Manning's roughness coefficient are as follows:

Concrete Box Culverts	n = 0.012
Concrete Pipes	n = 0.012

Metal Pipes:

Pipe and Pipe Arch - Helical Fabrication	
Re-corrugated Ends - All Flow Conditions*	
12" to 24"	n = 0.020
30" to 54"	n = 0.022
60" and larger	n = 0.024

Pipe and Pipe Arch - Spiral Rib Fabrication	
Re-corrugated Ends - All Flow Conditions*	
All Sizes	n = 0.012

Plastic Pipes:

Polyvinyl Chloride-PVC (external rib/smooth interior)	
All Sizes	n = 0.012
Polyethylene (All Sizes)	
Single Wall	n = 0.024
Double Wall (Smooth)	n = 0.012
Polypropylene (All Sizes)	
Single Wall	n = 0.024
Double & Triple Wall (Smooth)	n = 0.012

* "Spiral" flow will not occur for most design situations. Therefore "spiral" flow design values have not been established. Values recommended by the Southeast Corrugated Steel Pipe Association are contained in the *AISI Handbook of Steel Drainage & Highway Construction Products*.

3.7 Hydraulic Openings

Inlets and other hydraulic structures shall be selected/designed to satisfy hydraulic capacity, structural capacity, safety (vehicular, pedestrian, cyclist) and durability requirements.

Alternate "G" (hot dipped galvanized) grates and frames shall be required when the structure is located on any barrier island, the Florida Keys, or within ½ mile of any body of brackish water containing chlorides > 2000 ppm.

General guidance on protective treatment is discussed in *Appendix D*.

3.7.1 Entrance Location and Spacing

3.7.1.1 Inlets

Inlet type, location and spacing shall consider the following:

1. Inlet capacity and width of spread.
2. Movement of vehicles to and from adjacent property on turnouts.
3. Pedestrian and Bicycle Safety
4. Maximum pipe length without maintenance access (*Section 3.10.1*)
5. Roadway Geometry
6. Hydraulic efficiency of the system
7. Potential for flooding of off-site property
8. Potential for low points at turn lanes and bus bays
9. Maintenance accessibility

Inlets shall be placed at all low points in the gutter grade and/or ditch, and as appropriate at intersections, median breaks, and on side streets where drainage would adversely flow onto the highway pavement.

For inlets on a continuous grade, a maximum spacing of 300 ft shall be used unless spread calculations indicate greater spacing is acceptable. Spread standards are provided below in *Section 3.9*.

Inlets shall also be placed at the critical section prior to the level section in superelevation transitions, to avoid concentrated flows across the pavement.

Curb inlets, including inlet transitions shall not be located within handicap drop curb locations. The use of inlets on returns shall be justified and documented.

Inlets in sag vertical curves that have no outlet other than the storm drain system and do not have open throats, should have flanking inlets on one or both sides. These flanking inlets should be located to satisfy spread criteria when the sag inlet is blocked. Even with an open throat inlet, flanking inlets should be considered when the minimum gutter grade cannot be met.

Parking lot drainage shall consider the following:

1. Curb inlets are not to be used in areas of heavy pedestrian traffic; specifically service plaza parking lots. One option is to use ditch bottom inlets with pedestrian rated grates.
2. Ditch bottom inlets should be placed in the center of the travel lanes and not in hidden locations such as parking spaces.
3. Parking lots should be graded away from the heaviest pedestrian areas to more remote locations where the ditch bottom inlets should be placed. Another option is to place cuts in the curb allowing pavement to drain into grassed swales prior to entering ditch bottom inlets.

3.7.2 Manholes

Manholes should be placed outside of the wheel path of vehicles.

3.7.3 Shoulder Gutter

Shoulder gutter is required on embankment higher than 20 ft (6.1 m) and on embankment higher than 10 ft where the longitudinal slope is greater than 2 percent, see the *Plans Preparation Manual* for standard slopes. Shoulder gutter limits will match guardrail limits at a minimum, where embankment slopes are steeper than 1:4.

Shoulder gutter is preferred on interchange and grade separation embankments higher than 5 ft (1.5 m) with slopes steeper than 1:6 to minimize erosion. Shoulder gutter is also required at bridge ends where concentrated flow from the bridge deck would otherwise run down the fill slope. Shoulder gutter is preferred on the high side of superelevated sections, in areas of guardrail, to minimize erosion, when any part the paved shoulder slopes away from the roadway pavement. Shoulder gutter is required on high side if landscaping of the embankment is proposed.

Shoulder gutter is not required adjacent to barrier walls, unless justified.

Special profiles shall be developed in areas of cross slope transitions and at roadway-bridge interfaces to see that storm water is properly drained and not trapped.

3.8 Grades

3.8.1 Longitudinal Gutter Grade

The minimum longitudinal gutter grade is 0.3 per cent.

3.9 Spread Standards

3.9.1 Spread for Permanent Construction

The spread resulting from a rainfall intensity of 4.0 inches per hour shall be limited as follows.

Typical Section Condition	Design Speed (mph)	Spread Criteria*
Parking Lane or Full Width Shoulders	All	No encroachment
All Other	Design speed \leq 45	Keep $\frac{1}{2}$ of lane clear
	45 < Design Speed \leq 55	Keep 8' of lane clear
	Design Speed > 55	No encroachment

* The criteria in this column apply to travel, turn, or auxiliary lanes adjacent to barrier wall or curb, in normal or super elevated sections.

In addition to the above standards, for sections with a shoulder gutter, the spread resulting from a 10-year frequency storm shall not exceed 1' 3" outside the gutter in the direction toward the front slope. This distance limits the spread to the face of guardrail posts. See **Figure 3-2**.

3.9.2 Spread for Temporary Construction

Design temporary drainage, for traffic diversions and construction staging, to provide

drainage where construction activities might divert or trap water and compromise safety and efficiency.

Additional attention shall be given to expected spread for areas that are:

1. Flood sensitive,
2. High speed facilities (> 55 mph posted speed)
3. Using low side barrier wall.

3.10 Construction and Maintenance Considerations

The design of storm drain systems shall be consistent with the standard construction and maintenance practices of the Department. Standard details for inlets, manholes, junction boxes, end treatments, and other miscellaneous drainage details are provided in the ***Design Standard Index*** drawings. Specifications are provided in the ***Standard Specifications for Road and Bridge Construction***. In the event standard index drawings are not suitable for a specific project need, a detailed design shall be developed and included in the plans; and, as appropriate, special provisions shall be provided for inclusion with the project specifications. Proper design shall also consider maintenance concerns of adequate physical access for cleaning and repair.

Pipe junctions without an access structure should be avoided (i.e. two pipes joining at 90°). Drainage structures with weirs should have a manhole on each side of the weir. Consider providing a 2 piece, 3 ft. diameter, manhole cover for maintenance access.

Outfall structures and structures with pollution retardant baffles or skimmers installed inside the structure are required to have a 4 ft minimum sump. When 2 or more baffles or skimmers are used in the same structure, a minimum horizontal distance of 2.5 ft shall be provided between baffles, for maintenance access. For submerged systems, where cleanout velocity is not maintained, consider a 2 ft sump for all affected inlets.

For urban roadways with significant leaf drop potential and posted speed limit 40 mph or less, consider using a curb inlet screens to keep debris out of storm sewer system. It is recommended to use a catch basin pipe connection screen in conjunction with curb inlet screens.

3.10.1 Pipe Size and Length

The minimum pipe size for trunk lines and laterals is 18". The minimum pipe diameter for all proposed exfiltration trench pipes (French drain) is 24".

The 18" minimum pipe size does not apply to connections from stormwater management facilities. The pipe size for these connections shall be the size required to

convey the permitted discharge.

The maximum pipe lengths without maintenance access structures are as follows:

Pipes without French Drains:

18" pipe	300 ft
24" to 36" pipe	400 ft
42" and larger and all box culverts	500 ft

French Drains that have access through only one end:

24" to 30" pipe	150 ft
36" and larger pipe	200 ft

French Drains that have access through both ends:

24" to 30" pipe	300 ft
36" and larger pipe	400 ft

3.10.2 Minimum Clearances

The following minimum clearances shall be provided:

1. The minimum clearance between the outside crown of a pipe and the gutter elevation at the inlet shall be in accordance with standard index drawing requirements for the specified inlet. If this cannot be achieved, a special detail shall be provided in the plans.
2. Minimum cover for pipe shall be provided in accordance with ***Index 205, Roadway and Traffic Design Standards***.
3. Storm drain systems that cross railroad tracks have special below-track clearance requirements and must use special strength pipe. See ***Standard Index No. 280*** for railroad company design requirements.
4. Utility Clearances:
 - a. When a utility crosses a storm drain alignment, the recommended minimum design clearance between the outside of the pipe and the outside of the conflict should be 0.5 ft if the utility has been accurately located at the point of conflict. If the utility has been approximately located, the minimum design clearance should be 1 ft. Utility company recommended clearances can vary from these design values, but electrical transmission lines or gas mains shall never come into direct

contact with the storm drain.

- b. Storm drain lines shall be located to not disturb existing utilities to the extent practical. If a utility conflict occurs, the District Drainage Engineer and the Utilities Section shall be contacted to review potential problems and feasible solutions.
- c. When a sanitary line or other utility, including other storm drains, must pass through a manhole, minimum clearances in accordance with ***Design Standard Index 307*** shall be provided. The head loss caused by an obstruction shall be accounted for in the computation of the design hydraulic grade line. (Note: Gas mains shall not pass through inlet and manhole structures.)
- d. Utility conflict structures should provide manholes on both sides of the conflict when the conflicting utility is large (≥ 12 "), or the conflict is close to the top of the structure. Maintenance vector trucks have a rigid suction pipe that cannot bend around obstructions. If the degree of access is uncertain, contact the local FDOT maintenance office for direction.
- e. The distance between the bottom of the utility and the conflict structure bottom should be no less than the internal diameter of the outlet pipe. Possible use of a sump should be considered in areas where sedimentation is expected. Use of a sump will require that the system be designed to account for the headloss generated if the sump is completely blocked.

3.11 Additional Design Considerations

3.11.1 MSE Walls

Avoid the placement of drainage lines through MSE walls and similar structures when possible. During the design process, review drainage line placement for conflicts with structural elements including but not limited to MSE wall soil reinforcement straps and foundations, mast arm foundations, guardrail posts, light pole foundations, etc. Drainage lines placed near structural foundations should be modeled with ground water mounding. Consult with the district geotechnical engineer regarding conflicts between foundations and drainage lines. Further details regarding the placement of drainage systems and retaining walls refer to the ***Storm Drain Handbook***.

3.11.2 French Drains

Baffles, skimmers and 4 ft minimum sumps must be provided at inlet points to minimize entrance of oil and sediments into the French drain system. Exfiltration trench may not be located where there are contaminated soils and in well field protection zones with less than 30 days travel time to potable water supply wells. French drains are not allowed in embankments/fill conditions (not natural or compacted soil material).

A minimum of 10 ft must be provided between French drains and overhead signs, drill shafts, light poles foundations or retaining walls. If this minimum distance cannot be met, the segment of perforated pipe and trench within the 10 ft of influence of the drill shaft or foundation needs to be replaced with a solid segment of pipe.

The depth and location of the French Drain trench shall be established based on prudent benefit / cost considering the following factors:

1. Depth of transmissive strata that satisfy design needs
2. Safety, feasibility, and expected frequency of required French Drain maintenance activities
3. Loss of functionality of the French Drain due to its being under impervious surfaces.
4. Location of trees, utilities, and other features that may compromise the integrity of the trench envelope.
5. The cost of providing other stormwater management infrastructure in lieu of the French Drain.
6. Cost of replacing the French Drain in the future

3.11.3 Resilient Connectors

All precast storm sewer manholes and inlets may utilize resilient connectors as specified in Chapter 430 of the ***FDOT Standard Specifications for Road and Bridge Construction***.

Resilient connectors shall not be specified or required for the following conditions:

- The interface angle of connection between the structure and pipe is greater than 15 degrees, in either the horizontal or vertical direction.
- The structure and all connections which fall outside the 1:2 roadway template control line as per ***Design Standard Index 505***.

-
- The remaining beam height of the single precast unit, from the top of that segment to the existing crown of pipe chosen, is less than 8 inches.
 - Where elliptical pipes are specified on the plans.

3.12 Protective Treatment

Drainage designs shall be reviewed to determine if some form of protective treatment will be required to prevent entry to facilities that present a hazard to children and to a lesser extent to all persons. General guidance is provided in **Appendix D**.

Grates, guards or fences shall be considered for entrances to long or submerged storm drain systems. Protection shall also be considered in systems that have partial submergence at the entrance and full submergence at locations farther along in the system.

3.13 Documentation

3.13.1 Tabulation Form

A suggested format for tabulating the results of hydrologic and hydraulic calculations for storm drain systems is presented in **Figure 3-1**. The minimum information for producing a storm tabulation form is also noted in **Figure 3-1**. A copy of the completed form shall be filed for permanent record as a part of the signed and sealed design documentation. Descriptions and examples of the form content can be found in the **Storm Drain Handbook**.

3.13.2 Other Documentation

Other supporting calculations and design documentation shall be filed, including:

1. For complex systems, a narrative describing how the storm drain system will function.
2. Hydrologic Computations:
 - a. Time of Concentration
 - b. Runoff Coefficients
3. Spread and Inlet capacity analysis, when required
4. Determination of Design Tailwater
5. Optional materials evaluation
6. Computation of minor energy losses, if applicable
7. Completed Drainage Map with drainage areas to each inlet identified, and

-
- structures numbered consistent with drainage computations and tabs.
8. Outlet scour protection analysis, if applicable.

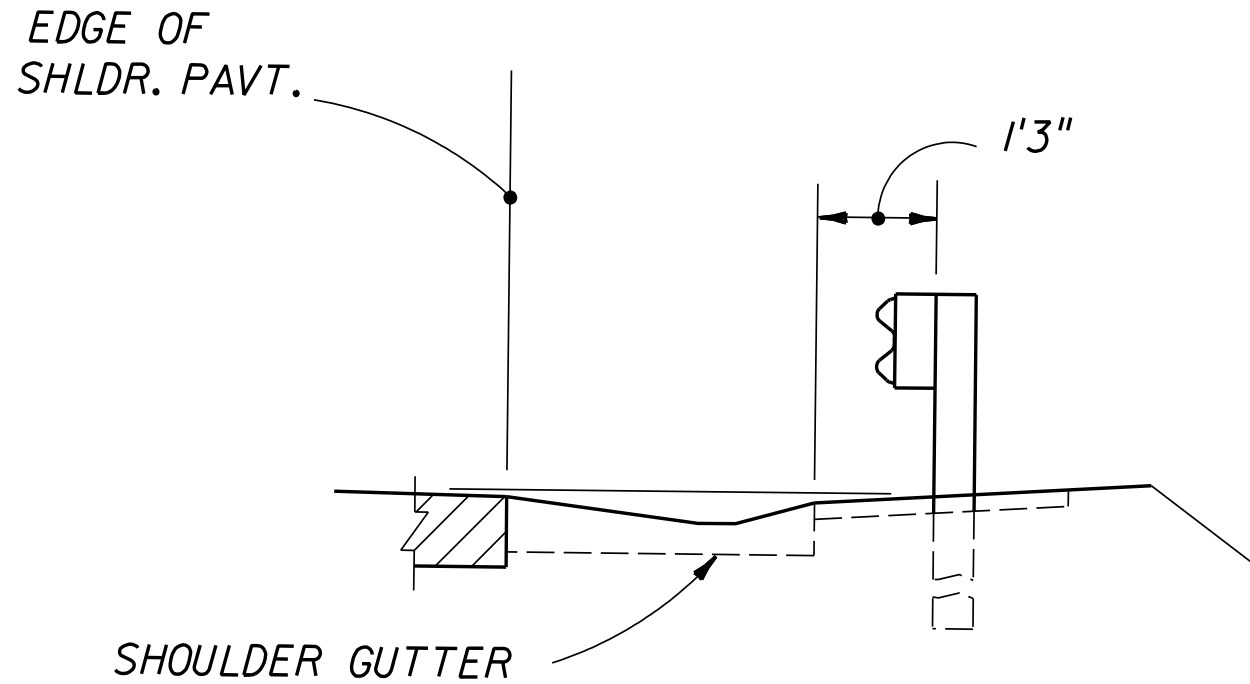

FIGURE 3-2

Chapter 4

Cross Drain Hydraulics

4.1 Introduction

This chapter presents standards and procedures for the hydraulic design of cross drains including culverts, bridge-culverts¹, and bridges. Preliminary planning and location studies for cross drains are addressed in the *FDOT Project Development and Environmental Manual*.

4.2 General

The hydraulic design of cross drains shall be done in accordance with good engineering practice and comply with **23 CFR 650**, Subpart A, and the *National Flood Insurance Program*. Specifically:

1. All cross drains shall be designed to have sufficient hydraulic capacity to convey the selected design frequency flood without damage to the structure and approach embankments, with due consideration to the effects of greater floods.
2. Bridge and bridge culvert FOUNDATIONS shall be designed with normal safety factors to withstand the worst case scour condition up through the 100-year frequency flood event, and shall have a minimum factor of safety of one against failure due to the worst case scour condition up through the 500-year frequency flood event.
3. The design of all cross drain structures shall be analyzed for the Design Flood, Base Flood (100-year frequency flood) and the Greatest Flood (overtopping flood or the 500-year frequency flood where overtopping is not practicable) that can be expected to flow to the structure. A summary of this analysis showing the peak stages and discharges for these events shall be shown on the final project plans.
4. For projects that encroach into a Regulatory Floodway, the design shall be coordinated with the appropriate local government Flood Insurance Program official.

¹ A culvert qualifies as a bridge if it meets the requirements of Item 112 in the FDOT [“Bridge Management System Coding Guide.”](#)

4.2.2 LRFD Design Code Bridge Design Specifications

LRFD Design Code Bridge Design Specifications Section 2.6 is deleted in its entirety.

4.3 Design Frequency

4.3.1 Permanent Facilities

Standard design frequencies for permanent culverts, bridge-culverts and bridges are as follows:

FACILITY	FREQUENCY
Mainline Interstate	50 years
High Use or Essential: Projected 20 year AADT* > 1500,	50 years
Other: Projected 20 year AADT* < 1500,	25 years
Roadside Ditch Culverts	10 years

* AADT preferred but if not available ADT may be utilized.

Design frequencies may be higher when justified by risk assessment or risk analysis.

Note: The flood frequencies used for scour analysis differ. See **Section 4.9.2**.

4.3.2 Temporary Facilities

Temporary traversing works shall be designed accounting for the permitted duration of the traversing work. Temporary traversing work shall cause no more than a 1 ft increase in the Design Storm Frequency (DSF) flood elevation immediately upstream and no more than one tenth of a ft increase in the DSF flood elevation 500 ft upstream.

Minimum standard design frequencies for temporary culverts, bridge-culverts and bridges are as follows:

DURATION OF TRAVERSING WORK	FREQUENCY
≤ 13 Months	2 years
13-40 Months	5 years
40-85 Months	10 years
> 85 Months	Use the Permanent Facilities Table in Section 4.3.1

In lieu of the above table the DSF may be determined using the equation:

$$DSF = 1 / [1 - (1 - R)^{1/N}]$$

where:

DSF = Design Storm Frequency,

N = Duration of Facility Usage in Years,

R = Risk of Occurrence of 100 year storm with a 75 year life span.

4.4 Backwater

The design of cross drain openings shall be consistent with backwater conditions as follows:

1. Backwater created by the structure shall be consistent with Flood Insurance Study requirements adopted by the local community in accordance with the **National Flood Insurance Program** and **FEMA** guidelines.
2. Any increase in backwater shall not significantly change land use values, unless flood rights are acquired. The acquisition of flood rights shall be based on a risk analysis to select the least total expected cost design.
3. The backwater for design frequency conditions shall be kept at or below the travel lanes.

4.5 Tailwater

For the sizing of cross drains and the determination of headwater and backwater elevations, the highest tailwater elevation which can be reasonably expected to occur coincident with the design storm event shall be used.

4.6 Clearances

The minimum vertical, horizontal, and regulatory clearance requirements for bridges shall conform to the requirements shown in the *FDOT Plans Preparation Manual* Volume 1 Chapter 2.

4.7 Hydrologic Analysis

4.7.1 Freshwater Flow

Hydrologic data for freshwater flow conditions used for the design of cross drains shall be based on one of the following methods as appropriate for the particular site:

1. A frequency analysis of observed (gage) data shall be used when available. If insufficient or no observed data is available, one of the procedures below shall be used as appropriate. However, the procedures below shall be calibrated to the extent practical with available observed data for the drainage basin or nearby similar drainage basins.
 1. Regional or local regression equation developed by the USGS.
 2. Rational Equation for drainage areas up to 600 acres.
2. For regulated or controlled canals, hydrologic data shall be requested from the controlling entity. Prior to use for design, this data shall be verified to the extent practical.

4.7.2 Tidal Flow

Hurricane rainfall runoff should be considered in conjunction with surge-driven tailwater when analyzing creeks and small rivers flowing into tidal water bodies. In such cases, since hurricane rainfall is largely independent of peak surge stage, the ACOE tropical storm rainfall runoff procedure from the *1986 Engineering and Design Storm Surge Analysis Manual (EM1110-2-1412)*, Chapter 4, should be used to estimate runoff from any design surge regardless of the surge return frequency being analyzed. The above procedure may be found at the website:

<http://www.dot.state.fl.us/rddesign/dr/FCHC.shtm>

Alternatively, a steady discharge equal to the peak flow from a 10-year storm may be used in lieu of the above *ACOE procedure*.

4.8 Hydraulic Analysis

4.8.1 Riverine Crossings

4.8.1.1 Bridges

FHWA's WSPRO and *FESWMS*, and *U.S. ACOE's UNET, HEC-RAS*, and *RMA-2*, are acceptable computer programs to analyze the hydraulic performance of bridges over riverine waterways.

4.8.1.2 Bridge-Culverts and Culverts

The hydraulic performance of bridge-culverts and culverts at riverine waterways shall be analyzed based on the techniques provided in *FHWA Hydraulic Design Series #5*.

4.8.2 Tidal Crossings

Coastal engineering analysis as typified by the U.S. Army Corps of Engineers and consistent with current coastal engineering practice should be used in the analysis of astronomical tides and hurricane storm surges. The computer programs acceptable for hydraulic analyses at tidal crossing are *HEC-RAS, UNET, RMA-2, ADCIRC*, and *FESWMS*.

The District Drainage Engineer should review tidal projects to determine if coastal hydraulics play a significant role in a roadway or bridge project's design. If coastal hydraulics might be significant, a qualified coastal engineer should review the complexity of the tidal conditions to determine the appropriate level of coastal engineering expertise needed in the design. Ideally, this review should be carried out in the preliminary engineering phase as specified in the *FDOT PD&E Manual*, Chapter 9. Conditions that typically require direct attention by a coastal engineer during the final design phase are as follows:

- Hydraulic analysis of interconnected inlet systems
- Analysis of inlet or channel instability, either vertically or horizontally
- Determination of design wave parameters
- Prediction of overwash and channel cutting
- Design of countermeasures for inlet instability, wave attack or channel cutting
- Prediction of sediment transport or design of countermeasures to control sediment transport

4.9 Specific Standards Relating to Bridges

4.9.1 Berms for Spill-Through Abutment Bridges

To facilitate construction, reduce scour potential, and provide for abutment stability, a minimum berm width of 10 ft shall be provided between the top edge of the main channel and the toe of spill through bridge abutments. See **Figure 4.1**. A greater berm width may be required. See **Section 4.9.3.2**. For manmade canals, the berm may be omitted at the direction of the maintaining agency.

4.9.2 Scour Estimates

4.9.2.1 Coordination

Scour estimates for bridges shall be developed using a multi-disciplinary approach involving the hydraulics engineer, the geotechnical engineer, coastal engineer (if needed per **Section 4.8.2**, above), and the structures engineer.

4.9.2.2 Scour Estimates

Scour elevation estimates for each bent shall be developed for the following:

Hydraulic Design Flood Frequency	Scour Design Flood Frequency	Scour Design Check Flood Frequency
Q ₁₀	Q ₂₅	Q ₅₀
Q ₂₅	Q ₅₀	Q ₁₀₀
Q ₅₀	Q ₁₀₀	Q ₅₀₀

- "Long term scour" for structures required to meet the extreme event vessel collision load.

Scour estimates shall be made using the procedures of **FHWA's Hydraulic Engineering Circulars (HEC) 18 and 20** except for the following:

- Tidal hydraulics analysis methodology shall follow **Section 4.8.2**.
- **Sheppard's Pier Scour Equation** shall be used rather than the **CSU Pier Scour Equation** when the total scour (general scour, contraction scour, and local scour) is greater than 5 ft.
- The **Florida Complex Pier Scour Procedure** shall be used in lieu of the complex pier scour procedure in **HEC 18**.
- The **Florida Rock / Clay Scour Procedure** shall be used to evaluate scour in scour resistant soils.

- **SED-2D** may be used to evaluate contraction scour in the absence of a clearly-defined upstream tidal floodplain. Guidance on the above Florida procedure may be found at the website:

<http://www.dot.state.fl.us/rddesign/dr/Bridgescour/Bridge-Scour-Policy-Guidance.shtm>

4.9.2.3 Scour Components

Scour estimates for items number 1 and 2 above, shall consist of the total scour resulting from the following:

1. Natural Channel aggradation and degradation anticipated during the life of the structure.
2. Channel Migration anticipated during the life of the structure.
3. Contraction scour.
4. Local scour, including pier scour and abutment scour. (Note: Abutment scour estimates are not required when the minimum abutment protection is provided.)

The "long-term scour" is the total 100-year scour for structures subject to clear water scour. For structures subject to live bed scour, the "long-term scour" is the normal, everyday scour at the piers combined with the degradation scour anticipated during the life of the structure. The following inset provides guidance for determining normal, everyday scour at the piers.

Normal, Everyday Scour at the Piers

For bridge replacements, parallel bridges, major widenings, etc., bridge inspection reports and the design survey should be the primary basis for determining normal everyday scour.

If the proposed piers are the same as the existing, the normal, everyday scour elevation should be that which is reflected in the inspection reports and the design survey. Slight differences in scour will likely exist between inspection reports and between the reports and the design survey. In these cases, an average scour elevation will be a reasonable estimate of normal, everyday scour. If there is a large difference, it may be due to an extreme storm event that occurred just before the inspection or survey was made. Investigate this and address these situations on a case by case basis.

For structures in which the proposed piers will be a different size or shape than the existing, it is recommended that the pier scour depth be adjusted. Using the inspection reports and the survey as discussed above, determine a normal, everyday scour depth at the pier. Adjust this depth using the following formula. The formula was derived by assuming only the pier width and shape change. Flow, velocity and depth are unchanged from existing to proposed.

$$y_{sp} = \frac{k_{1p}}{k_{1e}} \left[\frac{a_p}{a_e} \right]^{0.65} y_{se}$$

where:

- y_{sp} & y_{se} = scour depth for proposed pier and existing pier, respectively
- k_{1p} & k_{1e} = pier nose shape correction factor for proposed and existing pier, respectively
- a_p & a_e = pier width for proposed and existing pier, respectively

For new bridges/new alignments where there are no historical records available, the drainage engineer should look for hydraulically similar bridges in the area (preferably on the same water body) and estimate scour using the above guidelines. If there are no similar structures to use for comparison, contact the District Drainage Engineer for guidance on other methods for estimating normal everyday scour.

4.9.3 Scour Protection Considerations

4.9.3.1 General

Pier spacing and orientation, and abutment design shall be designed, balanced with other bridge design concerns, to minimize flow disruption and potential scour, subject to navigation requirements.

Abutment protection shall be designed as follows:

1. For protection against the effects of scour conditions consistent with design requirements stated above.
2. For the effects of wind generated waves and boat wake.

Revetment options, deemed to be inappropriate for the site, should be documented in the BHR. A Technical Specification, if needed, should be written based on the use of the most desirable revetment material, with the option to substitute the other allowable materials at no additional expense to the Department. This recommendation will help in eliminating revetment VECPs during construction.

Avoid corrodible metal cabling or baskets in coastal environments; even if coated, the coating may be marred and allow corrosion. Follow **ACOE Shore Protection Manual** for design of coastal revetment.

4.9.3.2 Minimum Abutment Protection

For spill-through abutments, where (1) design flow velocities do not exceed 7.7 fps, (2) Froude numbers are ≤ 0.80 , and (3) wave heights do not exceed 2.4 ft, minimum protection shall consist of one of the following placed on a 1(vertical) to 2 (horizontal) slopes:

- Rubble riprap (Bank and Shore), bedding stone, and filter fabric: Rubble riprap (Bank and Shore) is defined in the **Standard Specifications for Road and Bridge Construction**.
- Articulated concrete block (cabled and anchored).
- Grout-filled mattress (articulating with cabling throughout the mattress).

Site specific designs and technical specifications are required when using articulated concrete block or grout-filled mattress abutment protection. The **Structures Detailing Manual** provide typical details for standard revetment protection of abutments and extent of coverage. The horizontal limits of protection shall be determined using **HEC-23**. A minimum distance of 10 ft shall be provided if **HEC-23** calculations show less

than 10 ft.

Bulkhead abutments shall be protected by sheet piling with rubble toe protection below the bulkhead, and with revetment protection above the bulkhead when appropriate. When the design velocity in the contracted session is less than or equal to 7.2 fps, bank and shore rubble riprap shall be used. When the design velocity is above 7.2 fps, the size and density of the rubble shall be designed for site conditions. In all cases, the spatial extent of the rubble protection shall be designed for individual site conditions.

For wave heights greater than 3 ft, use S.G. = 2.65 rubble or other extra heavy revetment where large wave attack is expected, typically in coastal applications. In such cases, abutment protection should be extended beyond the bridge along embankments that may be vulnerable to wave attack during a hurricane. Wave attack above the peak design surge elevation and wave rebound scour at the toe of bulkheads must be considered. In such cases, a qualified coastal engineer should be consulted to determine the size and coverage of the revetment.

4.9.3.3 Pier Protection

Where revetment is deemed necessary to protect piers from scour, and upstream design flow velocities do not exceed 7.2 fps for rectangular piles or bascule piers, and 8.2 fps for round piling or drilled shafts, pier scour protection shall consist of one of the following:

- Rubble riprap (Bank and Shore), bedding stone, and filter fabric: Rubble riprap (Bank and Shore) is defined in the ***Standard Specifications for Road and Bridge Construction***.
- Articulated concrete block (cabled).
- Gabions (rock filled baskets)

Site specific designs and technical specifications are required when using articulated concrete block, gabions, or when using rubble and the design velocities exceed the above velocities.

4.9.4 Bridge Deck Drainage

4.9.4.1 Spread Standards

The spread on bridge decks and bridge approaches shall meet the spread standards in the ***Section 3.9***.

4.9.4.2 Scupper Drains

The standard scupper drain shall be 4" in diameter and spaced on 10 ft centers, unless spread calculations indicate closer spacing is required. Scuppers should not be directly discharging onto railroads, roadway travel lanes, or shared use paths, or sidewalks.

4.9.4.3 Bridge Sidewalk Drainage

Where bridge sidewalks are sloped away from the travel lanes, measures to capture runoff from the sidewalks are not required. If bridge sidewalk drainage is installed, scuppers must satisfy Americans with disabilities Act (ADA) requirements to have no more than ½" 'hole' in the walking surface.

4.9.5 Wave and Current Forces on Coastal Bridges

Where coastal bridges are not elevated at least 1 ft above the design wave crest elevation (DWC), a qualified coastal engineer with experience in wave mechanics shall provide 100-year design wave height, wave period and wave crest elevation along with accompanying horizontal and vertical surge and wave forces. Wave forces shall be computed according to **The Guide Specifications for Bridges Vulnerable to Coastal Storms**.

4.9.5.1 Required Level of Analysis

A qualified coastal engineer shall assist in the PD&E scoping effort, especially with structures exposed to severe wave attack. Determinations, including the appropriate level of analysis, will be made as outlined in the ***Structures Design Guidelines*** Section 2.5.

4.10 Specific Standards Relating to all Cross Drains Except Bridges

4.10.1 Culvert Materials

Culvert material selection shall be in accordance with ***Chapter 6*** of this ***Manual***.

4.10.2 Manning's Roughness Coefficients

Standard values for Manning's roughness coefficient are as follows:

Concrete Box Culverts	n = 0.012
Concrete Pipes	n = 0.012

Metal Pipes:

Pipe and Pipe Arch - Helical Fabrication	
Re-corrugated Ends - All Flow Conditions*	
12" – 24"	n = 0.020
30" – 54"	n = 0.022
60" and larger	n = 0.024

Pipe and Pipe Arch - Spiral Rib Fabrication	
Re-corrugated Ends - All Flow Conditions*	
All Sizes	n = 0.012

Structural Plate - Pipe and Pipe Arch	
Annular Fabrication - All Flow Conditions*	
All - 6 x 2	n = 0.033
All - 9 x 2-1/2	n = 0.034

Plastic Pipes:

Polyvinyl Chloride-PVC (external rib/smooth interior)	
All Sizes	n = 0.012

Polyethylene	
Single Wall	n = 0.024
Double Wall (Smooth)	n = 0.012

Polypropylene (All Sizes)	
Single Wall	n = 0.024
Double & Triple Wall (Smooth)	n = 0.012

* "Spiral" flow will not occur for most design situations. Therefore "spiral" flow design values have not been established. Values recommended by the Southeast Corrugated Steel Pipe Association are contained in the ***AISI Handbook of Steel Drainage & Highway Construction Products***.

4.10.3 End Treatment

The choice of end treatment and other hydraulic structures shall be selected/designed to satisfy hydraulic capacity, structural capacity, and safety (vehicular, pedestrian, cyclist) requirements.

Treatments are presented in the ***Standard Design Indexes of the Roadway and Traffic Design Standards***. The Standard Indexes provide guidance on end treatment selection.

4.10.3.1 Protective Treatment

Drainage designs shall be reviewed to determine if some form of protective treatment will be required to prevent entry to facilities that present a hazard to children and, to a lesser extent, all persons. General guidance on protective treatment is presented in ***Appendix D***. When grates are used, consideration shall be given to the effect of the grate and potential debris on the hydraulic capacity of the cross drain.

4.10.3.2 Roadside Safety

The type and location of end treatment shall comply with roadside safety and clear zone requirements. See the ***Plans Preparation Manual*** for clear zone requirements and the ***Design Standard Indexes*** for end treatment safety guidance.

4.10.4 Construction and Maintenance Considerations

The design of culverts shall be consistent with the standard construction and maintenance practices of the Department. Standard details for inlets, manholes, junction boxes, end treatments, and other miscellaneous drainage details are provided in the ***Design Standard index drawings***. Specifications are provided in the ***Standard Specifications for Road and Bridge Construction***. In the event standard index drawings are not suitable for a specific project need, a detailed design shall be developed and included in the plans; and, as appropriate, special provisions shall be provided for inclusion with the project specifications. Proper design shall also consider maintenance concerns of adequate physical access for cleaning and repair.

4.10.4.1 Minimum Culvert Sizes

Minimum culvert sizes are as follows:

<u>Culvert Type</u>	<u>Minimum Size</u>
Cross Drain	18"
Median Drain	15" *, **
Side Drain	15" *
Box Culvert (Precast)	3' x 3'
Box Culvert (Cast in Place)	4' x 4'
Drains from inlets on high fills (e.g., gutter drains)	15" **

* Some locations require 18" minimum. The designer shall consider future improvements, hydraulic requirements, debris control, and maintenance access. Verify project specific requirements with the District Drainage Engineer.

** When debris control is not provided by grates, use 18" minimum.

For culverts requiring more than a double line of pipe, other alternatives shall be investigated.

Extensions of existing culverts shall be made with the existing pipe material. In the event that the existing pipe material is no longer produced, use the most similar material available, i.e. extend fiber reinforced concrete pipe with concrete pipe (RCP or NRCP).

4.11 Documentation

4.11.1 Culverts (all culverts less than a 20' bridge culvert)

4.11.1.1 Extensions of Culverts with No Known Historical Problems

For extensions of culverts that have no signs of undesirable scour at inlet and outlet ends; no excessive sedimentation; and no history of problems, the documentation shall include as a minimum the following:

1. Evidence of contact with Maintenance Office
2. Evidence of Field Review
3. Discharge Computations

4. Hydraulic Computations (HDS#5), including any design assumptions

4.11.1.2 New or Replacement Culverts and Extensions of Culverts with Known Historical Problems

At a minimum the documentation shall include:

1. Evidence of contact with Maintenance Office
2. Evidence of field review
3. Drainage Map
4. Hydrologic Computations
5. Hydraulic computations (**HDS #5**), including any design assumptions
6. Assessment of the problem (for culverts with known problems)
7. Alternative analysis
8. Optional Materials Evaluation

4.11.2 Bridges

Bridge hydraulic design computations and analyses shall be documented in a permanent record file. The permanent record file shall address all design standards provided herein. Documentation shall be provided in detail commensurate with the complexity of the project. Documentation shall be sufficient enough so that an independent engineer with expertise in bridge hydraulics, but not involved with the design, can fully interpret, follow and understand the logic, methods, computations, analysis and considerations used to develop the final design.

4.11.2.1 Bridges on Controlled Canals

Bridges on controlled canals not affected by hurricane surge may utilize the short format BHR located in Chapter 5 of the ***Bridge Hydraulics Handbook***.

4.11.2.2 Bridge or Bridge Culvert Widening

At a minimum the documentation shall include:

1. Completed Bridge Hydraulics Recommendations Sheet (BHRS), including complete design recommendations is required for bridges, not bridge culverts. The format for the BHRS is provided in the ***Plans Preparation Manual***.
2. Evidence of Field Review.
3. Hydrologic analysis including sources of data and methodology.
4. Hydraulic Computations, including any design assumptions. A disk with the input file(s) for the final computer run should be provided.
5. Scour Analysis:

1. Scour Computations
2. Scour Protection Needs
6. Applicable regulatory agency documents that affect the final design. This may include documents from the Corps of Engineers, Coast Guard, water management district, DEP, etc.
7. Deck Drainage analysis and computations.

4.11.2.3 Bridge Culverts

At a minimum the documentation shall include:

1. Evidence of Field Review.
2. Hydrologic analysis including sources of data and methodology.
3. Hydraulic Computations, including any design assumptions. A disk with the input file(s) for the final computer run should be provided.
4. Scour analysis addressing the need for inlet and/or outlet protection.
5. A summary of the alternatives considered, including cost estimates and reasons for selecting the recommended structure, and a clear explanation as to why it is the most economical structure for the site in question.
6. Applicable regulatory agency documents that affect the final design. This may include documents from the Corps of Engineers, Coast Guard, water management district, DEP, etc.
7. For Interstate system bridges over floodplains where a Regulatory Floodway has not been established, the documentation must include the evaluation required in Section 4.4 of this Chapter.

4.11.2.4 Category 1 and 2 Bridges

At a minimum the documentation shall include:

1. Completed Bridge Hydraulics Recommendations Sheet (BHRS). The format for the BHRS is provided in the *Plans Preparation Manual*.
2. Bridge Hydraulics Report including:
 1. A summary of all design recommendations, including:
 1. Bridge Length, including locations (stations) of abutments.
 2. Channel Excavation requirements
 3. Minimum Vertical Clearance
 4. Minimum Horizontal Clearance
 5. Abutment type and orientation.
 6. Pier Orientation
 7. Scour Depths
 1. Scour Design Event

2. Scour Check Event
8. Scour protection requirements for abutments, piers, and channel. For spill-through abutments, recommendations shall include:
 1. Abutment Slope
 2. Type of Protection (rubble riprap is standard)
 3. Horizontal and Vertical Extent of Protection
9. Deck Drainage requirements
10. Wave and surge parameters and force determination (or calculation) and analysis (for coastal bridges not elevated 1 ft above the design wave crest elevation.)
2. Evidence of Field Review
3. Hydrologic analysis including sources of data and methodology.
4. Alternative analysis or evaluation of structure sizes (length and vertical height/clearance). This evaluation shall be done consistent with Department policy for bridge hydraulic design and shall include consideration of:
 1. Cost
 2. Design standards
 3. Structure hydraulic performance, including backwater, velocity, and scour.
 4. Impacts of the structure on adjacent property
 5. Environmental impacts
5. The alternative analysis shall include the reasons for selecting the recommended structure, and a clear explanation as to why it is the most economical structure for the site in question. As a minimum, the following structure sizes shall be evaluated:
 1. The minimum structure size required to meet hydraulic standards for vertical and horizontal clearance, scour, and backwater.
 2. Existing structure size if applicable.
 3. The recommended structure size if different from (1) or (2).
6. Deck Drainage analysis
7. Supporting Hydraulic Computations including
 1. Computer analysis, if appropriate, including a plan view of cross section locations and a disk with final input file(s).
 2. Scour Computations
 3. Deck Drainage computations
 4. Design Assumptions
 5. Wave and surge parameters and force determinations and analysis (for coastal bridges not elevated 1 ft above the design wave crest elevation.)

8. Applicable regulatory agency documents that affect the final design. This may include documents from the Corps of Engineers, Coast Guard, WMD, DEP, etc.

4.11.3 Document Processing

Processing of the BHR/BHRS and other supporting design documents shall be in accordance with the ***FDOT Plans Preparation Manual***.

Figure 4.1 - Bridge Berms for Spill-through abutments

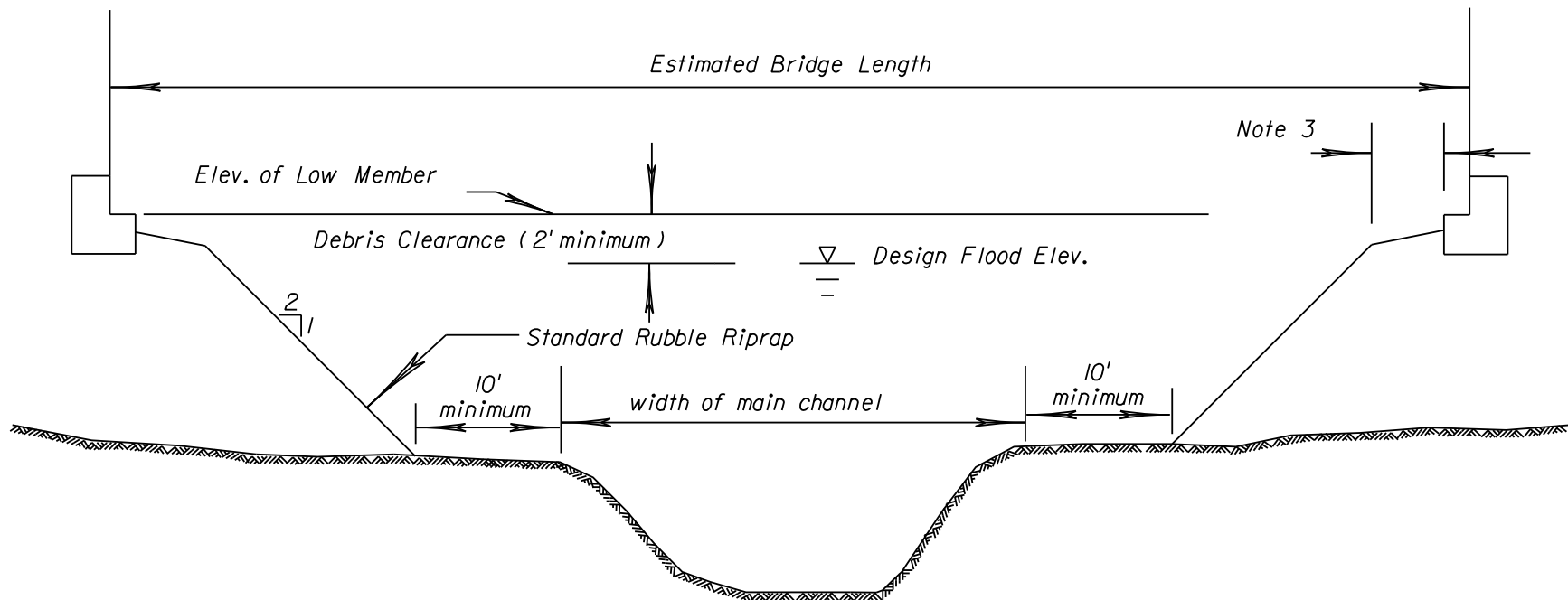

NOTES:

1. 10' berm widths only required when main channel can be defined.
2. See Section 4.6.1 for minimum vertical navigational clearances.
3. See Structures Detailing Manual for minimum berm at top of abutment.

Chapter 5

Stormwater Management

5.1 Introduction

This chapter presents standards for the design of stormwater management systems for Department projects. Guidance for drainage connection permits are covered in the *FDOT Drainage Connection Permit Handbook*.

5.2 Regulatory Requirements

5.2.1 Chapter 14-86, Florida Administrative Code

The design of stormwater management systems for Department projects shall comply with the water quality, rate, and quantity requirements of **Section 334.044(15), F.S., Chapter 14-86, F.A.C.**, Rules of the Department of Transportation in closed basins or areas subject to historical flooding.

5.2.2 Section 373.4596, Florida Statutes

Section 373.4596, Florida Statutes requires the Department of Transportation to fully comply with state, water management district and, when delegated by the State, local government stormwater management programs.

5.2.3 Chapter 62-25, Florida Administrative Code

Chapter 62-25, F.A.C., rules of the Florida Department of Environmental Protection specifies minimum water quality treatment standards for new development.

5.2.4 Chapter 62-40, Florida Administrative Code

Chapter 62-40, F.A.C., rules of the Florida Department of Environmental Protection outlines basic goals and requirements for surface water protection and management to be implemented and enforced by the Florida Department of Environmental Protection and Water Management Districts.

5.2.5 National Pollutant Discharge Elimination System

The *National Pollutant Discharge Elimination System (NPDES) permit program* is administered by the U. S. Environmental Protection Agency. This program requires permits for stormwater discharges into waters of the United States from industrial activities, and from large and medium municipal separate stormwater systems.

5.3 Design Standards

5.3.1 Design of Systems

5.3.1.1 General

Stormwater management facilities should be designed to provide the necessary quantity, rate, and quality control based on the presumption that for the existing discharge all necessary quantity, rate, and quality control of stormwater from upper property has occurred prior to reaching the right-of-way. Consistent with this presumption, the most economically feasible of the following shall be provided:

1. Separation of offsite discharges from the Departments stormwater management facilities;
2. Consideration shall be given to joint use, and/or regional treatment facilities in cooperation with local, regional and/or private organizations.
3. Initial pond routing should start at control elevation except at locations of anticipated frequent orifice clogging. The weir elevation may be used as the starting elevation provided there is no significant additional cost to the project.

5.3.1.2 Watersheds with Positive Outlets

Projects located in watersheds with positive outlets shall comply with the discharge requirements of Rule 14-86 FAC when discharging to areas subject to historical flooding. These systems must also address water quality requirements.

5.3.1.3 Watersheds without Positive Outlets

For projects that are located within a watershed that contributes to a depressed low area, or a lake that does not have a positive outlet such as a river or stream to provide relief (i.e., closed basin or isolated depression), a detention/retention system is required.

The detention/retention system shall be of sufficient size to ensure that the post

developed discharge volumes do not exceed the pre-developed discharge volumes for the critical duration as specified in **Rule 14-86 FAC**. The retention volume should recover at a rate such that one-half of the volume is available in 7 days with the total volume available in 30 days, with a sufficient amount recovered within the time necessary to satisfy applicable water treatment requirements.

The detention requirements are the same as those described in **Section 5.3.1.2**.

5.3.1.4 Exceptions

5.3.1.4.1 Tidal Areas

Water quantity and rate control criteria are not applicable for projects which discharge directly into tidal areas. This is subject to permission of the appropriate permitting authority.

5.3.1.4.2 Downstream Improvement

Water quantity and rate control criteria are not applicable where it can be demonstrated that downstream conveyance and storage systems have adequate capacity, or will be improved to have adequate capacity for the increased quantity and rate of runoff created by the project. This is subject to permission of the downstream property owner(s), and the appropriate permitting authority.

5.3.1.4.3 Replacement Treatment

For projects where available right-of-way is insufficient and cannot be feasibly obtained for proper treatment (quantity, rate, quality), treatment of existing untreated offsite areas which discharge to the same receiving water body may be substituted in lieu of treating the project. This is subject to permission of the property owner downstream of the untreated project area, and the appropriate permitting authority.

5.3.1.4.4 Permission from the Downstream Property Owner

Water quantity and rate control criteria can be waived when the downstream property owner(s) agrees to accept the increased quantity and rate of runoff created by the project. This approach is subject to appropriate exemption by the permitting authority.

5.3.2 Hydrologic Methods

The hydrologic method used shall be one of the following:

1. Modified Rational for basins having a time of concentration of 15 minutes or less.
2. SCS Unit Hydrograph Method

5.3.3 Protective Treatment

Stormwater management facilities shall be designed with due consideration of the need for protective treatment to prevent hazards to persons. General guidance on protective treatment is provided in **Appendix D**. Flat slopes shall be used when practical. Retention areas shall be fenced in accordance with **Section 5.3.4**, and to prevent entry into areas of unexpected deep standing water or high velocity flow. Grates shall be considered to prevent persons from being swept into long or submerged drainage systems. Guards shall be considered to prevent entry into long sewer systems under no-storm conditions, to prevent persons from being trapped.

5.3.4 Construction and Maintenance Considerations

5.3.4.1 General

The design of stormwater management systems shall be consistent with the standard construction and maintenance practices of the Department. Standard details for inlets, manholes and junction boxes, end treatments, and other miscellaneous drainage details are provided in the standard index drawings. Specifications are provided in the **Standard Specifications for Road and Bridge Construction**. In the event standard index drawings are not suitable for a specific project need, a detailed design shall be developed and included in the plans; and, as appropriate, special provisions shall be provided for inclusion with the project specifications. Proper design shall also consider maintenance concerns of adequate physical access for cleaning and repair.

5.3.4.2 Detention and Retention Ponds

Standard design features for detention and retention ponds are shown in **Figure 5.1** and are as follows:

1. Maintenance Berm:
Ponds shall be designed to provide a minimum 20 ft of horizontal clearance

between the top edge of the normal pool elevation and the right-of-way line. At least 15 ft adjacent to the pond shall be at a slope of 1:8 or flatter. The berm area shall be sodded. In areas of limited R/W, discuss maintenance needs with Department before acquiring additional R/W to construct maintenance access around full perimeter.

2. Corners:

Corners of ponds shall be rounded to provide an acceptable turning radius for maintenance equipment.

3. Freeboard:

As a safety factor for hydrologic inaccuracies, control structure clogging, and downstream stage uncertainties, at least 1 ft of freeboard is required above the maximum design stage of the pond. The freeboard is the vertical distance between the maximum design stage elevation of the pond and the front face of the berm as illustrated in **Figure 5-1**.

For linear treatment swales, the freeboard may be reduced to 0.5 ft when 1ft is not attainable.

4. Fencing:

Ponds having side slopes steeper than 1:4 shall be provided a protective barrier (e.g., wall, fence, etc.) to prevent unauthorized entry. Refer to **Appendix D** (Part 2 - Protective treatment) for other considerations. **Appendix D** is a guideline and not a standard. Gates for maintenance equipment access shall be placed at appropriate locations.

5. Access Easements:

When pond areas are not accessible directly from the road right-of-way, an access easement shall be provided.

5.3.4.3 Exfiltration Trenches

Exfiltration systems (French drains) shall be designed using **Design Standard Index Drawing 285**. Designs shall include provisions for overflow resulting from floods exceeding the design storm condition.

5.4 Documentation

The documentation for stormwater management facilities shall be sufficient to justify the facility, and describe the design and operation. At a minimum the documentation shall include:

-
1. Pond Siting Evaluation (required only if additional right of way is obtained for the pond) consisting of:
 1. Identification of alternate sites.
 2. For each alternate include preliminary information about:
 1. Right of way costs.
 2. Water quality and quantity volumes.
 3. Soil and groundwater conditions.
 4. Potential hazardous waste contaminations.
 5. Potential impacts to endangered species.
 6. Potential impacts to cultural resources.
 7. Potential impacts to utilities.
 2. Drainage Map.
 3. Evidence of field review.
 4. Description of applicable regulatory requirements.
 5. Description of pre-developed runoff characteristics such as basin boundaries, outfall locations, peak runoff rates, and methods of conveyance.
 6. Description of post-developed runoff characteristics such as those listed in item five.
 7. Schematic of interconnected ponds (if applicable).
 8. Description of the operation of the facility. This will be used by design reviewers, but is intended for maintenance personnel who may have to certify that the facility is operating as designed.
 9. Soils and groundwater information.
 10. Stage versus storage values.
 11. Electronic file of routing calculations.
 12. Any special maintenance requirements

2/6/08

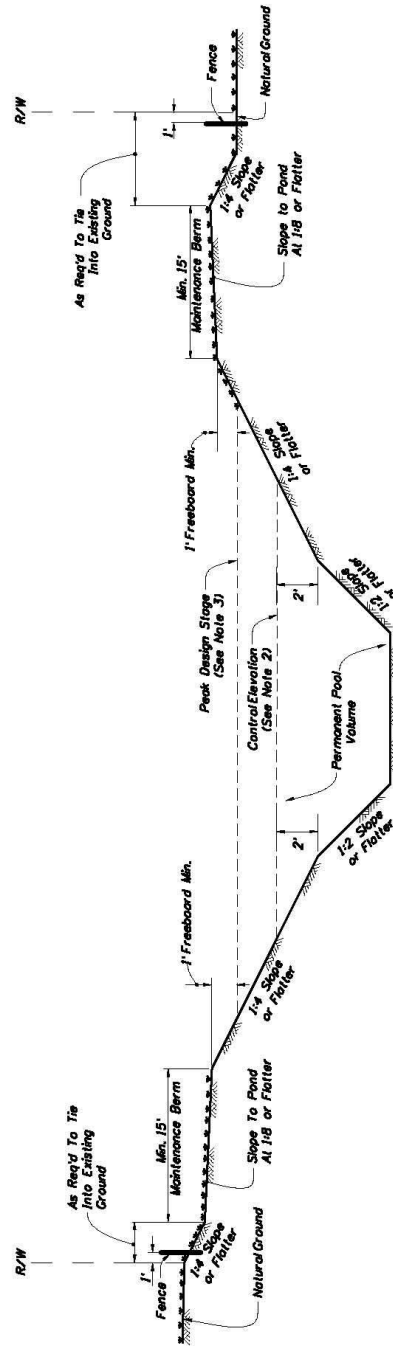

NOTES:

1. Fencing Only Required If Shown In The Plans.
2. Permanent Pool Shall Be At Or Below This Elevation.
3. Peak Design Stage Shall Be At Or Below This Elevation.

Figure 5-1
 Minimum Clearance
 Retention-Detention
 Ponds

M:\Private\Projects\131\131\131 New Pond Berm.dgn

Chapter 6

Optional Culvert Materials

6.1 Introduction

Optional culvert materials shall be considered for all culvert applications including, but not limited to, storm drains, cross drains, side drains, gutter drains, and French drains. All culvert materials shown in **Table 6-1** for the application being designed shall be evaluated. The evaluation shall consider functionally equivalent performance in three areas: durability, structural capacity, hydraulic capacity.

6.2 Durability

Culverts shall be designed for a design service life (DSL) appropriate for the culvert function and highway type. Department requirements for DSL are provided in **Table 6-1**. The projected service life of pipe material options called for in the plans shall provide, as a minimum, the Design Service Life. Pipe material standards shall not be reduced when projected service life exceeds design service life.

In estimating the projected service life of a material, consideration shall be given to actual performance of the material in nearby similar environmental conditions, its theoretical corrosion rate, the potential for abrasion, and other appropriate site factors. Theoretical corrosion rates shall be based on the environmental conditions of both the soil and water. As a minimum the following corrosion indicators shall be considered:

1. pH
2. Resistivity
3. Sulfates
4. Chlorides

Tests for the above characteristics shall be based on FDOT approved test procedures. To avoid unnecessary site specific testing, generalized soil maps may be used to delete unsuitable materials from consideration. The potential for future land use changes which may change soil and water corrosion indicators shall also be considered to the extent practical.

6.2.1 Culvert Service Life Estimation

The computer program, Tables and Figures (found in **Appendix B** of the **Optional Pipe Handbook**), and/or criteria stated below should be used in evaluating the estimated service life for the following culvert materials:

Culvert Service Life Estimator Program:	Available on the internet and from Maps & Publications (See Chap. 1 for address)
Galvanized Steel:	Figure 6-1 and Table 6.2
Aluminized Steel:	Figure 6-2 and Table 6.3
Aluminum:	Figure 6-3 and Table 6.4
Reinforced Concrete:	Figure 6-4 and Table 6.5
Non-reinforced Concrete:	100 Years (pH \geq 4.0)
HDPE-II:	100 Years
HDPE-I:	50 Years
Polypropylene (PPP)	50 Years
F949 PVC	100 Years
Other Polyvinyl Chloride:	50 Years

Note: Estimated Service Life for metal pipe may be increased by 10 years, if it is coated with a bituminous coating.

6.3 Structural Evaluation

Design Standard Index Drawing 205 provides minimum and maximum cover requirements. The minimum thickness established to meet Durability requirements shall be evaluated to assure structural adequacy and increased if necessary. Materials and sizes not listed in **Index 205** shall be evaluated using **AASHTO design guidelines** and industry recommendations, and modified as necessary to be consistent with **Index 205** and any applicable specifications and installation procedures.

6.4 Hydraulic Evaluations

The hydraulic evaluation shall establish the hydraulic size in accordance with the design standards provided in the **Drainage Manual** for the particular culvert application. For storm drains and cross drains, the design shall use the Manning's roughness coefficient associated with concrete pipe, spiral rib pipe, polyethylene pipe and polyvinyl chloride pipe.

For side drains, the hydraulic design shall use a one-size design. If a material type is considered to be inappropriate, it will need to be eliminated as an option in the plans.

In addition, the hydraulic evaluation shall verify that the standard joint performance as required by the **Standard Specifications**, Section 430-4.1 will be sufficient. For situations where the minimum joint performance as required by the **Standard Specifications** is not sufficient, special provisions to specify the proper joint shall be provided in the plans. For example, a pump station with a small diameter pressurized storm drain should use a High Pressure joint. (Note: Joints are tested and rated by the State Materials Office.)

6.5 Culvert Material Types

The types of culvert materials to be considered for the various culvert applications are as follows. Other materials may be considered, but are not required to be.

Application	Materials to be Considered
Cross Drain French Drain Side Drain Storm Drain	Aluminized Steel Aluminum Concrete (all types) Corrugated Polyethylene (60" maximum) Polyvinyl Chloride (42" maximum) Polypropylene (60" maximum) Galvanized Steel
Gutter Drain	Corrugated Aluminized Steel ($n > 0.020$) Corrugated Aluminum ($n > 0.020$) Corrugated Steel ($n > 0.020$)
Vertical Drain	Ductile Iron (In saline environments, consider fiberglass reinforced pipe and F949 PVC)

The **Plans Preparation Manual** illustrates a method of presenting the acceptable pipe materials in the plans.

6.6 Jack and Bore

When drainage structures are installed using jack and bore, the casing shall be used as the carrier pipe except under railroads or in higher pressure designs. Information on calculating pipe thickness for corrosion resistance can be found in the **Culvert Service Life Estimator** (2010 version or later) and in the **Optional Pipe Handbook**.

6.7 Documentation

The documentation shall be sufficient to justify eliminating material types from being acceptable and shall include at a minimum the following:

1. Design Service Life required.
2. Soil and water corrosion indicators used in estimating service life.
3. Estimates of service life at cross drains and at various locations of storm drain systems.
4. Structural Evaluation (comparison of maximum and minimum cover heights to actual cover height).

TABLE 6-1 CULVERT MATERIAL APPLICATIONS AND DESIGN SERVICE LIFE

Application	Storm Drain		Cross Drain		Side Drain ⁴	Gutter Drain	Vertical Drain ¹⁰	French Drain			
	Minor	Major	Minor	Major	All	All	All	Replacement will Impact the Roadway ⁵		Other	
Design Service Life →	50	100	50	100	25	25 ⁶	100	Minor	Major	All	
Culvert Material	An * indicates suitable for further evaluation.										
P I P E	Corrugated Aluminum Pipe CAP	*	*	*	*	*	*		*	*	*
	Corrugated Steel Pipe CSP	*	*	*	*	*	*		*	*	*
	Corrugated Aluminized Steel Pipe CASP	*	*	*	*	*	*		*	*	*
	Spiral Rib Aluminum Pipe SRAP	*	*	*	*	*	*		*	*	*
	Spiral Rib Steel Pipe SRSP	*	*	*	*	*	*		*	*	*
	Spiral Rib Aluminized Steel Pipe SRASP	*	*	*	*	*	*		*	*	*
	Steel Reinforced Concrete Pipe SRCP	*	*	*	*	*	*		*	*	*
	Non-reinforced Concrete Pipe NRCP	*	*	*	*	*	*		*	*	*
	Fiber Reinforced Concrete Pipe FRCP	*	*	*	*	*	*		*	*	*
	Polyethylene Pipe – Class I HDPE-I	*		*		*			*		*
	Polyethylene Pipe – Class II ⁸ HDPE-II	*	*	*	*	*			*	*	*
	Polypropylene Pipe PPP	*		*		*			*		*
	Polyvinyl-Chloride Pipe ⁷ PVC	*	F949	*	F949	*		F949	*	F949	*
Fiberglass Pipe							*				
S T R U C T U R A L P L A T E	Structural Plate Aluminum Pipe SPAP	*	*	*	*	*					
	Structural Plate Alum. Pipe-Arc SPAPA	*	*	*	*	*					
	Structural Plate Steel Pipe SPSP	*	*	*	*	*					
	Structural Plate Steel Pipe-Arch SPSPA	*	*	*	*	*					
B O X	Aluminum Box Culvert	*	*	*	*	*					
	Concrete Box Culvert CBC	*	*	*	*	*					
	Steel Box Culvert	*	*	*	*	*					

Table notes are on the following page

Notes for Table 6-1

1. A minor facility is permanent construction such as minor collectors, local streets and highways, and driveways, provided culvert cover is less than 10 ft. Additionally, this category may be called for at the discretion of the District Drainage Engineer where pipe replacement is expected within 50 years or where future replacement of the pipe is not expected to impact traffic or require extraordinary measures such as sheet piling.
2. A major facility is any permanent construction of urban and suburban typical sections and limited access facilities. Urban facilities include any typical section with a fixed roadside traffic barrier such as curb or barrier wall. Additionally, rural typical sections with greater than 1600 AADT are also included in this category.
3. Temporary construction normally requires a much shorter design service life than permanent does. However, temporary measures that will be incorporated as permanent facilities should be treated as permanent construction with regard to design service life determination.
4. Although culverts under intersecting streets (crossroads) function as side drains for the project under consideration, these culverts are cross drains and shall be designed using appropriate cross drain criteria.
5. Replacing this pipe would require removal and replacement of the project's pavement or curb.
6. Gutter Drains under retaining or through walls should use a 100 year DSL.
7. F949 PVC service life is 100 years. Other PVC pipe has a 50 year service life. PVC pipe should not be used in direct sunlight unless it meets the requirements of **Specification 948-1.1**.
8. Class II HDPE pipe may not be used in the Florida Keys.
9. Any pipes under or adjacent to permanent structures such as retaining walls, MSE walls, buildings, etc. shall use a 100 year DSL.
10. Resilient connections required for all vertical pipes.

Appendix A: 23 CFR 650 A

<http://www.fhwa.dot.gov/legsregs/directives/fapg/cfr0650a.htm>

Appendix B: IDF Curves, Precipitation Data, Rainfall Distributions

<http://www.dot.state.fl.us/rddesign/dr/files/IDFCurves.pdf>

Appendix C

Drainage Law

APPENDIX C

DRAINAGE LAW

C.1 OVERVIEW

Current drainage law has evolved from case law in the courts, administrative hearing rulings, and the requirements which have been placed on the Department by other regulatory agencies. The discussion presented in this chapter of the Department's legal rights and responsibilities to the public as they relate to highway drainage is not intended as a substitute for legal counsel, but rather to familiarize engineers with basic drainage law, terminology, rules, and applications as they relate to state road design and maintenance.

C.2 TERMINOLOGY

Applicable Standards or Applicable water Quality Standards or Minimum Design and Performance Standards: Those discharge standards of the appropriate regulatory entity which apply to the facility under consideration.

Approved Stormwater Management Plan or Master Drainage Plan: A regional plan adopted or approved by a city, county, Water Management District, or other agency with specific drainage or stormwater management authority; provided that (a) such plan is actively being implemented; (b) any required construction is substantially complete; (c) downstream mitigative measures have been provided for in the plan; and (d) that the use of any Department facilities either existing or planned, which are part of such plan have been agreed to by the Department.

Artesian Waters: Percolating waters confined below impermeable formations with sufficient pressure to spring or well up to the surface.

Backwater: An unnaturally high stage in a stream caused by obstruction or confinement of flow, as by a dam, a bridge, or a levee. Its measure is the excess of unnatural over natural stage, not the difference in stage upstream and downstream from its cause.

Concentration: The unnatural collection or convergence of waters, discharging in a narrower width and at a greater depth or velocity.

Critical Duration: The length of time of a specific storm frequency which creates the largest volume or highest rate of net stormwater runoff (post-improvement runoff less pre-improvement runoff) for typical durations up through and including the 10-day duration for closed basins and up through the 3-day duration for basins with positive outlets. The critical duration for a given storm frequency is determined by calculating the peak rate and volume of stormwater runoff for various storm durations and then

comparing the pre-improvement and post-improvement conditions for each of the storm durations. The duration resulting in the highest peak rate or largest net total stormwater volume is the “critical duration” storm (volume is not applicable for basins with positive outlets).

Diversion: (1) The taking of water from a stream for a beneficial purpose (irrigation, water supply, power, etc.) even though a portion may return to the same stream. (2) The deflection of surface waters or stream waters so that they discharge into a watercourse to which they are not naturally tributary. Deflection of flood water is not diversion.

Drainage Connection: Any structure, pipe, culvert, device, paved or unpaved area, swale, ditch, canal, or any other appurtenance or feature, whether naturally occurring or created, which is used or functions as a link to convey stormwater.

Easement: The right to use the land of others. It may derive from the common law or be acquired, usually by purchase or condemnation, but occasionally by prescription or inverse condemnation. The right is not exclusive, but subject to rights of others in the same land, the lesser right being servient to a prior dominant right. Easements for drainage may give rights to impound, divert, discharge, concentrate, extend pipelines, deposit silt, erode, scour, or to perform any other necessary activity of a highway development.

Use of land of others without right usually leads to right in the future. If use is adverse and notorious for a statutory period, an easement is acquired by prescription with compensation, but, at any earlier time, the owner of the other land may sue for compensation by inverse condemnation.

Erosion and Accretion: Loss and gain of land, respectively, by the gradual action of a stream in shifting its channel by cutting one bank while it builds on the opposite bank. Property is lost by erosion and gained by accretion, but not by avulsion, when the shift from one channel to another is sudden. Property is gained by reliction when the water in an ocean, lake, river, or stream recedes.

Engineer: A Professional Engineer registered in Florida pursuant to the provisions of Chapter 471, **Florida Statutes**, who as appropriate is competent in the fields of hydraulics, hydrology, stormwater management or stormwater pollution control.

Erosion and Scour: The cutting or wearing away by the force of water of the banks and bed of a channel in horizontal and vertical directions, respectively.

Facility: Anything built, installed, or maintained by the Department within the Department’s right of way.

Flood Waters: Former stream waters which have escaped from a watercourse (and it's overflow channel) and flow or stand over adjoining lands. Flood waters remain as such until they disappear by infiltration, evaporation, or return to a natural watercourse; they do not become surface waters by mingling with such waters or stream waters by eroding a temporary channel.

Groundwater: Water situated below the surface of the land, irrespective of its source and transient status. Subterranean streams are flows of groundwater parallel to and adjoining stream waters, and are usually determined to be integral parts of the visible streams.

Impervious Areas: Surfaces which do not allow, or minimally allow, the penetration of water. Examples of impervious areas are building roofs, all concrete and asphalt pavements, compacted traffic-bearing areas such as limerock roadways, lakes, wet ponds, pond liners, and other standing water areas, including some retention/detention areas.

Improvement: Any manmade change to property from previously existing conditions.

Marshes: Lands saturated by waters flowing over the surface in excess of infiltration capacity, such as sloughs or rivers and tidal channels.

Navigable Waters: Those stream waters lawfully declared or actually used as such.

Navigable Waters of the United States: Those bodies of water determined by the Chief of the U. S. Army Corps of Engineers to be so used in interstate or international commerce. Other streams have been ruled navigable by courts under the common law that navigability in fact is navigability in law.

Owner: Any owner of land, usually specified in relation to another owner. Of two owners affected by the flow of water, the one upland is the upper owner and the other the lower owner. The highway has an owner with the same rights in common law as private owners.

Peak Discharge: The maximum flow of water passing the point of interest during or after a rainfall event.

Perched Waters: Percolating waters detained or retained above an impermeable formation, standing above and detached from the main body of groundwater.

Percolating Waters: Those which have infiltrated the surface of the land and moved slowly downward and outward through devious channels (aquifers) unrelated to stream waters, until they either reach an underground lake or regain and spring from the land surface at a lower point.

Positive Outlet: A point of stormwater runoff into surface waters which under normal conditions would drain by gravity through surface waters ultimately to the Gulf of Mexico, or the Atlantic Ocean, or into sinks, closed lakes, or recharge wells provided the receiving waterbody has been identified by the appropriate Water Management District as functioning as if it recovered from runoff by means other than transpiration, evaporation, percolation, or infiltration.

Pre-improvement: The condition of property before an improvement is made or, in regard to **Rule 14-86, F.A.C.**, The condition of property (a) Before November 12, 1986; or (b) On or after November 12, 1986, with connections which have been permitted under **Rule 14-86, F.A.C.** or permitted by another governmental entity based on stormwater management requirements equal to or more stringent than those in **Rule 14-86, F.A.C.**

Stormwater: The flow of water that results from and occurs immediately following a rainfall event.

Stream Waters: Former surface waters that have entered and now flow in a well-defined natural watercourse together with other waters reaching the stream by direct precipitation or from springs in the bed or banks of a watercourse. They continue as stream waters as long as they flow in the watercourse, including in overflow and multiple channels as well as the ordinary or low water channel.

Surface Water: Water upon the surface of the earth, whether contained in natural or artificial boundaries or diffused. Water from natural springs shall be classified as surface water when it exits onto the earth's surface.

Swamps: Lands saturated by groundwater standing at or near the surface.

Volume: The total amount of water coming to a point of interest. It may be from surface water, watercourses, groundwater, or direct precipitation.

Watercourse: A definite channel with bed and banks within which water flows, either continuously or in season. A watercourse is continuous in the direction of flow and may extend laterally beyond the definite banks to include overflow channels contiguous to the ordinary channel. The term does not include artificial channels such as canals and drains, except as natural channels are lawfully trained or restrained by the works of man. It also does not include depressions or swales through which surface or errant waters pass.

Watershed: The region draining or contributing water to a common outlet, such as a stream, lake, or other receiving area.

C.3 SURFACE WATER LAW

C.3.1 UPLAND OWNER

Generally, an upland owner has an easement over the land of the lower land owner for surface waters that flow over the lower land. In exchange for this privilege, the upland owner has the duty not to divert surface waters, change the velocity of flow, add to the pollution, or increase the amount of waters from other directions to the extent that damage occurs on the lower lying property of the other land owner. Ideally, the surface-water flow should imitate the conditions in existence when the lands were in a natural state. Realistically, changes made in the development of real property are reviewed by the courts on a case-by-case basis to determine whether the changes which occur are substantial and whether the development has been reasonable. A major factor, if the courts find that a nuisance has been created by the upland owner on the lower land, is whether or not the lower land owner came to the nuisance.

C.3.2 LOWER LAND OWNER

Generally, the lower land owner has the duty to the upland owner not to prevent or obstruct the flow of surface waters onto his land from that of the upland owner. The lower land owner cannot exclude these surface waters, nor can he cause the water to flow back to his upland neighbor. One exception to this rule is when such a backflow is a natural condition which could be anticipated from the natural configurations of the land. An example of this exception would be a land-locked storage basin that overflows in an intense storm of long duration. Even if it is foreseeable, the overflow onto the neighboring land when caused by natural conditions is not a trespass by the lower land owner. However, if the lower land owner diverted additional waters into the land-locked basin, and took the chance that such a natural event could occur, the lower land owner may be responsible for the surface-water overflow onto the neighboring property.

Another exception to the responsibilities owed to the lower land owner can be found in the low lying areas in South Florida where indiscriminate rim ditching was allowed. If the lower land owner came to this condition, he cannot assert a trespass or nuisance claim.

If the Department is involved in any way, on any side of the mentioned situations, contact with the legal department is required.

If a lower land owner accepts surface water from the upland owner over and above the natural surface water, and the upland owner developed property in reliance on that acceptance, the lower land owner may be prevented from refusing to accept that water volume in the future. An example of this would be an owner of a cow pasture who accepts Department highway drainage into a pond on his land for use as a drinking area for his herd of cows. If he or a subsequent owner later decided to build a shopping center by the state roadway, he would continue to be responsible for the storage of the

water placed on his property by the Department.

C.3.3 STATUS QUO AND REASONABLY FORESEEABLE DEVELOPMENT

Two important items in highway drainage design for the Department to review from a legal perspective are the current natural state of the adjoining property to the highway and the reasonably foreseeable development that will occur in the area. The first concern may be addressed by creating current and/or reviewing historical drainage maps of the area. The second concern may be evaluated by reviewing local comprehensive zoning and stormwater management plans for the area in question. When feasible, the highway system design should be integrated with the local plans.

C.3.4 SUMMARIES OF CURRENT FLORIDA CASE LAW

The following summaries of the leading Florida cases on surface-water management should assist the drainage engineer in his review of problematic drainage areas:

In Koger Properties, Inc. v. Allen, 314 So.2d 792 (Fla. 1st DCA 1984), a developer had improved its property by constructing office buildings and parking areas, which gathered rainfall that had been previously absorbed by the earth and channeled it through storm drains that terminated at an opening directly in front of the lower land owner's (the plaintiff) property. The developer agreed that it would pipe the water through a 36-inch pipe under the road owned by the City of Tallahassee in front of the plaintiff's property, and the City agreed to carry the water from that point through a ditch which it agreed to enlarge.

The developer went ahead with construction without keeping the City advised of its progress, so that the City was unaware as to when it needed to improve its facilities.

Stormwater from a subsequent rainfall event was projected with great force from the terminus of the developer's storm drainage system at a point directly across the road from the plaintiff's home. The water overflowed the ditch, ran across the road in a small river, and flooded the plaintiff's property, causing great damage to his home.

A jury awarded the plaintiff compensatory and punitive damages against the developer for knowingly flooding the plaintiff's property. The jury found that the City was not responsible for any of the damages suffered by the plaintiff.

In Leon County v. Smith, 397 So.2d 362 (Fla. 1st DCA 1980), a developer of a subdivision designed a drainage system that would collect surface water and transport it east to west to a central ditch and then southerly through a ditch to the plaintiff/land owner's property. The outfall point for this water was along the northern boundary line of the land owner's property and no provisions were made for transporting the water across his land.

Later, the County accepted ownership of and responsibility for the drainage system. As homes were built in the subdivision, increasing amounts of stormwater entered the drainage system and discharged onto the plaintiff's property. The County then enclosed portions of the drainage system with pipes, and other drainage systems were connected to it. The velocity of the water flow was so increased by these actions that the drainage carved gullies 4 to 6 ft deep into the plaintiff's land. In addition, water continued flowing from the subdivision for days after the rain stopped and the area in and around the ditches remained a muddy ooze. Eventually, the flooding rendered the plaintiff's land useless.

The court held that, as a result of the County's action, the County had taken the plaintiff's property and was required to pay him just compensation for that property.

In Hanes v. Silgain, 448 So.2d 1130 (Fla. 1st DCA 1984), the plaintiff Hanes alleged that the manner in which Silgain Motel Corporation and Gulf Oil Corporation developed their property unreasonably diverted the natural flow of surface water to the detriment of the Hanes' property. Hanes further alleged that Silgain was negligent in designing and constructing an inadequate retention basin. Silgain then brought a third party action against the Department of Transportation alleging, among other things, that the Department negligently maintained a storm drainage system in such a manner as to wrongfully divert and disperse large volumes of surface waters onto Silgain's land in a concentrated stream.

The Department in turn brought a third party action seeking contribution against various land owners and users, asserting that the defendants developed their property in a manner that diverted and cast unreasonable quantities of surface water into the Department storm drainage system. The Department also alleged that such diversion overtaxed its drainage system, thereby rendering the defendants proportionately responsible for such damage as may have resulted to Silgain and Hanes from any excess drainage system discharge.

The Department's complaint was dismissed with prejudice. The appellate court upheld this dismissal, ruling that the Department was solely responsible for the maintenance of its drainage system and that commercial developments draining into this system did not jointly share in this responsibility.

In Department of Transportation v. Burnette, 384 So.2d 916 (Fla. 1st DCA 1980), the Department was enjoined from collecting water in pipes and ditches, and from diverting the water from its natural course and sending it onto Burnette's property.

The court found that the natural drainage path for land immediately surrounding U.S. 90 within a half mile west of Madison was northward under the highway and across property later occupied by North Florida Junior College. A culvert system was installed on the highway. Subsequently, those northward drainage courses were plugged, apparently to protect North Florida Junior College. This action caused ponding immediately south of the highway.

Then, in 1969, the Department allegedly changed the drainage by constructing and buying a ditch on an easement from the highway 500 ft south toward the northern boundary of the subject property. During the same project, the Department added more drainage to this system through a culvert along the south side of State Road 10, adding the runoff from 103 acres of improved land in municipal Madison. Burnette's engineer testified that an estimated 14 million gallons (43 acre-ft) of water from the City of Madison would be included in the drainage system and that under such conditions, 50 low acres of Burnette's land would be flooded and access would be limited on the remaining 50 acres.

The court concluded, however, that an action for inverse condemnation did not lie, because all beneficial uses to the property were not deprived and because the property had always been subject to intermittent flooding.

Stoer v. Ocala Mfg. Ice and Packing Co., 24 So.2d 579 (Fla. 1946), created an exception to upland owner liability in Florida in situations where the upland owner drains water into a natural watercourse. In such cases, an upland owner can increase the volume and velocity of the water flow into a natural watercourse without incurring any liability as long as the natural flow of water is not diverted or the watercourse is not overtaxed to the injury of the lower land owners.

C.4 POLLUTION CONTROL

Pollution control is becoming increasingly important in drainage law. The engineer faces a potential legal problem with environmental consequences at practically every point on a highway. There are three primary areas of highway drainage in which the Department must be especially concerned with regulation and liability:

- Dredge and fill
- Stormwater runoff
- Underground injection wells

The following is a general discussion of regulated activities that require permits from various agencies. It is not intended to be project- specific. Design permit assistance for a particular project should be obtained from the Bureau of Environment and the permit coordinator for the project.

The Department of Environmental Protection (DEP) is the chief pollution control agency in the state. Their jurisdiction over water pollution control extends to "waters of the state" as defined in Section 403.031, **Florida Statutes**:

"Rivers, lakes, streams, springs, impoundments, and all waters or bodies of water including fresh, brackish, saline, tidal surface, or underground."

It is not necessary for the area included in the waters of the state to be perpetually submerged in water; the DEP includes in its jurisdiction landward areas which are only covered by water some of the time. The boundaries of these areas are defined by the presence of plant species currently listed in **Rule 17-4.02, FAC**.

C.4.1 DREDGE AND FILL

All dredge and fill activities conducted in areas either in or connected to waters of the state are required to comply with water quality standards specified in **Rule 17-3, FAC**. The standards establish criteria that define the maximum level of listed pollutants allowable in a water body, determined by the water use classification for that body. Five levels of classification are used to delineate water use. For example, the Fenholloway River is designated as Class V, which allows commercial and industrial uses. The water quality standards allowable for that river are much lower than those for a Class I water source, which provides potable water, or for a Class II water source such as the Apalachee Bay where shellfish are harvested.

Pursuant to **Rule 17-4.28, FAC**, Dredge and Fill Permits must be obtained where dredge and fill activity is undertaken in:

1. Rivers and natural tributaries thereto
2. Streams and natural tributaries thereto
3. Bays, bayous, sounds, estuaries, and natural tributaries thereto
4. Natural lakes, except those owned entirely by one person (except for lakes of no more than 10 acres of water at the maximum average depth existing throughout the year)
5. The Atlantic Ocean and Gulf of Mexico out to the state territorial boundaries

Activities exempt from dredge and fill permitting requirements are:

1. The repair or replacement of existing pipes to original configurations for the purpose of discharge of stormwater runoff
2. The construction and maintenance of swales
3. The maintenance of existing drainage ditches to their original design configurations (except when listed plants begin to grow)

Within the limits of the DEP regulations, the Department would need to obtain dredge and fill permits when new roadbeds are constructed, when new drainage systems are constructed, and when new drainage systems involving underground piping are used.

For facilities which require use of state-owned lands, DEP usually issues an easement or dedication for DOT use of state-owned submerged land. Permit applications for groin or jetty construction, beach restoration, coastal revetments, or other similar coastal construction activities which will take place in or adjacent to tidal waters of the state may require a coastal construction permit.

C.4.2 STORMWATER RUNOFF

Pursuant to **Rule 17-25.01, FAC**, the DEP regulates discharge of untreated stormwater that could be a potential source of pollution to the state. This regulatory scheme is qualitative and quantitative. All stormwater discharges must meet the water quality standards of the class of water body the stormwater actually reaches. Additionally, the rule regulates stormwater by requiring retention or retention with filtration systems that allow separation of polluting substances by percolating the water into the ground. The DEP may delegate its regulatory authority to Water Management Districts, flood control districts, and local government entities. Control of stormwater runoff has been delegated to all Water Management Districts except the Northwest.

C.4.3 DRAINAGE WELLS

The Department's policy is to exhaust all reasonable alternative means of stormwater disposal before recommending the construction of a drainage well. This is because of the danger of polluting existing and future potable underground water supplies by the introduction of untreated surface waters and the uncertainty of satisfactory functioning of drainage wells, especially during extended periods of excess rainfall.

Certain local situations may dictate the use of drainage wells. Typically, this would occur on barrier islands and coastal locations, where the stormwater would be introduced into saltwater and could be effective in maintaining the existing fresh/saline water interface. Groundwater withdrawal is typically not permitted in these areas. However, due to the nature of drainage wells, specific design approval for the construction of drainage wells must be granted by the State Drainage Engineer on an individual project basis.

Drainage wells are considered by the DEP to be Class V, Group 5 wells, regulated under **Chapter 17-28, FAC**. Drainage well use and treatment of the surface water prior to discharge shall be consistent with these regulations. Some existing wells and all future wells drilled into potable or potentially potable aquifers should be recognized as requiring pretreatment of the surface water prior to discharge.

It is important to understand that **17-4.245,(2)(6), FAC**, specifically disallows discharges

through natural conduits such as sinkholes when there is a direct connection to certain classes of groundwater. The DEP has interpreted this to mean that a sinkhole is comparable to a drainage well when it provides a direct connection with Class G-I and Class G-II groundwater. Therefore, discharges to sinkholes that exhibit a direct connection to these classes of groundwater must be treated as discharges to a drainage well and require the same permit process.

C.5 WATER MANAGEMENT DISTRICTS

C.5.1 GENERAL

Prior to 1972, water management legislation in Florida had developed on a piecemeal basis. In that year, a comprehensive law was enacted to provide extensive protection and management of water resources throughout the state.

The ***Florida 1972 Water Resources Act***, Chapter 373, ***Florida Statutes***, provides a two-tiered administrative structure headed at the state level by the DEP. The DEP supervises five regional Water Management Districts designed to provide the diverse types of regulation needed in different areas of the state. These include the previously existing Central and Southern Florida Flood Control District, renamed the South Florida and the Southwest Florida Water Management Districts. Since these two districts had already been established and were authorized to levy ad valorem taxes to pay for their regulatory functions, they were promptly delegated full regulatory and permitting powers by the Department of Natural Resources (DNR), at that time the state-level regulatory agency. The three new districts established under the Act were the Suwannee River, St. Johns River, and Northwest Florida Water Management Districts.

C.5.2 BASIN BOARDS

Basin boards in the Water Management Districts handle administrative and planning functions in the particular basin, such as developing plans for secondary water control facilities and for water supply and transmission facilities for counties, municipalities, or regional water authorities. Basin boards do not exercise regulatory or permitting authority, but help to relieve the Water Management Districts of some of their administrative chores.

C.5.3 GOVERNING BOARDS

The governing boards of the Water Management Districts exercise broad statutory powers under Chapter 373, ***Florida Statutes***. In regard to water works, they are authorized to:

"Clean out, straighten, enlarge, or change the course of any waterway, natural or artificial, within or without the district; to provide such canals,

levees, dikes, dams, sluiceways, reservoirs, holding basins, floodways, pumping stations, bridges, highways, and other works and facilities which the board may deem necessary; establish, maintain, and regulate water levels in all canals, lakes, rivers, channels, reservoirs, streams, or other bodies of water owned or maintained by the district; cross any highway or railway with works of the district and to hold, control, and acquire by donation, lease, or purchase, or to condemn any land, public or private, needed for rights-of-way or other purposes; any way remove any building or other obstruction necessary for the construction, maintenance, and operation of the works; and to hold and have full control over the works and rights-of-way of the district."

These boards also establish rules and regulations related to water use, adopted after public hearing and subject to review by the Governor and Cabinet sitting as the Land and Water Adjudicatory Commission.

C.5.4 PERMITTING AUTHORITY

Permitting authority has been conferred on the Water Management Districts for artificial recharge projects or the intentional introduction of water into any underground formation; the construction, repair, and abandonment of water wells; the construction or alteration of dams, impoundments, reservoirs, and other water storage projects; the licensing and registration of water well contractors; and the hookup of local water works to the district's works. Such broad regulatory powers are consistent with the declared policy of the Florida Water Resources Act for the DEP "to the greatest extent practicable," to delegate conservation, protection, management, and control authority over state waters to the Water Management Districts.

C.5.5 INTERAGENCY COOPERATION

The DEP has been concerned most directly with water quality control while the Water Management Districts have been primarily involved with water quantity control. This has inevitably resulted in regulatory overlap and confusion, since water quality and water quantity considerations are seldom mutually exclusive. This regulatory overlap has made it necessary for the DEP and the Water Management Districts to work out an effective policy to avoid confusion and redundancy in the state's regulatory scheme.

Permitting criteria overlap between the DEP and the Districts often requires permit applicants to approach both agencies for action on a single proposed activity. The extent of this overlap depends largely on the extent to which a Water Management District has implemented its own permitting authority and established a broad range of rules and regulations for water resource management within its jurisdiction. Because they were in existence prior to enactment of the Water Resources Act, the two southern districts have experienced the major share of problems with overlapping responsibilities. Negotiations between the DEP and the Water Management Districts have led to

increased regulatory efficiency and greater convenience for the environmental permit applicant.

One cooperative approach has been the designation of a "primary" and "secondary" agency for specific permitting areas. Applicants would apply for a permit from the primary agency only; the secondary agency would provide input and guidance according to the terms of an interagency agreement. The DEP's Bureau of Water Resources has assigned a coordinator to attend District board meetings and act as a direct link between the agencies for the resolution of overlap problems. Also, joint quarterly meetings and the development of standardized rules have been helpful in promoting cooperation.

In dealing with highway drainage problems and issues, the Department engineer must be aware of the rules and regulations of the Water Management District in which the project is located. Since the Department issues permits for connections to the highway drainage system, it has become even more essential from the agency's standpoint to coordinate water storage plans and state resources, and to continue to preserve comprehensive water management plans.

C.6 WATER CONTROL DISTRICTS

Prior to July 1, 1980, the DEP, or a majority of the owners, or the owners of the majority of the acreage of any contiguous body of wet or overflowed lands or lands subject to overflow situated in one or more counties were empowered pursuant to Chapter 298, **Florida Statutes**, to form water control or drainage districts for agricultural purposes, or when conclusive to the public health, convenience, and welfare, or of public utility or benefit. On July 1, 1980, Chapter 298 was amended to provide that water control districts could only be created by special act of the legislature. The drainage districts in existence prior to that time were grand fathered in.

Drainage districts are governed by a board of supervisors who are elected by the land owners in the district. The DEP's voting rights in the elections are proportional to the extent of the acreage owned by the state in the districts. Presumably, that acreage would include Department of Transportation right-of-way existing in the district.

The board of supervisors is empowered to hire a chief engineer, who is responsible for the drainage works in the area, to adopt and carry out the plan of reclamation.

The Department of Community Affairs has recently been actively charged with the responsibility of coordinating growth management in the State, which will reflect on drainage facilities and projected area growth.

C.7 GOVERNMENT PROGRAMS THAT DEAL WITH SURFACE WATER RUNOFF

Under present law, municipalities have authority to provide for drainage of city streets and reclamation of wet, low, or overflowed lands within their jurisdiction. They may construct sewers and drains and may levy special assessments on benefited property owners to pay all or part of the costs of such works. Additionally, municipalities have the power of eminent domain to condemn property for these purposes. Thus, they have the means to deal directly with storm- and surface-water runoff problems.

The general zoning power which municipalities may exercise pursuant to Chapter 166, **Florida Statutes**, enables them to enact flood plain zoning ordinances. Such ordinances may simply require compliance with special building regulations or may exclude certain types of development in a designated flood plain. Enactment of such ordinances is another method by which municipalities can address runoff problems.

Most counties and municipalities have a drainage plan ordinance that requires submittal of a drainage plan for proposed developments. In addition, they commonly require that a drainage impact assessment be prepared and submitted if there is to be a change in the development site. Several local governments have ordinances restricting the amount of surface-water runoff that may be carried by a particular drainage system, or the amount of sediment transported by the runoff.

Many local ordinances also incorporate a flood plain regulation element or minimum elevations for old and new buildings to comply with the Federal National Flood Insurance Act of 1968 and the various current Flood Disaster Protection Acts. The virtues of flood control ordinances are multiple. As one study concluded:

"While such regulations are primarily designed to avoid direct flood damage to life and property, they yield clear benefits in the context of water quality maintenance as well. Overflows from septic tanks and combined sewers, for example, may be closely linked with improperly designed sewage and drainage systems within the flood plain. By preventing excessive encroachment of developments upon the flood plain, these special zoning laws also seem to retard rates of runoff and consequent water pollution from stream bank erosion and adjacent land surfaces."

Subdivision regulations relating to surface-water runoff control tend to be more detailed than local government ordinances, and often require submittal of a comprehensive drainage plan, approval of which is often a prerequisite for plat approval. Some regulations include runoff and rainfall criteria to which the proposed drainage system must conform, while others indicate permitted or preferred surface-water runoff control structures and techniques. Other provisions found in subdivision regulations include: a requirement that runoff from paved areas meet certain water quality standards; the encouragement or requirement of onsite retention of runoff; the regulation of grading

and erosion control methods; and a monitoring requirement for the discharge of surface-water runoff into lakes, streams, and canals.

Whether the Department must comply with these local rules and programs is a question that generates great doubt and confusion. The law is so uncertain that evaluation must be made on a case-by-case basis. There are some general principles that should be observed, however. First, although there are cases that state that Department power over roads and bridges is plenary, Section 339.155(2), **Florida Statutes**, requires that the Department, in adopting its statewide transportation plan, coordinate and be consistent with local government regulations "to the maximum extent feasible." Also, in developing the Florida Transportation Plan, the Department must take into account regional and local comprehensive plans and "the total environment of the community and region, including land uses, local stormwater management plans, and social and community values." Thus as a general rule, the Department should cooperate and comply with local regulations where such compliance would not be detrimental to the Department's interests.

However, the law is clear that the authority of a state agency prevails over local regulations when the regulations are in direct conflict with a statute or the subject of the local regulation has been preempted by the statutory scheme. In the absence of such a conflict or preemption, the courts balance the interests of the state agency versus the local governmental entity to determine whose interest is superior, and the superior interest prevails.

Appendix D

Acquisition of Real Property Rights

APPENDIX D

PART 1 - ACQUISITION OF REAL PROPERTY RIGHTS

D-1.1 PROPERTY PURCHASES

The Department currently purchases three types of real property interests:

- Drainage easements (permanent easements)
- Flooding and water storage easements (temporary easements)
- Fee simple title

By dividing the property needs into these categories, the Department is able to conform to requirements that empower it to take and make use of only as much real property as is necessary and best-suited to the project.

Drainage Easements

The Department acquires a permanent easement on property needed to ensure permanent maintenance of drainage facilities. Purchase of fee simple title is avoided, since the only public purpose for which the land is intended is drainage and drainage maintenance.

Under the drainage easement, the Department is empowered to remove any artificial or natural barriers which interfere with the use for which the easement was purchased. This includes fences, trees, shrubs, large root systems, or other obstacles to proper drainage or maintenance. The Department cannot be held legally accountable if actions taken to prevent hindrances to usage damage or destroy natural growth.

In many developed areas of the state, parking facilities have been built over drainage easements, with approval contingent on installation of piping that continues to satisfy the Department's objectives. The following conditions also apply:

- The design must be for ground level parking facilities.
- The Department will not be responsible for the cost of piping needed to maintain Department standards for the easement.
- The costs borne by the fee simple owner include design, construction, and the Department's inspection activities.

Since maintenance or roadway reconstruction activities may require removal of some or all of the parking facility, the Department should make sure that any agreement specifically releases it from any liability for physical damage to or loss of use of the facility.

Flooding and Water Storage Easements

On occasion, water from heavy rainfall events or non-permitted drainage hookups will exceed the design limits of the highway drainage system, leaving the closed system and flowing onto land the Department does not own. When areas where this may occur can be determined in advance and when such flooding occurs under a limited set of conditions and is temporary in nature, the Department may acquire a temporary flooding easement. This gives the Department flood rights, allowing temporary use of private property to ease flooding. The flood easement may or may not define conditions under which flooding may occur and the elevation water would be expected to reach under those conditions. Emphasis is placed on public safety and cost when negotiating for the easement.

Flood rights are usually purchased on land in a natural state, which already floods under certain weather conditions from non-highway sources. An example of this type of land is a land-locked natural basin, such as those found in northern Florida.

To provide a retention or detention storage area for discharging water from the closed highway drainage system, the Department may purchase either a temporary or permanent water storage easement. This storage area may allow the water to be transported to waterways of the state or to evaporate or percolate into the soil over time, and may be in response to certain temporary conditions or can become part of the drainage system design.

Many current comprehensive county zoning plans require that developers provide storage for runoff that occurs from land development. Since these storage areas are generally available to public and private entities, the Department should consider their use whenever possible and only purchase storage rights needed for roadway drainage when no other alternative is available.

Fee Simple Title

The decision to purchase fee simple title rather than an easement to real property should be made on a case-by-case basis that evaluates the benefits in terms of public safety and convenience against the additional cost. A typical example would be property containing open drainage ditches with sufficient depth or velocity to pose a clear and present hazard to the public. Possession of fee simple title would allow the Department to fence the property and otherwise minimize potential dangers in accordance with state safety standards.

D-1.2 PROPERTY EXCHANGES

As a general rule, either rights-of-way or easements can be exchanged in kind between the Department and a property owner when the exchange is requested by the property

owner and no additional costs or inconveniences will be borne by the Department as a result of the exchange. All costs of necessary reconstruction, legal services, documentation, or recording the exchange will be borne by the property owner. Before the exchange is approved, the Department must evaluate the potential for use, liabilities, and increased maintenance engendered by the exchange.

D-1.3 CRITERIA FOR ESTABLISHING PROPERTY INTERESTS

This **Manual** establishes the minimum criteria for establishing property interests for drainage purposes, including width and alignments. A sufficient additional allowance should be provided for construction and maintenance requirements.

PART 2 - PROTECTIVE TREATMENT

D-2.1 PURPOSE

Drainage designs shall be reviewed to determine if some form of protective treatment will be required to prevent entry to long or submerged storm drain systems, steep ditches, or water control facilities. Such entry would present a hazard to children and, to a lesser extent, all persons. If other modifications, such as landscaping or providing flat slopes, can eliminate the potential hazard and thus the need for protective treatment, they should be considered first. Areas provided for retention and detention, for example, can often be effectively integrated into parks or other green spaces.

Vehicular and pedestrian safety are attained by differing protective treatments, often requiring the designer to make a compromise in which one type of protection is more completely realized than the other. In such cases, an evaluation should be made of the relative risks and dangers involved to provide the design that gives the best balance. It must be remembered that the function of the drainage feature will be essentially in conflict with total safety, and that only a reduction rather than elimination of all risk is possible.

D-2.2 TYPES

The three basic types of protective treatment used by the Department are:

<u>Feature</u>	<u>Typical Use</u>
Grates	To prevent persons from being swept into long or submerged drainage systems.
Guards	To prevent entry into long sewer systems under no-storm conditions, to prevent persons from being trapped.

Fences To prevent entry into areas of unexpected deep standing water or high velocity water flow, or in areas where grates or guards are warranted but are unsuitable for other reasons.

D-2.3 GENERAL CRITERIA FOR USE

When determining the type and extent of protective treatment, the following considerations should be reviewed:

The nature and frequency of the presence of children in the area, e.g., proximity to schools, school routes, and parks, should be established.

Highway access status should be determined. Protective treatment is usually not warranted within a limited access highway; however, drainage facilities located outside the limited access area or adjacent to a limited access highway should be considered unlimited access facilities.

Adequate debris and access control would be required on all inlet points if guards or grates are used at outlet ends.

Hydraulic determinations such as depth and velocity should be based on a 25-year rainfall event.

The hydraulic function of the drainage facility should be checked and adjusted so the protective treatment will not cause a reduction in its effectiveness.

Use of a grate may cause debris or persons to be trapped against the hydraulic opening. Grates for major structures should be designed in a manner that allows items to be carried up by increasing flood stages.

Use of a guard may result in a person being pinned against it. A guard is usually used on outlet ends.

A fence may capture excessive amounts of debris, which could possibly result in its destruction and subsequent obstruction of the culvert. The location and construction of a fence shall reflect the effect of debris-induced force.