

**SIGNAL PLACEMENT AT RAILROAD CROSSING  
(2 - LANE DESIGN)**

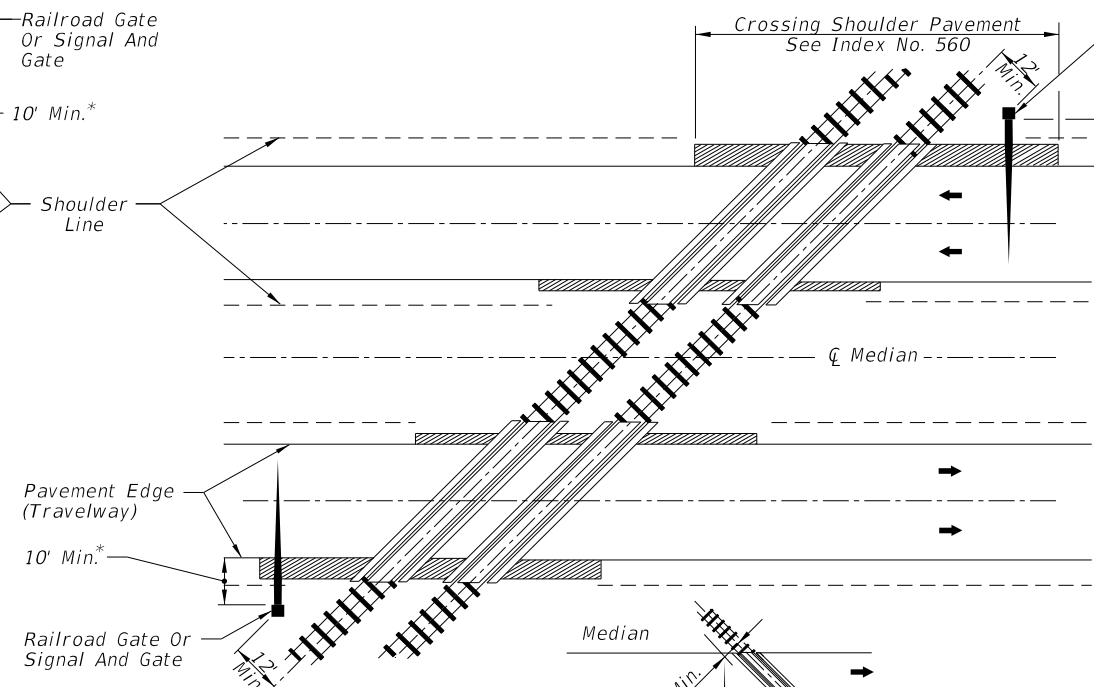

**SIGNAL PLACEMENT AT RAILROAD CROSSING  
(4 - LANE DESIGN)**

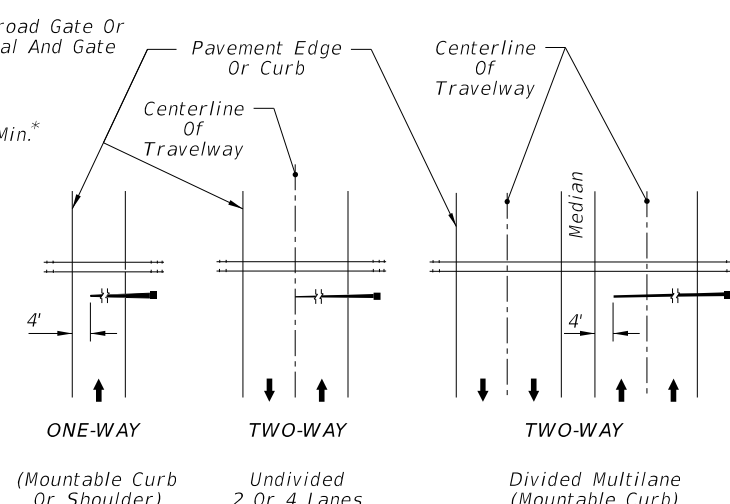

**FIGURE 1**  
Note: Arrows denote direction of travel not pavement markings. Gate Length Requirements See Note 5 Sheet 3.

**GENERAL NOTES:**

- No guardrail is proposed for signals; however, some form of impact attenuation device may be specified for certain locations.
- Advance flasher to be installed when and if called for in plans or specifications.
- Top of foundation shall be no higher than 4" above finished shoulder grade.
- Type of traffic control device
  - Flashing warning devices
  - Flashing warning devices with cantilever
  - Flashing warning devices with gate
  - Flashing warning devices with cantilever and gate
  - Gate
- Class of traffic control devices (Not Shown)
  - 2 Quadrant flashing warning devices-one track
  - 2 Quadrant flashing warning devices-multiple tracks
  - 2 Quadrant flashing warning devices and gates-one track
  - 2 Quadrant flashing warning devices and gates-multiple tracks
  - 3-4 Quadrant flashing warning devices and gates-one track
  - 2-4 Quadrant flashing warning devices and gates-multiple tracks

Note: Two separate foundations may be required (one for signals, one for gate), depending on type of equipment used.

\* When 10' is deemed impracticable the control device can be located as close as 2' from the edge of a paved shoulder but not less than 6' from the edge of the near traffic lane.

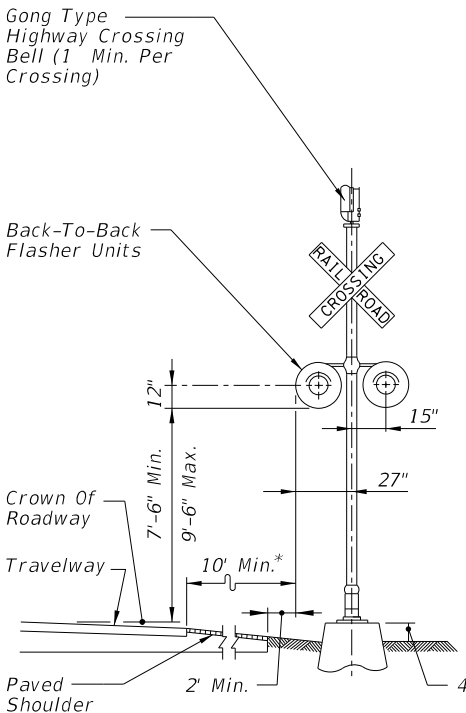

**TYPE I**

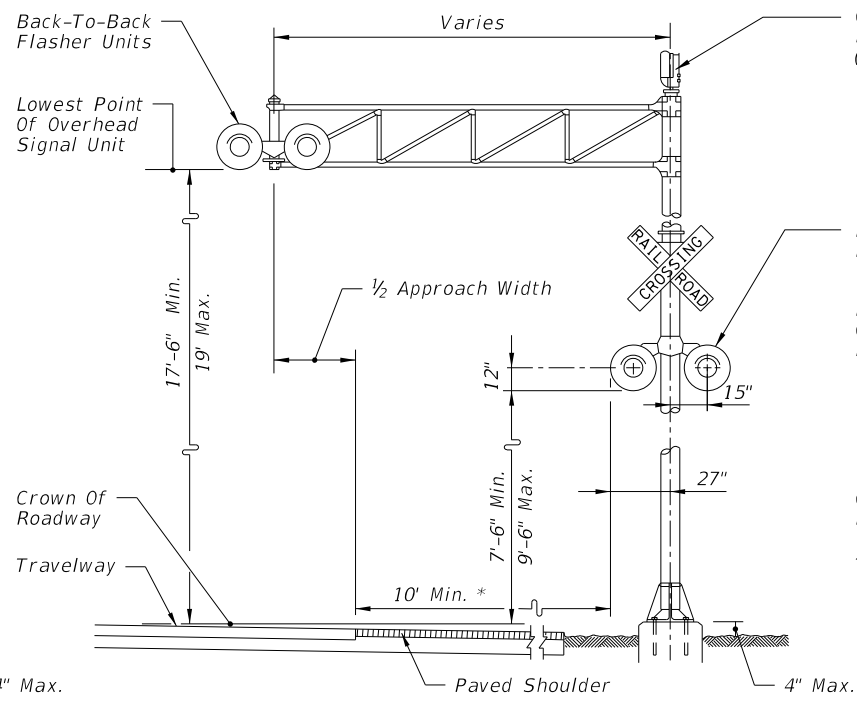

**TYPE II**

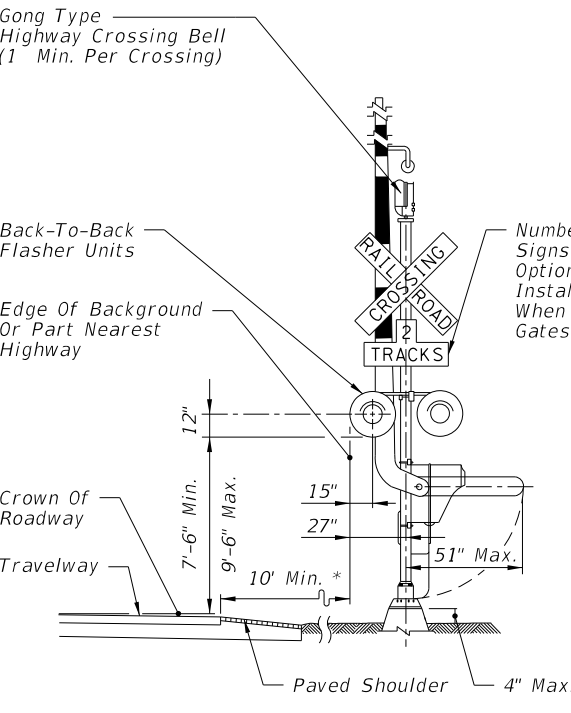

**TYPE III AND TYPE V**

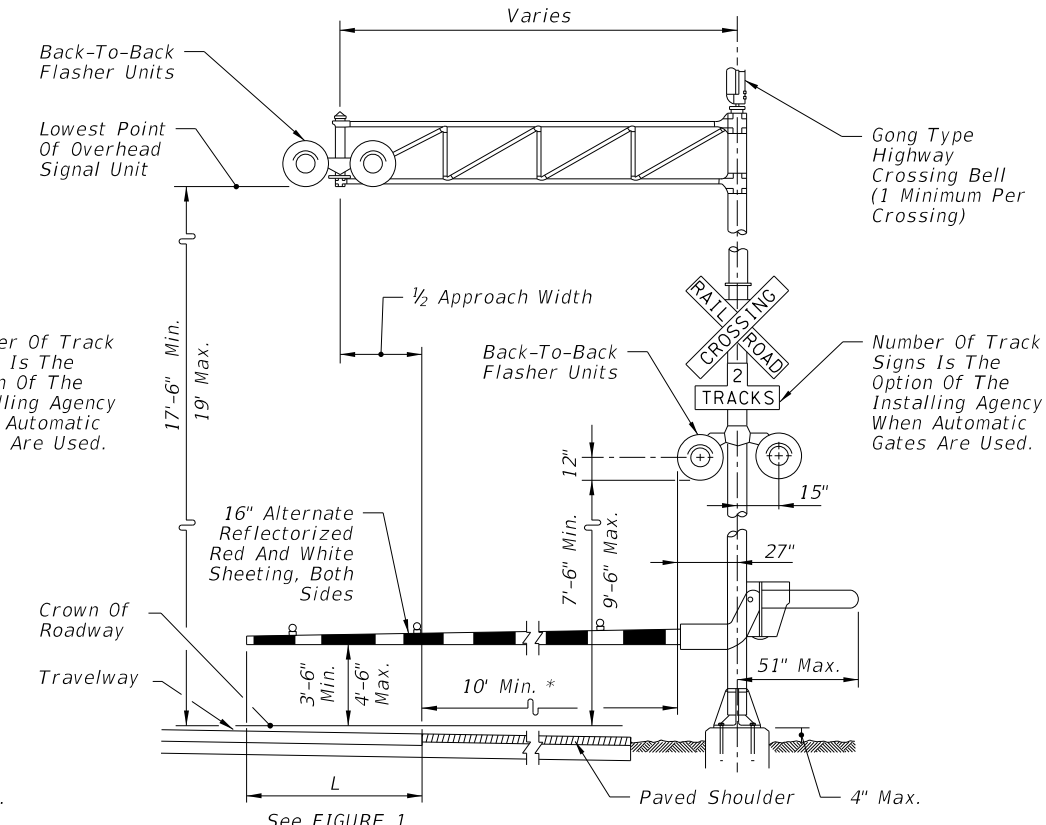

**TYPE IV AND TYPE VI**

**TRAFFIC CONTROL DEVICES FOR FLUSH SHOULDER ROADWAY**

11/9/2016 9:22:08 AM

LAST REVISION 11/07/16	REVISION	DESCRIPTION:	FY 2017-18 DESIGN STANDARDS	RAILROAD GRADE CROSSING TRAFFIC CONTROL DEVICES	INDEX NO. 17882	SHEET NO. 1 of 4
---------------------------	----------	--------------	--------------------------------	--	--------------------	---------------------

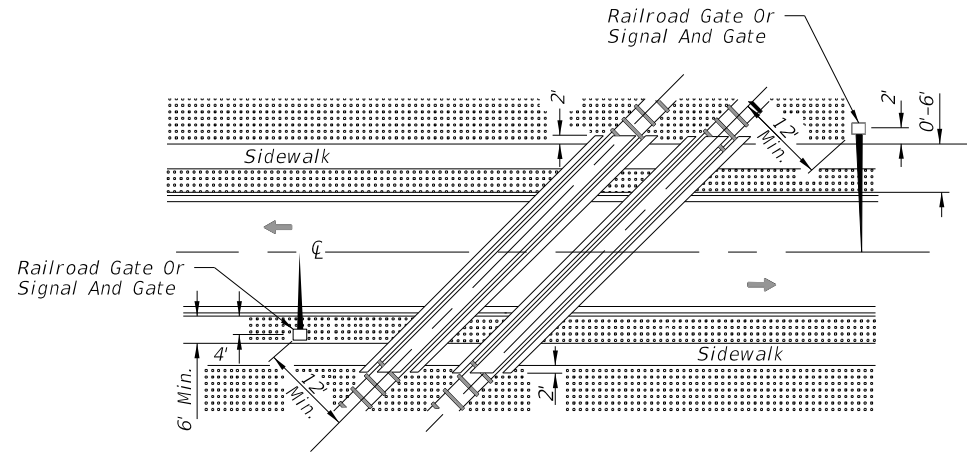

ACUTE ANGLE (AND RIGHT ANGLE)

SIGNAL PLACEMENT AT RAILROAD CROSSING  
(2 LANES, CURB & GUTTER)

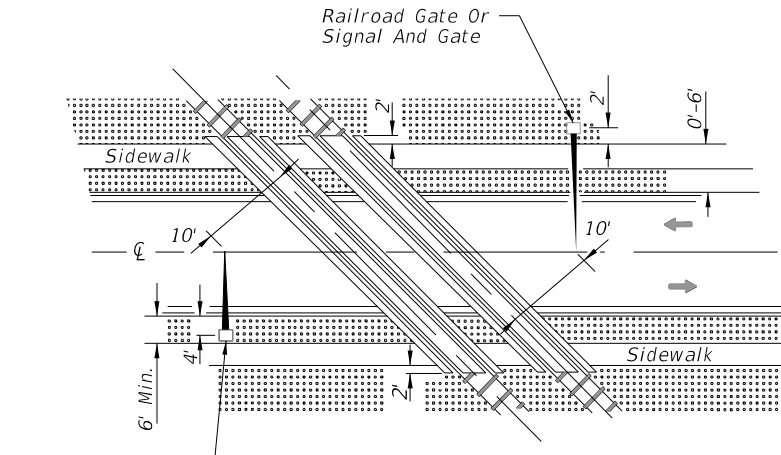

OBTUSE ANGLE

SIGNAL PLACEMENT AT RAILROAD CROSSING  
(2 LANES, CURB & GUTTER)

NOTES:

1. The location of flashing warning devices and stop lines shall be established based on future (or present) installation of gate with appropriate track clearances.
2. Where plans call for railroad traffic control devices to be installed in curbed medians, the minimum median width shall be 12'-6".
3. Location of railroad traffic control device is based on the distance available between face of curb & sidewalk. 0' to 6' - Locate device outside sidewalk. Over 6' - Locate device between face of curb and sidewalk.
4. Stop line to be perpendicular to edge of roadway, approx. 15' from nearest rail; or 8' from and parallel to gate when present.
5. When a cantilevered-arm flashing warning device is used, the minimum vertical clearance shall be 17'-6" from above the Crown of Roadway to the Lowest Point of the Overhead Signal Unit.

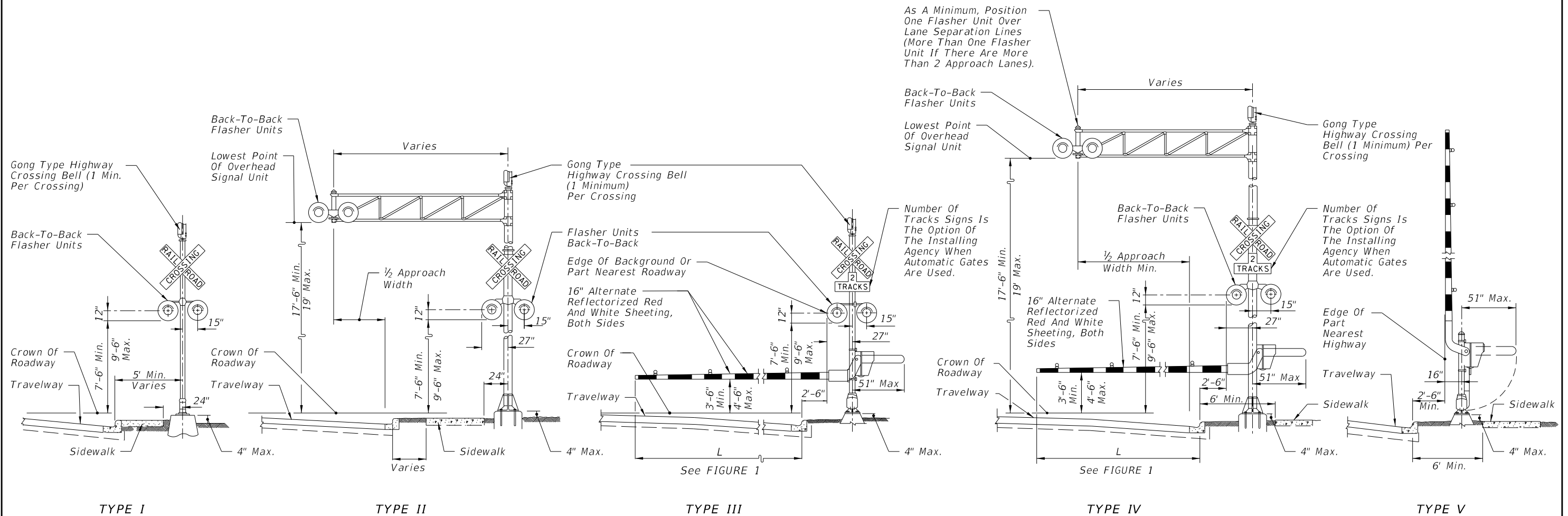

TYPE I

TYPE II

TYPE III

TYPE IV

TYPE V

TRAFFIC CONTROL DEVICES FOR CURBED ROADWAY

11/9/2016 9:22:11 AM

LAST REVISION 11/07/16	DESCRIPTION:
---------------------------	--------------



FY 2017-18  
DESIGN STANDARDS

RAILROAD GRADE CROSSING  
TRAFFIC CONTROL DEVICES

INDEX NO.  
17882

SHEET NO.  
2 of 4

**RAILROAD CROSSING AT TWO (2)-LANE ROADWAY**

**RAILROAD CROSSING AT MULTILANE ROADWAY**

**RELATIVE LOCATION OF CROSSING TRAFFIC CONTROL DEVICES**

Stop Bar Perpendicular to Edge Of Travel Way Or 8' From & Parallel To Gate When Present.

Stop Bar Perpendicular to Edge Of Travel Way Or 8' From & Parallel To Gate When Present.

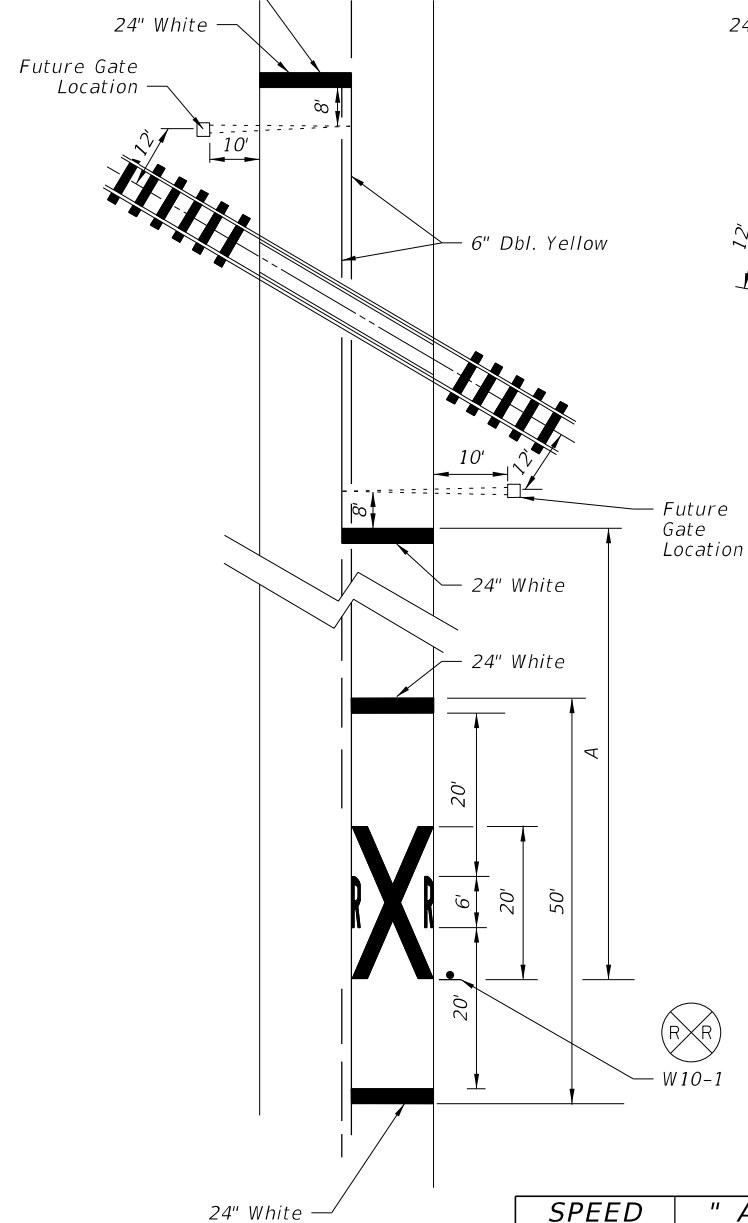

SPEED (mph)	" A " (ft)
60	400
55	325
50	250
45	175
40	125
35	100
URBAN	85 MIN.

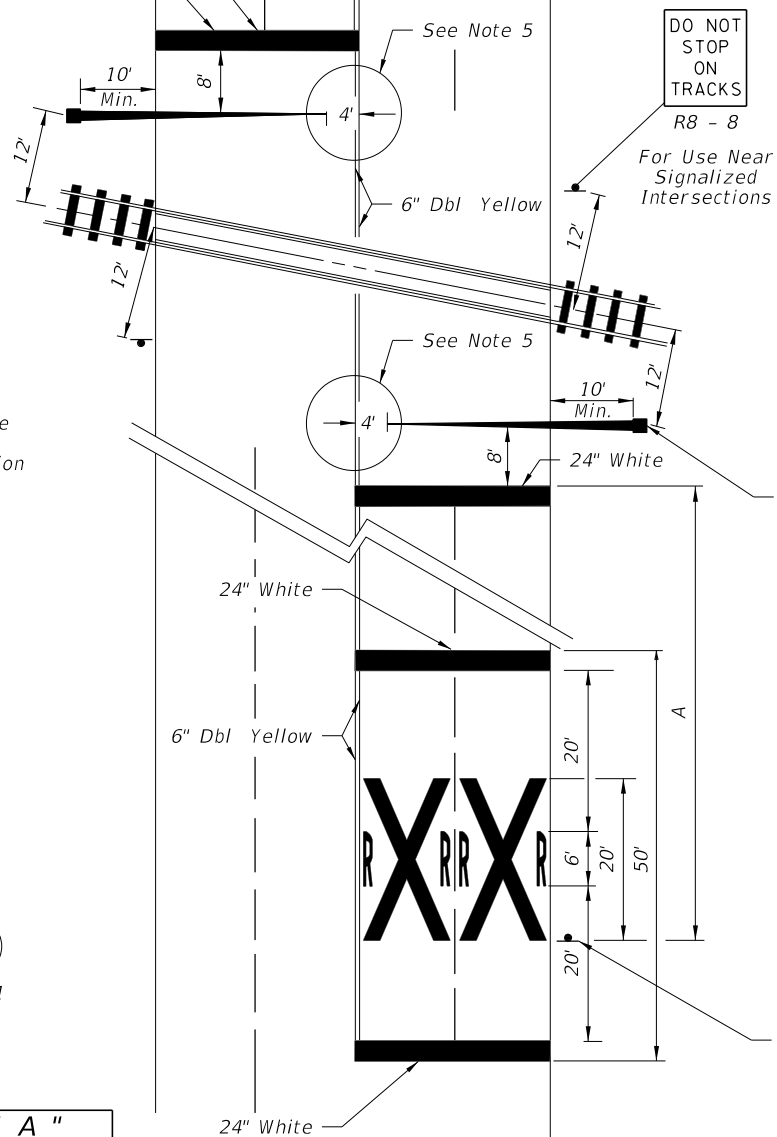

DO NOT STOP ON TRACKS

R8 - 8 For Use Near Signalized Intersections

Railroad Protection Device Is Not To Be Located Within 12' Of The RR Center Line.

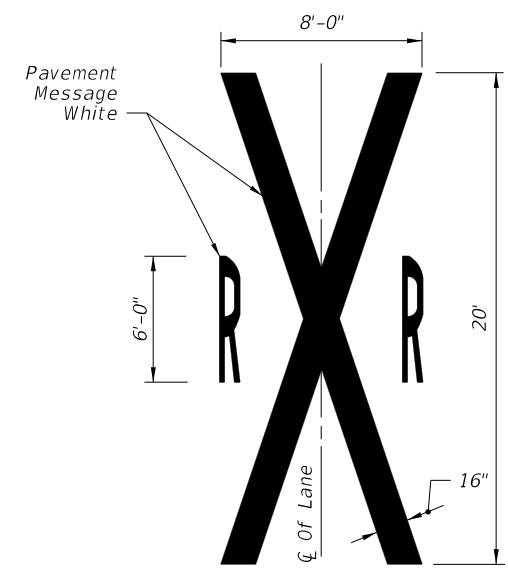
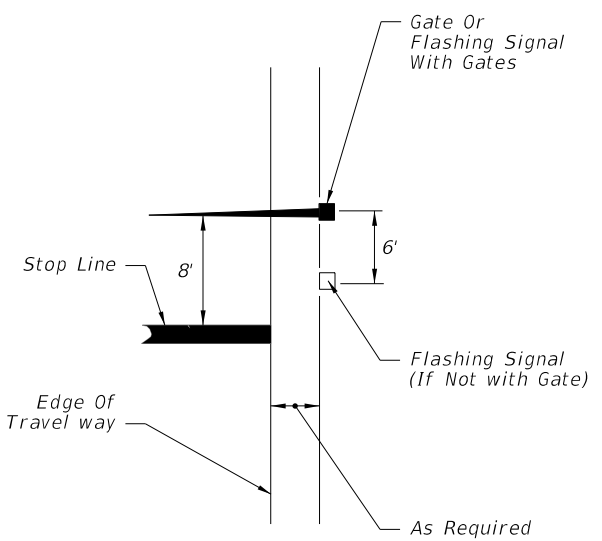

**NOTES:**

- When computing pavement message, quantities do not include traverse lines.
- Placement of sign W10-1 in a residential or business district, where low speeds are prevalent, the W10-1 sign may be placed a minimum distance of 100' from the crossing. Where street intersections occur between the RR pavement message and the tracks an additional W10-1 sign and additional pavement message should be used.
- A portion of the pavement markings symbol should be directly opposite the W10-1 sign.
- Recommended location for FTP-61-06 or FTP-62-06 signs, 100' urban and 300' rural. See Index 17355 for sign details.
- Gate Length Requirements:  
For Two-way undivided sections:  
The gate should extend to within 1' of the center line. On multiple approaches the maximum gate length may not reach to within 1' of the center line. For those cases, the distance from the gate to the center line shall be a maximum of 4'.  
For one-way or divided sections:  
The gate shall be of sufficient length such that the distance from the gate tip to the inside edge of pavement is a maximum of 4'.

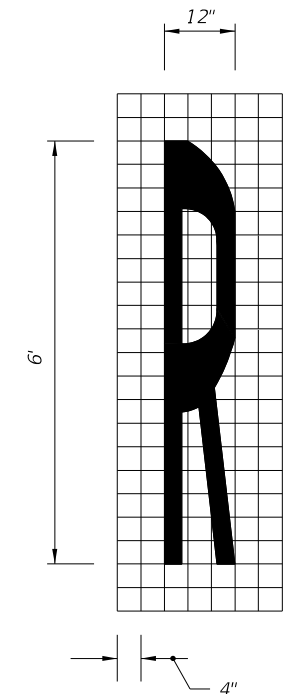

10/14/2016 1:34:12 PM

LAST REVISION	DESCRIPTION:
07/01/10	

**FDOT** FY 2017-18 DESIGN STANDARDS

**RAILROAD GRADE CROSSING TRAFFIC CONTROL DEVICES**

INDEX NO. 17882

SHEET NO. 3 of 4

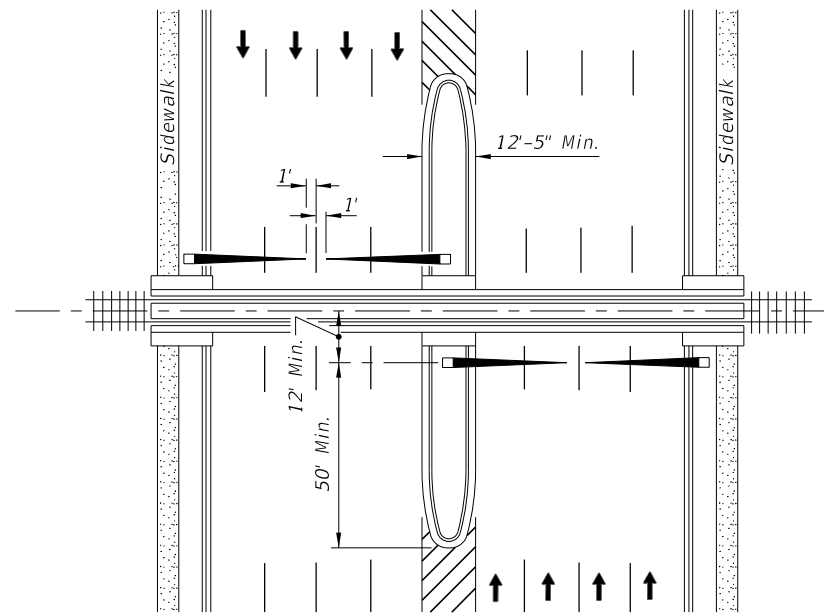
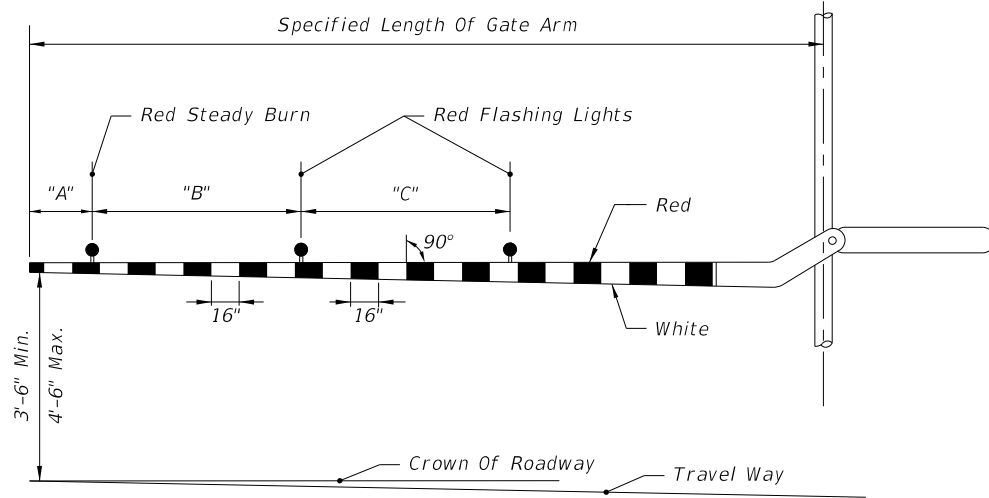

PLAN

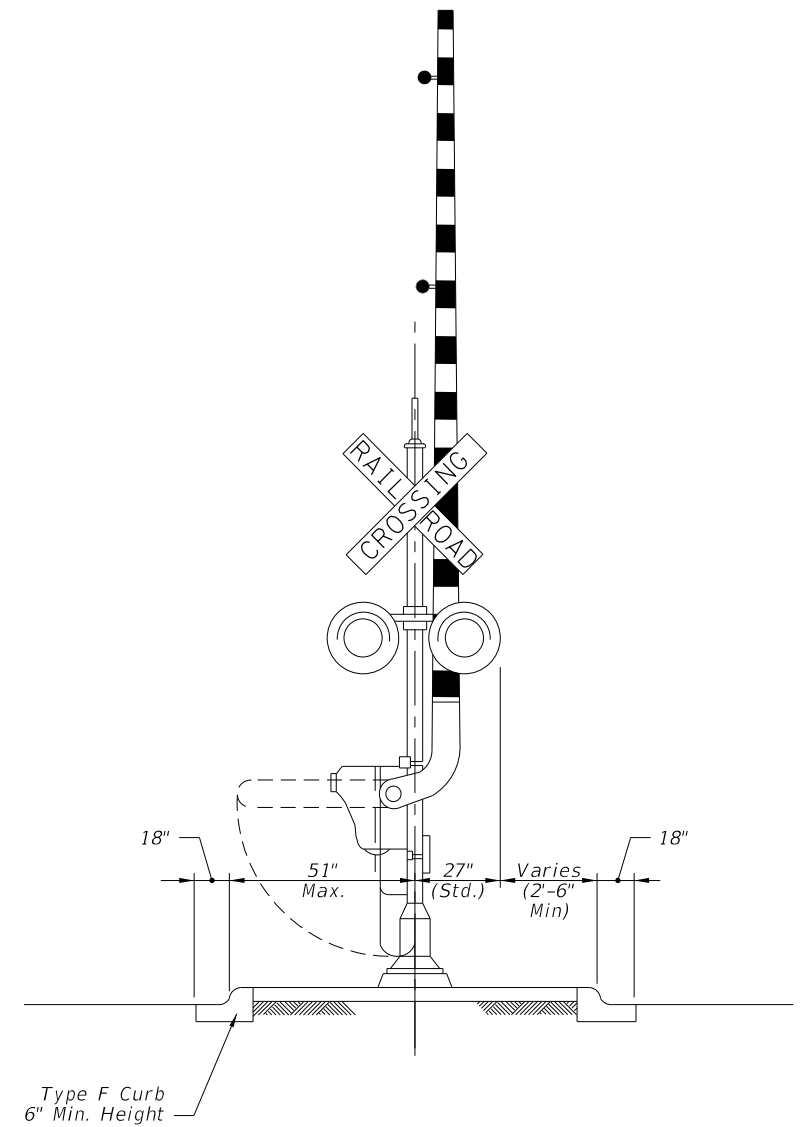

MEDIAN SECTION AT SIGNAL GATES

RAILROAD GATE ARM LIGHT SPACING

Specified Length Of Gate Arm	Dimension "A"	Dimension "B"	Dimension "C"
14 Ft.	6"	36"	5'
15 Ft.	18"	36"	5'
16-17 Ft.	24"	36"	5'
18-19 Ft.	28"	41"	5'
20-23 Ft.	28"	4'	5'
24-28 Ft.	28"	5'	5'
29-31 Ft.	36"	6'	6'
32-34 Ft.	36"	7'	7'
35-37 Ft.	36"	9'	9'
38 And Over	36"	10'	10'

NOTE:  
For additional information see the "Manual On Uniform Traffic Control Devices", Part 8; The "Traffic Control Handbook", Part VIII; and AASHTO "A Policy On Geometric Design Of Streets And Highways".

MEDIAN SIGNAL GATES FOR  
MULTILANE UNDIVIDED URBAN SECTIONS  
(THREE OR MORE DRIVING LANES IN ONE DIRECTION, 45 MPH OR LESS)

10/14/2016 1:34:15 PM