

HIGHMAST LIGHTING NOTES:

1. Poles are designed to support the following:
 - A. One (1) cylindrical head assembly with a maximum effective projected area of 6 sf and 340 lbs (Max.)
 - B. Eight (8) cylindrical luminaires with a maximum effective projected are of 1.5 sf and 77 lbs each.
2. Shop Drawings: This Index is considered fully detailed, only submit shop drawings for minor modifications not detailed in the Plans.
3. High Mast Structure Materials:
 - A. Poles and Backing Rings:
 - a. Less than 3/16": ASTM A1011 Grade 50, 55, 60 or 65
 - b. Greater than or equal to 3/16": ASTM A572 Grade 50, 55, 60 or 65
 - c. ASTM A595 Grade A (55 ksi yield) or Grade B (60 ksi yield)
 - B. Steel Plates: ASTM A709 or ASTM A36
 - C. Pole Caps: ASTM A1011 Grade 50, 55, 60, or 65 or ASTM B209
 - D. Weld Metal: E70XX
 - E. Stainless Steel Screws: AISI 316
 - F. Anchor Bolts, Nuts and Washers:
 - a. Anchor Bolts: ASTM F1554 Grade 55
 - b. Nuts: ASTM A563 Grade A Heavy-Hex (5 per anchor bolt)
 - c. Plate Washer: ASTM A36 (2 per anchor bolt)
 - G. Nut Covers: ASTM B26 (319-F)
 - H. Concrete: Class IV (Drilled Shaft)
 - I. Reinforcing Steel: Specification Section 415
4. Fabrication:
 - A. Welding: Specification Section 460-6.4
 - B. Poles:
 - a. Round or 16-Sided (Min.)
 - b. Pole Taper: Diameter changing at 0.14 inches per foot.
 - c. Two longitudinal seam welds (Max.).
 - d. Longitudinal seam welds within 6" of pole to base must be complete penetration welds.
 - e. Longitudinal seam welds at telescopic field joints must be complete penetration welds for the splice length plus 6".
 - f. Circumferentially welded pole shaft, butt splices and laminated pole shafts are not permitted.
 - C. Holes for Anchor Bolts: Anchor Bolt diameter plus 1/2" (Max.), prior to galvanizing.
 - D. Hot Dip Galvanize after Fabrication.
 - E. Identification Tag: (Submit details for approval.)
 - a. 2"x 4" (Max.) aluminum identification tag.
 - b. Locate on the inside of the pole and visible from the handhole.
 - c. Secure to pole with 1/8" diameter stainless steel rivets or screws.
 - d. Include the following information on the ID Tag:
 1. Financial Project ID
 2. Pole Type
 3. Pole height
 4. Manufacturers' Name
 5. Fy of Steel
 6. Base Wall Thickness
5. Coating:
 - A. Galvanize Anchor Bolts, Nuts and Washers: ASTM F2329
 - B. Hot Dip Galvanize all other steel items: ASTM A123
6. Construction:
 - A. Foundation: Specification Section 455 Drilled Shaft, except that payment is included in the cost of the Structure.
 - B. After Installation: Place wire screen between top of foundation and bottom of baseplate in accordance with Specification Section 649-6.

10/14/2016 10:54:47 AM

STANDARD POLE DESIGN NOTES

LAST REVISION 11/01/16	REVISION	DESCRIPTION:	 FY 2017-18 DESIGN STANDARDS	HIGH MAST LIGHTING	INDEX NO. 17502	SHEET NO. 1 of 6
------------------------------	----------	--------------	--	---------------------------	-----------------------	------------------------

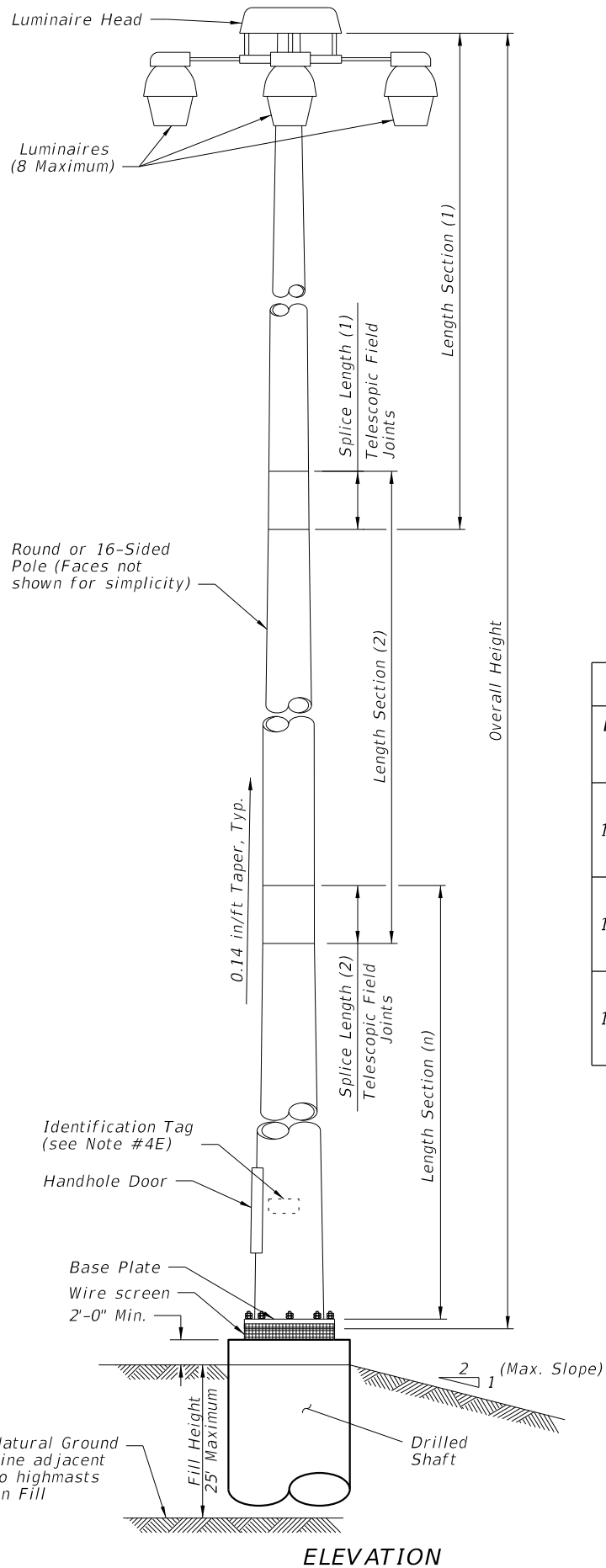

POLE DESIGN TABLE*													
Design Wind Speed	Pole Overall Height (ft)	SECTION 1 (TOP)				SECTION 2				SECTION 3			
		Length	Wall Thickness (in.)	Minimum Splice L.	Base Dia. (in.)	Length	Wall Thickness (in.)	Minimum Splice L.	Base Dia. (in.)	Length	Wall Thickness (in.)	Minimum Splice L.	Base Dia. (in.)
130 mph	80	41'-0"	0.250	2'-0"	11	42'-0"	0.250	--	16	--	--	--	--
	100	23'-0"	0.179	2'-0"	10	41'-0"	0.250	2'-6"	15	43'-0"	0.250	--	20
	120	41'-0"	0.250	2'-0"	12	43'-0"	0.250	2'-9"	17	43'-0"	0.313	--	22
150 mph	80	41'-0"	0.250	2'-0"	11	42'-0"	0.313	--	16	--	--	--	--
	100	23'-0"	0.179	2'-0"	10	41'-0"	0.250	2'-6"	15	43'-0"	0.313	--	20
	120	41'-0"	0.250	2'-6"	16	43'-0"	0.250	3'-0"	21	44'-0"	0.375	--	26
170 mph	80	40'-0"	0.250	2'-3"	13	43'-0"	0.313	--	18	--	--	--	--
	100	23'-0"	0.250	2'-0"	11	42'-0"	0.313	2'-6"	16	44'-0"	0.375	--	21
	120	41'-0"	0.250	3'-0"	18	44'-0"	0.313	3'-6"	23	45'-0"	0.375	--	28

* Diameter Measured Flat to Flat

BASE PLATE AND BOLTS DESIGN TABLE							
Design Wind Speed	Pole Overall Height (ft)	Base Plate Diameter (in.)	Base Plate Thickness (in.)	Bolt Circle (in.)	No. Bolts	Bolt Diameter (in.)	Bolt Embedment (in.)
130 mph	80	30.0	3.0	23.0	8	1.75	38
	100	34.0	3.0	27.0	8	1.75	42
	120	38.0	3.0	30.0	8	2.00	48
150 mph	80	30.0	3.0	23.0	8	1.75	43
	100	36.0	3.0	28.0	8	2.00	47
	120	44.0	3.875	35.0	8	2.25	52
170 mph	80	32.0	3.0	25.0	8	1.75	47
	100	37.0	3.25	29.0	8	2.00	54
	120	46.0	3.875	37.0	10	2.25	58

SHAFT DESIGN TABLE				
Design Wind Speed	Pole Overall Height (ft)	Shaft Diameter	Shaft Length	Longitudinal Reinforcement
130 mph	80	4'-0"	13'-0"	14- #11
	100	4'-6"	14'-0"	16- #11
	120	4'-6"	16'-0"	16- #11
150 mph	80	4'-0"	14'-0"	14- #11
	100	4'-6"	16'-0"	16- #11
	120	5'-0"	18'-0"	18- #11
170 mph	80	4'-6"	15'-0"	16- #11
	100	4'-6"	17'-0"	16- #11
	120	5'-0"	20'-0"	18- #11

NOTE: Foundation are assumed to be in level ground. For Foundation with slopes 5H:1V and greater, increase the shaft depth in accordance with the additional shaft depth due to ground slope table. For slope or diameter values in between those shown in the table, use the higher value.

ADDITIONAL SHAFT DEPTH DUE TO GROUND SLOPE (ft)		
Ground Slope	Drilled Shaft Diameter (ft)	
	4	5
5H:1V	3	4
4H:1V	4	5
3H:1V	5	6
2H:1V	7	9

10/14/2016 10:54:49 AM

POLE DESIGN TABLES

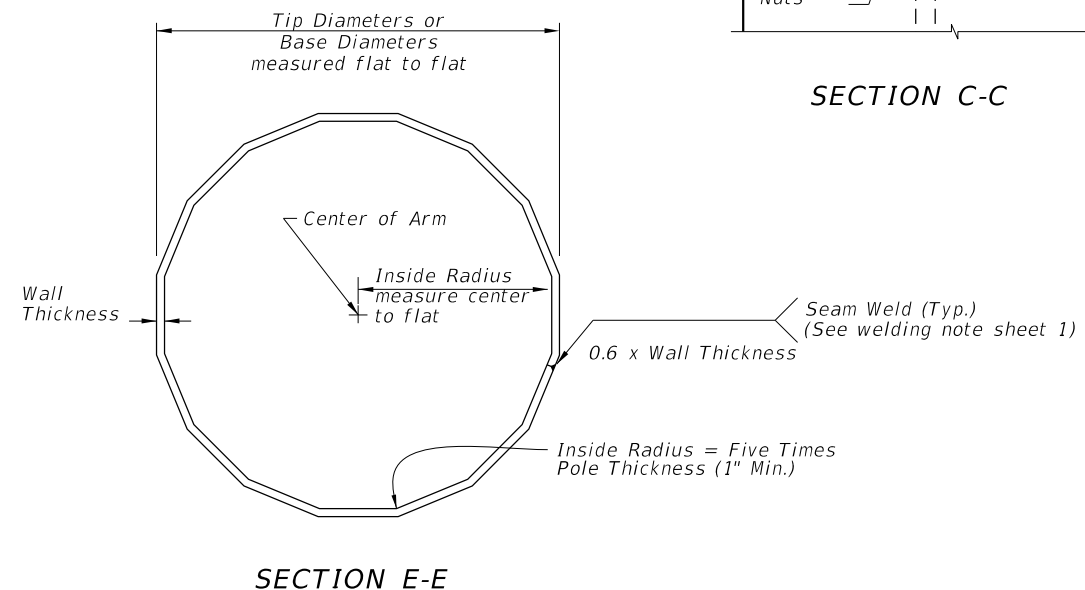
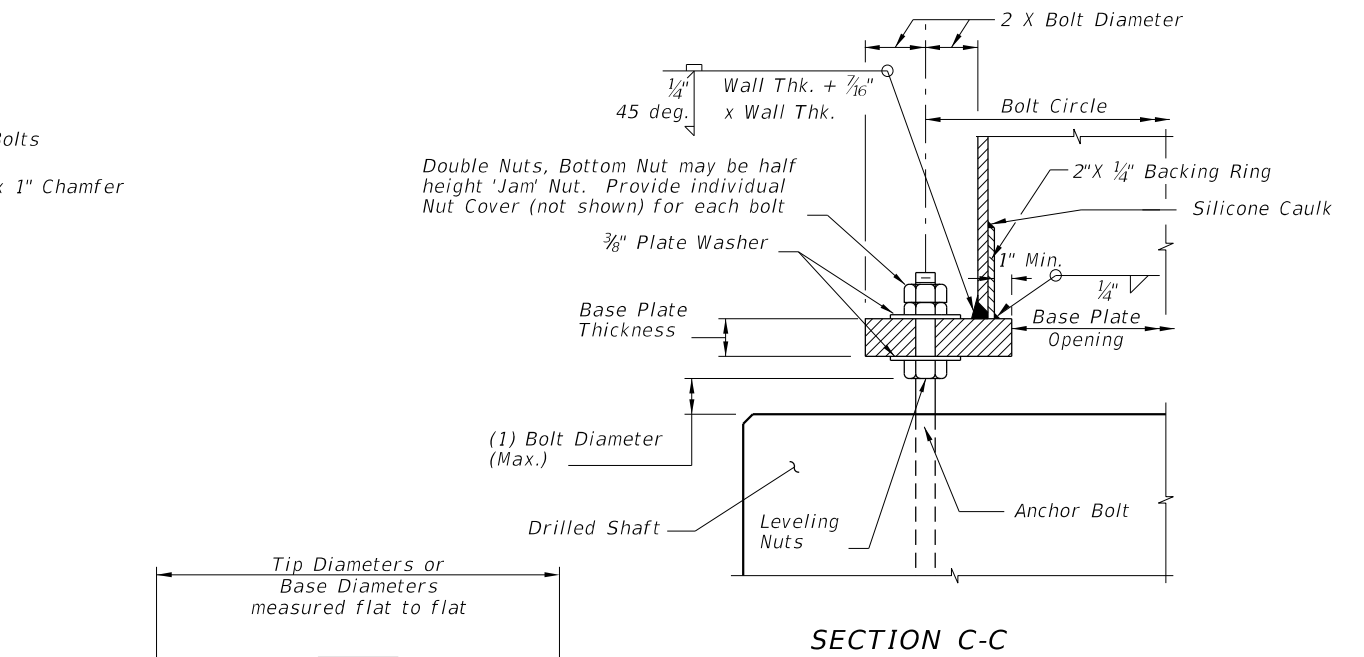
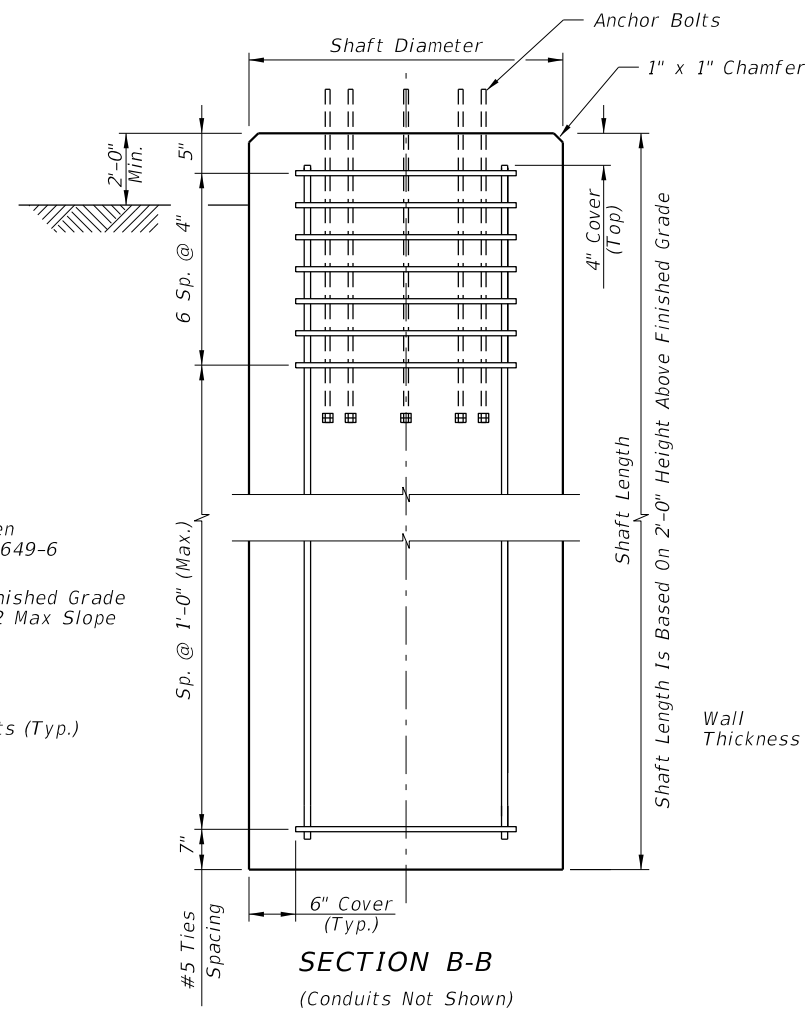
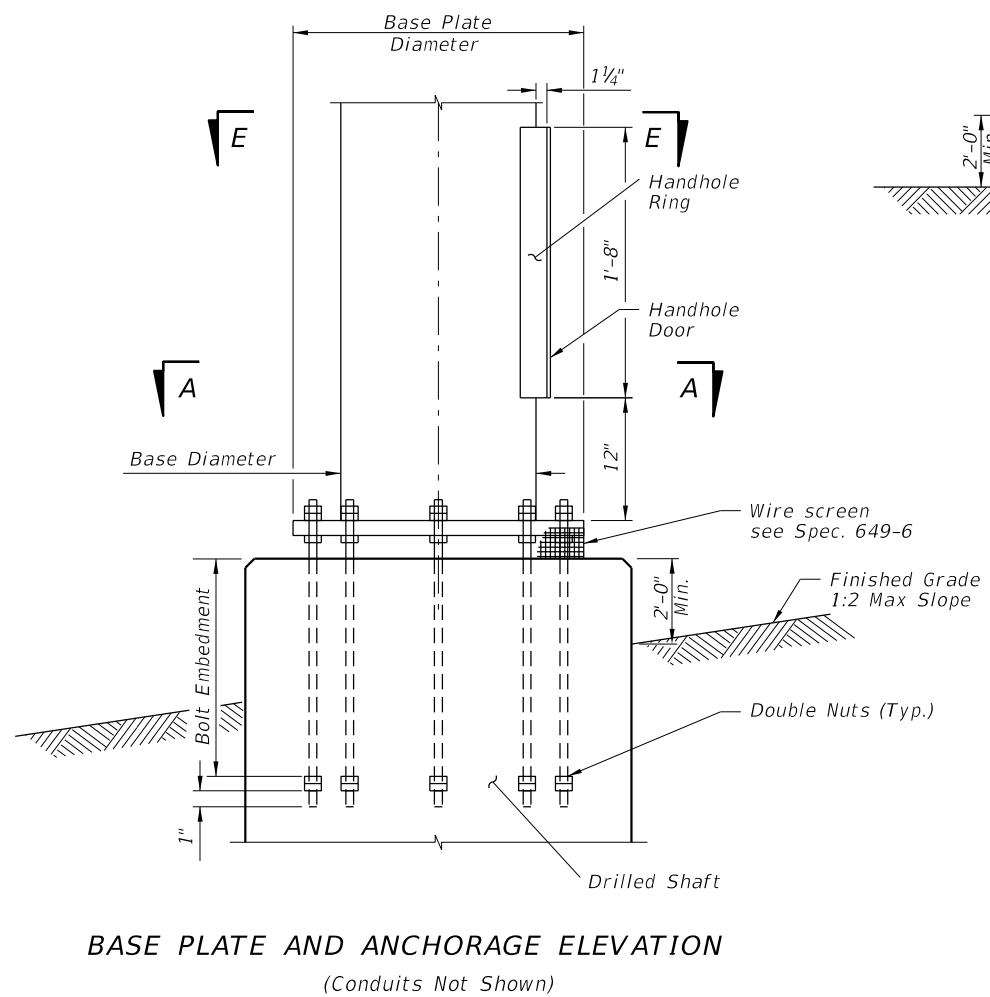
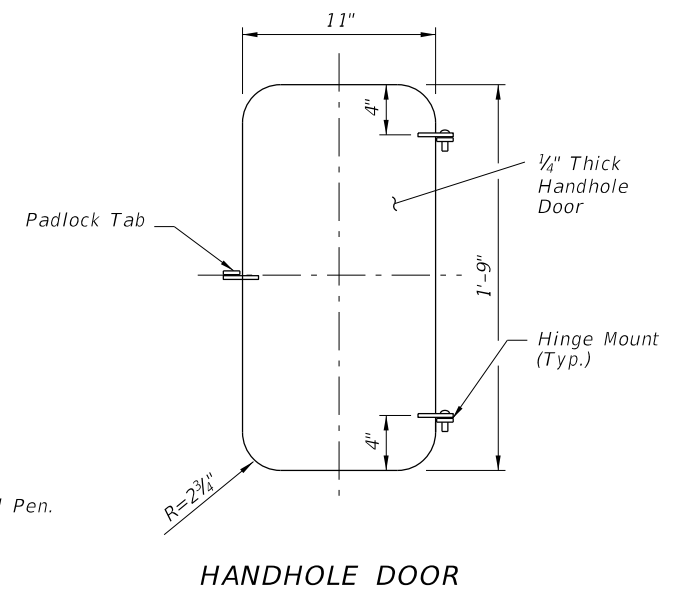
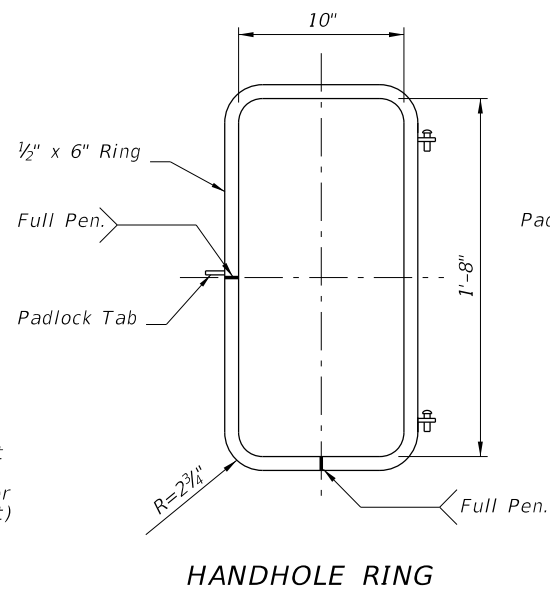
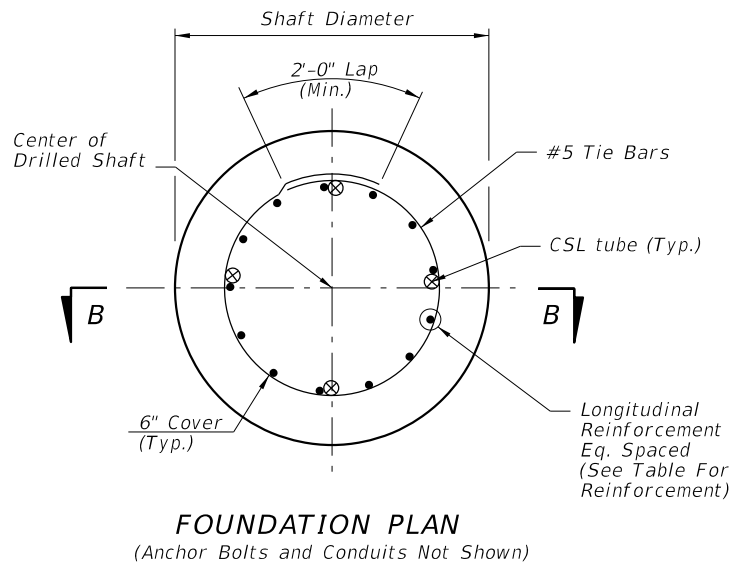
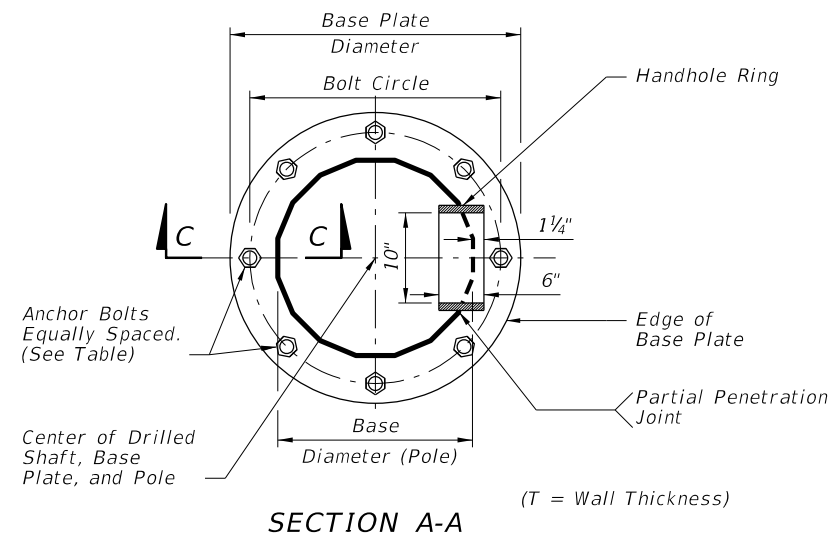

10/14/2016 10:54:54 AM

LAST REVISION 11/01/16	DESCRIPTION:
---------------------------	--------------

FDOT FY 2017-18 DESIGN STANDARDS

HIGH MAST LIGHTING

POLE FOUNDATION

INDEX NO. 17502	SHEET NO. 3 of 6
--------------------	---------------------

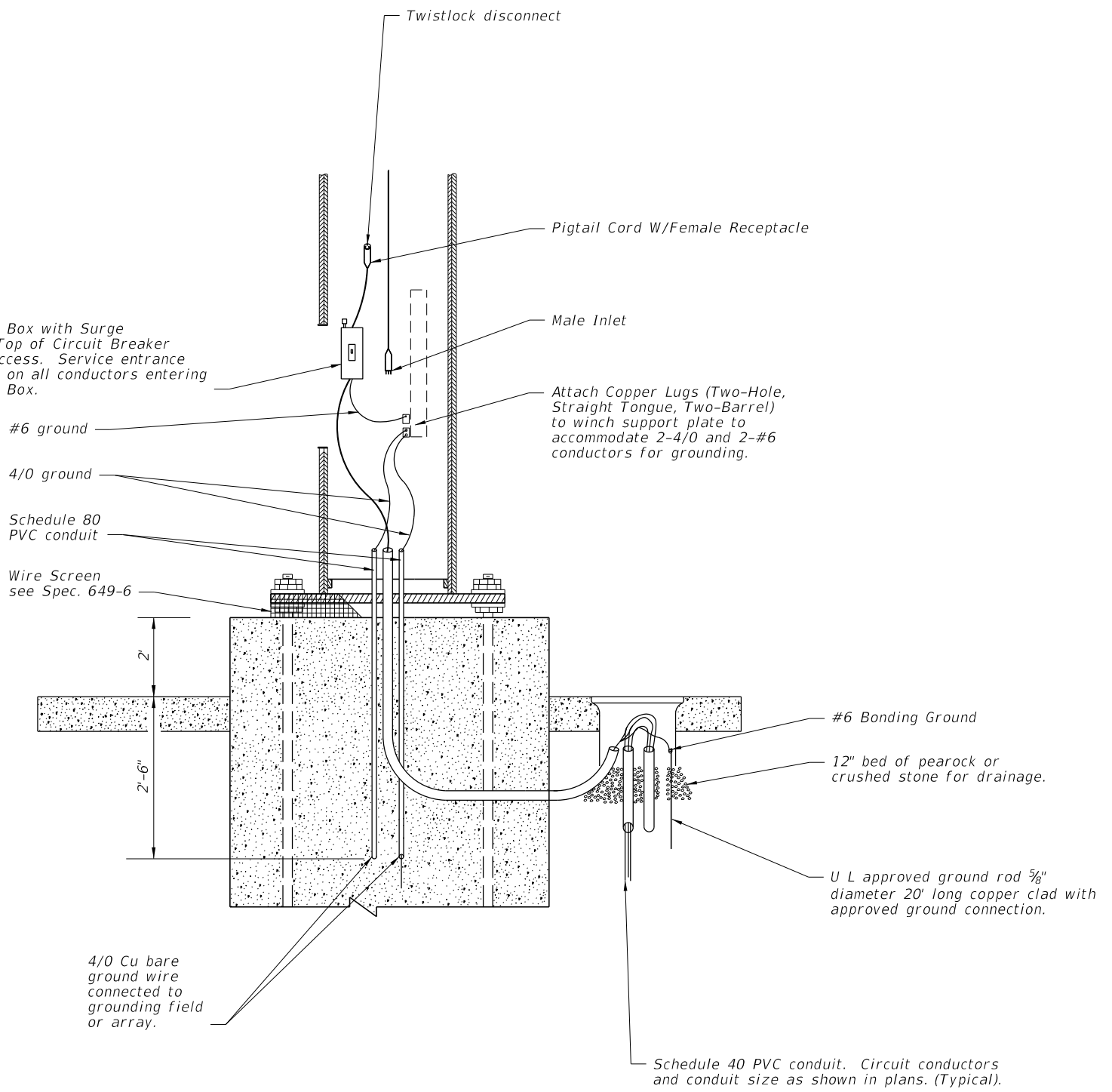
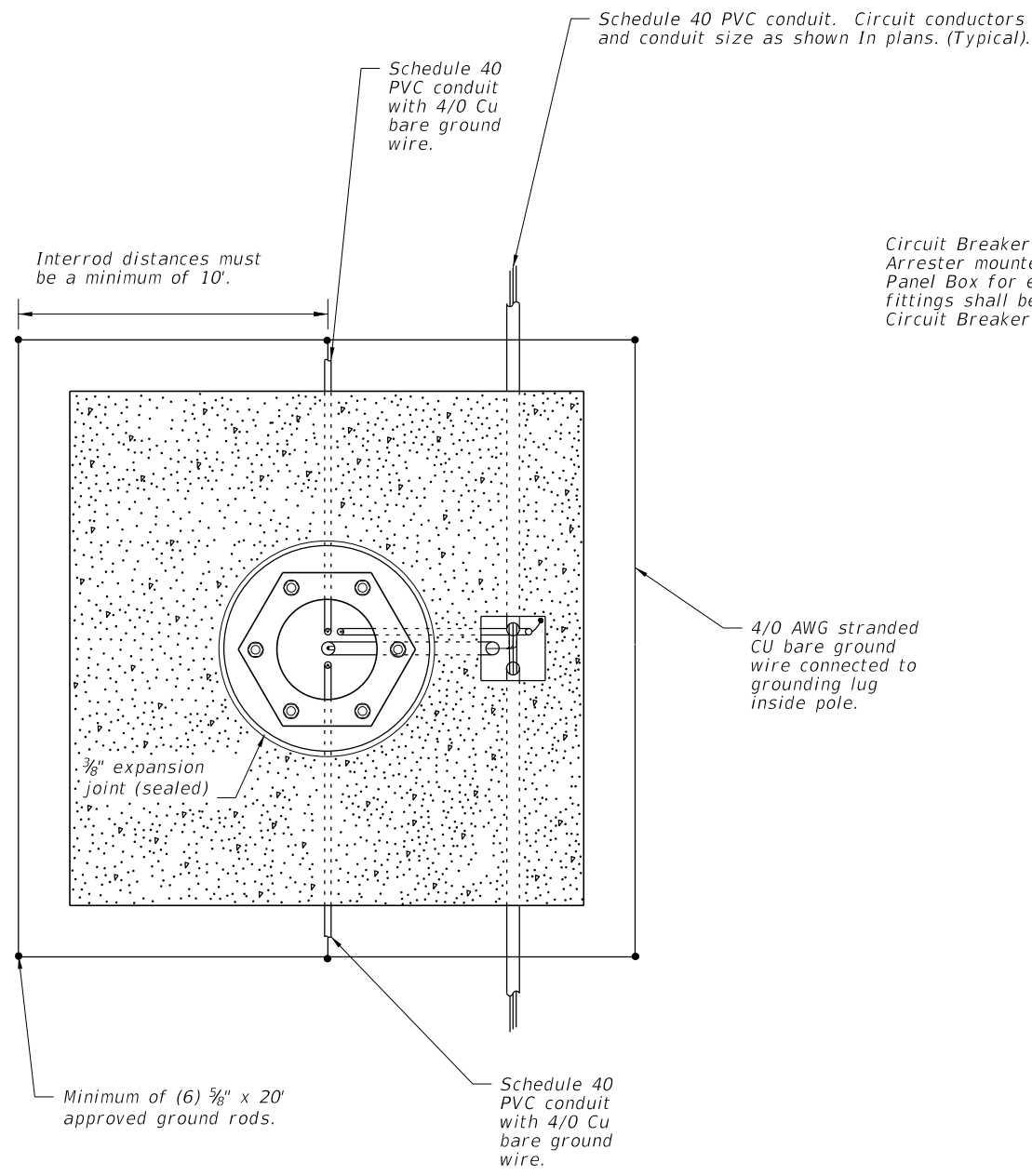

NOTES:

1. At all pull boxes and pole bases, ends of conduit shall be sealed in accordance with Section 630 of the Standard Specifications For Road And Bridge Construction.
2. Slabs to be placed around all Poles and Pull Boxes.
3. For Pull Boxes between Poles refer to Index 17500.

WIRING DETAILS

10/14/2016 10:54:57 AM

LAST REVISION 01/01/12	REVISION	DESCRIPTION:	 FY 2017-18 DESIGN STANDARDS	HIGH MAST LIGHTING	INDEX NO. 17502	SHEET NO. 4 of 6
---------------------------	----------	--------------	--	---------------------------	---------------------------	----------------------------

The contractor's attention is directed to those plan sheets detailing the mounting of luminaires at the pole top. Particular attention is directed to alignment of luminaire light distributions. Special attention must be exercised in the physical alignment of these luminaires to ensure that the approved photometric layout is physically produced at each lighting standard in the field. A marking shall be placed on the external face of the refractor to allow visual inspection of alignment. The marking shall correspond to the 0° axis of the refractor.

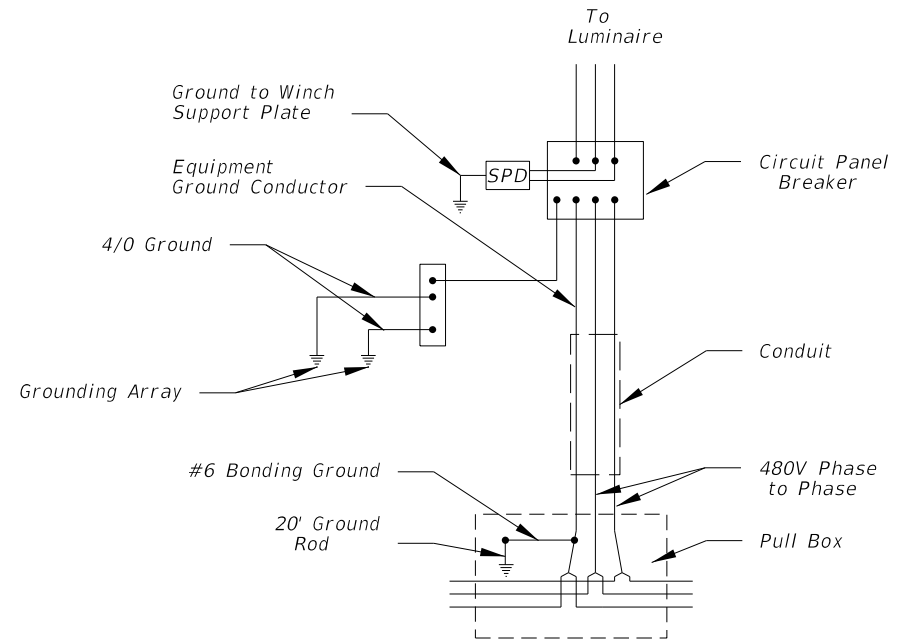
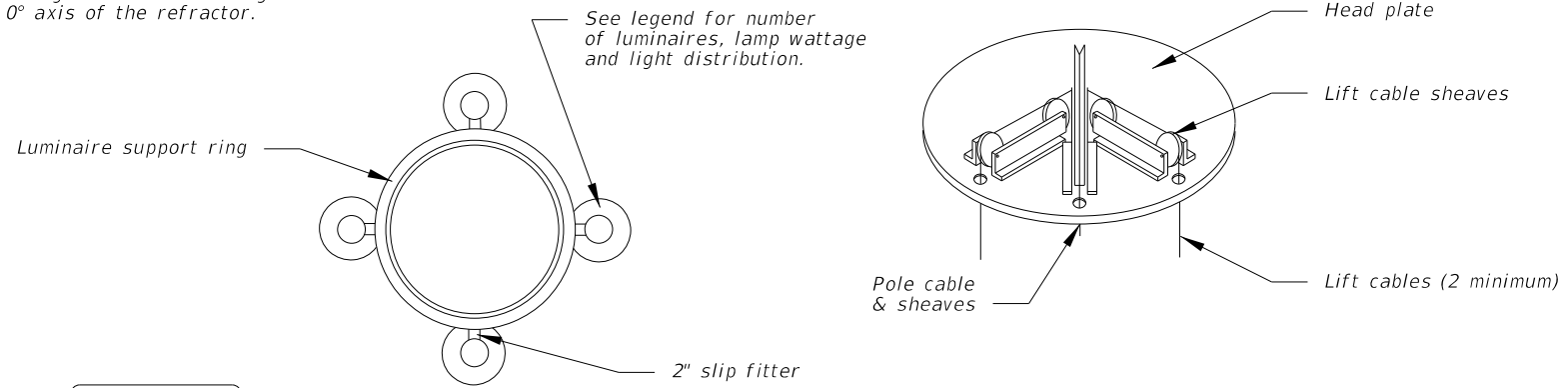

HIGH MAST POLE WIRING DIAGRAM

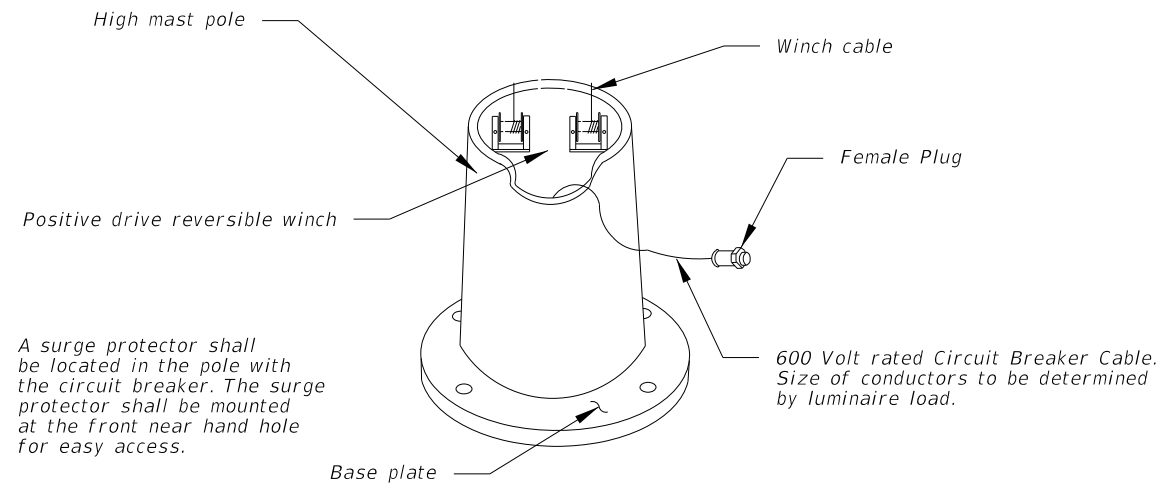
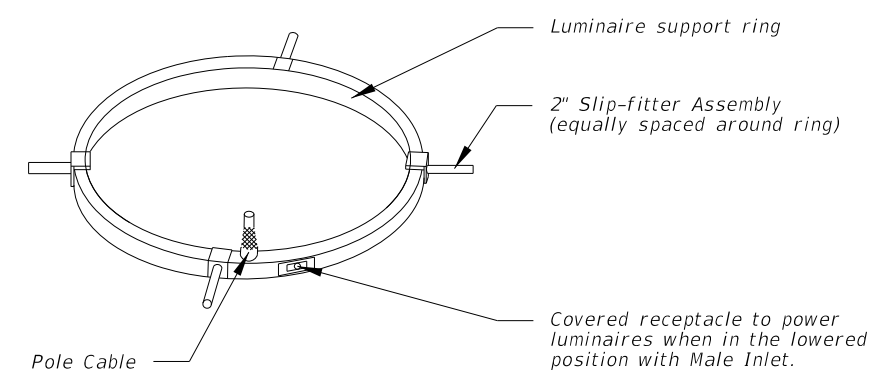
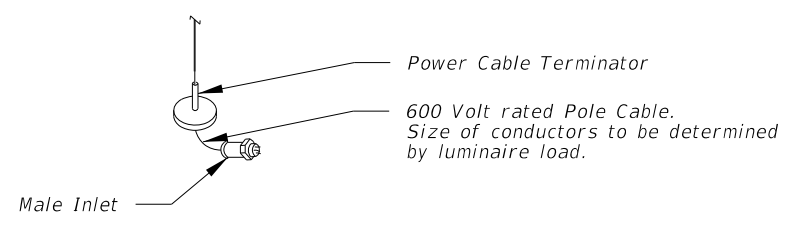
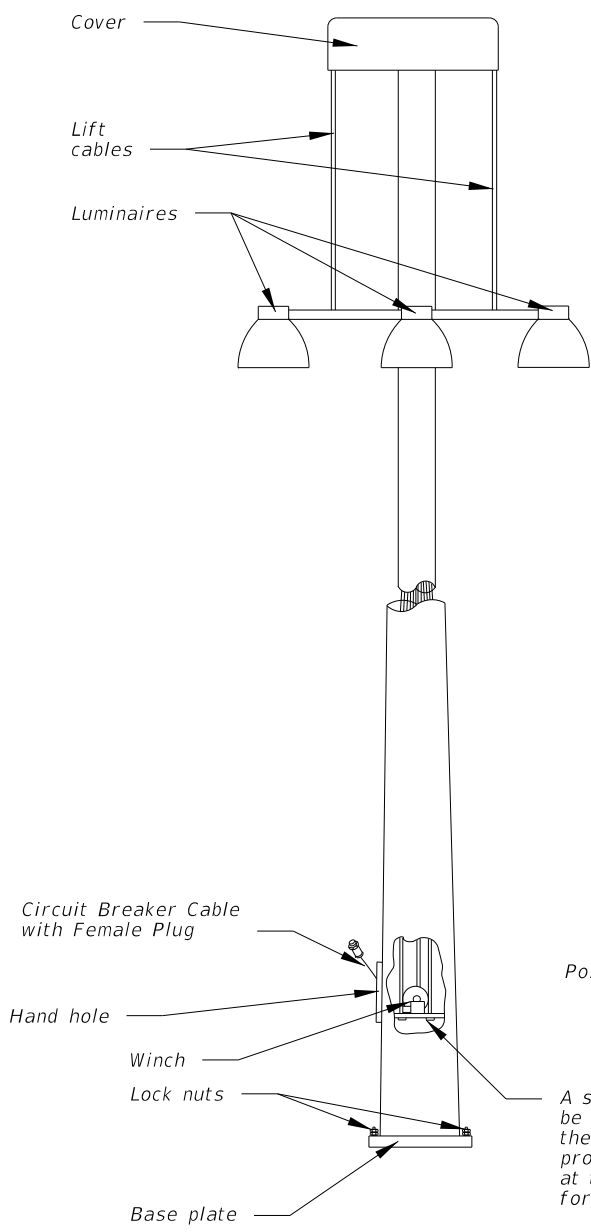

A surge protector shall be located in the pole with the circuit breaker. The surge protector shall be mounted at the front near hand hole for easy access.

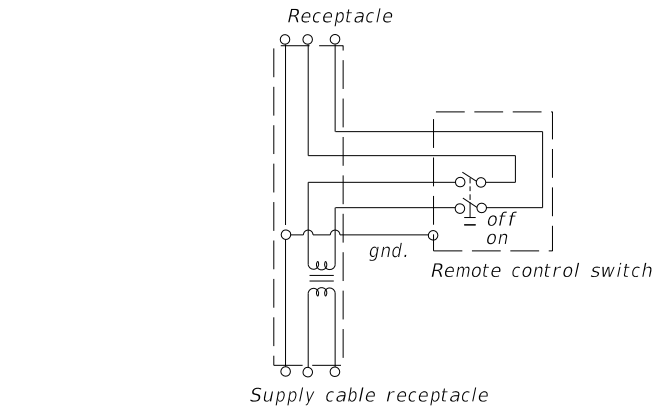
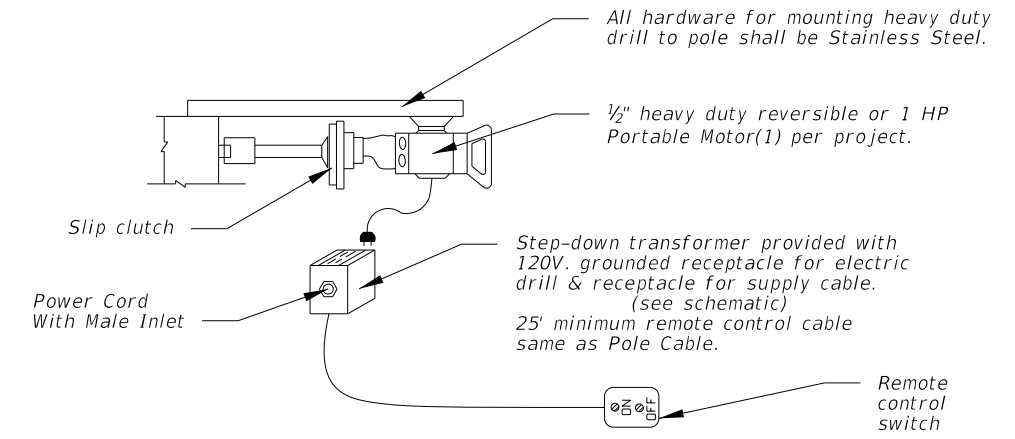

SCHEMATIC OF REMOTE AUXILIARY POWER UNIT

LOWERING DETAILS

10/14/2016 10:54:59 AM

LAST REVISION 01/01/12	DESCRIPTION:		FY 2017-18 DESIGN STANDARDS	HIGH MAST LIGHTING	INDEX NO. 17502	SHEET NO. 5 of 6
REVISION						

NOTES:

1. Use compacted select material in accordance with Index 505.
2. Concrete shall be Class NS with a minimum strength at 28 days of $f'c=2.5$ ksi.
3. Outside edge of slab shall be cast against formwork.
4. The pull box shown is 13" x 24"; others approved under Section 635 of the Standard Specifications may be used.
5. Slabs to be placed around all Poles and Pull Boxes. In urban areas or where space is limited slab dimensions may be adjusted as shown in the plans.
6. Concrete for slabs around poles and pull boxes shall be included in the price of pole or pull box.
7. The expansion joint shall consist of $\frac{1}{2}$ " of closed-cell polyethelene foam expansion material. The top $\frac{1}{2}$ " of expansion material shall be removed after pouring the slab and sealed with an APL approved Type A sealant meeting the requirements of Section 932.

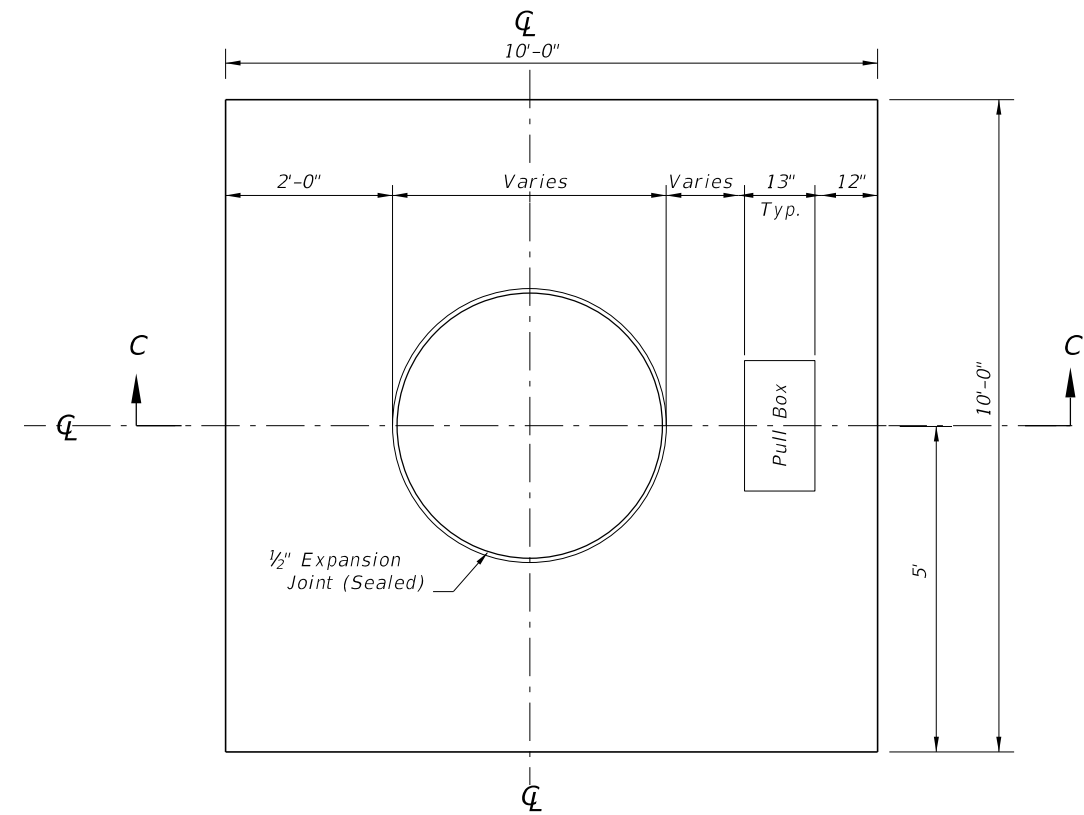

SLAB DIMENSIONS

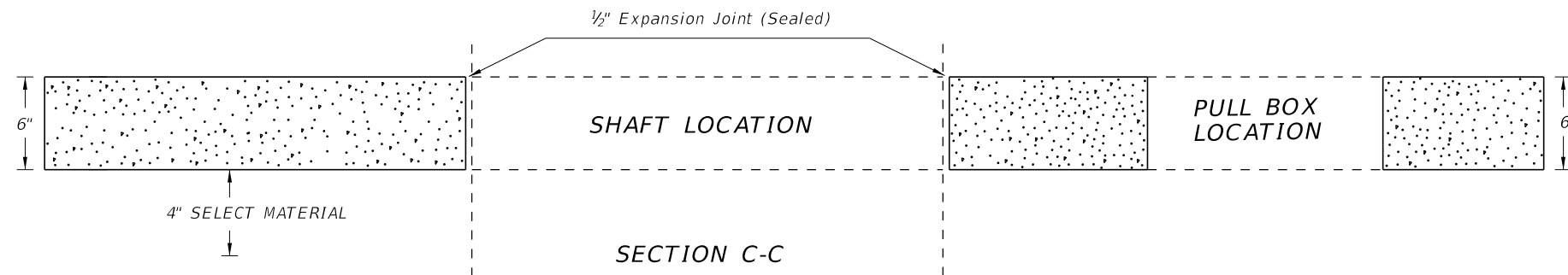

SLAB DETAILS

10/14/2016 10:55:01 AM

LAST REVISION	07/01/14	REVISION	DESCRIPTION:
---------------	----------	----------	--------------