

TOP VIEW

Clips Permitted On 3'-0" Frame

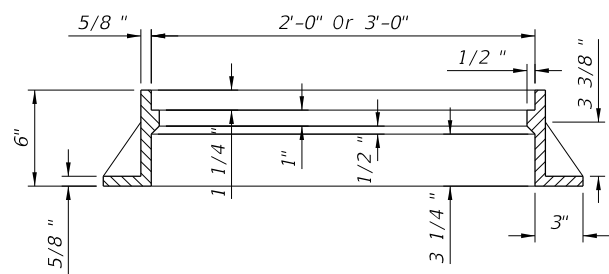

SECTION  
For Manholes  
**TYPE I**

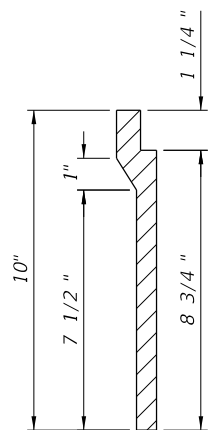

WALL SECTION

For Curb Inlets Types 1, 2, 3, & 4

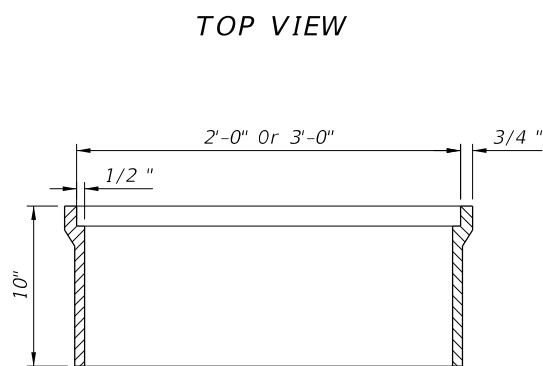

TOP VIEW

**TYPE II**

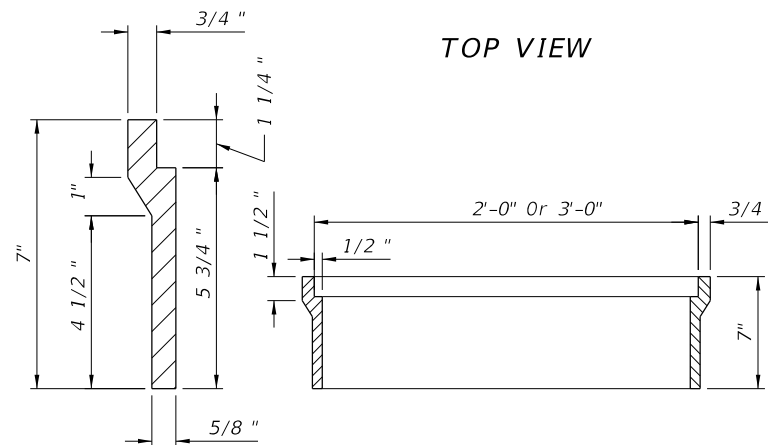

WALL SECTION

For Curb Inlets Types 7 & 8

**TYPE III**

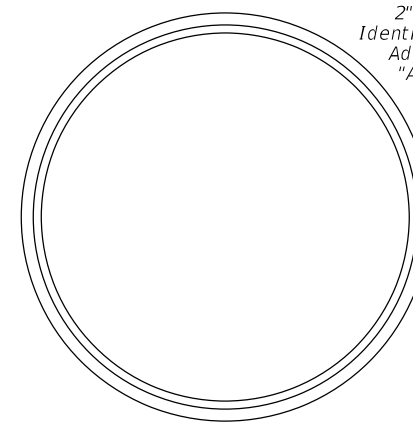

TOP VIEW

2" Raised Or Depressed Identification Letter Type I Adjustable Shall Include "ADJUSTABLE" On Cover

Pick-Up Hole

FDOT  
STORM  
SEWER

Raised Or Depressed Logo

Nonskid Surface

TOP VIEW

2" Raised Or Depressed Identification Letter

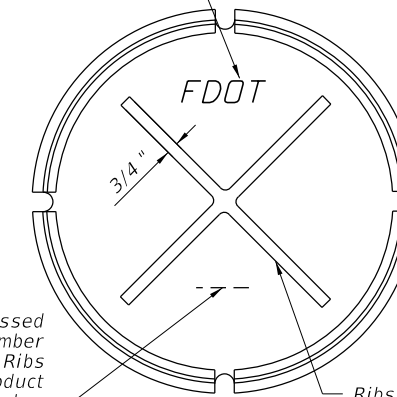

BOTTOM VIEW

2" Raised Or Depressed Identification Number Covers With And Without Ribs Shall Bear The Same Product Identification Number

Ribs (Optional)

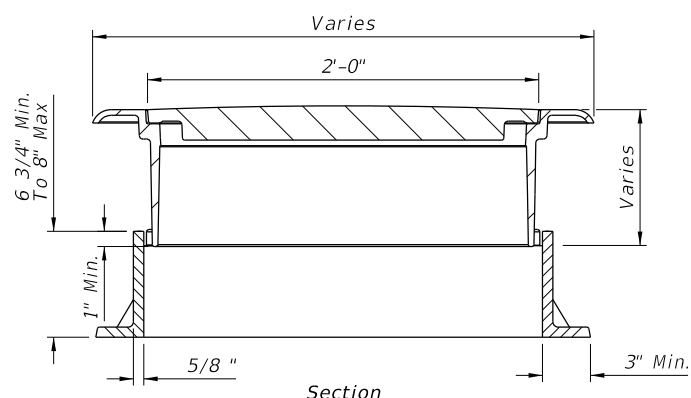

Section

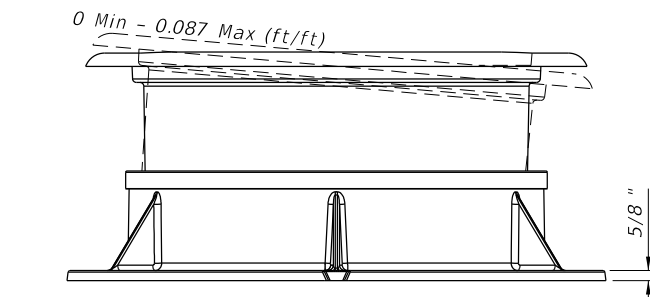

Front View  
**TYPE I ADJUSTABLE**

WEIGHT OF CASTINGS (lb)						
Frame Type	2' OPENING		3' OPENING			
	Frame	Cover (Std.)	Frame	2-Piece Cover		
				Inside	Outside	Total
I *	155	190	220	190	220	410
II	145	190	255	190	220	410
III	90	190	180	190	220	410

\* Includes Type I Adjustable

NOTES (FRAMES, AND COVER)

1. The standard cover is to be used for all frames Types I, II, III and the 2-piece cover, and is the replacement cover for all previous frames with 1 1/2" deep seats (traffic type). The 185 lb. cover (nontraffic type), 1984 Roadway and Traffic Design Standards Index No. 201, is the replacement cover for existing frames with 1/2" deep seats. Installation of frame with 1/2" deep seats is not permitted.

2. Use the 2'-0" cover, unless the 2-piece cover is called for in the plans, except at inlets and manholes with sump bottoms use the 2-piece cover when the sump depth exceeds 2', unless otherwise noted.

DESIGNER NOTE:

Consider using the 2-piece cover where depths exceed 5' and manual entry may be required for cleaning. Clearly note the requirement for a 2-piece cover, on the Drainage Structure sheets in the plans.

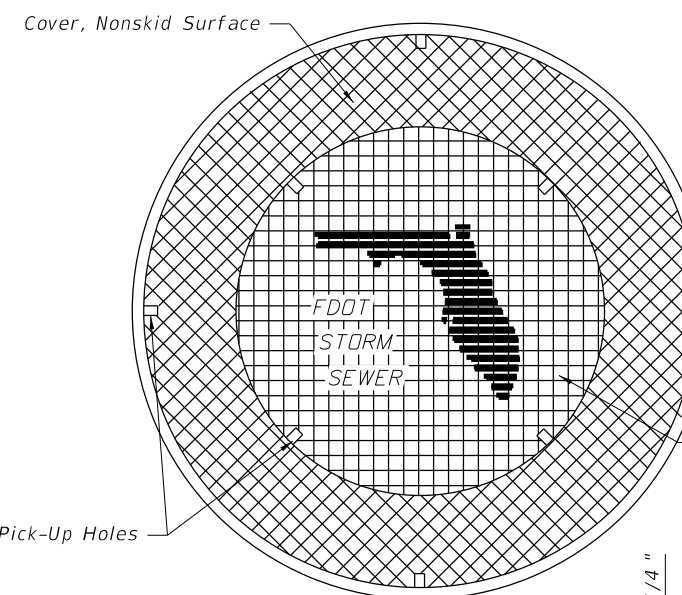

Pick-Up Holes

For Use With Types I, II And III Frames With 3'-0" Opening

**2-PIECE COVER**

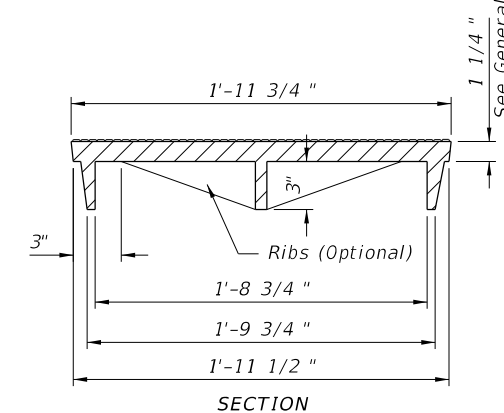

**COVER FOR ALL FRAMES**

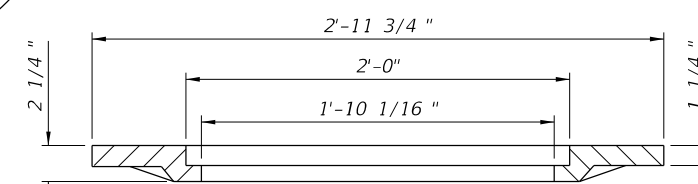

**2-PIECE COVER**

11/11/2016 8:32:00 AM

LAST REVISION  
01/01/12

DESCRIPTION:

**FDOT** FY 2017-18  
DESIGN STANDARDS

SUPPLEMENTARY DETAILS FOR MANHOLES & INLETS

INDEX NO.  
201

SHEET NO.  
1 of 5

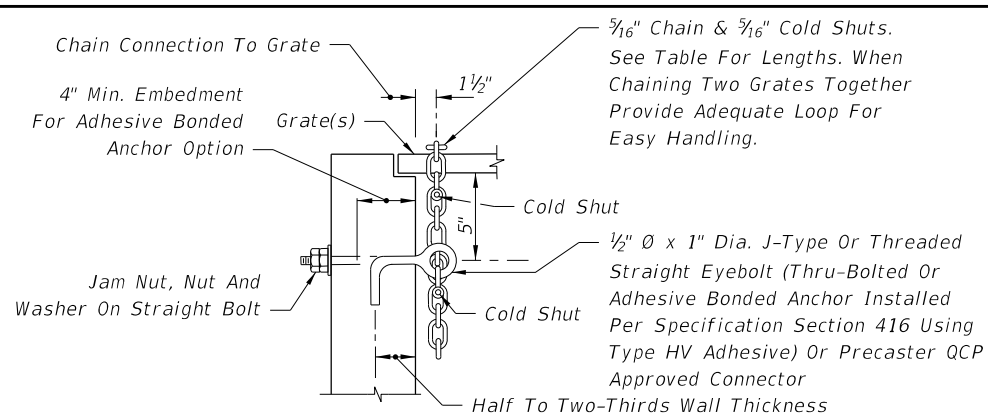

NOTE: When Alternate "G" grate is specified, the chain, bolt, nuts, washer and cold shuts shall be galvanized in accordance with Section 425 of the Standard Specifications.

Cost of eyebolt and chain to be included in the contract unit price for inlets.

EYEBOLT AND CHAIN REQUIREMENTS				
Index Number	Inlet Type	Eye-Bolts	Length Of Chain	Handling & Remarks
217	(MB) 1	1	4'-0"	Slide & Spin
	(MB) 2	1	4'-0"	Slide & Spin
	(MB) 3	2	2 @ 4'-0"	Slide & Spin
	(MB) 4	2	2 @ 4'-0"	Slide & Spin
	(MB) 5	2	2 @ 4'-0"	Slide & Spin
218	(BW)	1	3'-8"	Slide Or Slide & Spin
219	(BW, RGD)	1	4'-0"	Slide & Spin
220	S	1	4'-0"	Slide & Spin
221	V	1	4'-0"	Slide & Spin
230	A	1	3'-0"	Slide
231	B	1	5'-0"	Slide & Spin
232	C	1	2'-6"	Slide & Spin
	D	1	2'-6"	Slide & Spin
	E	2	2 @ 2'-6"	Slide & Spin
	H	2	2 @ 2'-6"	Flip Ctr. Grate and Slide & Spin Single Free Grate
233	F	1	3'-6"	Flip Or Slide & Spin
	G	1	6'-0"	Slide
			2'-0"	Lifting Loop
234	J	1	4'-0"	Slide & Spin

**EYEBOLT AND CHAIN FOR LOCKING GRATES TO INLETS**

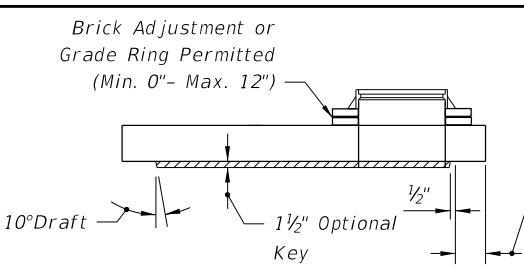
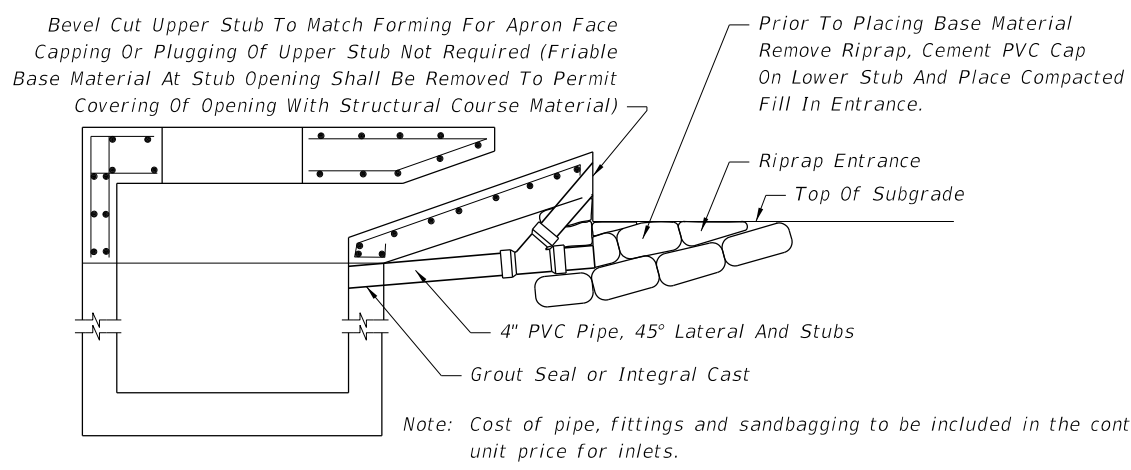

**SECTION TYPE 7**  
Note: See Slab Designs Index No. 200.

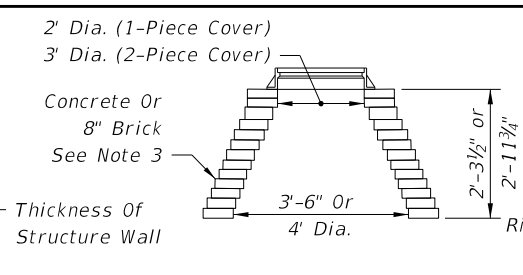

**BRICK OR CONCRETE PRECAST CONCENTRIC CONE TYPE 8 MANHOLE TOPS**

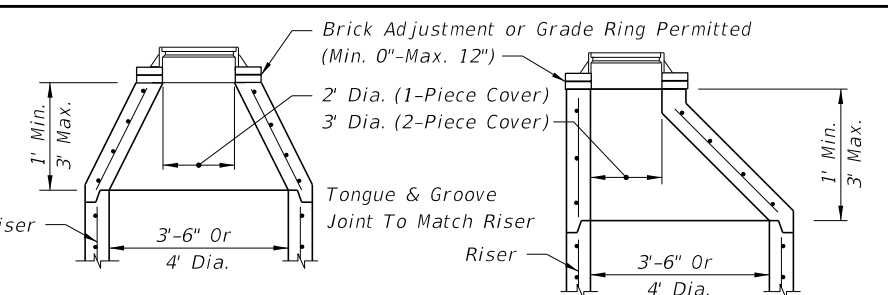

**PRECAST ECCENTRIC CONE TYPE 8**

**NOTES (TOPS)**

- Manhole top Type 7 slabs shall be of Class II concrete. Concrete as specified in ASTM C478 may be used for precast units; see General Note No. 3.
- Manhole top Type 7 slabs may be of cast-in-place or precast construction. The optional key is for precast tops and in lieu of dowels. Frame and slab openings are to be omitted when top is used over a junction box.
- Manhole top Type 8 may be of cast-in-place or precast concrete construction or brick construction. For concrete construction, the concrete and steel reinforcement shall be the same as the supporting wall unit. An eccentric cone may be used.
- Manhole tops shall be secured to structures by optional construction joints as shown on Sheet 3.
- Frames can be adjusted a maximum 12" height with brick or precast ASTM C478 grade rings.
- Substitution of manhole top Type 8 for manhole top Type 7 is allowed provided that minimum dimensions shown above are not reduced.
- Substitution of Manhole top Type 7 for Type 8 is allowed if the minimum thickness (h) above pipe opening cannot be maintained with manhole top Type 8.

**DESIGN NOTES**

- Manhole top Type 8 should be specified in the plans when depths shown above can be maintained.

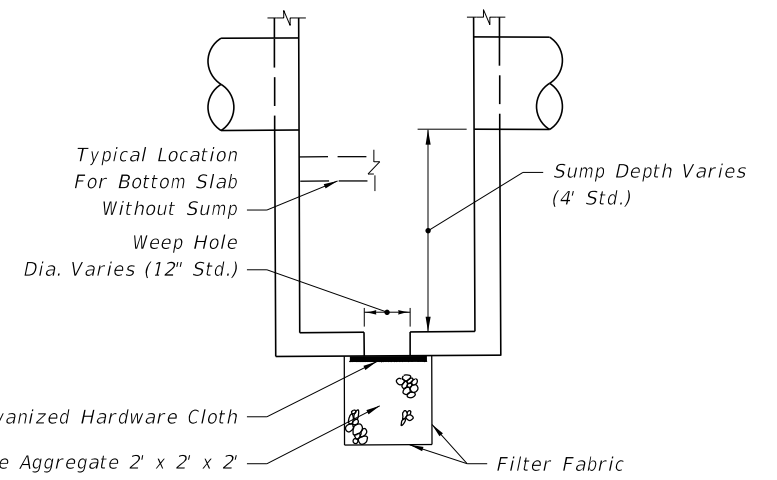

NOTE: Sump bottom appropriate for all manhole and inlet types. Sumps are to be constructed in inlet and manholes connected to French Drains unless excluded in the plans. At other locations, sump is to be constructed only where called for in the plans. Weep holes to be constructed in sump bottom only where called for in the plans. Cost of sump bottom and weep hole to be included in the contract unit price for inlet or manhole.

**SUMP BOTTOM**

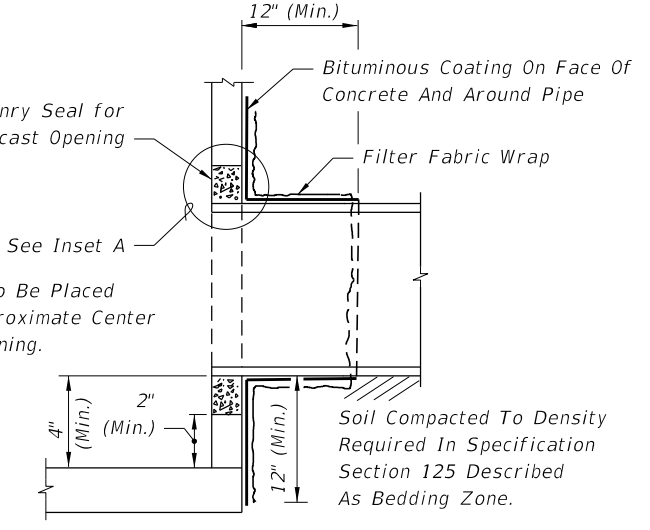
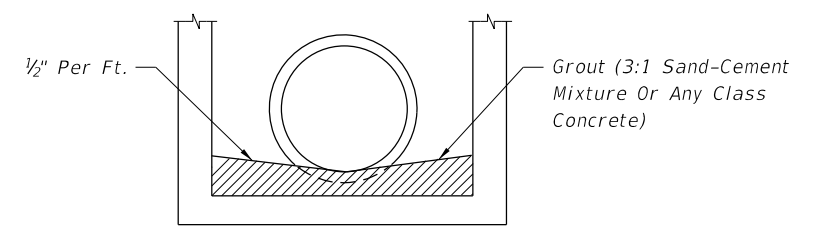

**FILTER FABRIC WRAP ON GROUTED PIPE TO STRUCTURE JOINT**

**FOR ALL STRUCTURES UNLESS EXCLUDED BY SPECIAL DETAIL ALL PIPE TYPES DRAINAGE STRUCTURE INVERT**

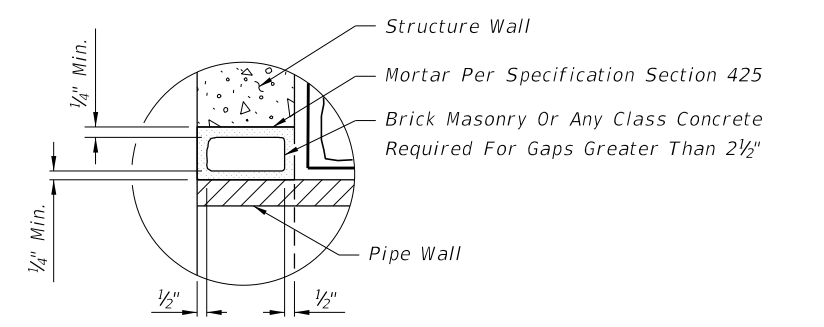

**INSET A**

10/11/2016 10:15:51 AM

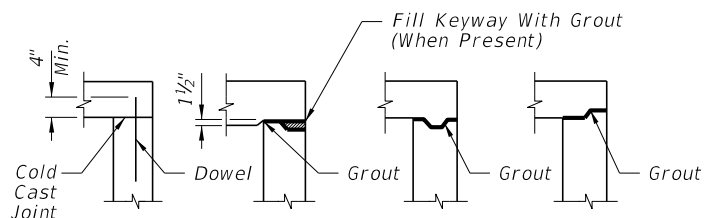

TOP SLABS TO WALLS

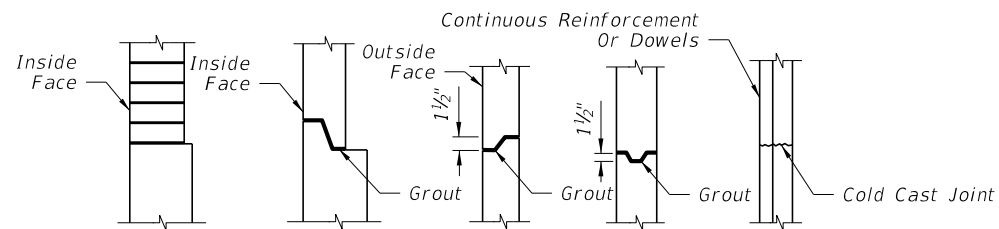

WALL JOINTS

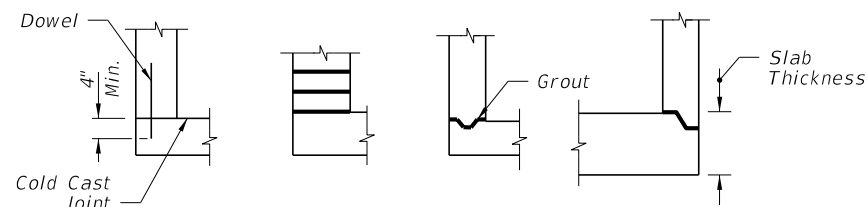

BOTTOM SLABS TO WALLS

1. One or more types of joints may be used in a single structure, except brick wall structure. Brick wall construction is permitted on circular units only.
2. All grouted joints are to have a maximum thickness of 1".
3. Keyways are to be a minimum of 1 1/2" deep.
4. Joint dowels are to be #4 bars, 12" long with a minimum of 6 bars per joint approximately evenly spaced for circular structures or at maximum 12" spacing for rectangular structures. Bars may be either Adhesive Bonded Dowels in accordance with Specification Section 416, or placed approximately 6" into fresh concrete leaving the remainder to extend into the secondary cast. Welded wire reinforcement may be substituted for the dowel bar in accordance with the equivalent steel area table on Sheet 4.
5. Minimum cover on dowel reinforcing bars is 2" to outside face of structure.
6. Joints between wall segments and between wall segments and top or bottom slabs may be sealed either by preformed plastic gasket material using the procedures given in Section 430 of the Specifications or by non-shrink grout, in accordance with Section 934 of the Specifications.
7. Insert products approved by the Engineer may be used in lieu of dowel embedment.

OPTIONAL CONSTRUCTION JOINTS

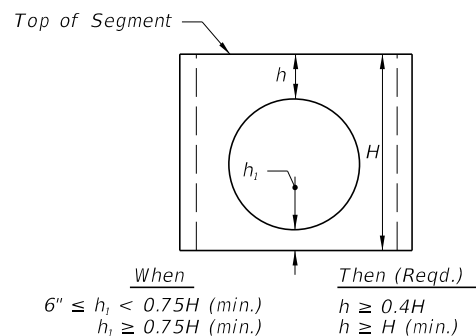

SEPARATE RISER SEGMENTS WITH CONSTRUCTION JOINTS OTHER THAN DOWEL OPTION

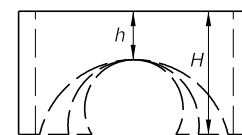

Segments may be inverted. Opening for pipe shall be the pipe OD plus 6" (± 2" tolerance). If h can not be attained, then a top or bottom slab must be attached to the segment as shown below.

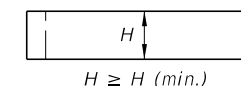

Minimum Value For H	
H (min.)	Box Or Riser Diameter
1'-0"	3'-6" & 4'-0"
1'-6"	5'-0" & 6'-0"
2'-0"	>6'-0"

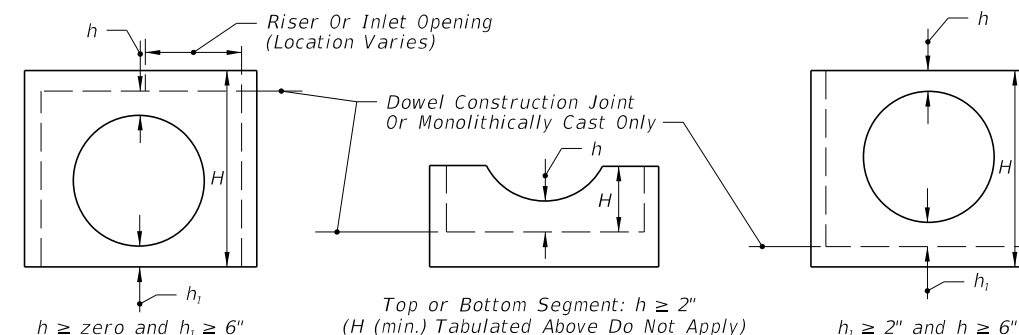

SEGMENTS FOR SLAB TO WALL DOWEL CONSTRUCTION JOINTS OR MONOLITHICALLY CAST SEGMENTS

NOTE: h may be less than 6" when approved by the Engineer, but not for inlet segments at finish grade elevation.

COMPARATIVE SIDE VIEWS

MINIMUM DIMENSIONS FOR BOX AND RISER SEGMENTS

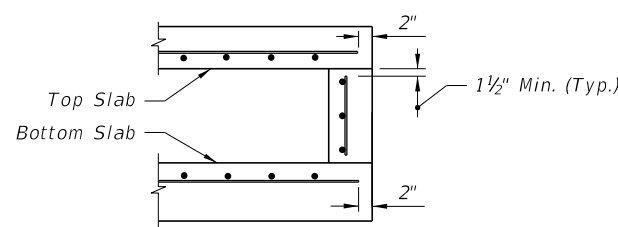

(NOTE: NOT APPLICABLE AROUND MANHOLE AND RISER OPENINGS)

REBAR STRAIGHT END EMBEDMENT FOR TOP AND BOTTOM SLABS

Option 1) Lap Splice: At Quarter Point (30 Bar Diameters Or Vertical Wire Spacing Plus 2" For WWR)  
 Option 2) Lap Splice: Standard 90° Hooks At Corners (8" For #4's, 10" For #5's, 12" for #6's)

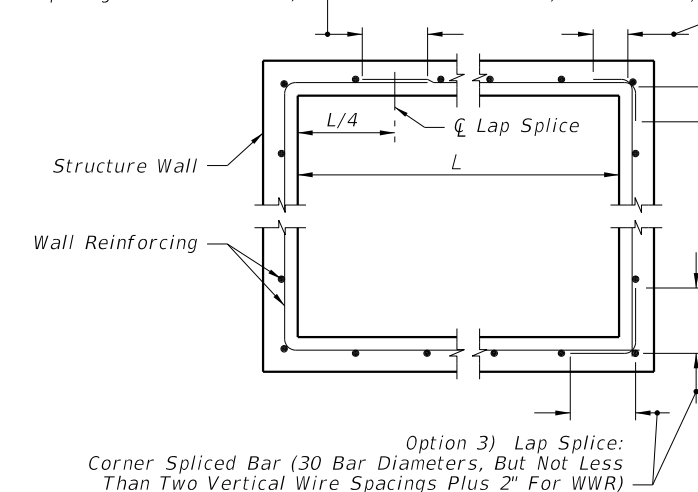

Option 3) Lap Splice: Corner Spliced Bar (30 Bar Diameters, But Not Less Than Two Vertical Wire Spacing Plus 2" For WWR)

WALL REINFORCING SPLICE DETAILS

10/11/2016 10:15:54 AM

LAST REVISION 07/01/15	DESCRIPTION:	FY 2017-18 DESIGN STANDARDS	SUPPLEMENTARY DETAILS FOR MANHOLES & INLETS	INDEX NO. 201	SHEET NO. 3 of 5
---------------------------	--------------	--------------------------------	---	------------------	---------------------

EXAMPLE TABLE OF EQUIVALENT STEEL AREA

SCHEDULE	GRADE 60 REINFORCING BAR		EQUIVALENT GRADE 40 REINFORCING BAR		EQUIVALENT 65 KSI SMOOTH WELDED WIRE REINFORCEMENT		EQUIVALENT 70 KSI DEFORMED WELDED WIRE REINFORCEMENT	
	Bar Size & Spacing	Steel Area (in <sup>2</sup> /ft)	Bar Size & Spacing	Min. Steel Area (in <sup>2</sup> /ft)	Style Designation	Min. Steel Area (in <sup>2</sup> /ft)	Style Designation	Min. Steel Area (in <sup>2</sup> /ft)
A	#3 @ 6 1/2" Ctrs. #4 @ 12" Ctrs.	0.20	#3 @ 4 1/2" Ctrs. #4 @ 8" Ctrs. #5 @ 12" Ctrs.	0.30	3"x3"-W4.6xW4.6 4"x4"-W6.2xW6.2 6"x6"-W9.2xW9.2	0.1846	3"x3"-D4.3xD4.3 4"x4"-D5.7xD5.7 6"x6"-D8.6xD8.6	0.1714
B	#3 @ 5 1/2" Ctrs. #4 @ 10" Ctrs.	0.24	#3 @ 3 1/2" Ctrs. #4 @ 6 1/2" Ctrs. #5 @ 10" Ctrs.	0.36	3"x3"-W5.5xW5.5 4"x4"-W7.4xW7.4 6"x6"-W11.1xW11.1	0.2215	3"x3"-D5.1xD5.1 4"x4"-D6.9xD6.9 6"x6"-D10.3xD10.3	0.2057
Special 1	#3 @ 5" Ctrs.. #4 @ 9" Ctrs.	0.267	#3 @ 3" Ctrs. #4 @ 6" Ctrs. #5 @ 9" Ctrs.	0.40	3"x3"-W6.2xW6.2 4"x4"-W8.2xW8.2 6"x6"-W12.3xW12.3	0.2465	3"x3"-D5.7xD5.7 4"x4"-D7.6xD7.6 6"x6"-D11.4xD11.4	0.2289
C	#3 @ 3 1/2" Ctrs. #4 @ 6 1/2" Ctrs. #5 @ 10" Ctrs.	0.37	#4 @ 4" Ctrs. #5 @ 6 1/2" Ctrs. #6 @ 9 1/2" Ctrs.	0.555	3"x3"-W8.5xW8.5 4"x4"-W11.4xW11.4 6"x6"-W17.1xW17.1	0.3415	3"x3"-D7.9xD7.9 4"x4"-D10.6xD10.6 6"x6"-D15.9xD15.9	0.3171
D	#4 @ 4 1/2" Ctrs. #5 @ 7" Ctrs. #6 @ 10" Ctrs.	0.53	#4 @ 3" Ctrs. #5 @ 4 1/2" Ctrs. #6 @ 6 1/2" Ctrs.	0.795	3"x3"-W12.2xW12.2 4"x4"-W16.3xW16.3 6"x6"-W24.5xW24.5	0.4892	3"x3"-D11.4xD11.4 4"x4"-D15.1xD15.1 6"x6"-D22.7xD22.7	0.4543
E	#4 @ 3" Ctrs. #5 @ 5" Ctrs. #6 @ 7" Ctrs.	0.73	#5 @ 3 1/2" Ctrs. #6 @ 4 1/2" Ctrs. #7 @ 6 1/2" Ctrs.	1.095	3"x3"-W16.8xW16.8 4"x4"-W22.5xW22.5 6"x6"-W33.7xW33.7	0.6738	3"x3"-D15.6xD15.6 4"x4"-D20.9xD20.9 6"x6"-D31.3xD31.3	0.6257
F	#5 @ 3 1/2" Ctrs. #6 @ 5" Ctrs. #7 @ 7" Ctrs.	1.06	#6 @ 3" Ctrs. #7 @ 4 1/2" Ctrs. #8 @ 6" Ctrs.	1.59	3"x3"-W24.5xW24.5 4"x4"-W32.6xW32.6 6"x6"-W48.9xW48.9	0.9785	3"x3"-D22.7xD22.7 4"x4"-D30.3xD30.3 6"x6"-D45.4xD45.4	0.9086
Special 2	#5 @ 3" Ctrs. #6 @ 4" Ctrs. #7 @ 5 1/2" Ctrs.	1.24	#7 @ 4" Ctrs. #8 @ 5" Ctrs.	1.86	3"x3"-W28.6xW28.6 4"x4"-W38.2xW38.2 6"x6"-W57.2xW57.2	1.1446	3"x3"-D26.6xD26.6 4"x4"-D35.4xD35.4 6"x6"-D53.1xD53.1	1.0629
G	#6 @ 3 1/2" Ctrs. #7 @ 5" Ctrs.	1.46	#7 @ 3" Ctrs. #8 @ 4" Ctrs.	2.19	3"x3"-W33.7xW33.7 4"x4"-W44.9xW44.9	1.3477	3"x3"-D31.3xD31.3 4"x4"-D41.7xD41.7	1.2514

NOTES FOR PRECAST OPTIONS AND EQUIVALENT REINFORCEMENT SUBSTITUTION

- Details for optional precast inlet construction up to depths of 15' are shown on the inlet indexes.
- When precast units are used in conjunction with Alt. "B" Structure Bottoms, Index No. 200, the interior dimensions of an Alt. "B" Bottom can be adjusted to reflect these inlet interior dimensions.
- Concrete which meets the requirements of ASTM C478 or Class IV must be used for precast structures constructed with 6" wall or slab thickness.
- Reinforcement can be either deformed bar reinforcement or welded wire reinforcement. Bar reinforcement other than 60 ksi may be used, however only two grades are recognized; Grade 40 and Grade 60. Smooth welded wire reinforcement, will be recognized as having a design strength of 65 ksi and deformed welded wire reinforcement will be recognized as having a design strength of 70 ksi. The area of reinforcement required may be adjusted in accordance with the Equivalent Steel Area Table provided. For bars and spacings not given, the steel area required can be determined by the following equations:

$$\text{Grade 40 Steel Area} = A_{s40} = \frac{60}{40} \times A_{s60}$$

$$\text{Smooth Welded Wire Reinforcement Steel Area} = A_{s65} = \frac{60}{65} \times A_{s60}$$

$$\text{Deformed Welded Wire Reinforcement Steel Area} = A_{s70} = \frac{60}{70} \times A_{s60}$$

When a reduced area of reinforcement is provided, any maximum bar spacing shown must also be reduced as determined by the following equations, unless otherwise shown:

$$\begin{aligned} \text{Max. Grade 40 Bar Spacing} &= \text{Grade 60 Bar Spacing} \\ \text{Max. Smooth Welded Wire Spacing} &= \text{Grade 60 Bar Spacing} \times 0.86 \\ \text{Max. Deformed Welded Wire Spacing} &= \text{Grade 60 Bar Spacing} \times 0.74 \end{aligned}$$

When an increased area of reinforcing is provided, then the maximum bar spacing may be increased by the squared ratio of increased steel area, but not to exceed 12":

$$\text{Max. Bar Spacing Provided} \leq \text{Max. Bar Spacing Required} \times \left( \frac{\text{Steel Area Provided}}{\text{Min. Steel Area Required}} \right)^2$$

In no case will reinforcement with wires smaller than W3.1 or D4.0, or spacings greater than 8" be permitted. Bar reinforcement shall show the minimum yield designation grade mark or either the number 60 or one (1) grade mark line to be acceptable at the higher value. Maximum bar spacing shall not be greater than two (2) times the slab thickness with a maximum spacing of 12" or three (3) times the wall thickness, with a maximum spacing of 18" for vertical bars and 12" for horizontal bars. Wires smaller than W3.1 or D4.0 are permitted in the walls of ASTM C 478 round structure bottoms and round risers.

- Fiber-reinforced concrete may be substituted for conventional steel reinforcement in accordance with the Structures Design Guidelines. Shop drawings corresponding to an approved fiber-reinforced concrete mix design must be submitted for approval to the State Drainage Engineer.

GENERAL NOTES

- For square or rectangular precast drainage structures, using either deformed or smooth WWR meeting the requirements of Specification Section 931, WWR shall be continuous around the box and lapped in accordance with Option 1 or 3 as shown in the Wall Reinforcing Splice Details.
- Horizontal steel in the walls of rectangular structures shall be lap spliced in accordance with Option 1, 2 or 3 as shown in the Wall Reinforcing Splice Details.
- Welding of splices and laps is permitted. The requirements and restrictions placed on welding in AASHTO M259 shall apply.
- Rebar straight end embedment of peripheral reinforcement may be used in lieu of ACI standard hooks for top and bottom slabs except when hooks are specifically called for in the plans or standard drawings.
- Concrete as specified in ASTM C478, (4000 psi) may be used in lieu of Class II concrete in precast items manufactured in plants which meet the requirements in accordance with Specification Section 449.
- Precast opening for pipe shall be the pipe OD plus 6" (± 2" tolerance). Mortar used to seal the pipe into the opening will be of such a mix that shrinkage will not cause leakage into or out of the structure. Dry-pack mortar may be used in lieu of brick and mortar construction to seal openings less than 2 1/2" wide.
- For pay item purposes, the height used to determine if a drainage structure is greater than 10 feet shall be computed using:
  - the elevation of the top of the manhole lid,
  - the grate elevation or the theoretical gutter grade elevation of an inlet, or
  - the outside top elevation of a junction box less the flow line elevation of the lowest pipe or to top of sump floor.

10/25/2016 8:15:12 AM

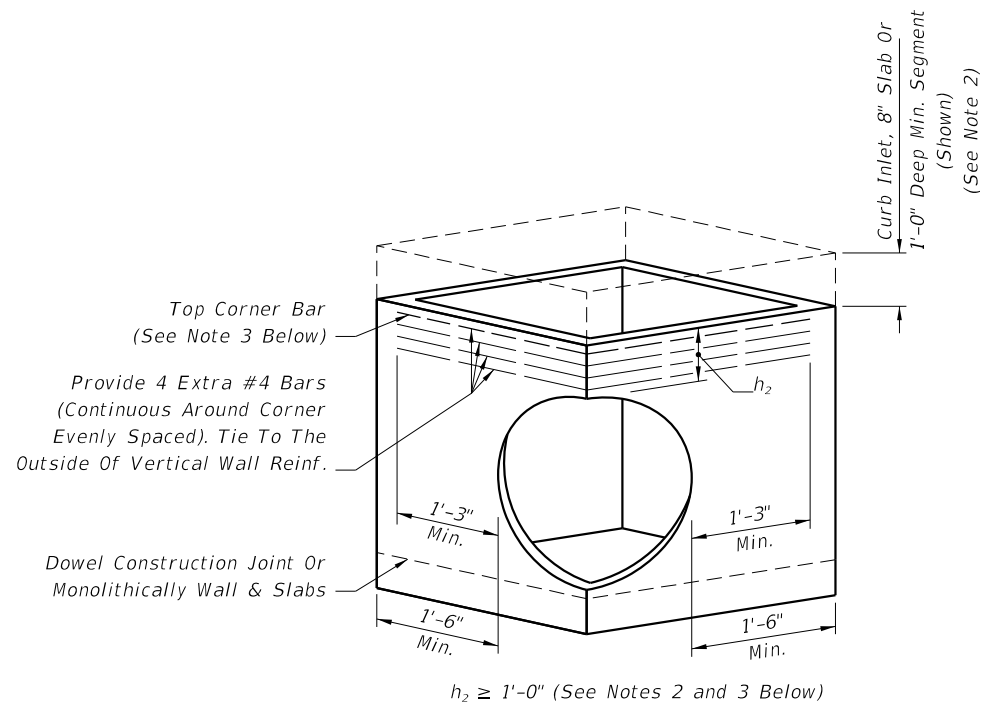

$h_2 \geq 1'-0"$  (See Notes 2 and 3 Below)

DESIGNER NOTE: Use only when round structures are not practical, engineer of record approval required.

**PICTORIAL VIEW**

- NOTE:
1. Submit Shop Drawings of corner openings for approval by the Engineer of Record.
  2.  $h_2$  may be less than 1'-0" when a minimum 1'-0" deep segment, 8" slab or curb inlet is provided above the corner opening.
  3. For inlet segments at finish grade elevation substitute a #8 Bar for the top corner bar when  $1'-0" \leq h_2 < 2'-0"$ .

**RECTANGULAR SEGMENT WITH PIPE OPENING AT CORNER**

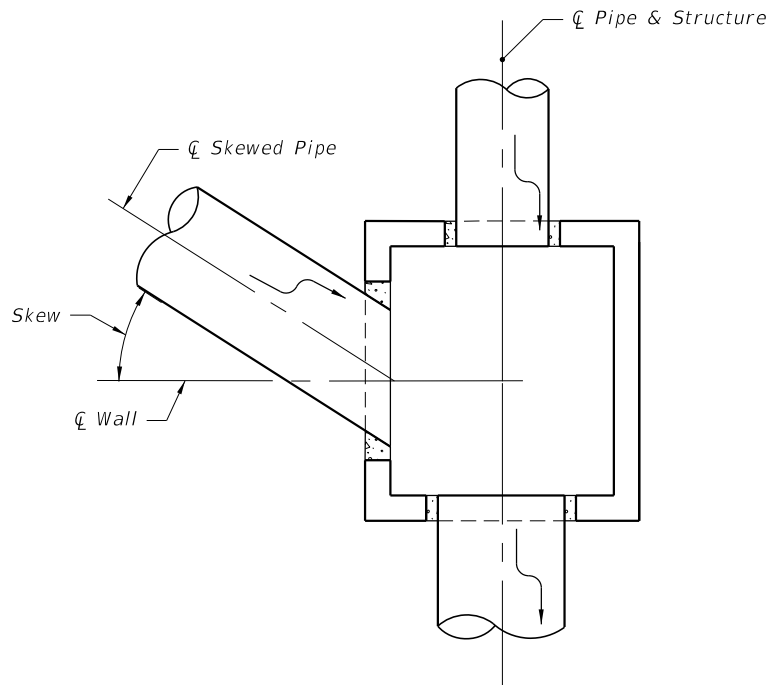

**PLAN VIEW FOR SKEWS  $\leq 45^\circ$   
(Not Centered)**

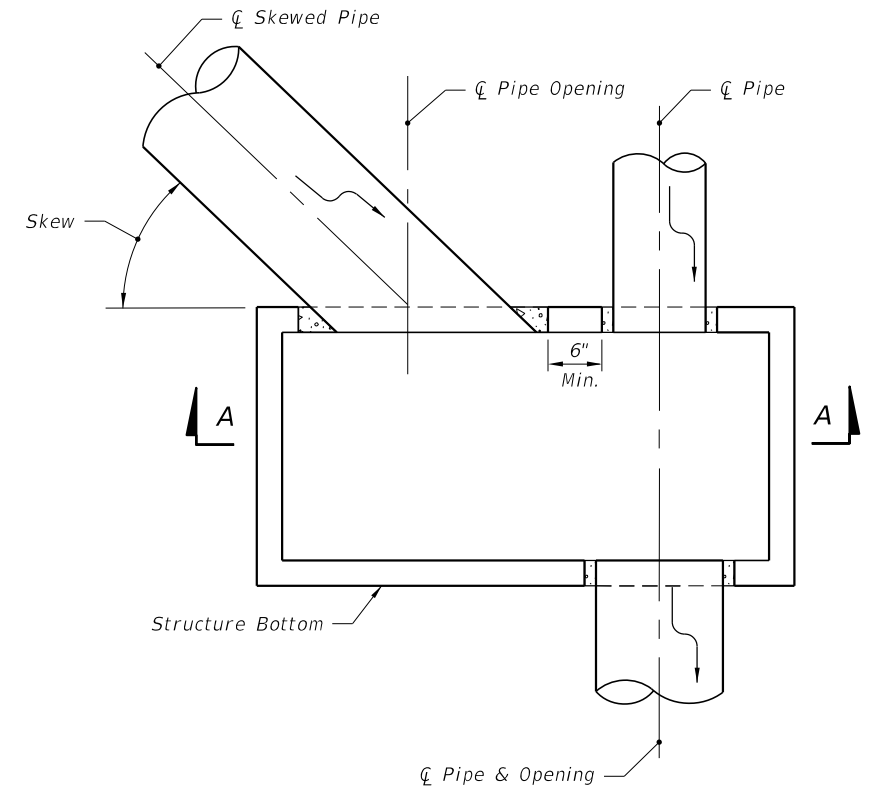

**PLAN VIEW FOR SKEWS  $> 45^\circ$   
(Not Centered)**

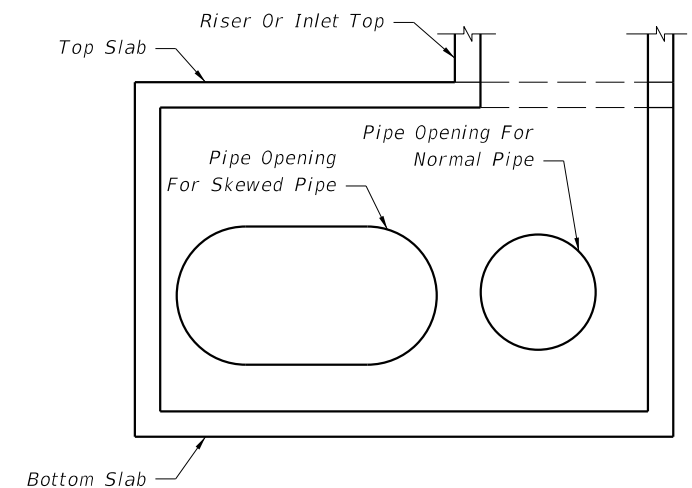

**SECTION AA**  
(Pipes Not Shown For Clarity)

**DETAILS FOR SKEWED PIPES IN RECTANGULAR STRUCTURES**

10/11/2016 10:16:02 AM

LAST REVISION 07/01/12	REVISION	DESCRIPTION:	 <b>FY 2017-18 DESIGN STANDARDS</b>	<b>SUPPLEMENTARY DETAILS FOR MANHOLES &amp; INLETS</b>	INDEX NO. <b>201</b>	SHEET NO. <b>5 of 5</b>
---------------------------	----------	--------------	--	--	-------------------------	----------------------------