

BARRIER DELINEATOR SPACING	
Distance - Edge of Travel Lane to Face of Railing	Spacing (Ft.)
< 4'	40'
4' to 8'	80'
> than 8'	None Required

TRAFFIC RAILING NOTES

This railing has been structurally evaluated to be equivalent or greater in strength to other safety shape railings which have been crash tested to NCHRP Report 350 TL-4 Criteria.

CONCRETE AND REINFORCING STEEL : See Structures Plans, General Notes.

GUARDRAIL : For Guardrail connection details, see Index No. 400.

RAILINGS ON RETAINING WALLS : If the Traffic Railing is to be provided on a retaining wall, the railing section will be the same as shown on Index No. 422, Sheet 2. All other details such as the guardrail transition attachment, the maximum spacing of the 3/4" open joints and 1/2" V-Groove shall apply.

BARRIER DELINEATORS : Barrier Delineators shall meet Specification Section 993. Install Barrier Delineators on top of the Traffic Railing 2" from the face on the traffic side at the spacing shown in the table above. Barrier Delineator color (white or yellow) shall match the color of the near edgeline. The cost of the Barrier Delineators shall be included in the Contract Unit Price for the Traffic Railing.

V-GROOVES : Construct 1/2" V-Grooves plumb and provide at 30'-0" maximum intervals as shown. Space V-Grooves equally between 3/4" Open Joints and/or Deck Joints and at V-Groove locations on Retaining Wall footings.

NAME, DATE, AND BRIDGE NUMBER : The Name and Bridge Number shall be placed on the Traffic Railing so as to be seen on the driver's right side when approaching the bridge. The Date shall be placed on the driver's left side when approaching the bridge. The Name shall be as shown in the General Notes in the Structures Plans. The Date shall be the year the bridge is completed. For a widening when the existing railing is removed, use both the existing date and the year of the widening. Black plastic letters and figures 3" in height may be used, as approved by the Engineer, in lieu of the letters and figures formed by 3/8" V-Grooves. V-Grooves shall be formed by preformed letters and figures.

JOINTS : See Plans, Superstructure, Approach Slab and Retaining Walls Sheets for actual dimensions and joint orientation. Provide open Railing Joints at Deck Expansion Joint locations matching the dimensions of the Deck Joint. For treatment of Railings on skewed bridges see Index No. 420.

Provide 3/4" Intermediate Open Joints at :

- (1) - Superstructure supports where slab is continuous.
- (2) - Ends of approach slabs when adjacent to retaining walls and at expansion joints on retaining wall junction slabs.

CROSS REFERENCE:
For Section A-A, View B-B and View C-C, see Sheet 2.
For Detail "A" see Sheet 3.

6/23/2015 4:31:45 PM

LAST REVISION 01/01/14	REVISION	DESCRIPTION:	 2016 DESIGN STANDARDS	TRAFFIC RAILING - (42" VERTICAL SHAPE)	INDEX NO. 422	SHEET NO. 1 of 3
---------------------------	----------	--------------	--	---	-------------------------	----------------------------

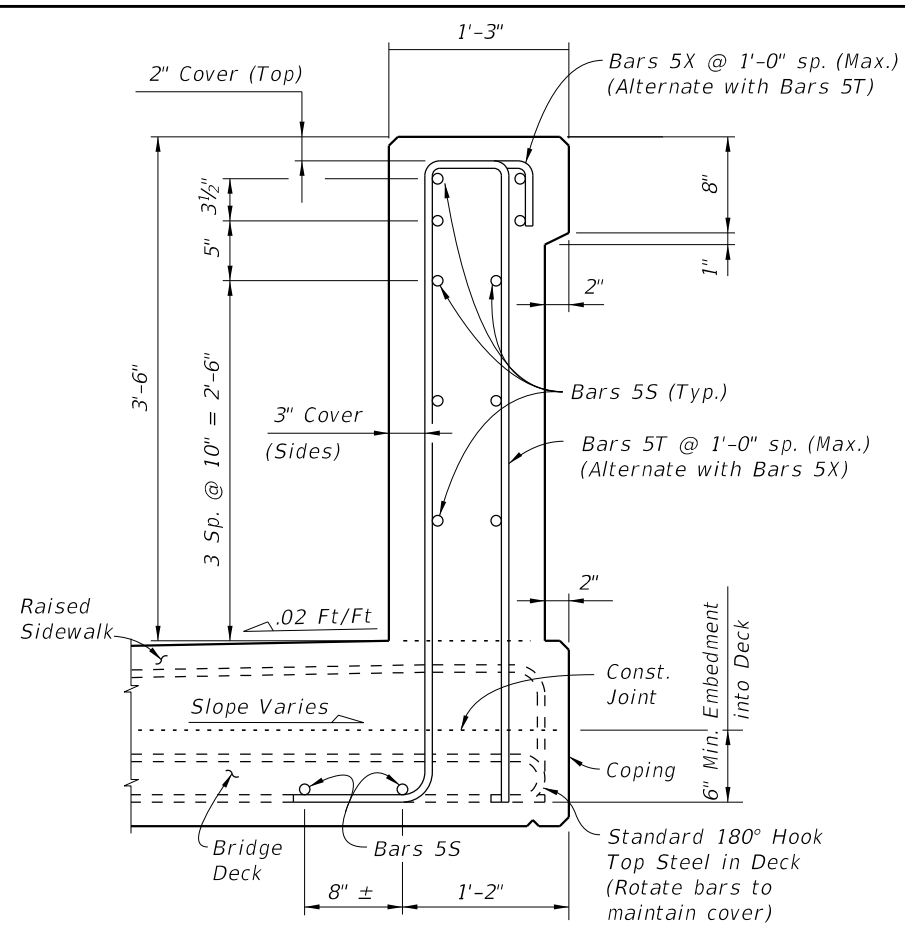

SECTION A-A
TYPICAL SECTION THRU TRAFFIC RAILING
SECTION THRU BRIDGE DECK SHOWN

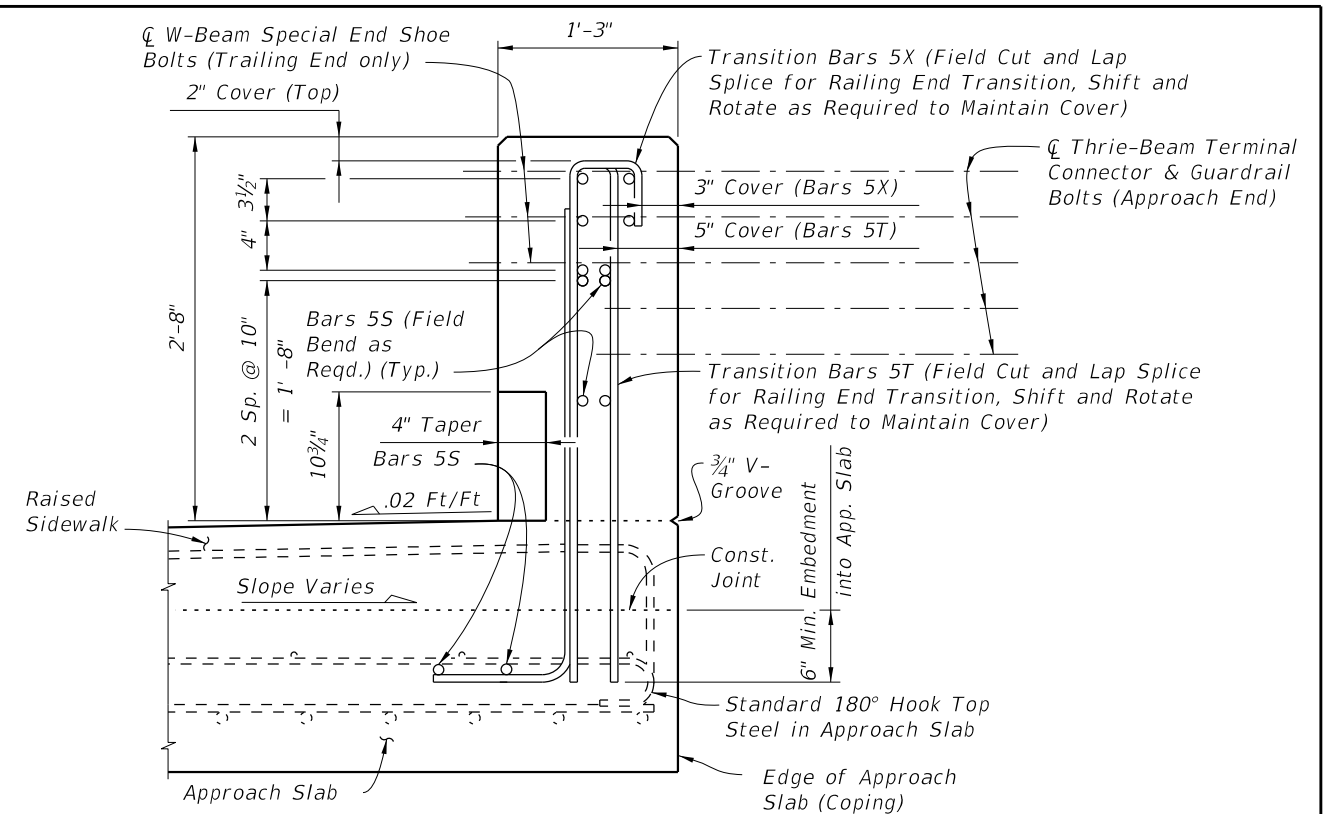

VIEW B-B
(End View of Traffic Railing, Approach Slab shown,
Retaining Wall Junction Slab similar)

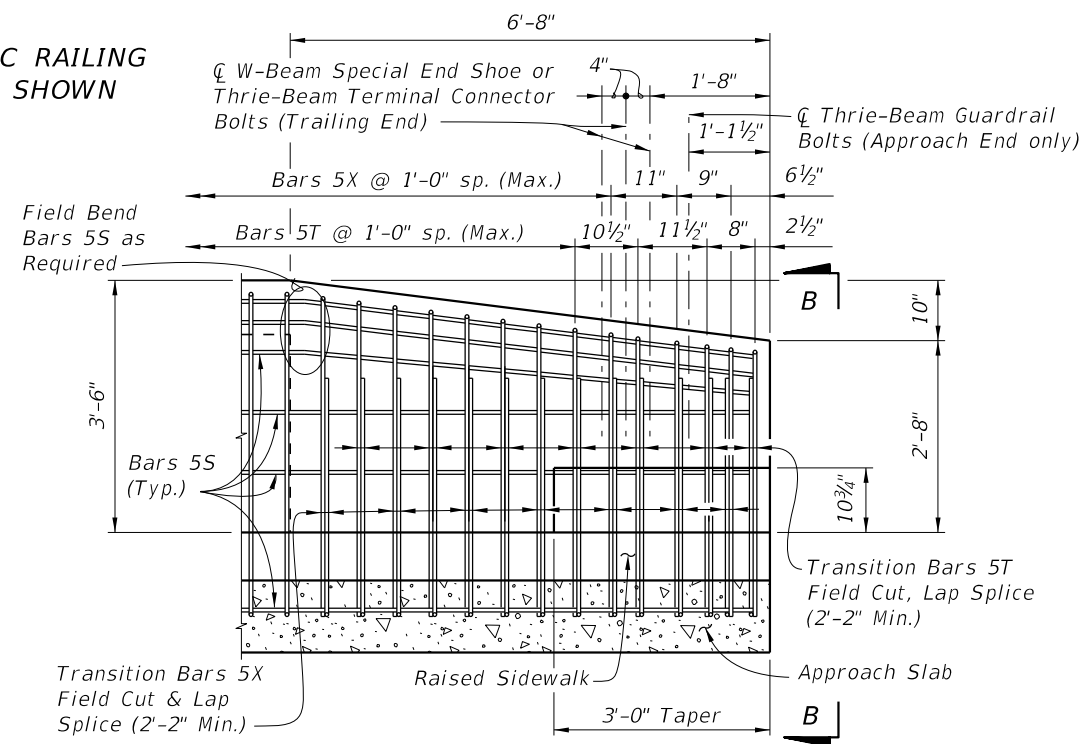

VIEW C-C
RAILING END TRANSITION
(Guardrail Not Shown For Clarity)

NOTES:
Begin placing Railing Bars 5T and 5X on Approach Slab at the railing end and proceed toward Begin or End Bridge to ensure placement of guardrail bolt holes. If required, adjustments to the bar spacing for Bars 5T and 5X shall be made immediately adjacent to Begin or End Bridge. Shift and rotate Bars 5T and 5X as required to maintain cover in Railing End Transition.

Omit Railing Taper, End Transition and Guardrail if Concrete Barrier Wall is used beyond the Approach Slab or Retaining Wall. See Structures Plans, Plan and Elevation Sheet and Roadway Plans. If Taper and Railing End Transition is omitted, extend Typical Section to end of the Approach Slab or limiting station on Retaining Wall, and space Bars 5T and 5X at 1'-0" (Typ.)

CROSS REFERENCE:
For location of Section A-A, View B-B and View C-C, see Sheet 1.

6/23/2015 4:31:46 PM

LAST REVISION 07/01/14	REVISION	DESCRIPTION:	 2016 DESIGN STANDARDS	TRAFFIC RAILING - (42" VERTICAL SHAPE)	INDEX NO. 422	SHEET NO. 2 of 3
---------------------------	----------	--------------	--	---	-------------------------	----------------------------

CONVENTIONAL REINFORCING STEEL BENDING DIAGRAMS

BILL OF REINFORCING STEEL		
MARK	SIZE	LENGTH
S	5	As Reqd.
T	5	10'-8"
X	5	6'-9"

ROADWAY CROSS-SLOPE	ØA	
	LOW GUTTER	HIGH GUTTER
0% to 2%	90°	90°
2% to 6%	87°	83°
6% to 10%	84°	96°

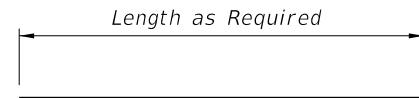

BAR 5S

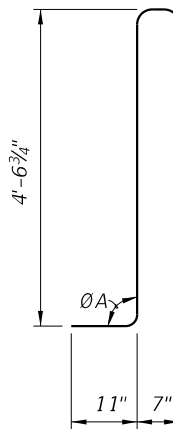

STIRRUP BAR 5T

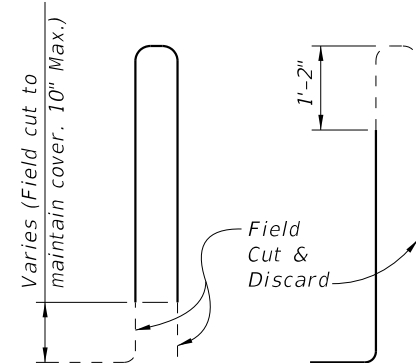

TRANSITION STIRRUP BARS 5T
To Be Field Cut (7 of each required per Railing End Transition)

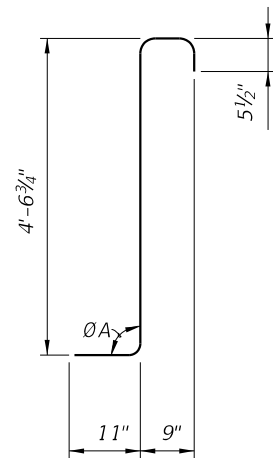

STIRRUP BAR 5X

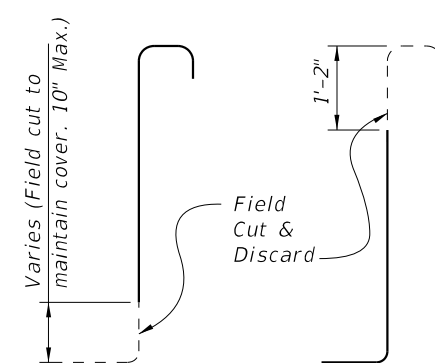

TRANSITION STIRRUP BARS 5X
To Be Field Cut (7 of each required per Railing End Transition)

REINFORCING STEEL NOTES:

- All bar dimensions in the bending diagrams are out to out.
- The 4'-6 3/4" vertical dimension shown for Bars 5T and 5X is based on a bridge deck with a 6" thick x 6' wide raised sidewalk at low side of deck, 2% deck cross slope and a counter 2% raised sidewalk cross slope. If the raised sidewalk thickness, width or cross slope vary from the above amounts, adjust this dimension accordingly to achieve a 6" minimum embedment into the bridge deck. See Structures Plans, Superstructure and Approach Slab Sheets.
- The reinforcement for the railing on a retaining wall shall be the same as detailed above with ØA = 90°.
- All reinforcing steel at the open joints shall have a 2" minimum cover.
- Bars 5S may be continuous or spliced at the construction joints. Bar splices for Bars 5S shall be a minimum of 2'-2".
- The Contractor may utilize Welded Wire Reinforcement (WWR) when approved by the Engineer. WWR must consist of Deformed wire meeting the requirements of Specification Section 931.

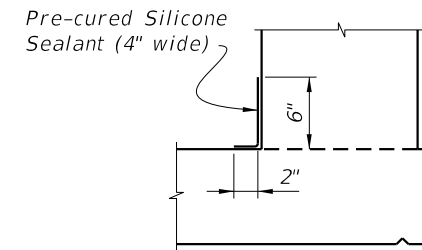

DETAIL "A" - SECTION AT INTERMEDIATE OPEN JOINT

INTERMEDIATE JOINT SEAL NOTES:

- At Intermediate Open Joints, seal the lower 6" portion of the open joint with Pre-cured Silicone Sealant in accordance with Specification Section 932.
- Apply sealant prior to any Class V finish coating and remove all curing compound and loose material from the surface prior to application of bonding agent.
- The cost of the Pre-cured Silicone Sealant shall be included in the Contract Unit Price for the Traffic Railing.

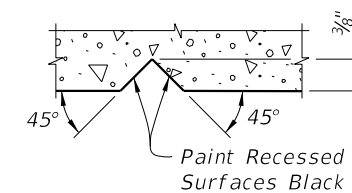

SECTION THRU RECESSED "V" GROOVE TO FORM INSCRIBED LETTERS AND FIGURES

ESTIMATED TRAFFIC RAILING QUANTITIES		
ITEM	UNIT	QUANTITY
Concrete	CY/LF	0.145
Reinforcing Steel	LB/LF	30.68

(The above quantities are based on a 6" thick x 6' wide raised sidewalk at low side of deck, 2% deck cross slope and counter 2% sidewalk cross slope)

6/23/2015 4:31:49 PM

LAST REVISION	DESCRIPTION:
07/01/13	



TRAFFIC RAILING - (42" VERTICAL SHAPE)

INDEX NO.	SHEET NO.
422	3 of 3