

Sumps Are To Be Constructed Unless Excluded In The Plans.  
 Weep Hole To Be Constructed Only Where Called For In The Plans.  
 For Additional Sump Bottom Information See Index No. 201.

**LONGITUDINAL SECTION**

**GENERAL NOTES**

1. Pipe shall be any of the optional types permitted in Section 443 of the Specifications unless otherwise restricted in the plans. Dissimilar types of pipe will not be permitted in a continuous run of pipe.
2. Concrete pipe shall be placed with the slots positioned on sides.
3. Alignment joints are standard (gaskets not required). Recorrugation of metal pipe ends not required.
4. The contractor may submit other methods of providing slots having equal or greater area of opening, for approval by the Engineer.
5. Filter fabric shall be Type D-3 meeting the requirements of Section 985. All filter fabric joints shall lap a minimum of one (1) foot.
6. The standard cross section shall be constructed unless other section(s) described or detailed in the plans.
7. For supplemental details see Index No. 280.
8. The contractor shall take the necessary precautions to prevent contamination of the trench with sand, silt and foreign materials.
9. French drains shall be paid for under the contract unit price for French Drains, LF. The unit price shall include the cost of pipe, pipe plugs, pipe fittings, coarse aggregate and filter fabric in place, and the cost for trench excavation, backfill and compaction. The unit price shall also include the cost for disposal of surplus excavated materials and cost for restoration of pavement removed or damaged by french drain construction, but shall not include payments for items paid for elsewhere.

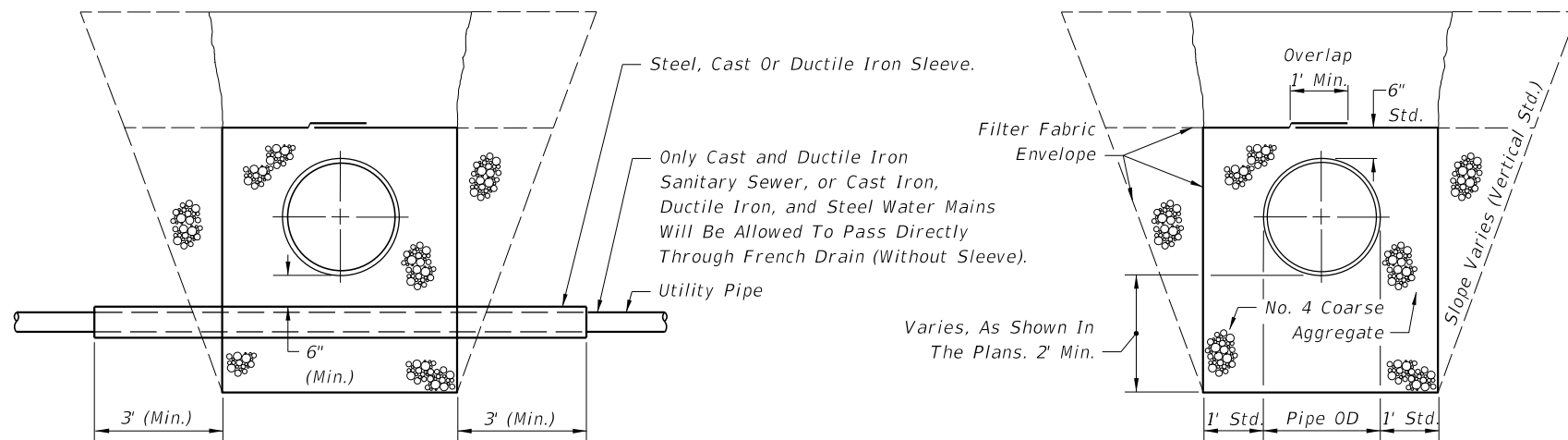

ROUND PIPE SHOWN  
 UTILITY PIPES THRU FRENCH DRAIN

ROUND PIPE SHOWN  
 STANDARD CROSS SECTION (ENLARGED)

**FRENCH DRAIN SYSTEM**

**DESIGN NOTES**

1. Pipe invert should be at or above the water table whenever possible.
2. French drains with minor dimensional changes or otherwise different from the standard cross-section shall be either described or detailed in the plans. French drains with significantly different cross-sections shall be detailed in the plans.

6/8/2015 10:02:20 AM

LAST REVISION 07/01/10	REVISION	DESCRIPTION:	 <b>2016</b> <b>DESIGN STANDARDS</b>	<b>FRENCH DRAIN</b>	INDEX NO. <b>285</b>	SHEET NO. <b>1 of 2</b>
---------------------------	----------	--------------	---	---------------------	-------------------------	----------------------------

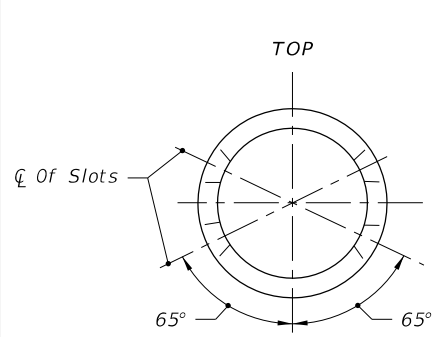

15"-30"

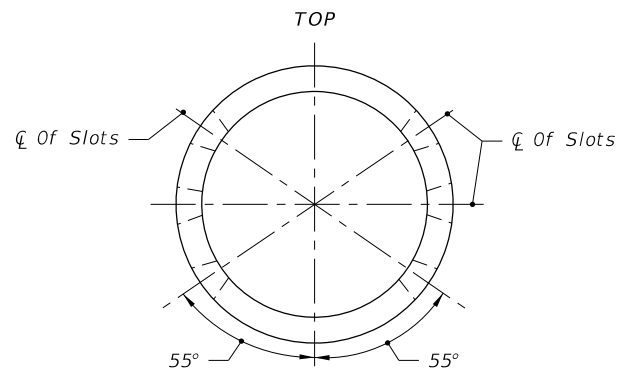

36"-72"

ELLIPTICAL PIPE		
Pipe Size	Slot Cut	
	Opening c	
	Min.	Max.
14"x23"	10"	12"
19"x30"	14"	16"
24"x38"	14"	16"
29"x45"	20"	22"
34"x53"	20"	22"
38"x60"	20"	22"

ROUND PIPE		
Pipe Size	Slot Cut	
	Opening c	
	Min.	Max.
15"	12"	14"
18"	12"	14"
24"	16"	18"
30"	16"	18"
36"	22"	24"
42"	22"	24"
48"	22"	24"
54"	24"	26"
60"	24"	26"
66"	24"	26"
72"	24"	26"

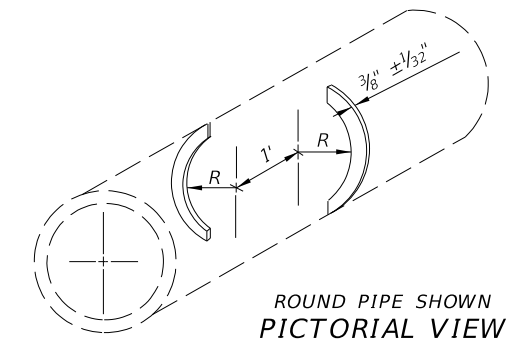

ROUND PIPE SHOWN PICTORIAL VIEW

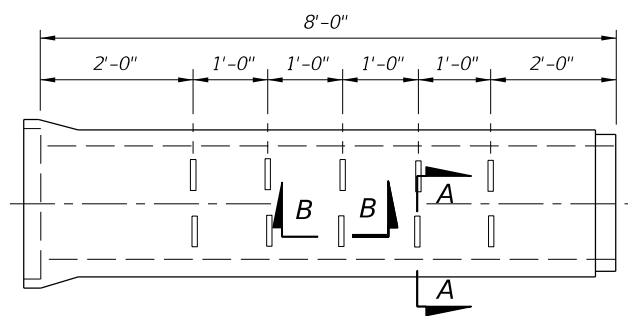

SIDE VIEW

OPTION A - ROUND PIPE

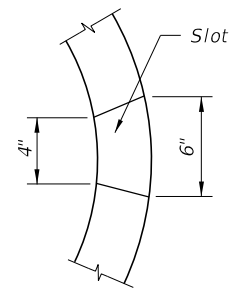

SECTION AA

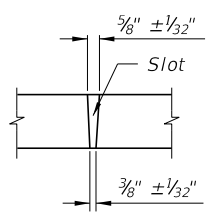

SECTION BB

A curved cut is acceptable provided the control dimension is maintained (Typical For Elliptical & Round Pipe)

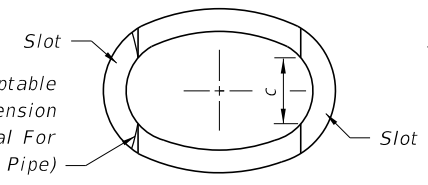

ELLIPTICAL PIPE SECTION AA

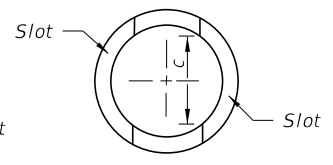

ROUND PIPE SECTION AA

OPTION B - ROUND OR ELLIPTICAL PIPE

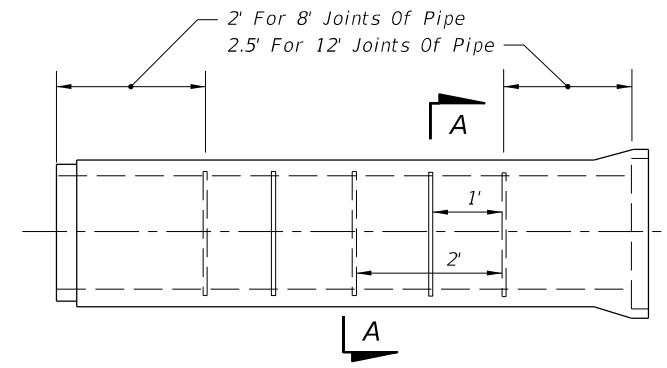

SIDE VIEW

6/8/2015 10:02:21 AM