

STEEL STRAIN POLE NOTES

- 1) Designed in accordance with FDOT Structures Manual.
- 2) Perform all welding in accordance with the American Welding Society Structural Welding Code (Steel) ANSI/AWS D1.1 (current edition). No Field welding is permitted on any part of the pole.
- 3) See Standard Index No. 17727 for grounding and span wire details.
- 4) Foundation Materials:
 - a. Reinforcing Steel: ASTM A615 Grade 60.
 - b. Concrete: Class IV, (Drilled Shaft) 4,000 psi (f'c) minimum Compressive Strength at 28-days for all environmental classifications.
 - c. Anchor Bolts: ASTM F1554 Grade 55 with ASTM A563 Grade A heavy-hex nuts and plate washers (all galvanized in accordance with ASTM F2329).
- 5) Strain Pole Specifications:
 - a. Poles: ASTM A1011 Grade 50, 55, 60 or 65 (less than 1/4") or ASTM A572 Grade 50, 55, 60, or 65 (1/4" and over) or ASTM A595 Grade A (55 ksi yield) or Grade B (60 ksi yield).
 - b. Steel Plates: ASTM A36.
 - c. Weld Metal: E70XX.
 - d. Bolts: A325, Type 1. Hole Diameter: Bolt diameter plus 1/16".
 - e. Base Plate: Hole Diameter; anchor bolt diameter plus 1/2".
 - f. Handhole: Frame; ASTM A709 Grade 36 or ASTM A36, Cover; ASTM A1011 Grade 50, 55, 60 or 65.
 - g. Aluminum Caps and Covers: ASTM B-26 (319-F).
 - h. Stainless Steel Screws: AISI Type 316.
 - i. Galvanization: All nuts, bolts and washers; ASTM F2329, All other steel; ASTM A123.
- 6) Pole Notes:
 - a. See the Signalization Plans for clamp spacing, cable sizes and forces, signal and sign mounting locations and details.
 - b. Tapered with the diameter changing at a rate of 0.14 inch per foot.
 - c. Transverse welds are allowed only at the base.
 - d. Poles constructed out of two or more sections with overlapping splices are not permitted.
 - e. Locate the handhole 180 degrees from 2-inch wire entrance pipe.
 - f. Furnish each pole with a 2"x4" (max) aluminum identification tag. Submit details for approval. Secure to pole with 0.125" stainless steel rivets or screws. Locate Identification Tag on the inside of pole and visible from handhole. Include the following information:
Financial Project ID, Pole Type, Pole Height, Manufacturer's Name, F of Steel and Base Wall Thickness.
- 7) One hundred percent of full-penetration groove welds and a random 25 percent of partial penetration groove welds shall be inspected. Full-penetration groove weld inspection shall be performed by nondestructive methods of radiography or ultrasonics.
- 8) In accordance with specification 5-1.4.2, shop drawings are only required for additions, deletions, or modifications to this Design Standard.
- 9) Verify CSL access tubes will not interfere with anchor bolt installation before excavating the shaft. When CSL access tube locations conflict with anchor bolt locations, move the CSL access tube location ± two inches along the inner circumference of the reinforcing cage. Notify the Engineer before excavating the shaft if the CSL access tube locations cannot be moved out of conflict with anchor bolt locations.

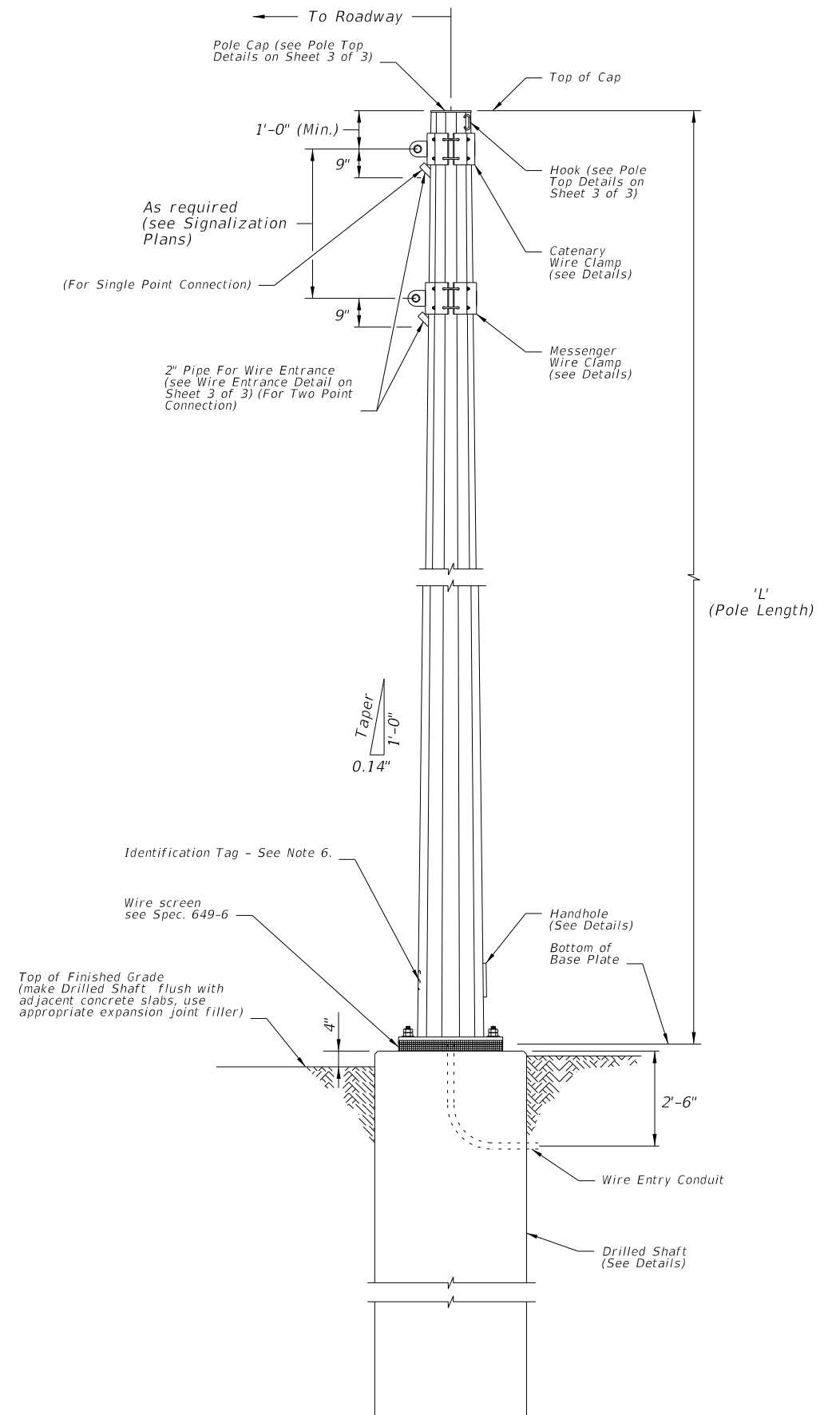

ELEVATION

ELEVATION AND NOTES

C:\projects\standards\roadway\17700-s\17723-01.dgn r1960/h 11:49:19 AM 12/30/2011

LAST REVISION	REVISION	DESCRIPTION:		FDOT DESIGN STANDARDS FY 2012/2013	STEEL STRAIN POLE	INDEX NO.	SHEET NO.
01/01/12						17723	1

12/30/2011 11:49:20 AM r1960/h C:\projects\standards\roadway\17700-s\17723-02.dgn

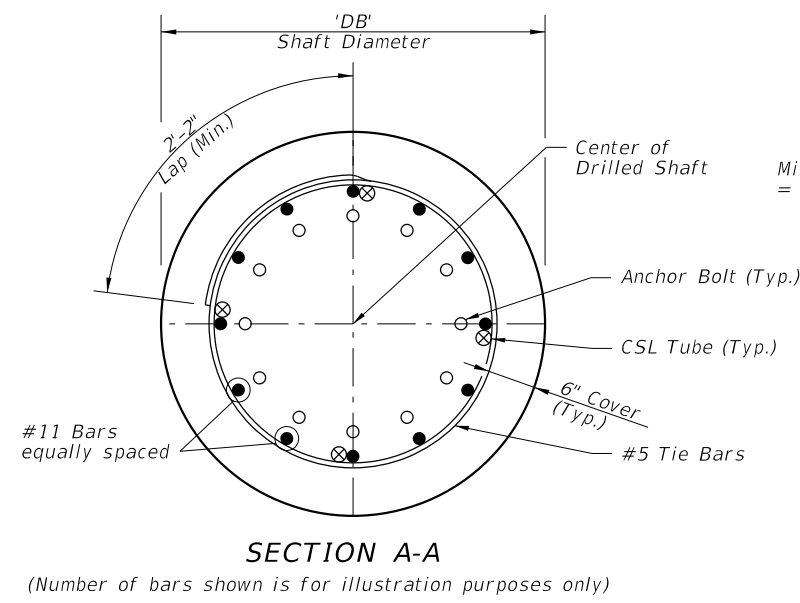

SECTION A-A

(Number of bars shown is for illustration purposes only)

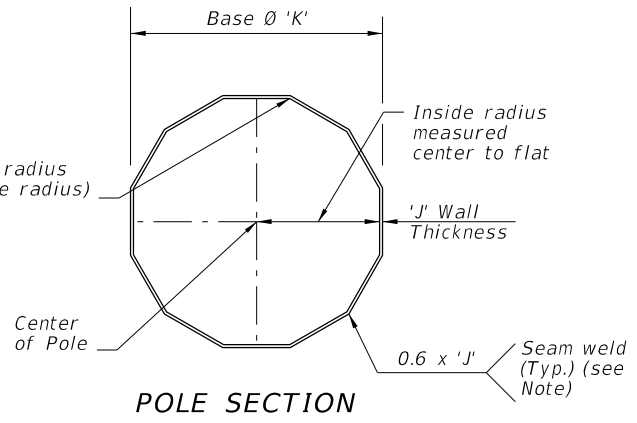

POLE SECTION

NOTE:
Longitudinal seam welds within 6" of circumferential welds shall be complete penetration welds.

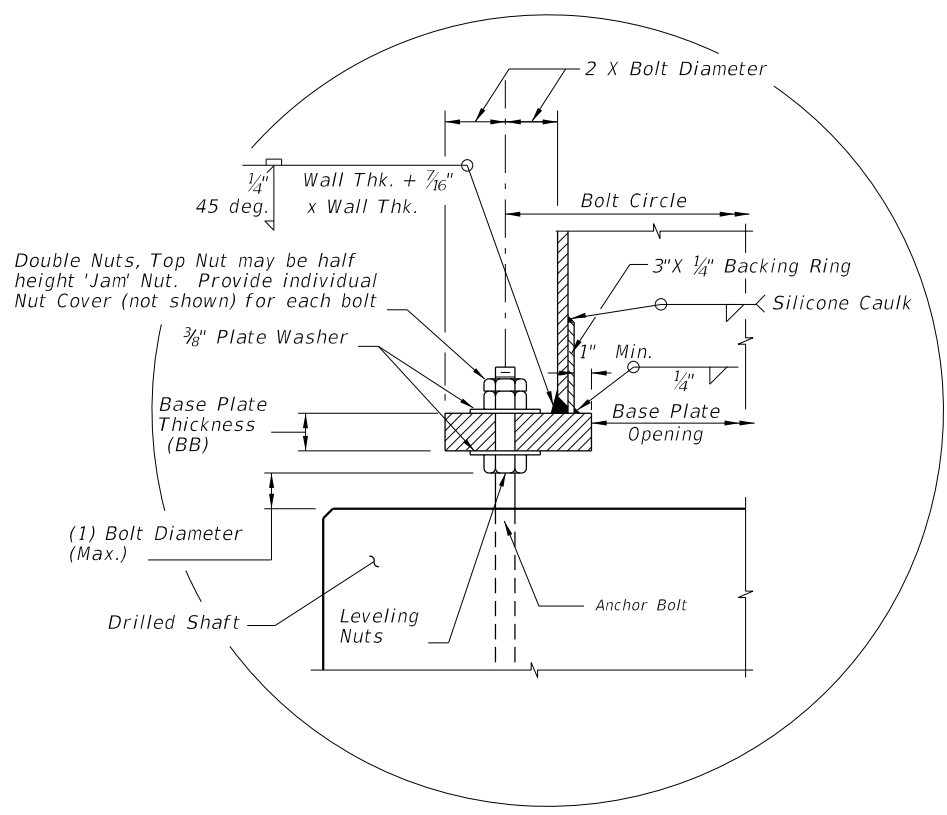

DETAIL C

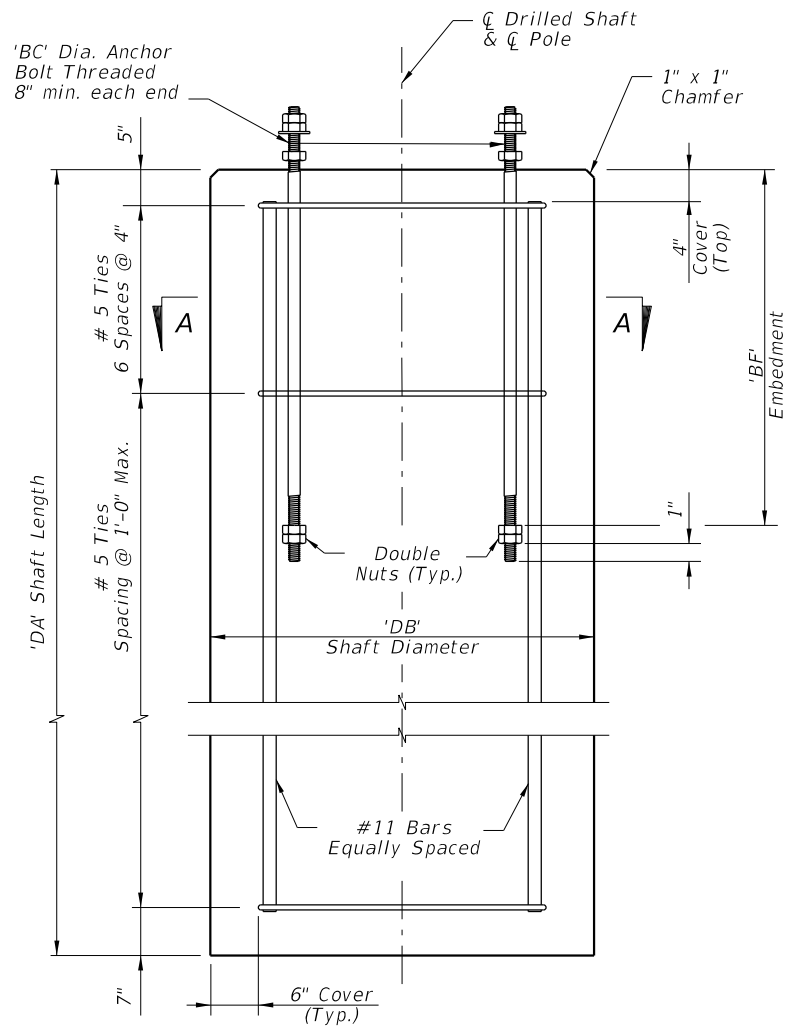

DRILLED SHAFT ELEVATION

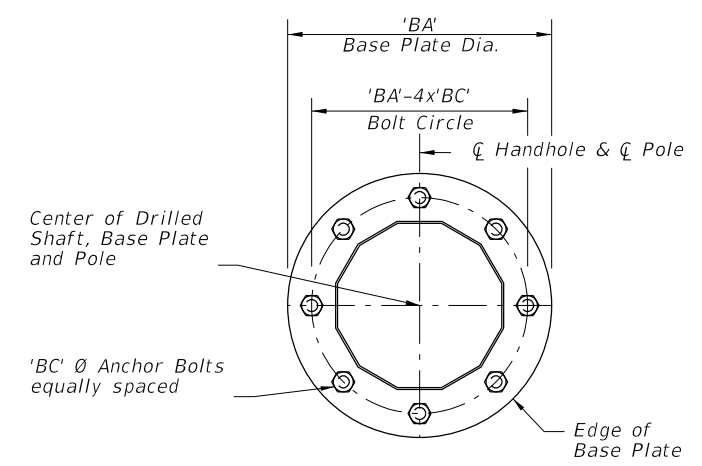

SECTION B-B

NOTE:
Number of bolts shown for illustration purposes only.

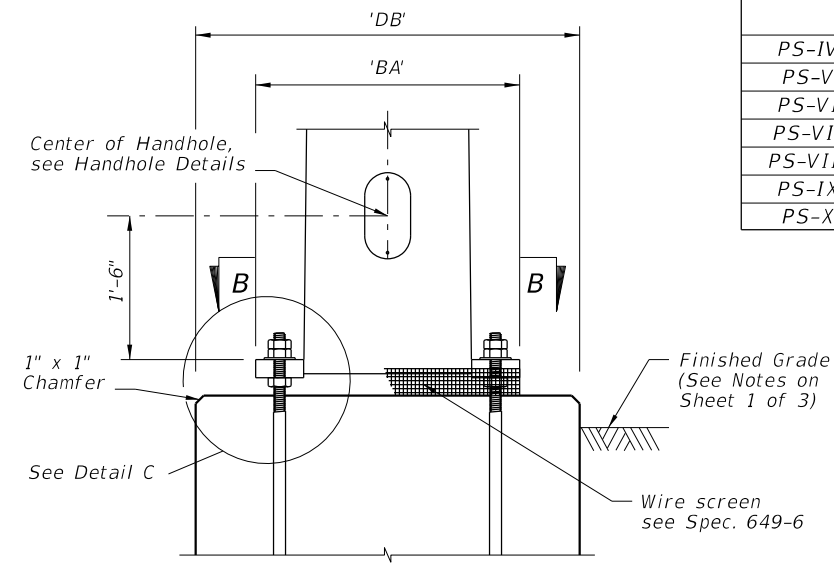

PARTIAL ELEVATION

(Showing Base Plate, Anchor bolts and Handhole)

POLE TYPE	MAXIMUM ALLOWABLE MOMENT (kip-ft)	POLE		BASE CONNECTION				SHAFT			
		J (in)	K (in)	No. of Bolts	BA (in)	BB (in)	BC (in)	BF (in)	DA (FT)	DB (FT)	No. of #11 bars
PS-IV	95.4	0.250	14	8	25	2.50	1 3/8	60	14	4	14
PS-V	158.9	0.313	16	10	28	2.50	1 1/2	60	15	4	14
PS-VI	203.6	0.313	18	12	30	2.50	1 1/2	60	16	4	14
PS-VII	280.3	0.313	21	14	33	2.50	1 1/2	60	16	4.5	16
PS-VIII	338.0	0.313	23	16	35	2.50	1 1/2	60	17	4.5	16
PS-IX	400.9	0.313	25	12	39	3.00	1 3/4	60	17	5	18
PS-X	469.1	0.313	27	14	41	3.00	1 3/4	60	18	5	18

FOUNDATION NOTES:
The foundations for Steel Strain Poles are designed based upon the following conservative soil criteria which covers the great majority of soil types found in Florida:
Classification = Cohesionless (Fine Sand)
Friction Angle = 30 Degrees (30°)
Unit Weight = 50 pcf (assumed saturated)
Only in cases where the Designer considers the soil types at the specific site location to be of lesser strength properties should an analysis be required. Auger borings, SPT borings or CPT soundings may be utilized as needed to verify the assumed soil properties, and at relatively uniform sites, a single boring or sounding may cover several foundations. Furthermore, borings in the area that were performed for other purposes may be used to confirm the assumed soil properties.

BASE AND FOUNDATION DETAILS AND TABLE OF VARIABLES

Cable Diameter (in.)	Minimum Breaking Strength (kip)	Plate Thickness (in.)
1/2	25	1
7/16	18	7/8
3/8	11.5	3/4
1/4	3.15	3/8

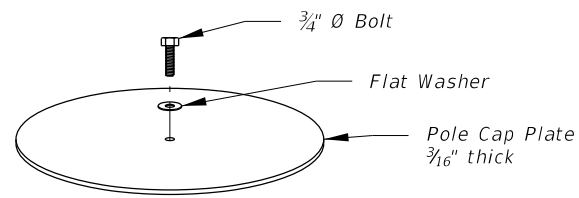

NOTE: A properly sized Service Head (Weather Head), shall be installed and fastened securely on to the standard pipe for each pole location. At locations other than service entrance, the service head face is to be left closed to outside atmosphere. Service entrance installation per Index No. 17727.

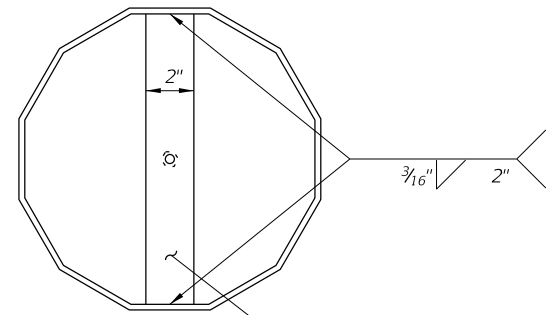

TOP VIEW

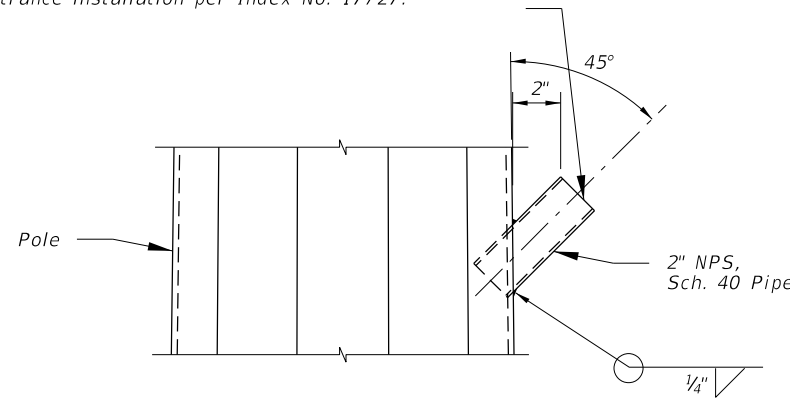

WIRE ENTRANCE DETAILS

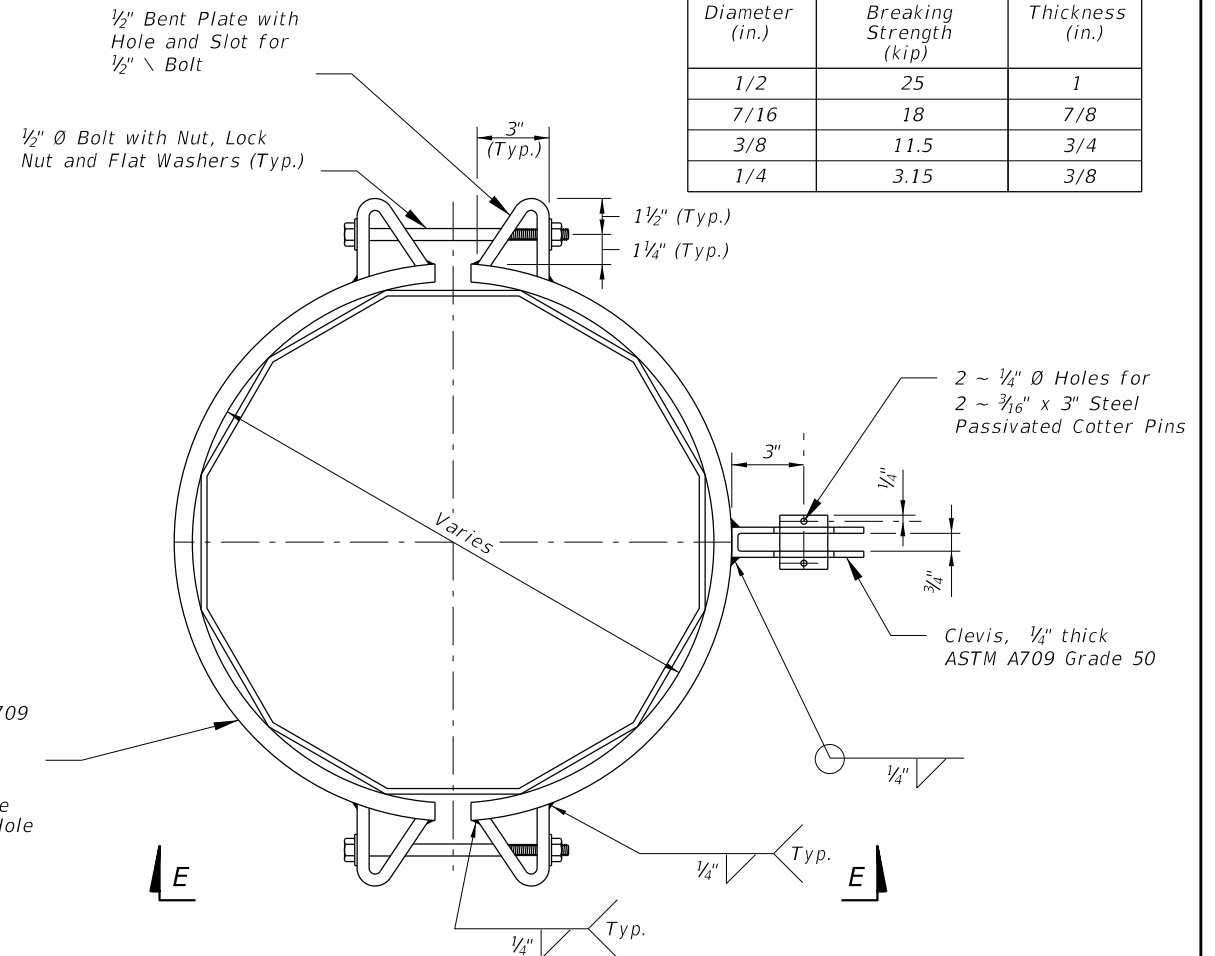

CATENARY AND MESSENGER WIRE CLAMPS

NOTE: Clamps have been sized for Design Cable Loads shown in the Table, and a Maximum Pole Diameter at the Clamp location of 2'-1".

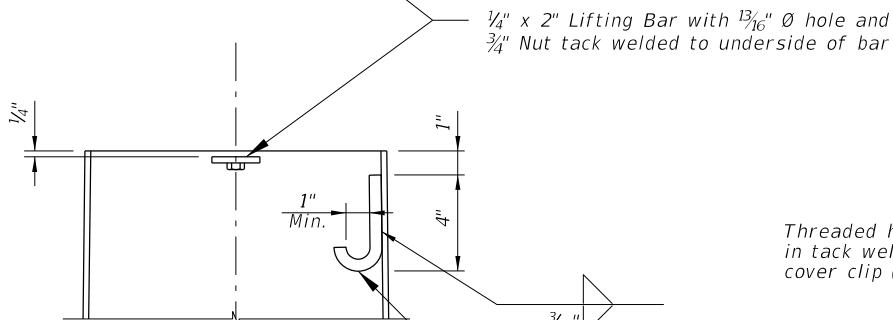

POLE TOP CUT-AWAY (Option 'a')

1/4" x 2" Lifting Bar with 1 3/16" Ø hole and 3/4" Nut tack welded to underside of bar

'J' Hook for wiring Hole Frame made 1/2" Ø commercial grade hot rolled bar welded to inside of pole. Full Penetration Weld

4" x 3/8" Hand Hole Frame made 1/2" Ø commercial grade hot rolled bar welded to inside of pole. Full Penetration Weld

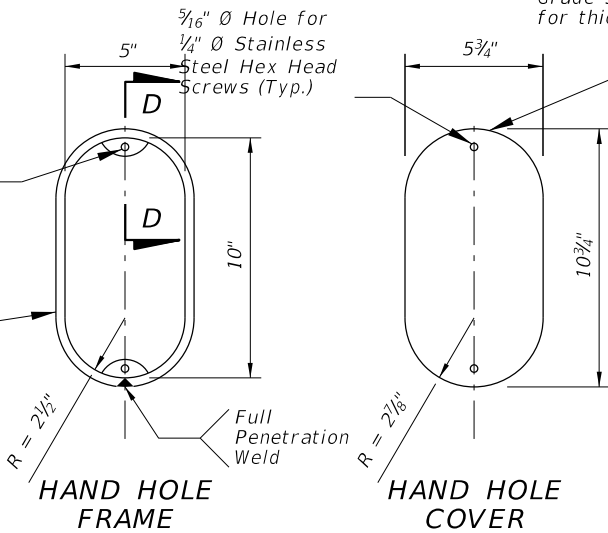

HAND HOLE FRAME

HAND HOLE COVER

Steel Clamp, ASTM A709 Grade 50, see Table for thickness

11 Gage Hand Hole Cover

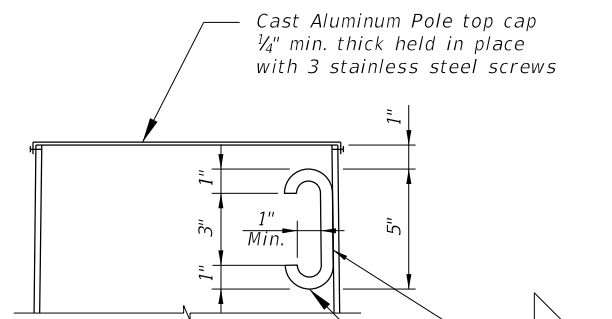

POLE TOP CUT-AWAY (Option 'b')

'C' Hook for wiring and lifting, 1/2" Ø commercial grade hot rolled bar welded to inside of pole.

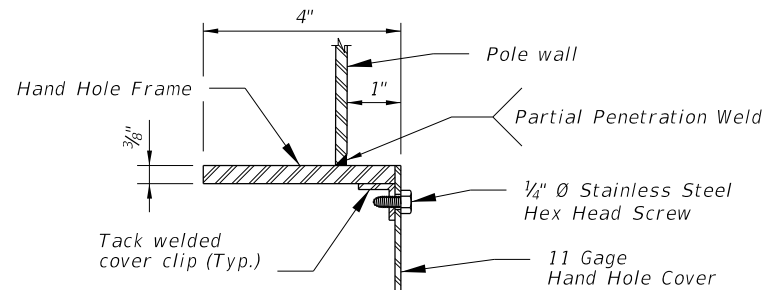

SECTION D-D (thru Hand Hole)

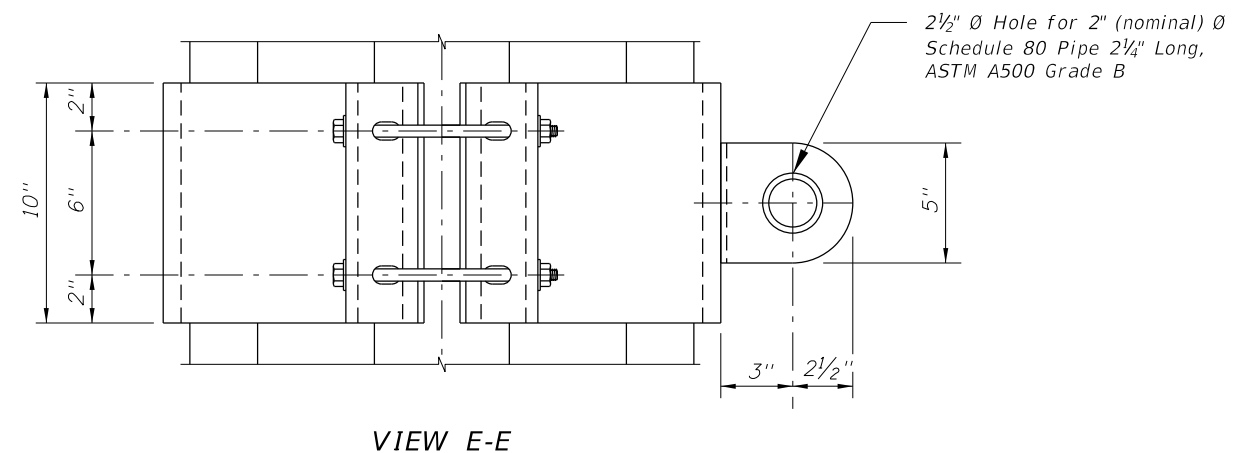

VIEW E-E

POLE TOP NOTE:
Any combination of the above two options may be used, provided both lifting and wiring is accommodated.

ATTACHMENT DETAILS

C:\projects\standards\roadway\17700-s\17723-03.dgn 11:49:20 AM r1960/h 12/30/2011

LAST REVISION	DESCRIPTION:	 FDOT DESIGN STANDARDS FY 2012/2013	STEEL STRAIN POLE	INDEX NO.	SHEET NO.
01/01/09				17723	3