

PLAN (INLET TYPE 2 SYMMETRICAL ABOUT CL)

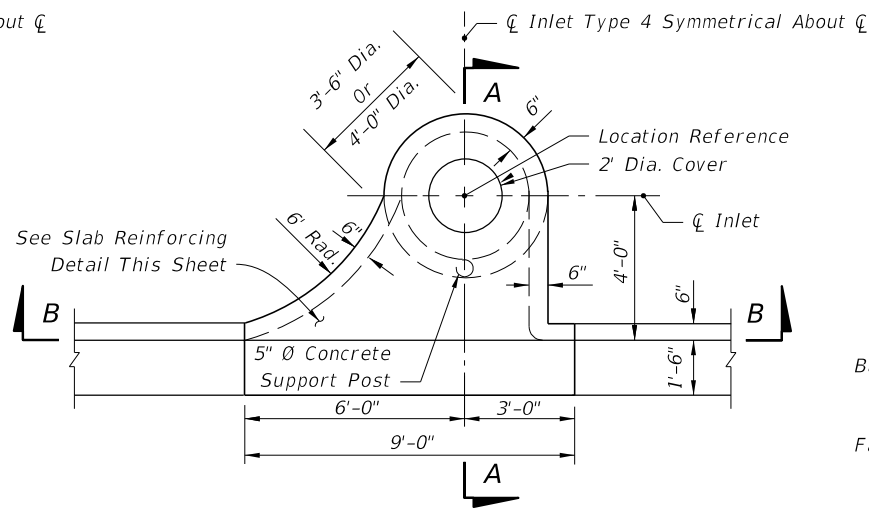

PLAN (INLET TYPE 4 SYMMETRICAL ABOUT CL)

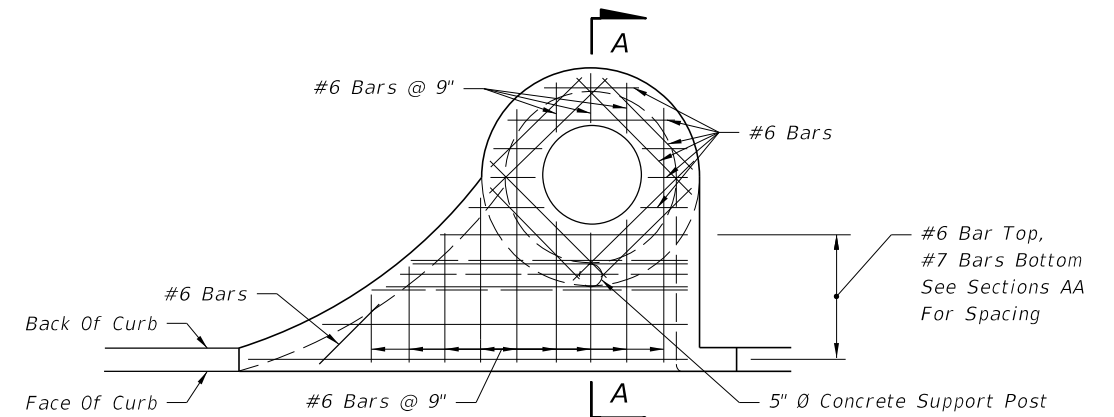

INLETS TYPES 1 AND 3

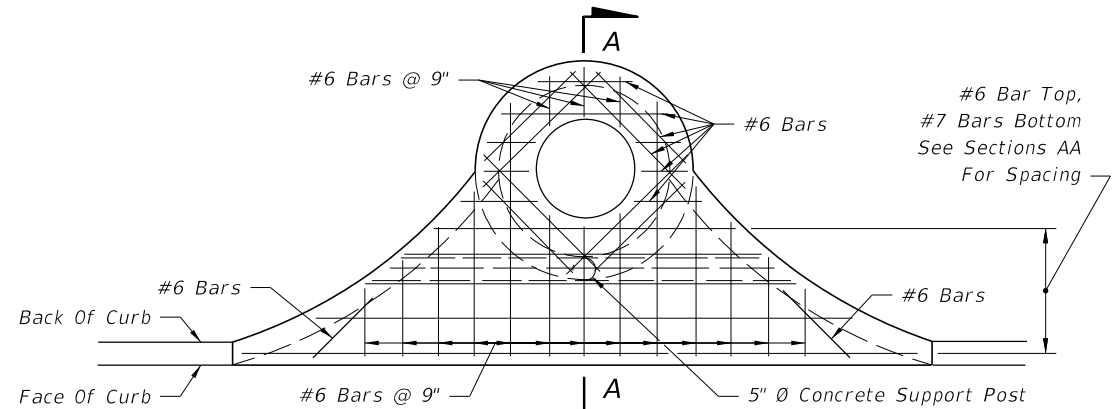

INLETS TYPES 2 AND 4
SLAB REINFORCING

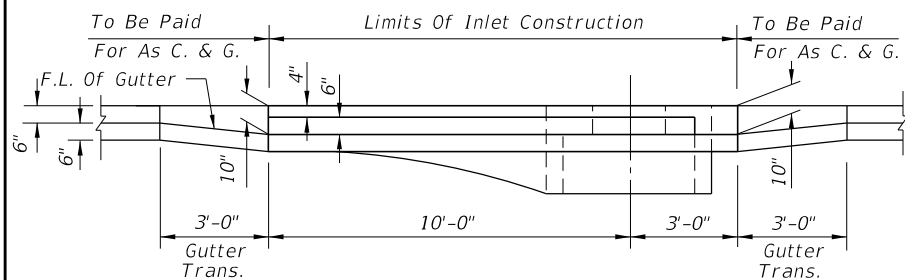

SECTION BB (INLET TYPE 2 SYMMETRICAL ABOUT CL)
INLETS TYPES 1 AND 2

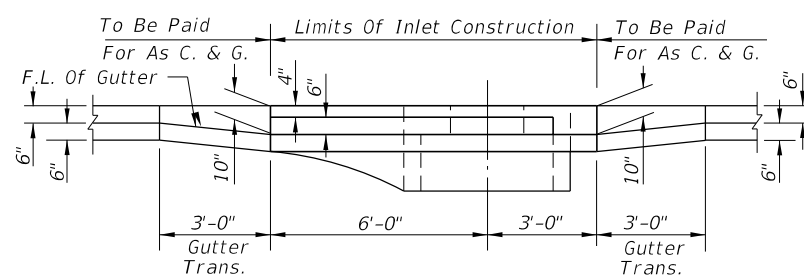

SECTION BB (INLET TYPE 4 SYMMETRICAL ABOUT CL)
INLETS TYPES 3 AND 4

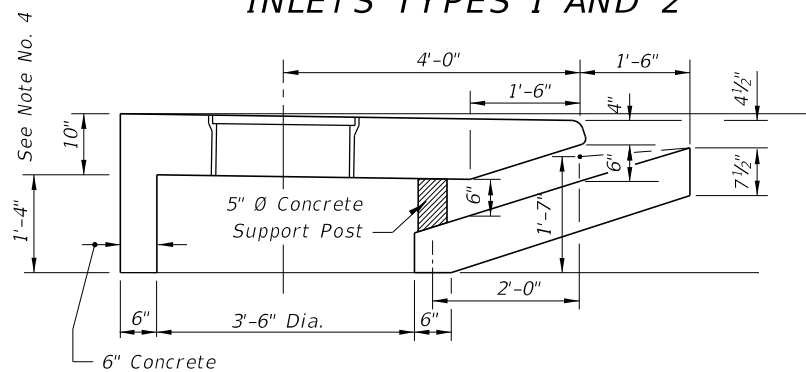

DIMENSIONAL SECTION

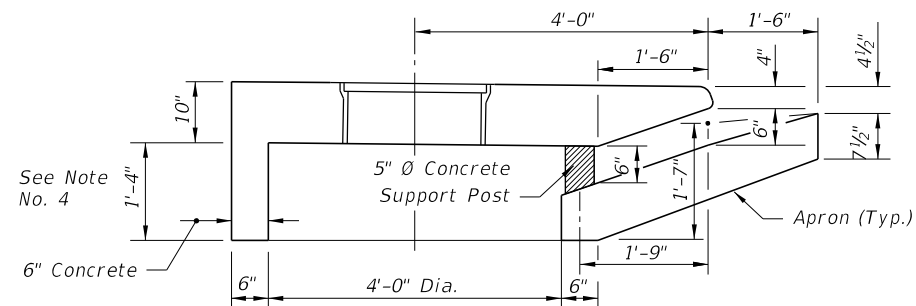

DIMENSIONAL SECTION

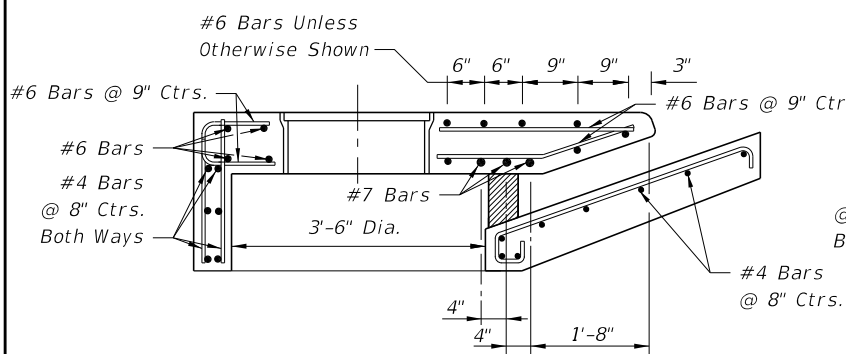

REINFORCING SECTION
3'-6" DIA. STRUCTURE BOTTOM (SECTION AA)

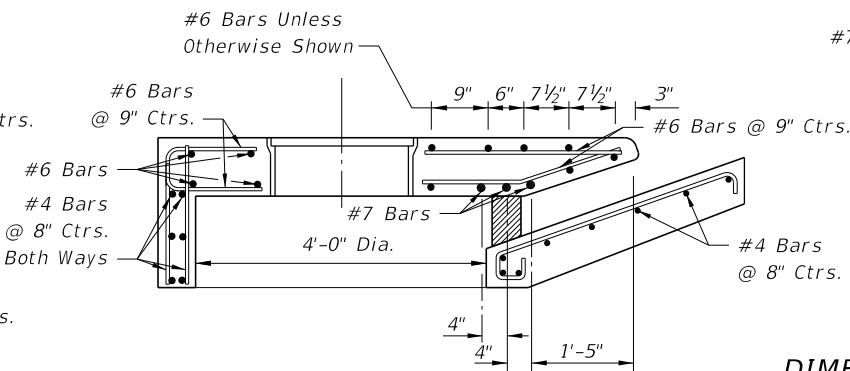

REINFORCING SECTION
4'-0" DIA. STRUCTURE BOTTOM (SECTION AA)

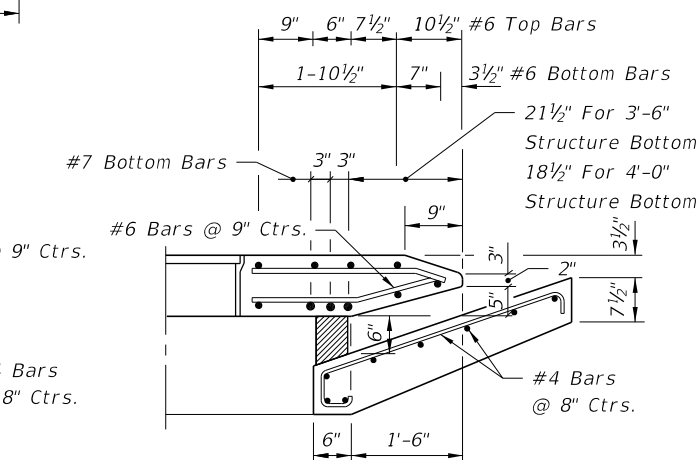

DIMENSION & REINFORCING HALF SECTION
TYPES A & E CURB (HALF SECTION AA)
(TYPE E GUTTER SHOWN)

GENERAL NOTES

- The finished grade and slope of the inlet tops are to conform with the finished cross slope and grade of the proposed sidewalk and/or border.
- When inlets are to be constructed on a curve, refer to the plans to determine the radius and, where necessary, modify the inlet details accordingly. Bend steel when necessary.
- All steel in inlet top shall have 1/4" minimum cover unless otherwise shown. Inlet tops shall be either cast-in-place or precast concrete.
- For precast units the rear wall and apron may be precast as a separate piece from the top slab. Provide a minimum of 7 ~ #4 dowels in accordance with Index No. 201 "OPTIONAL CONSTRUCTION JOINTS".
- For supplemental details see Index No. 201.
- Only round concrete support post will be acceptable.
- These inlets are designed for use with standard curb and gutter Types E and Type F. Locate inlet outside of pedestrian crosswalks.
- For structure bottoms see Index No. 200.
- Inlet to be paid for under the contract unit price for inlets (Curb) (Type_), Each.

TRANSVERSE SECTIONS FOR INLETS TYPES 1, 2, 3 & 4

LAST REVISION	DESCRIPTION:	 FDOT DESIGN STANDARDS FY 2012/2013	CURB INLET TOPS TYPES 1, 2, 3 AND 4	INDEX NO.	SHEET NO.
07/01/09				210	1

C:\projects\standards\roadway\0200-s\0210-01.dgn
 11:39:06 AM
 r1960/h
 12/30/2011