

NOTES

A. DESIGN SPECIFICATIONS:

1. AASHTO Standard Specifications for Highway Bridges (17th Edition).
2. AASHTO Guide Specifications for Structural Design of Sound Barriers (1989 Edition with 1992 and 2002 Interims).
3. FDOT Structures Manual (Current Edition).
4. Florida Department of Transportation's Plans Preparation Manual, Volume I (Current Edition).

B. DESIGN CRITERIA:

The Precast Sound Barriers are pre-designed and based on the criteria in the Structures Manual, Volume I.

C. CONCRETE AND GROUT:

1. Concrete Class and Compressive Strength:
 - a. Cast-in-Place Collars: Class IV ($f'c = 5500$ psi)
 - b. Precast Panels, Collars and Post Caps: Class IV ($f'c = 5500$ psi)
 - c. Posts: Class IV ($f'c = 5500$ psi)
2. Grout for Auger Cast Piling:
 - a. Maximum Working Compressive Strength = 2200 psi
 - b. Minimum 28 Day Strength = 5500 psi
3. Minimum Compressive Strength for Form Removal and Handling of Posts and Panels:
 - a. 2,500 psi for horizontally cast post and panels.
 - b. 2,000 psi for vertically cast panels or when tilt-up form tables are used for horizontally cast panels.

D. REINFORCING STEEL:

1. Reinforcing steel shall conform to ASTM A 615, Grade 60.
2. Welded wire reinforcement shall conform to ASTM A 185 (smooth wire) or ASTM A497 (deformed wire).
3. Concrete Cover of 2" shall be provided, unless otherwise noted.
4. In addition to the requirements of Specification Section 415, tie post and pile stirrups at the following locations as a minimum:
 - a. Post Stirrups - Tie at all four corner bars and at every third interior bar intersection.
 - b. Pile Stirrups - Tie to the main vertical reinforcing at alternate intersections for circular configurations and for rectangular configurations at the four corners and at every third interior bar intersection.

E. SURFACE FINISHES:

Provide a Class 5 Finish in accordance with Specification Section 400, unless otherwise shown on the Wall Control Drawings. See Sheet No. 2 for texture finish options.

F. PILING:

Construct Auger Cast Piling in accordance with the Plans and Specification Section 455.

G. UTILITIES:

Field verify the locations of all overhead and underground utilities shown in the Wall Control Drawings.

H. NEOPRENE PADS AND RESILIENT PADS:

1. Neoprene Pads for Panel Bearing Points Between the Stacked Panels:

The Neoprene pads for the panel bearing points shall be Plain Pads, Grade 50 durometer hardness in accordance with Specifications Sections 932-2.1.
2. Neoprene Pads for Collar Bearing Points:

Neoprene Pads shall be Fiber Reinforced Pads, with a durometer hardness between Grade 50 and Grade 80, in accordance with Specification Section 932-2.1. Plain Pads may be substituted for Fiber Reinforced Pads when sufficient bearing area is available on the concrete collar, as follows:

 - a. 10' post spacing: 4" x 4" x 1/2" Plain Pads, Grade 50 durometer hardness.
 - b. 20' post spacing and < 18' wall height: 4" x 4" x 1/2" Plain Pads, Grade 50 durometer hardness.
 - c. 20' post spacing and ≥ 18' wall height: 4" x 5" x 1/2" Plain Pads, Grade 50 durometer hardness.

J. CASTING TOLERANCES:

1. Overall Height & Width: +/- 1/4"
2. Thickness: +/- 1/4"
3. Plane of side mold: +/- 1/16"
4. Openings: +/- 1/2"
5. Out of Square: 1/8" per 6 ft., but not more than 3/8" total along any side
6. Warping: 1/16" per foot distance to nearest corner
7. Bowing: 1/240 panel dimension
8. Surface Smoothness for Type "A" (Smooth) Surface Texture Option: +/- 1/16" along a 10 ft. straightedge.

K. SOUND BARRIER WALL NOTES:

1. Distance between piles shall be a maximum of 20 ft. from centerline to centerline. These Sound Barrier Wall Standard Indexes allow for either 10 or 20 ft. post spacing. The panel system depicted is based on a 20 ft. post spacing.
2. Walls greater than 12 ft. in height shall consist of 2 or 3 stacked panels (upper and lower), each less than 12 ft. in height. The height of the upper panel shall be a minimum 8 ft. or greater as necessary to any graphic relief (if applicable). The lower panel(s) shall be not less than 4 ft. in height. Walls equal to or less than 12 ft. in height shall consist of either a single panel or 2 stacked panels with an 8 ft. upper panel provided that any graphic relief (if applicable) will fit within the upper panel.
3. Horizontal panel joints shall be located outside of the graphic relief (if applicable). Horizontal panel joints shall be held at a constant elevation for a given wall, where possible.
4. Posts shall be "H" type cross-section with panels installed from above.
5. All posts shall be held plumb in auger cast piles with an installation template. The template shall be adjustable for horizontal placement, vertical placement and plumbness of posts. The template shall be such that the installation tolerances can be held. Template shall remain in place for a minimum of 12 hours after post installation.
6. The Contractor shall be responsible for meeting OSHA requirements. Any utility adjustments, charges for power stoppages, all realignments, special erection methods, etc. to meet these requirements shall be included in bid.
7. Shimming of wall panels above the pile collar, beneath the bearing pads is permitted up to a maximum of 1 1/2" height. Shims must be either stainless steel (Type 304 or 316) or engineered polymer (copolymer or multipolymer) plastic. Plastic shims must have a minimum compressive strength of 8,000 psi without any fractures. Stacking of shims is permitted as follows:
 - a. For shimming height of 1" or less, provide up to 4 ~ 1/4" shims;
 - b. For shimming heights greater than 1", use a minimum 3/4" thick single shim and up to 3 ~ 1/4" shims. Stacked shim plates must be bonded together with a compatible epoxy adhesive.

L. CSIP OR CONTRACTOR REDESIGN:

1. In no case will CSIP (Cost Savings Initiative Proposal) or Contractor Redesigns be allowed to modify foundation designs, or post spacing.
2. Substitution of proprietary panels or systems not listed in the Wall Control Drawings will not be allowed.

M. QUALIFIED PRODUCTS LIST:

Manufacturers seeking approval of proprietary sound barrier panels, posts and foundations or systems for inclusion on the Qualified Products List as pre-approved suppliers must submit a QPL Product Evaluation Application along with design documentation, vendor drawings and other information as required in the Sound Barrier QPL Acceptance Criteria showing the proprietary product is designed to meet all specified requirements. Project specific Shop Drawings are required for sound barrier projects in accordance with Specification Section 534.

N. ALTERNATES:

The Contractor shall construct the standard precast 20'-0" panel option depicted in the plans or shall construct one of the proprietary sound barrier panel or proprietary system options (panel and foundation) listed in the Wall Control Drawings.

O. FINISH COATING:

All wall areas not shown to receive an anti-graffiti coating shall be coated in accordance with Specification Section 400 of the Specifications with a Class 5 Applied Finish Coating. The color of the system shall be same as the anti-graffiti system or as directed by the Engineer.

P. TEST WALL:

The Contractor shall construct a test wall at the beginning of the project consistent with Specification Section 534. The Contractor shall demonstrate that all casting and erection tolerances can be met in order to assure that the prefabricated elements fit together as intended.

REVISIONS

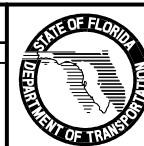

DATE	BY	DESCRIPTION	DATE	BY	DESCRIPTION
01/01/10	CMH	Changed Note K. 4. Added patent information to Note K. 5.	01/01/11	CMH	Changed Title and Sheet No. to 1 of 15; Notes E, K, & O to remove foundation and post "Options"; Note L from VECP to CSIP, and Note B from PPM to SDG.
07/01/10	CMH	Changed Note B and Note H.2.			



2010 Interim Design Standard

PRECAST SOUND BARRIERS - GENERAL NOTES

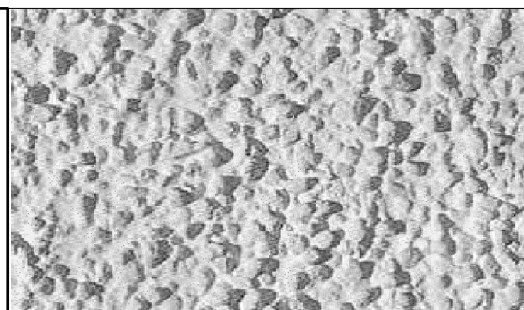
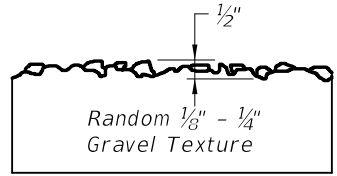
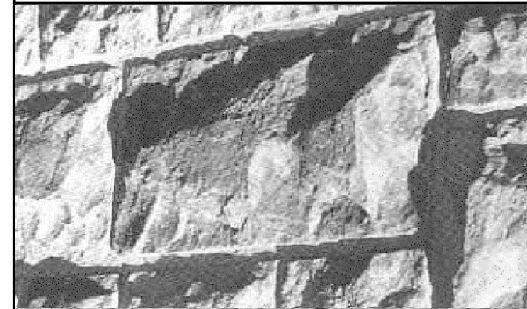
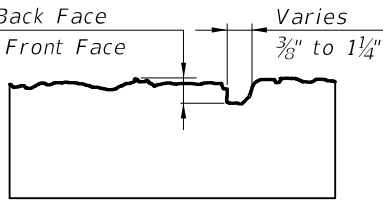
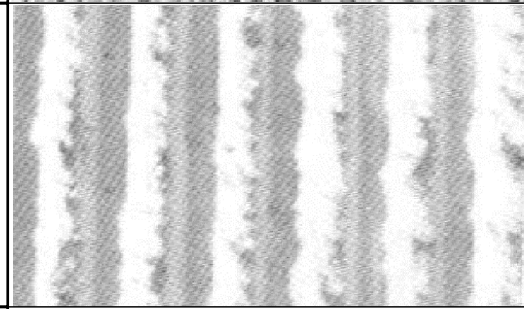
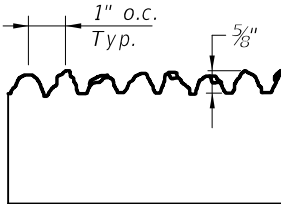
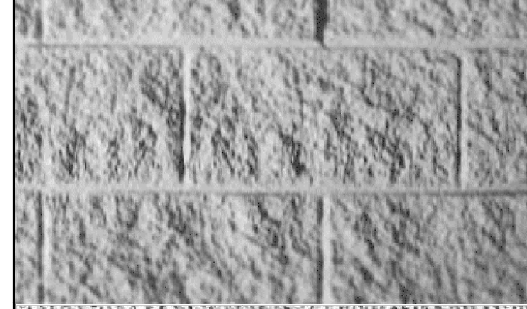
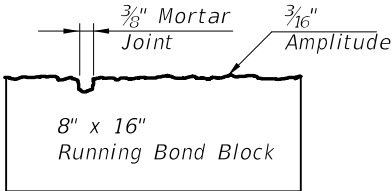
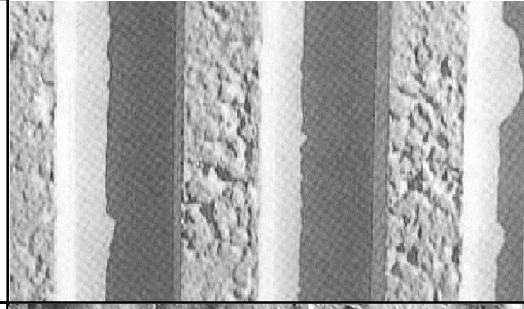
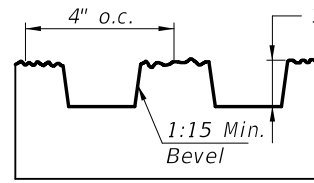
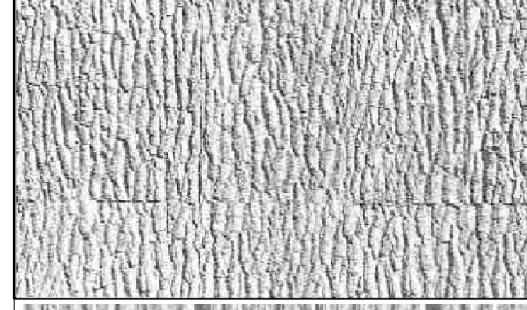
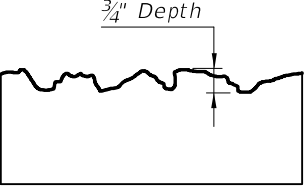
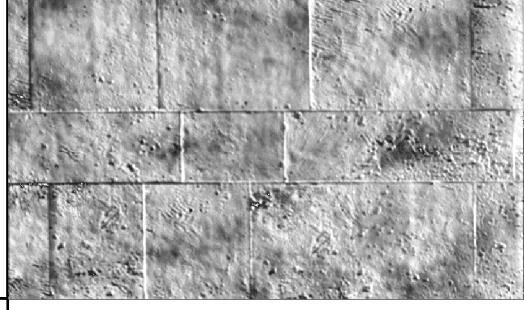
Interim Date	Sheet No.
01/01/11	1 of 15
Index No.	
5200	

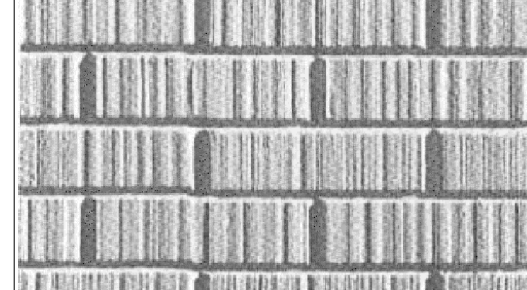
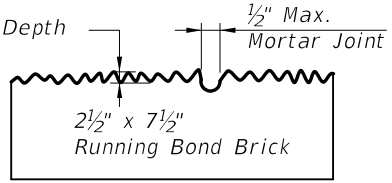
	<p>Type "A" SMOOTH</p>		<p>Type "F" PEA GRAVEL</p> 								
	<p>Type "B" ASHLAR STONE</p> 		<p>Type "G" VERTICAL FRACTURED FIN</p> 								
	<p>Type "C" SPLIT FACE RUNNING BOND BLOCK</p> 		<p>Type "H" TRAPEZOID VERTICAL FINNS W/ FRACTURED FACE (COLORADO DRAG AGGREGATE)</p> 								
	<p>Type "D" FRACTURED GRANITE</p> 		<p>Type "I" CUT CORAL BLOCK (RUNNING BOND)</p>  <p>Running Bond Block:</p> <table border="1" data-bbox="2209 1272 2666 1378"> <tr> <td>12" x (12", 14", 16" & 12")</td> <td>(1st course)</td> </tr> <tr> <td>6" x (21", 10" & 23")</td> <td>(2nd course)</td> </tr> <tr> <td>12" x (9", 10", 21" & 14")</td> <td>(3rd course)</td> </tr> <tr> <td>6" x (16", 14" & 24")</td> <td>(4th course)</td> </tr> </table>	12" x (12", 14", 16" & 12")	(1st course)	6" x (21", 10" & 23")	(2nd course)	12" x (9", 10", 21" & 14")	(3rd course)	6" x (16", 14" & 24")	(4th course)
12" x (12", 14", 16" & 12")	(1st course)										
6" x (21", 10" & 23")	(2nd course)										
12" x (9", 10", 21" & 14")	(3rd course)										
6" x (16", 14" & 24")	(4th course)										
	<p>Type "E" WIRE-CUT BRICK</p> 	<p>NOTES:</p> <ol style="list-style-type: none"> Surfaces shall be formed, rolled, or pressed using form liners in accordance with the Plans and Specifications (Class 3 Surface Finish). See Wall Control Drawings for project aesthetic requirements. 									

TEXTURE OPTIONS

REVISIONS			
DATE	BY	DESCRIPTION	
01/01/11	CMH	New Sheet from Index No. 5201.	

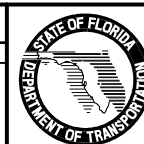

2010 Interim Design Standard

PRECAST SOUND BARRIERS

Interim Date	Sheet No.
01/01/11	2 of 15
Index No.	
5200	

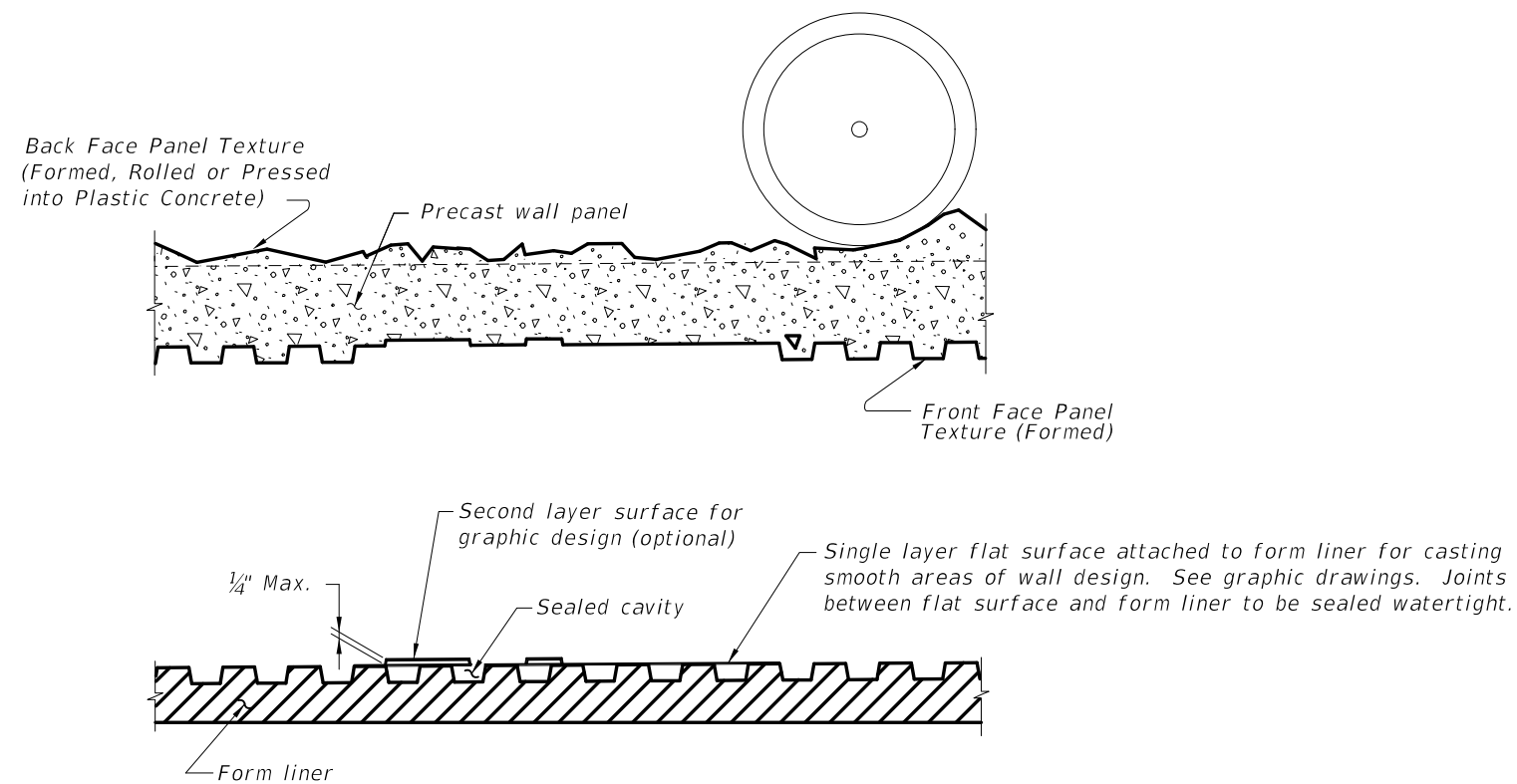
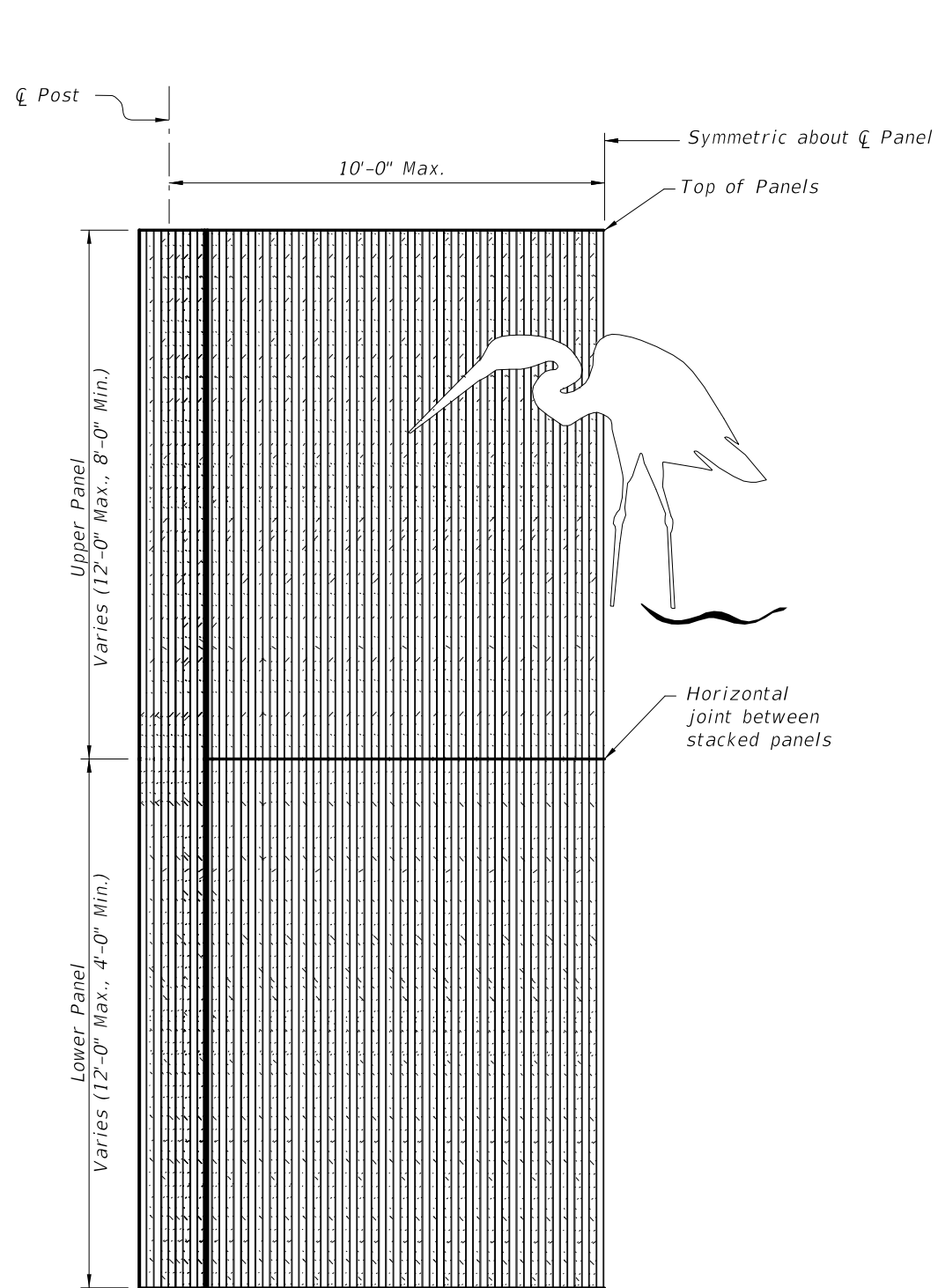

TYPICAL FORMING DETAIL
 (Front Face Panel Texture Type "H" shown)
 (Back Face Panel Texture Type "D" shown)

NOTES:

1. Contractor shall submit specific form liner samples for approval by the Engineer.
2. Textures and graphics shown are for demonstration purposes only. See Wall Control Drawings for project specific texture and graphic requirements.

HALF ELEVATION
 (Front Face Panel Texture Type "H" and Front Face Post Texture Type "H" Shown.)
 (Graphic Type SE-2 Shown.)
 (Two stacked panels shown, 3 stacked panels similar)

REVISIONS					
DATE	BY	DESCRIPTION	DATE	BY	DESCRIPTION
01/01/11	CMH	New Sheet from Index No. 5202 (Sheet 6 of 6).			

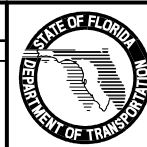

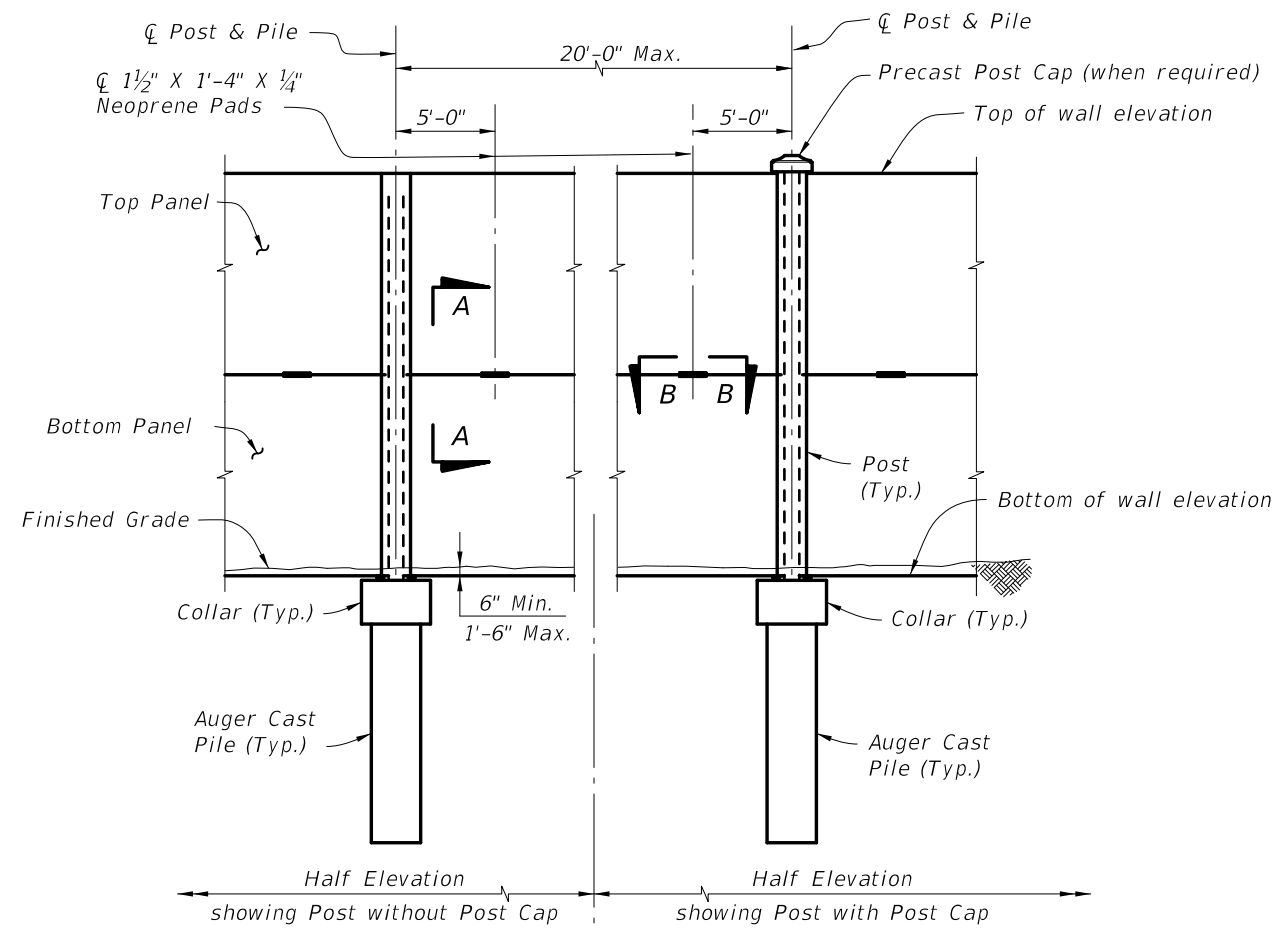

TYPICAL ELEVATION

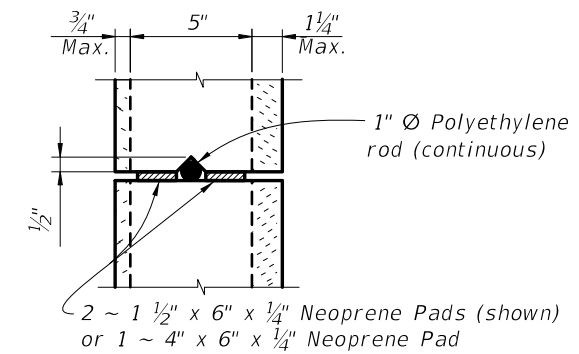

SECTION A-A

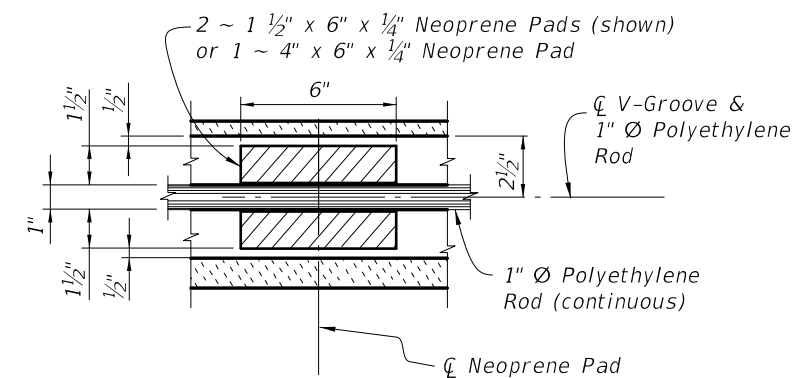

SECTION B-B

TYPICAL DETAILS

REVISIONS					
DATE	BY	DESCRIPTION	DATE	BY	DESCRIPTION
01/01/11	CMH	New Sheet. TYPICAL ELEVATION, SECTION A-A & SECTION B-B copied from 5202-1of6.			

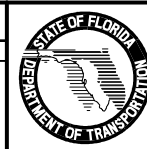

2010 Interim Design Standard

PRECAST SOUND BARRIERS

Interim Date	Sheet No.
01/01/11	4 of 15
Index No.	
5200	

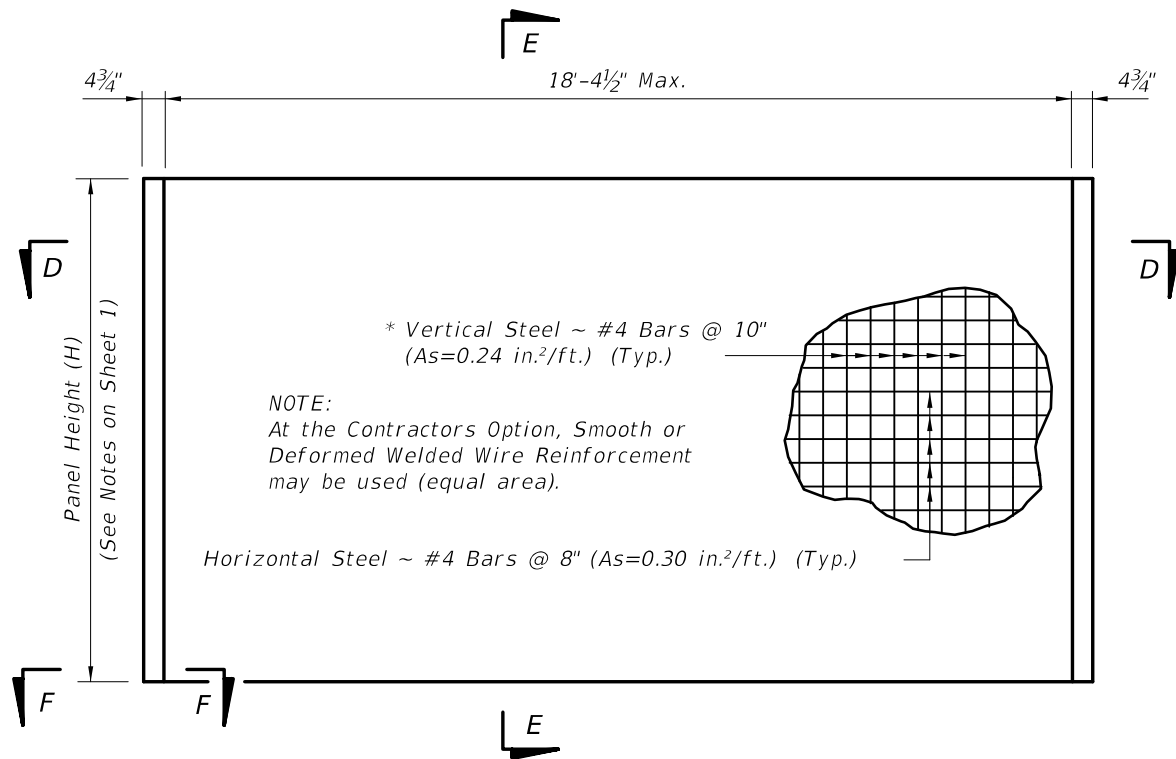

TYPICAL PANEL ELEVATION

* In lieu of utilizing the pick up points below, panels may be cast vertically or cast horizontally then tilted upright using tilt-tables prior to lifting from form. In this case, the vertical steel may be reduced to #4 Bars @ 1'-3" (As=0.15 in.²/ft.).

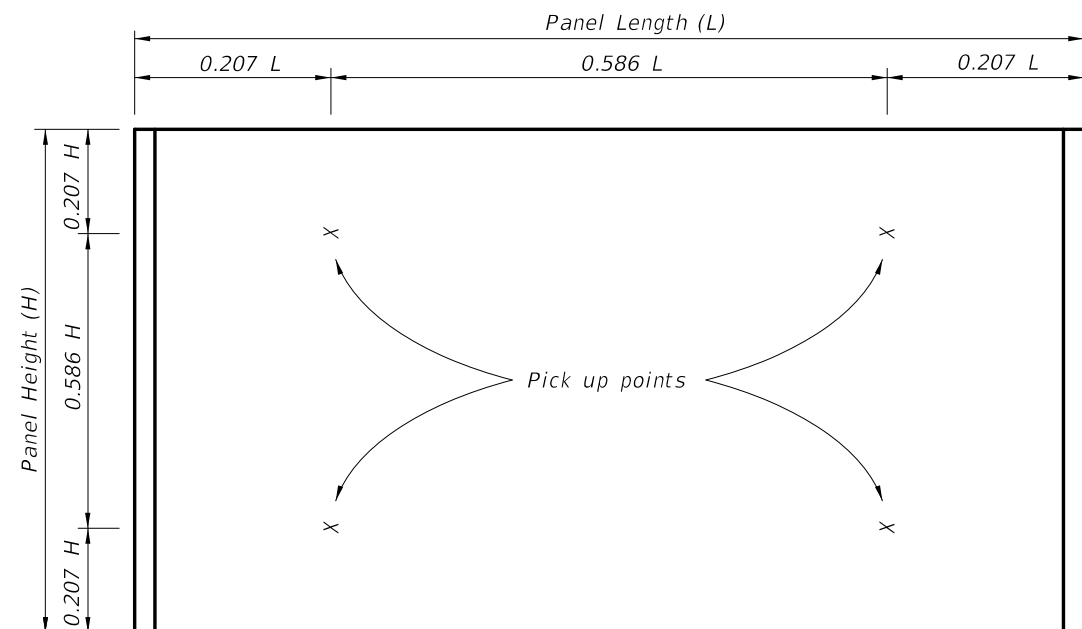

REQUIRED PICK UP POINTS FOR PANELS
(Panels shall be rotated about long axis only)

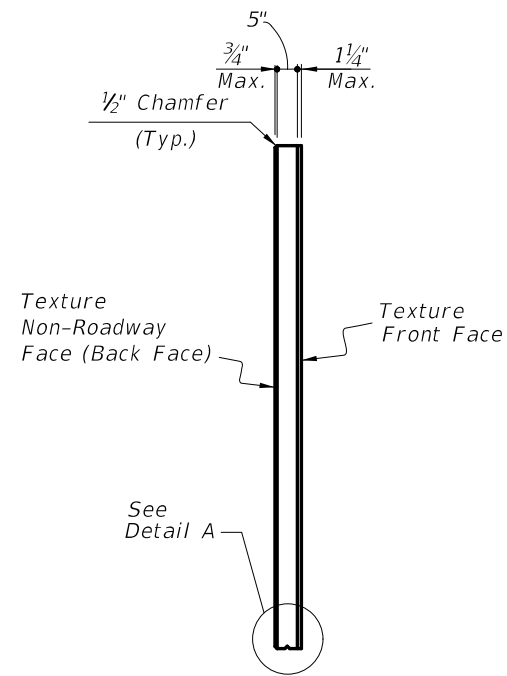

SECTION E-E

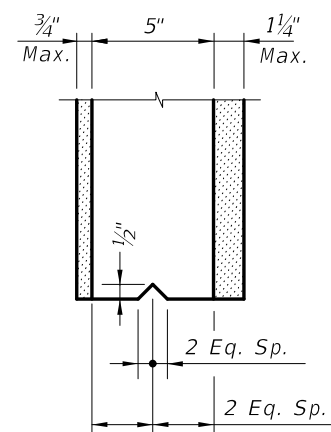

DETAIL A

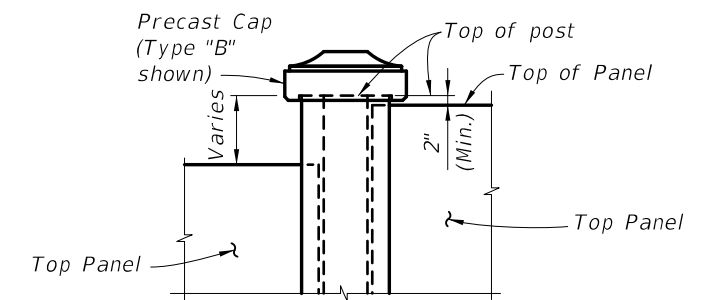

PRECAST POST CAP DETAIL

NOTE: See plans for Post Cap requirements.
See Sheet 13 for Post Cap details.

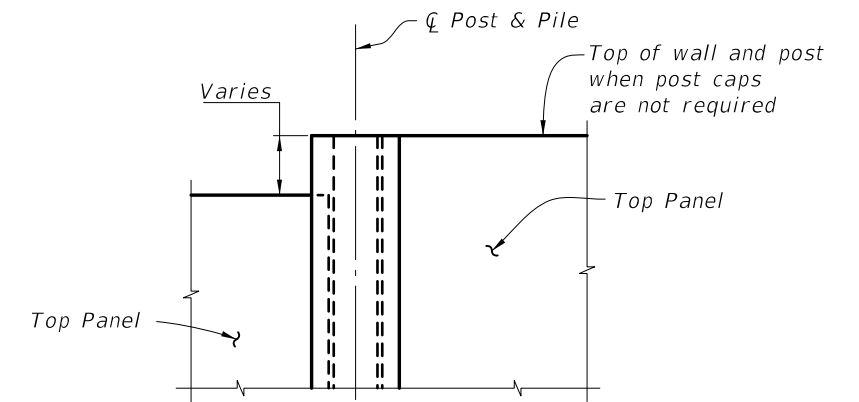

ELEVATION STEP AT TOP OF WALL

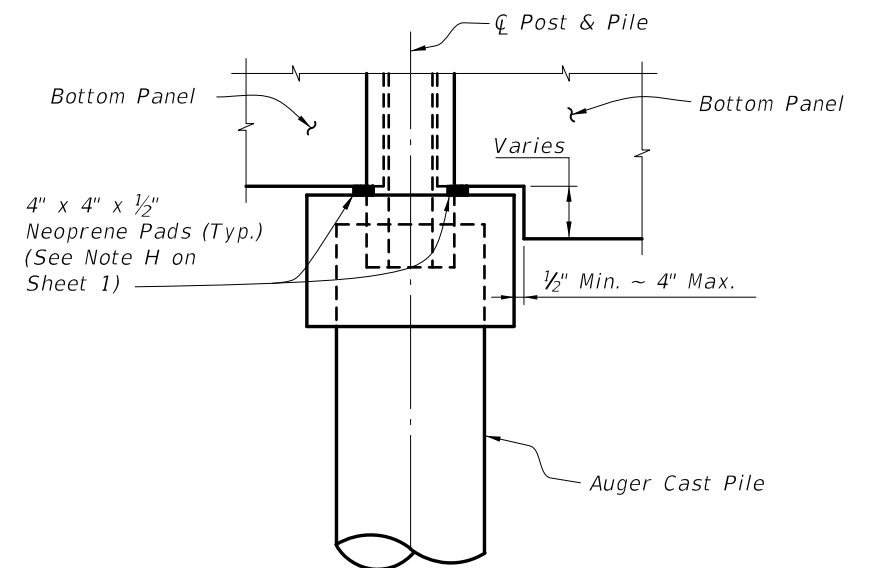

ELEVATION STEP AT BOTTOM OF WALL

TYPICAL PANEL DETAILS

REVISIONS

DATE	BY	DESCRIPTION	DATE	BY	DESCRIPTION
01/01/11	CMH	New Sheet. TYPICAL PANEL ELEVATION, REQUIRED PICK UP POINTS FOR PANELS, SECTION E-E & DETAIL A copied from 5202-2of6.	01/01/11	CMH	PRECAST POST CAP DETAIL, ELEVATION STEP AT TOP OF WALL & ELEVATION STEP AT BOTTOM OF WALL copied from 5202-1of6.

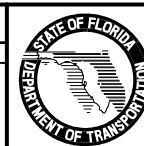

2010 Interim Design Standard

PRECAST SOUND BARRIERS

Interim Date 01/01/11
Sheet No. 5 of 15

Index No.
5200

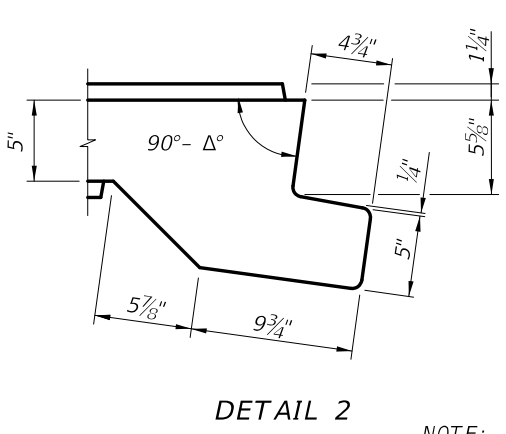
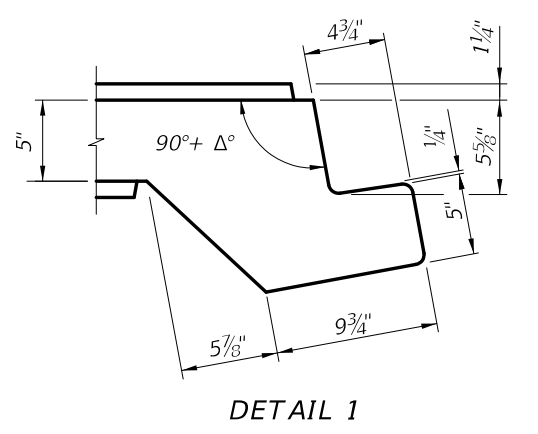
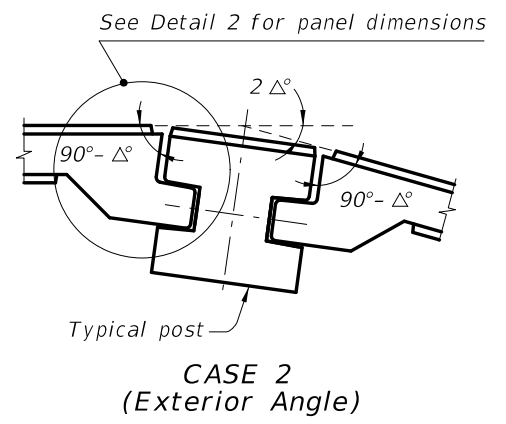
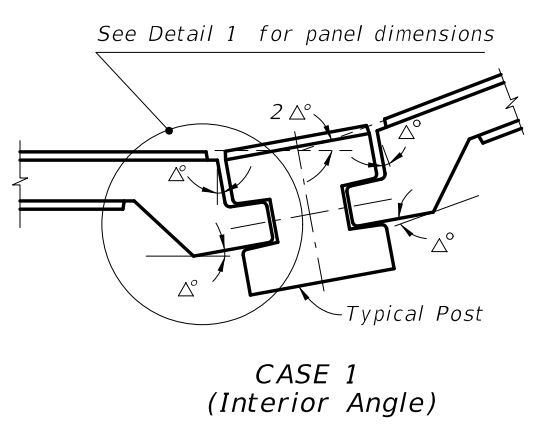
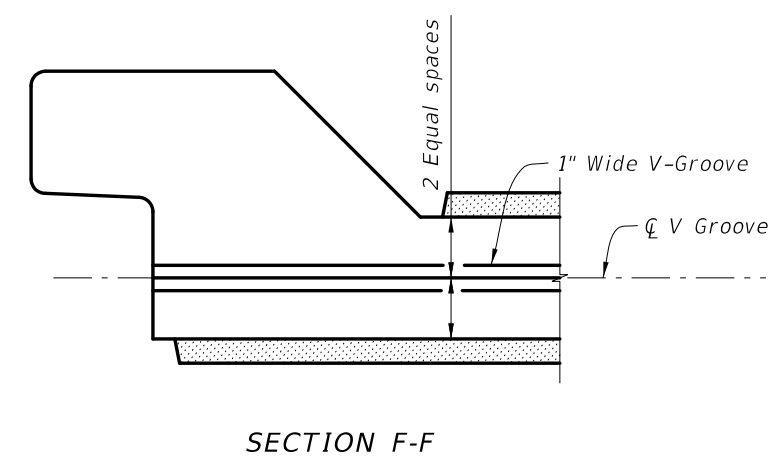
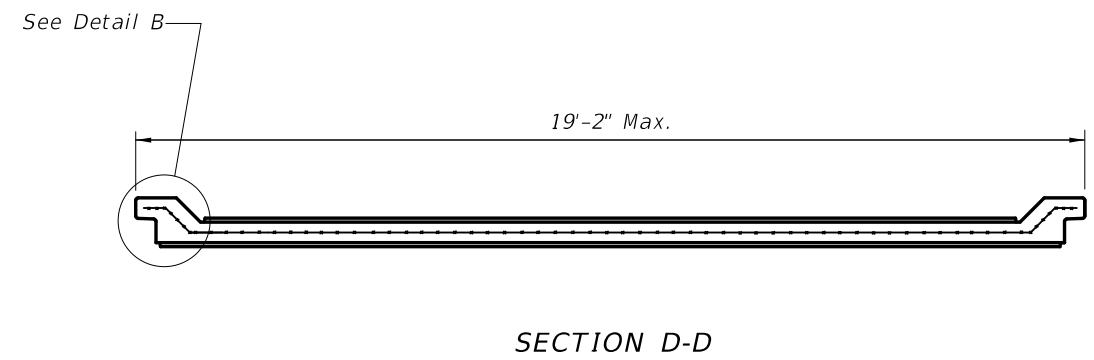
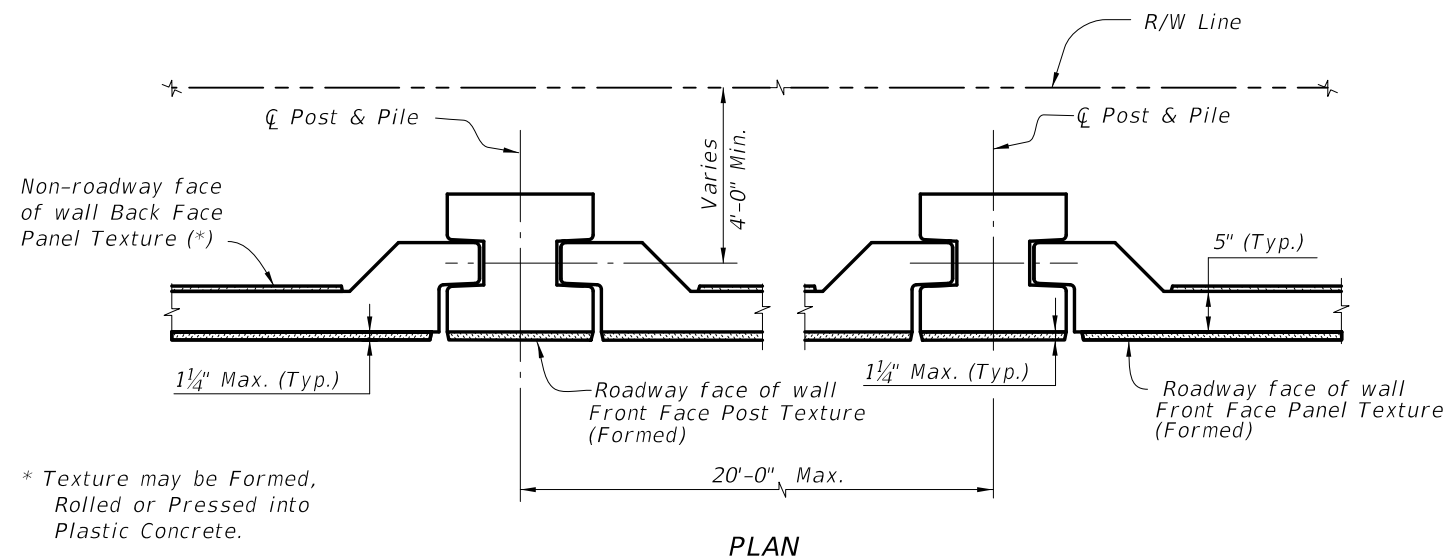

PIVOTING POINT DETAILS

NOTE: The shop drawings shall include specific pivoting point details of panel ends at locations where the deflection angle (2Δ) between panels exceeds 7° .

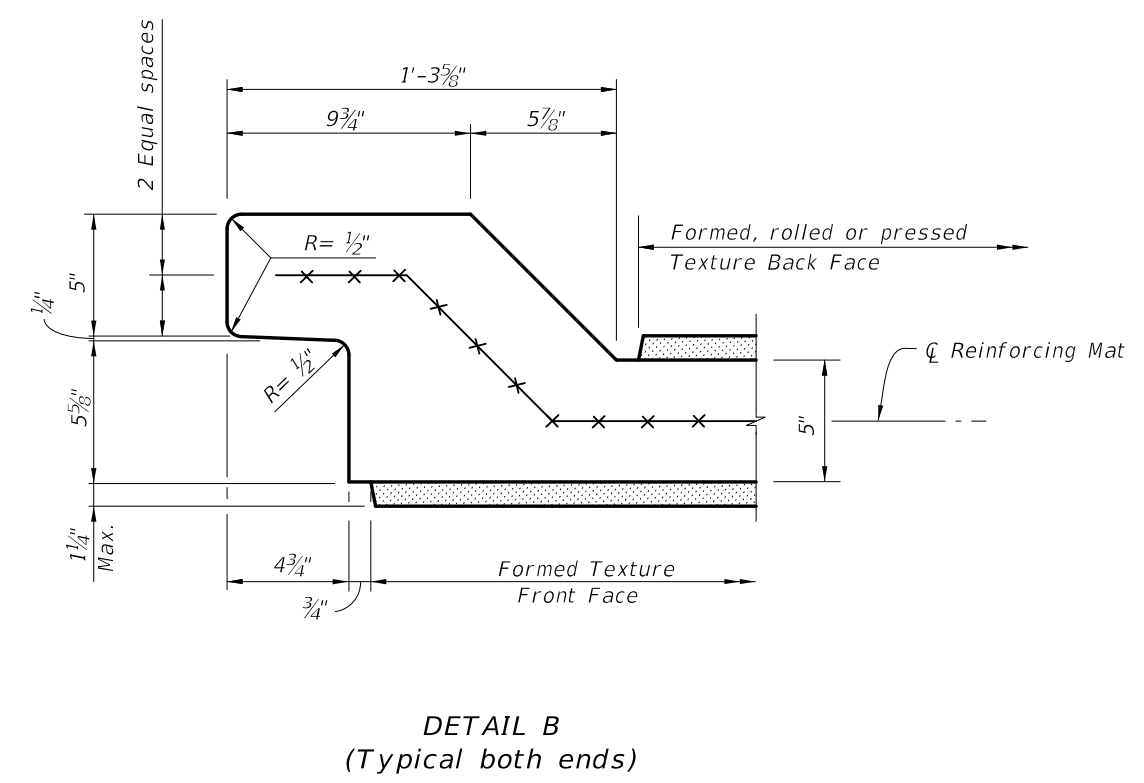

FLUSH PANEL END DETAILS

REVISIONS			
DATE	BY	DESCRIPTION	
01/01/11	CMH	New Sheet. PLAN copied from 5202-1of6. PIVOTING POINT DETAILS copied from 5202-3of6. SECTION D-D, SECTION F-F & DETAIL B copied from 5202-2of6.	

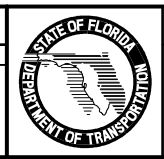

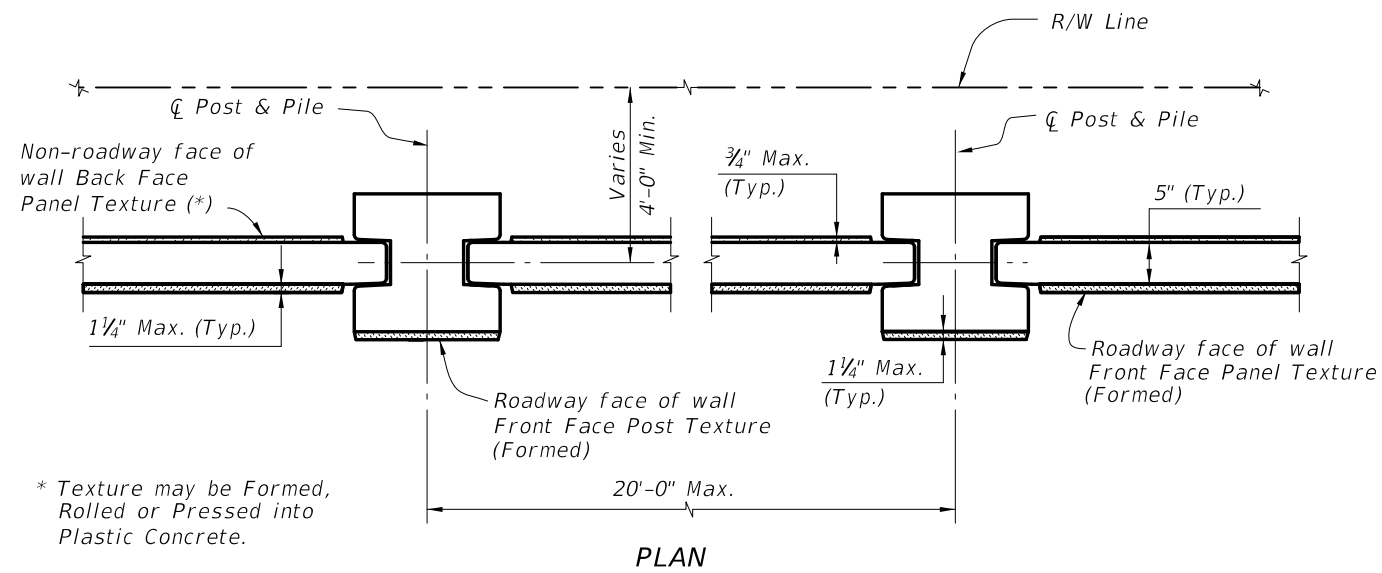

* Texture may be Formed, Rolled or Pressed into Plastic Concrete.

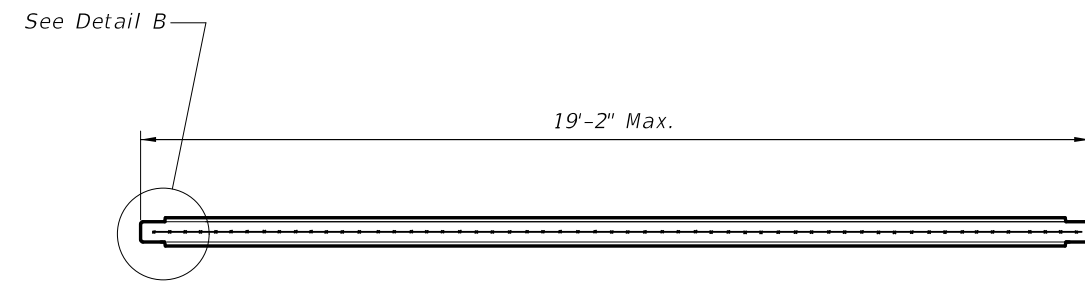

SECTION D-D

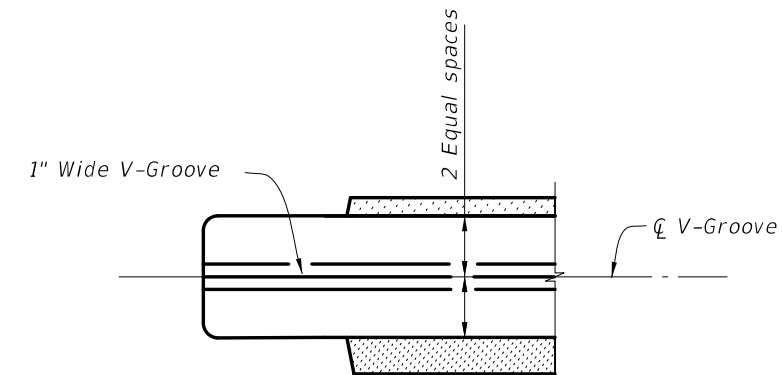

SECTION F-F

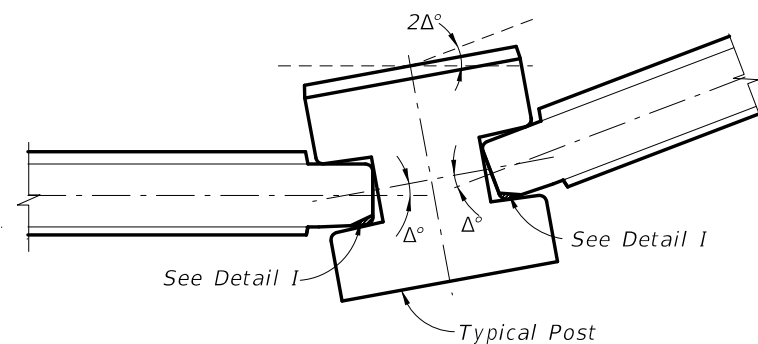

CASE 1
(Interior Angle)

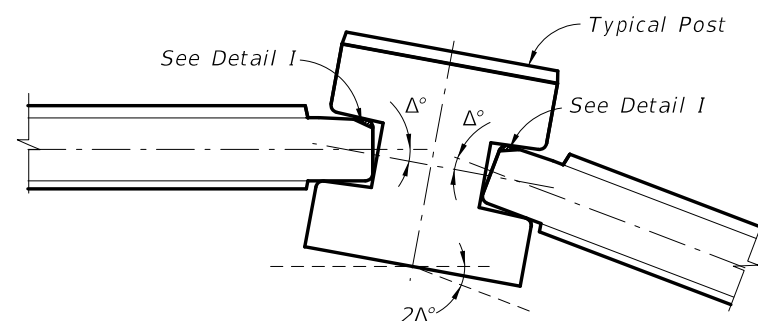

CASE 2
(Exterior Angle)

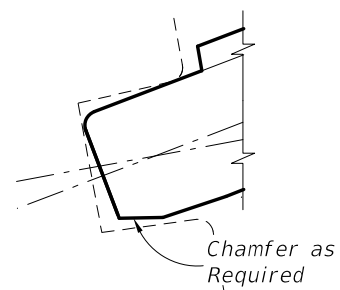

DETAIL I
(Back Face Chamfer Shown
Front Face Chamfer Similar)

NOTE:
The shop drawings shall include specific pivoting point details of panel ends at locations where the deflection angle ($2\Delta^\circ$) between panels exceeds 20° .

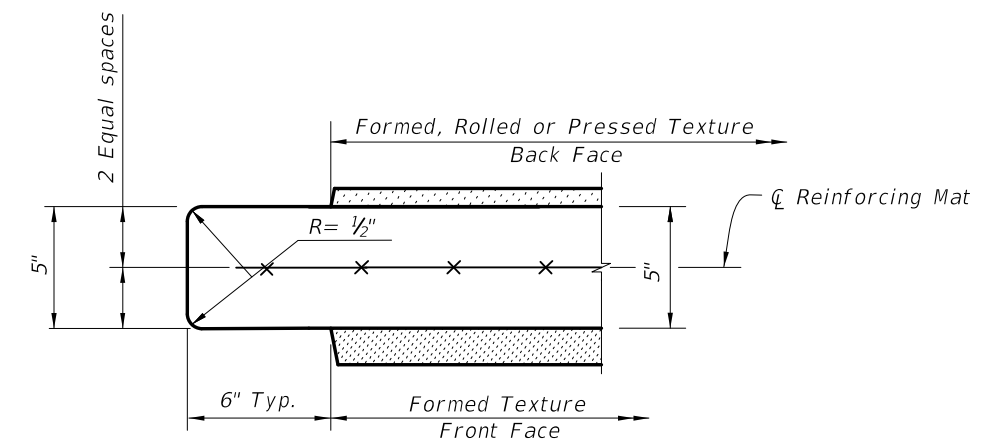

DETAIL B
(Typical both ends)

PIVOTING POINT DETAILS

RECESSED PANEL END DETAILS

REVISIONS

DATE	BY	DESCRIPTION	DATE	BY	DESCRIPTION
01/01/11	CMH	New Sheet. PLAN copied from 5203-1of6. SECTION D-D, SECTION F-F & DETAIL B copied from 5203-2of6. PIVOTING POINT DETAILS copied from 5203-3of6.			

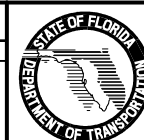

2010 Interim Design Standard

PRECAST SOUND BARRIERS

Interim Date 01/01/11 Sheet No. 7 of 15

Index No. 5200

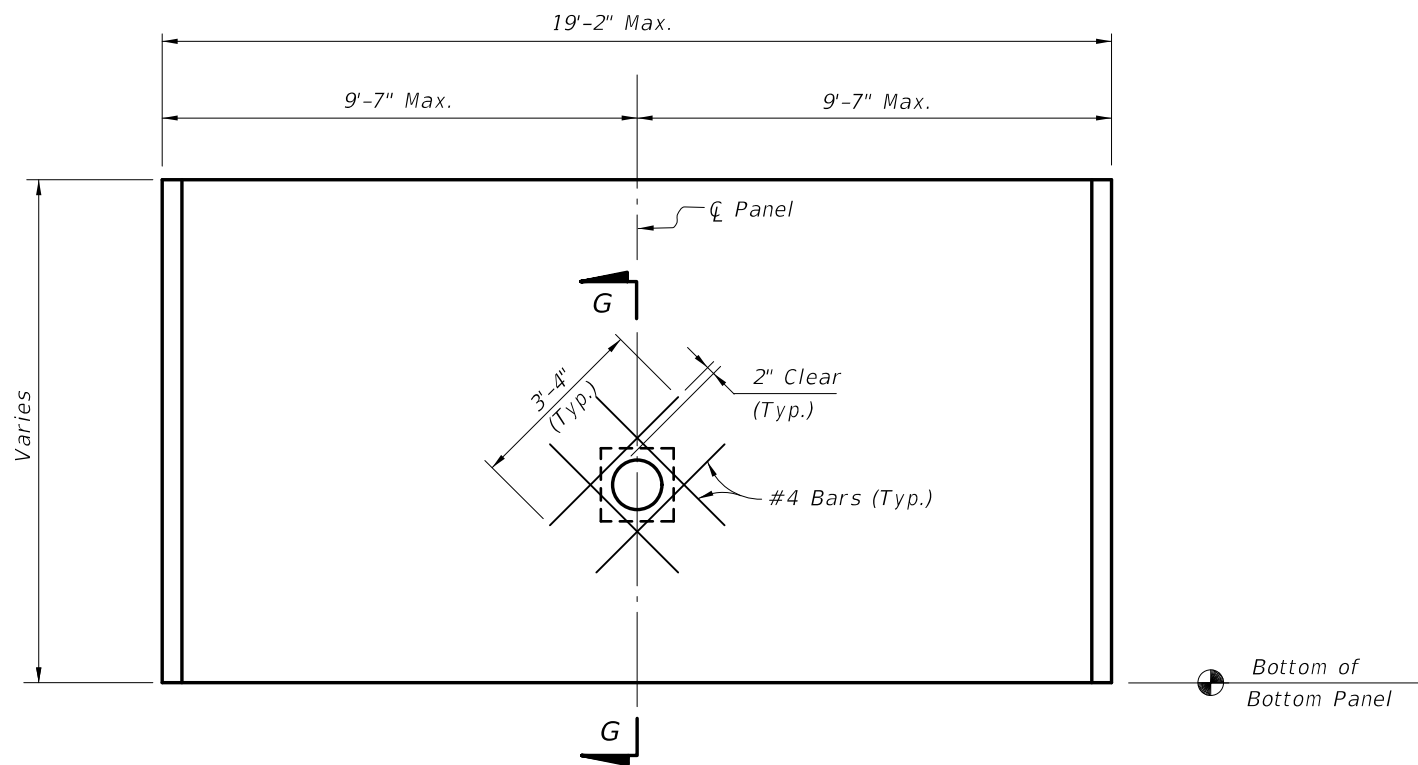

FIRE HOSE ACCESS HOLE TYPICAL DETAIL
 (Front Face of Wall Shown)
 (Flush Panel Option Shown)
 Recessed Panel Option Similar)

NOTE: Fire Hose Access Point to be located at or near fire hydrants

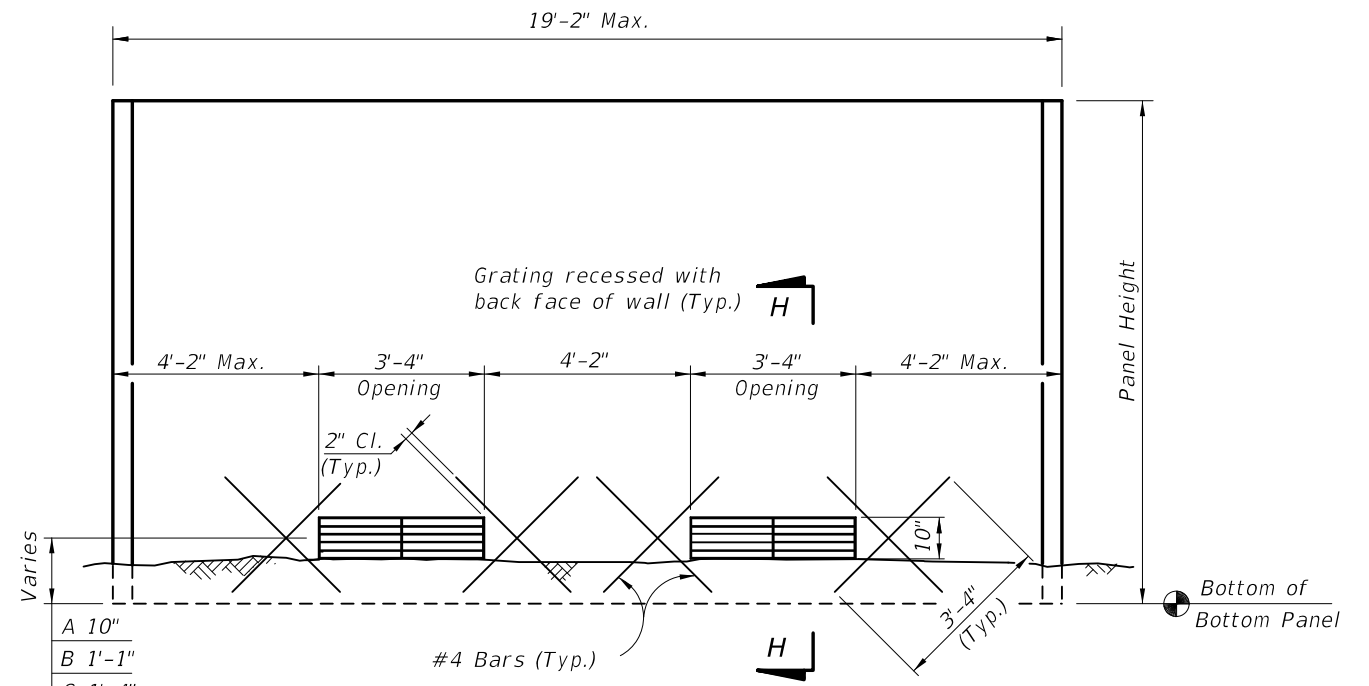

DRAINAGE HOLES TYPES A, B, C & D
 (Front Face of Wall Shown)
 (Flush Panel Option Shown)
 Recessed Panel Option Similar)

NOTE: Hole Types A, B, C and D refer to distance from bottom of panel to center of opening. See Wall Control Drawings.

- A 10"
- B 1'-1"
- C 1'-4"
- D 2'-8"

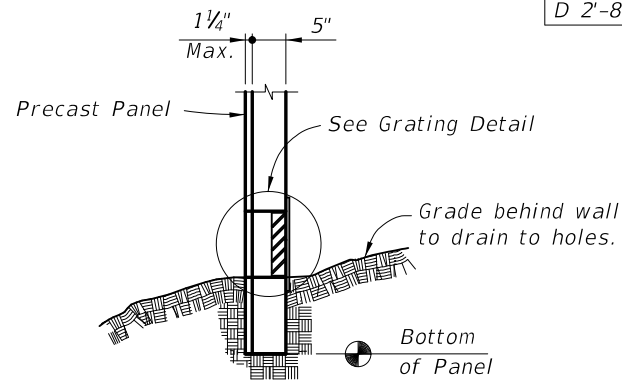

SECTION H-H
 (Flush Panel Option Shown)
 Recessed Panel Option Similar)

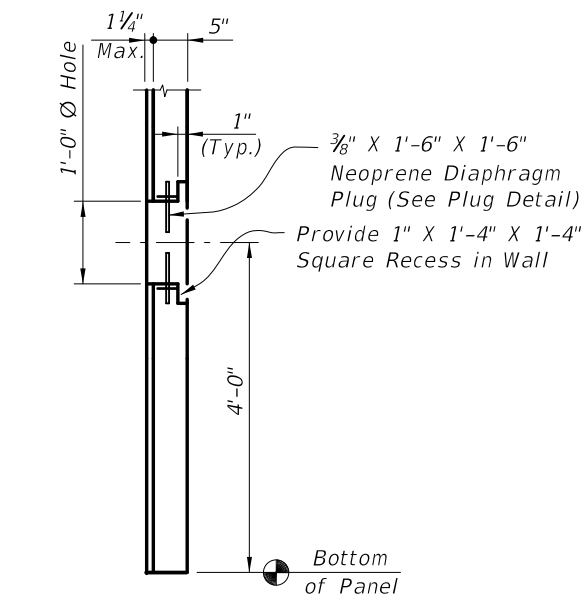

SECTION G-G
 (Flush Panel Option Shown)
 Recessed Panel Option Similar)

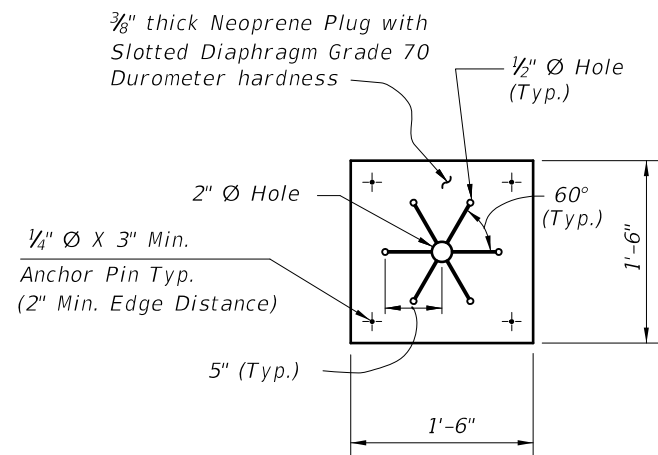

PLUG DETAIL

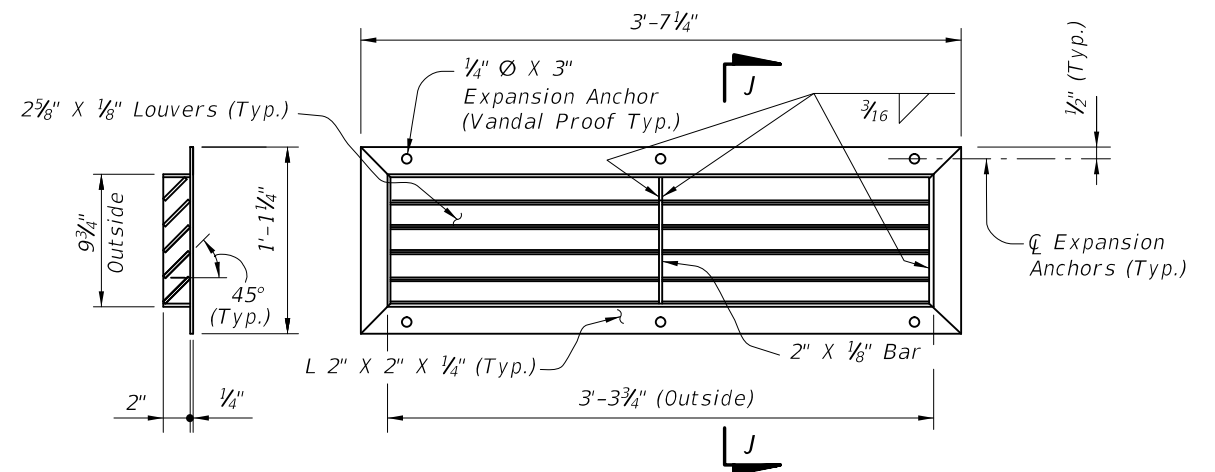

SECTION J-J

GRATING DETAIL

NOTES:
 Grating shall be ASTM A 36 steel and shall be hot dip galvanized after assembly in accordance with ASTM Specification A 123.
 Expansion anchors shall be in accordance with ASTM A 307 (Galvanized).
 Welding shall be in accordance with the current edition of the ANSI/AWS D1.1 Welding Code.

FIRE HOSE ACCESS HOLE & DRAINAGE DETAILS

REVISIONS

DATE	BY	DESCRIPTION	DATE	BY	DESCRIPTION
01/01/11	CMH	New Sheet from Index No. 5204 (Sheet 1 of 1).			

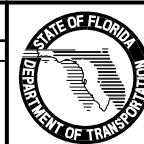

2010 Interim Design Standard

PRECAST SOUND BARRIERS

Interim Date	Sheet No.
01/01/11	8 of 15
Index No.	
5200	

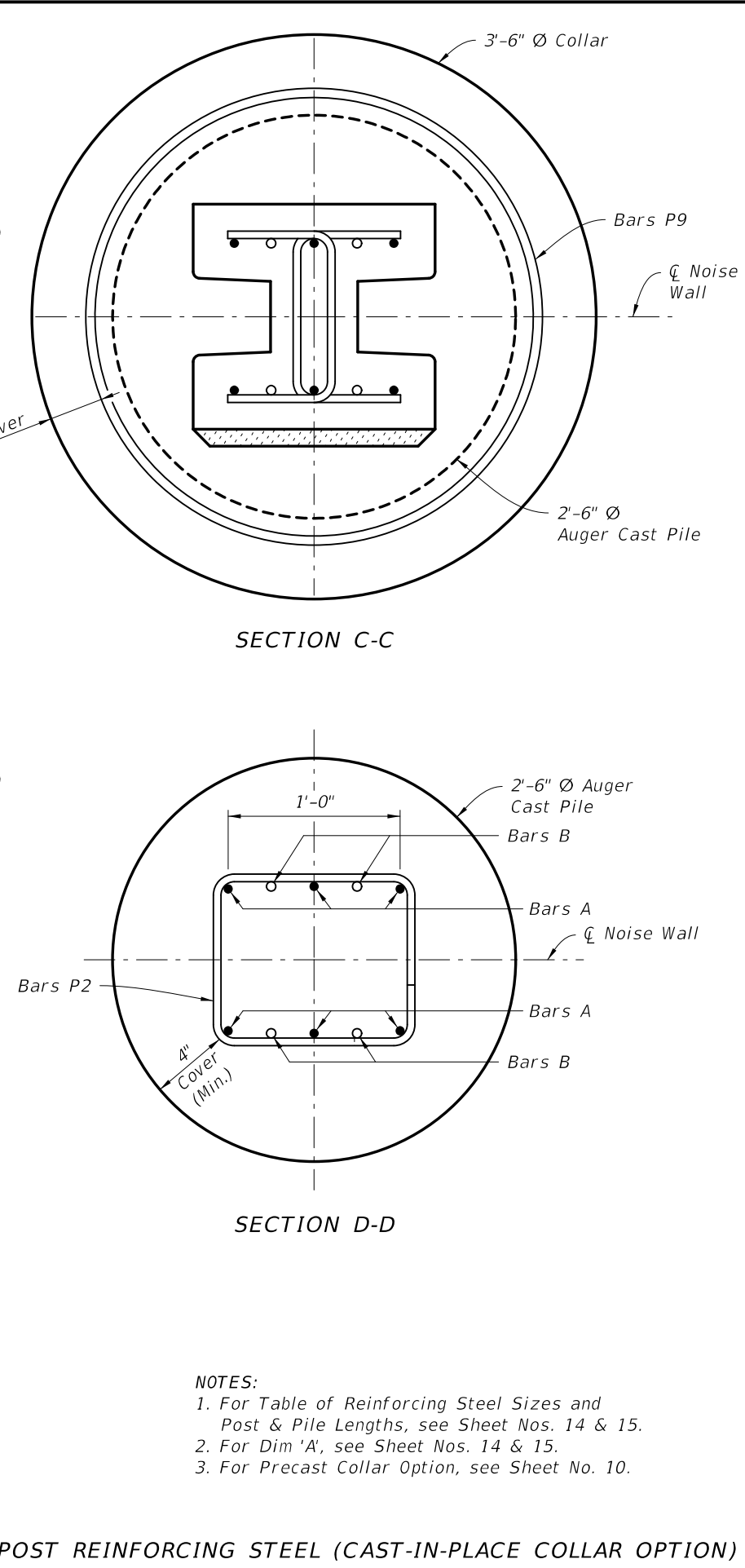
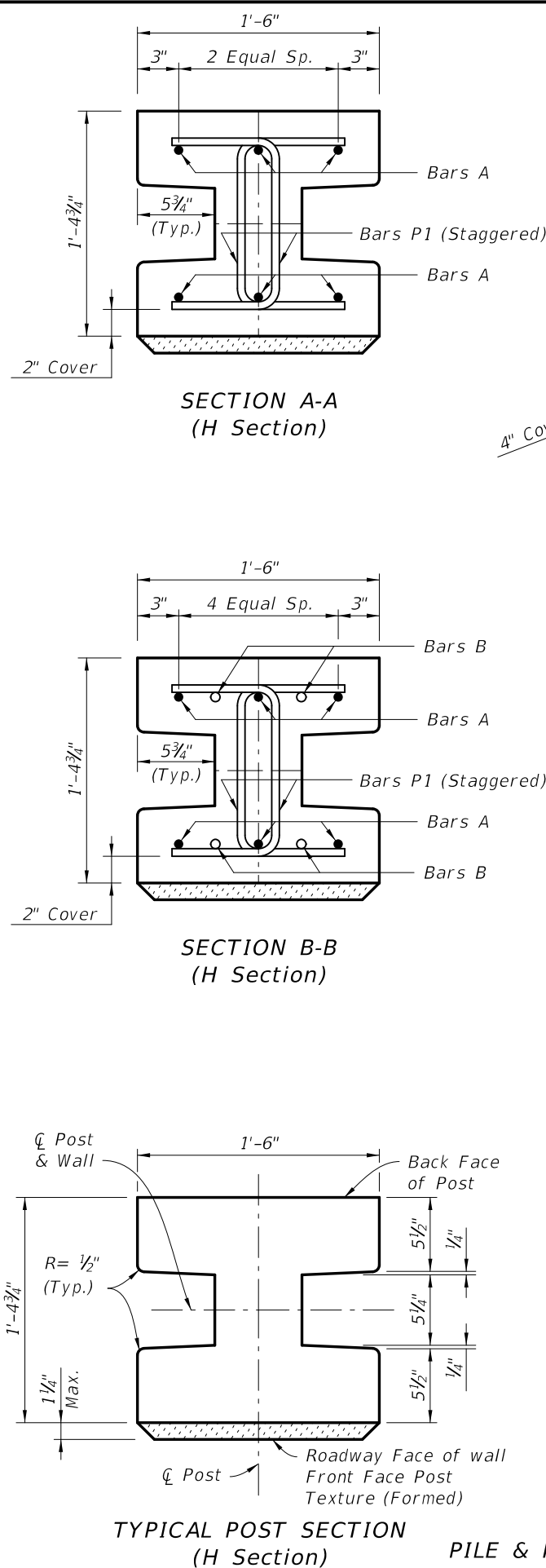
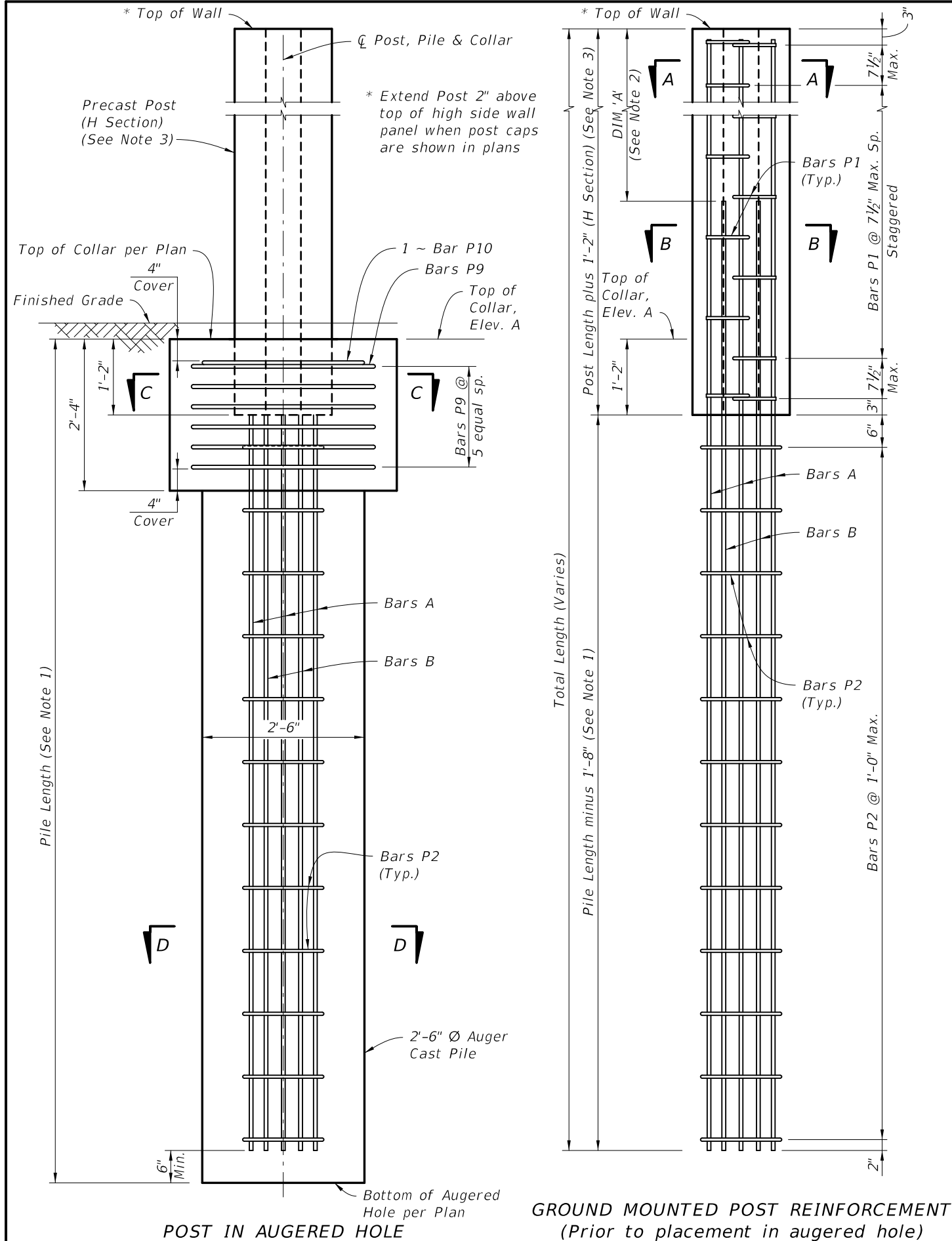

- NOTES:**
1. For Table of Reinforcing Steel Sizes and Post & Pile Lengths, see Sheet Nos. 14 & 15.
 2. For Dim 'A', see Sheet Nos. 14 & 15.
 3. For Precast Collar Option, see Sheet No. 10.

GROUND MOUNTED POST REINFORCEMENT
(Prior to placement in augered hole)

TYPICAL POST SECTION
(H Section)

PILE & POST REINFORCING STEEL (CAST-IN-PLACE COLLAR OPTION)

REVISIONS			
DATE	BY	DESCRIPTION	
01/01/11	CMH	New Sheet from Index No. 5205 (Sheet 6 of 7). Redrawn to scale, revised.	

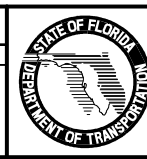

2010 Interim Design Standard

PRECAST SOUND BARRIERS

Interim Date	Sheet No.
01/01/11	9 of 15
Index No.	
5200	

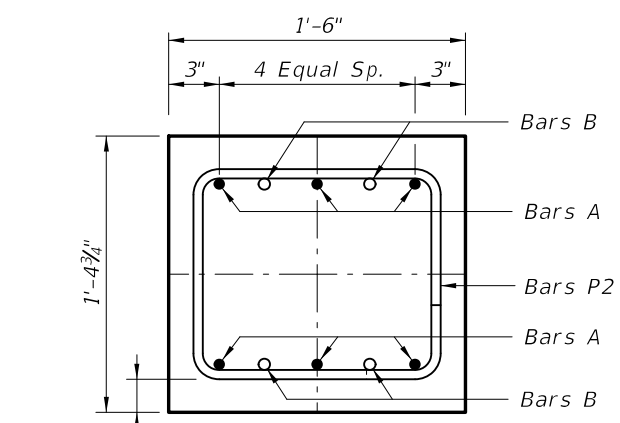
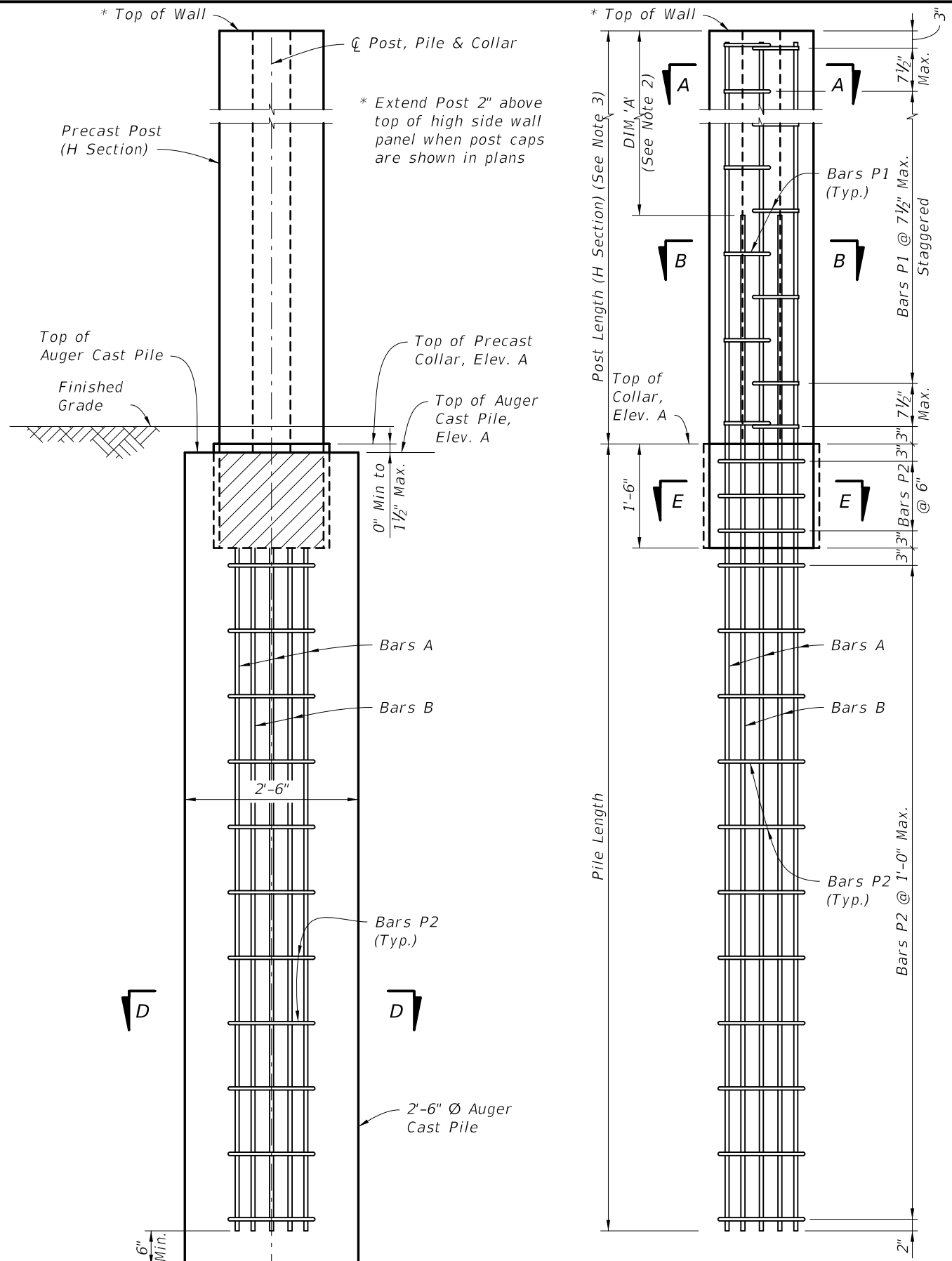

SECTION E-E
(Rectangular Precast Collar)

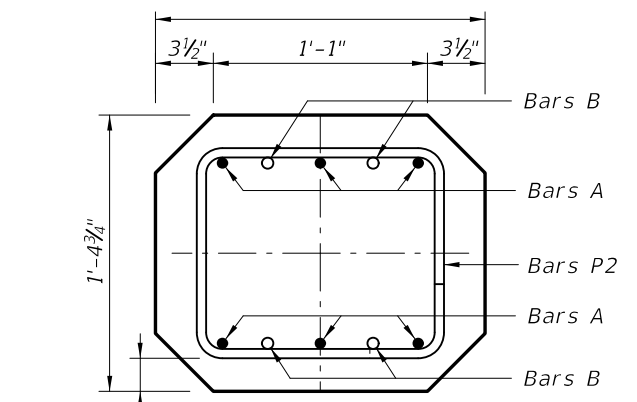

SECTION E-E
(Octagonal Precast Collar)

- NOTES:
1. For Table of Reinforcing Steel Sizes and Post & Pile Lengths, see Sheet Nos. 14 & 15.
 2. For Dim 'A', see Sheet Nos. 14 & 15.
 3. For Sections A-A, B-B & D-D see Sheet No. 9.

PRECAST COLLAR IN AUGER CAST PILE
GROUND MOUNTED POST REINFORCEMENT
(Prior to placement in augered hole)

PILE & POST REINFORCING STEEL (PRECAST COLLAR OPTION)

REVISIONS			
DATE	BY	DESCRIPTION	
01/01/11	CMH	New Sheet from Index No. 5205 (Sheet No. 7 of 7).	

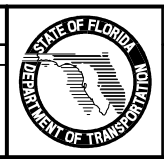

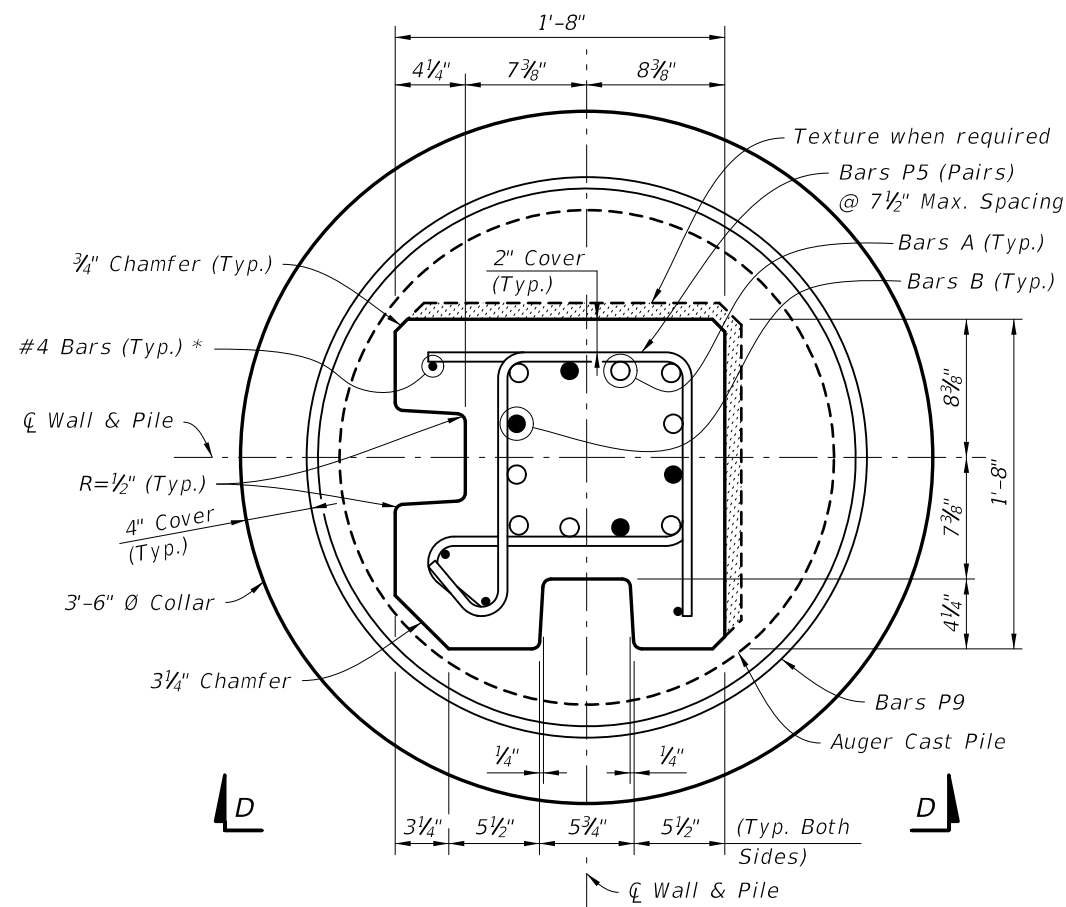

SECTION A-A
TYPICAL SECTION ABOVE PILE

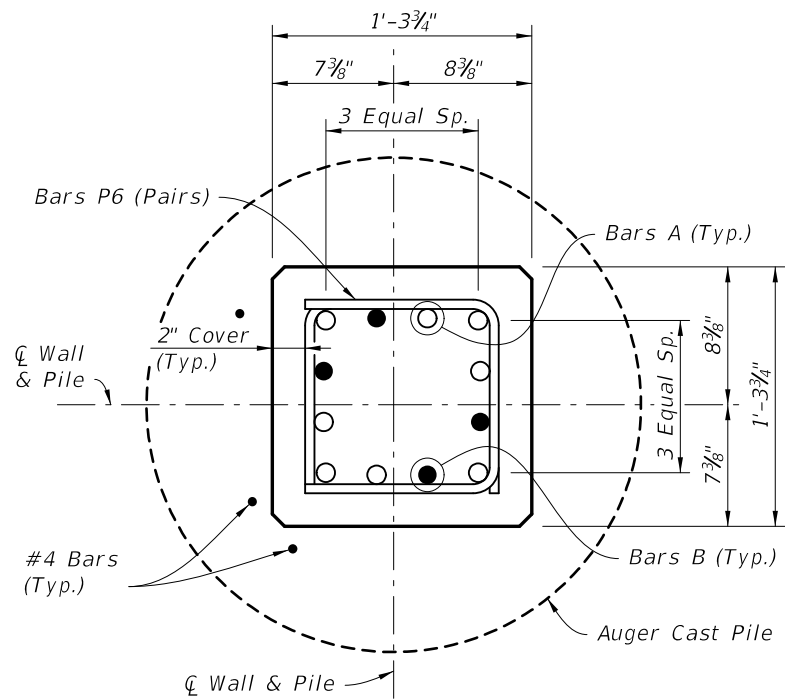

SECTION B-B
(Modified Base Section)

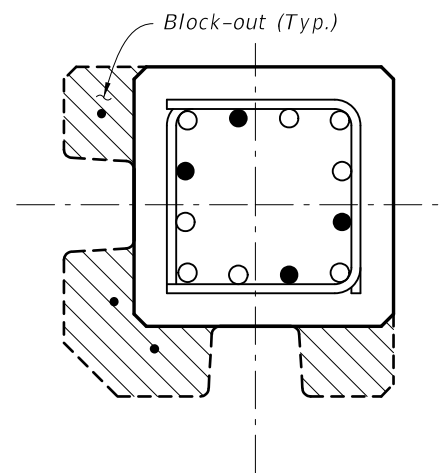

SECTION C-C
(Showing 1'-0" Block-out)

* Block-out with #4 Bars terminating @ 1'-2" to 1'-6" below top of collar (Typ.)

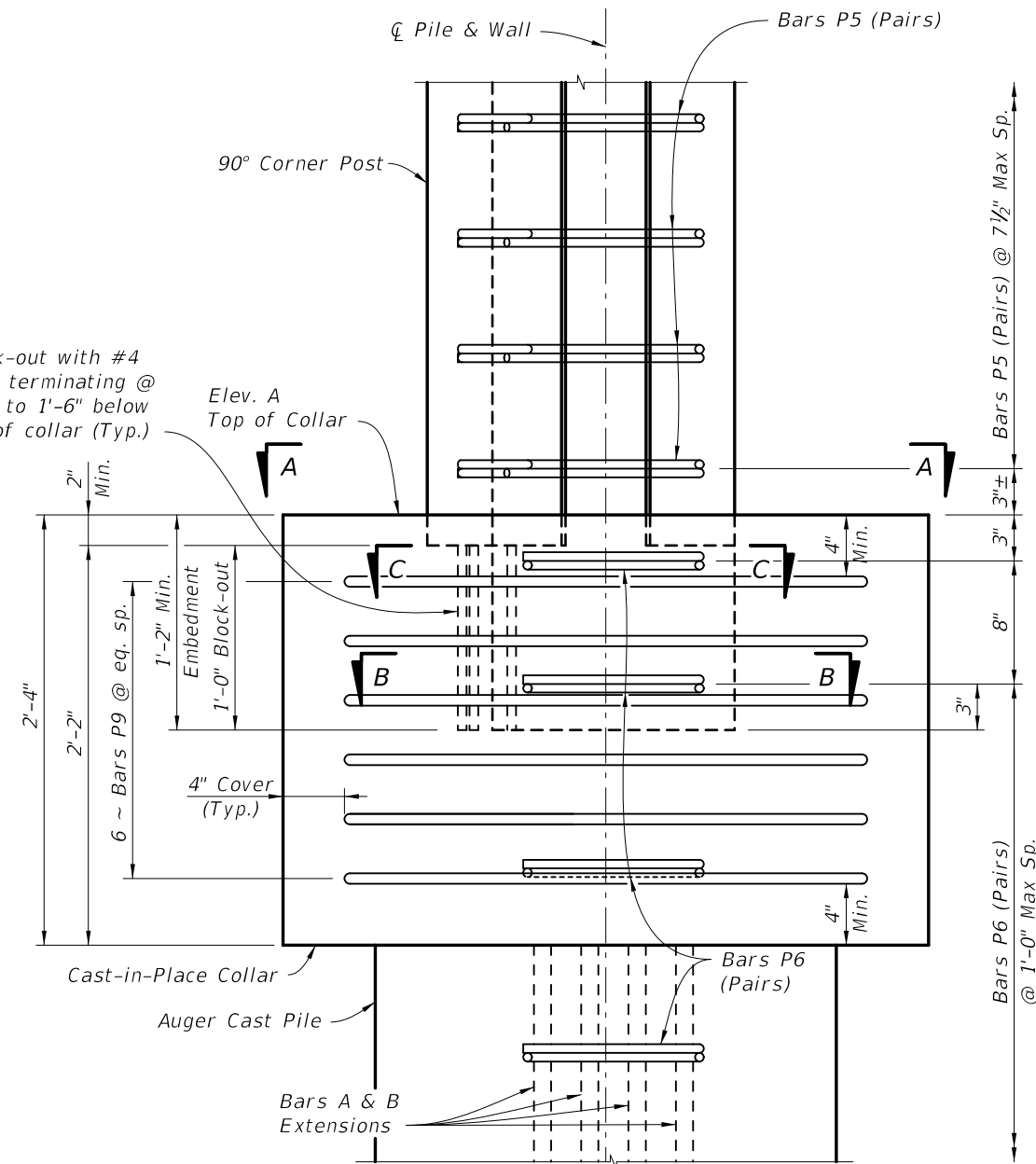

VIEW D-D
PARTIAL ELEVATION OF POST
(Vertical Reinforcing not shown for clarity)

NOTES:

1. Use 3'-6" CIP Collar for all 90° corner posts, Bars P10 not required for 90° corner pile collar.
2. For Post & Pile Lengths, see Sheet Nos. 14 & 15.
3. For Table of Reinforcing Steel, see Sheet Nos. 14 & 15.
4. Reduce standard panel length or adjust post spacing by 3/8" at each 90° Corner Post to accommodate the Special Post dimensions.

SPECIAL 90° CORNER POST

REVISIONS			
DATE	BY	DESCRIPTION	DATE
01/01/11	CMH	New Sheet from Index No. 5202 (Sheet 4 of 6). Deleted Options A B & E. Added Block-out Detail.	

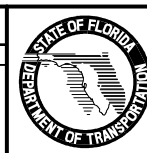

2010 Interim Design Standard	
PRECAST SOUND BARRIERS	

Interim Date	Sheet No.
01/01/11	11 of 15
Index No.	
5200	

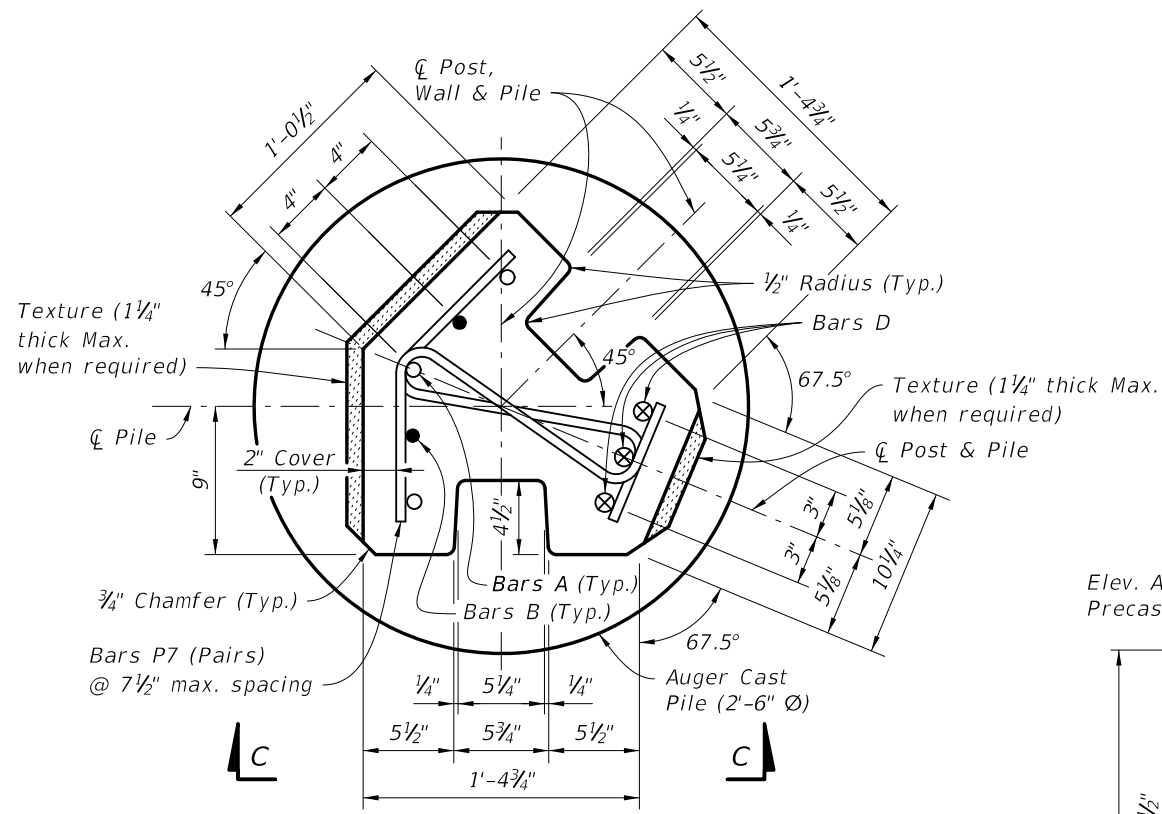

SECTION A-A
TYPICAL SECTION ABOVE PILE

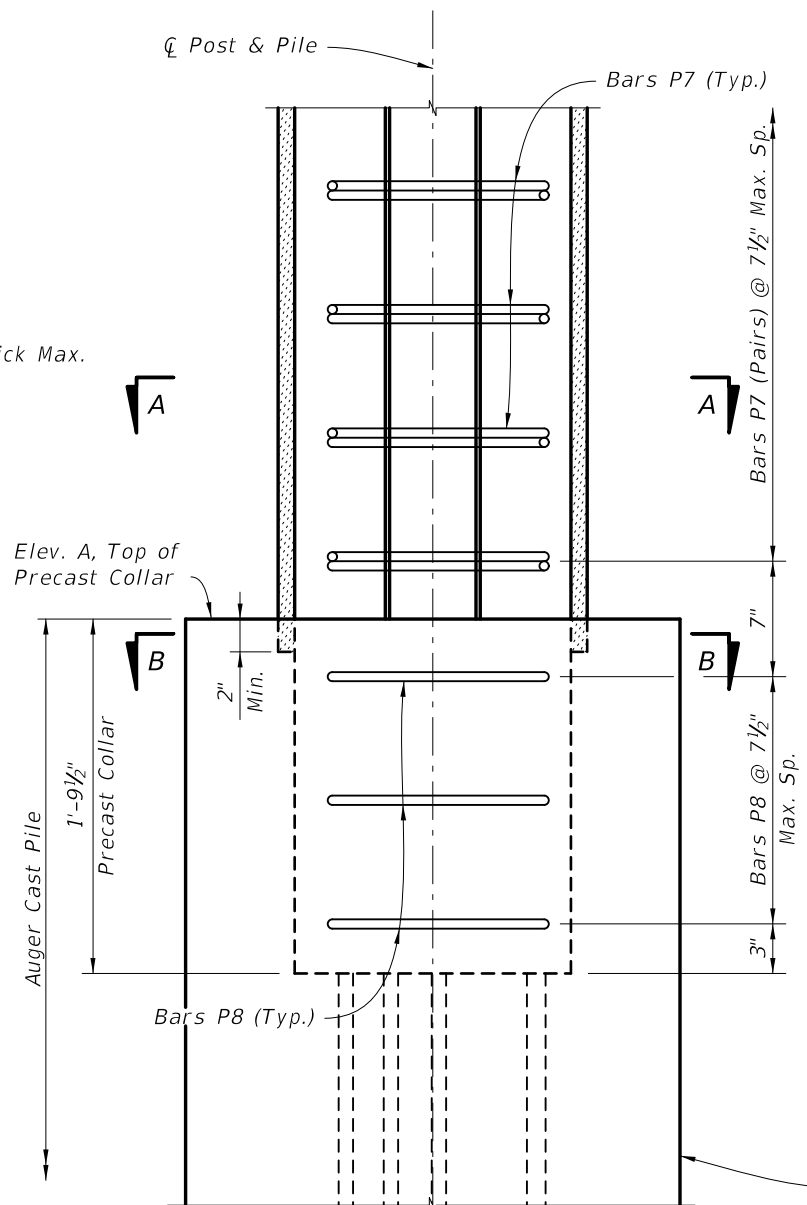

VIEW C-C (PARTIAL ELEVATION)
PRECAST COLLAR
(Only Front Face shown for Clarity)

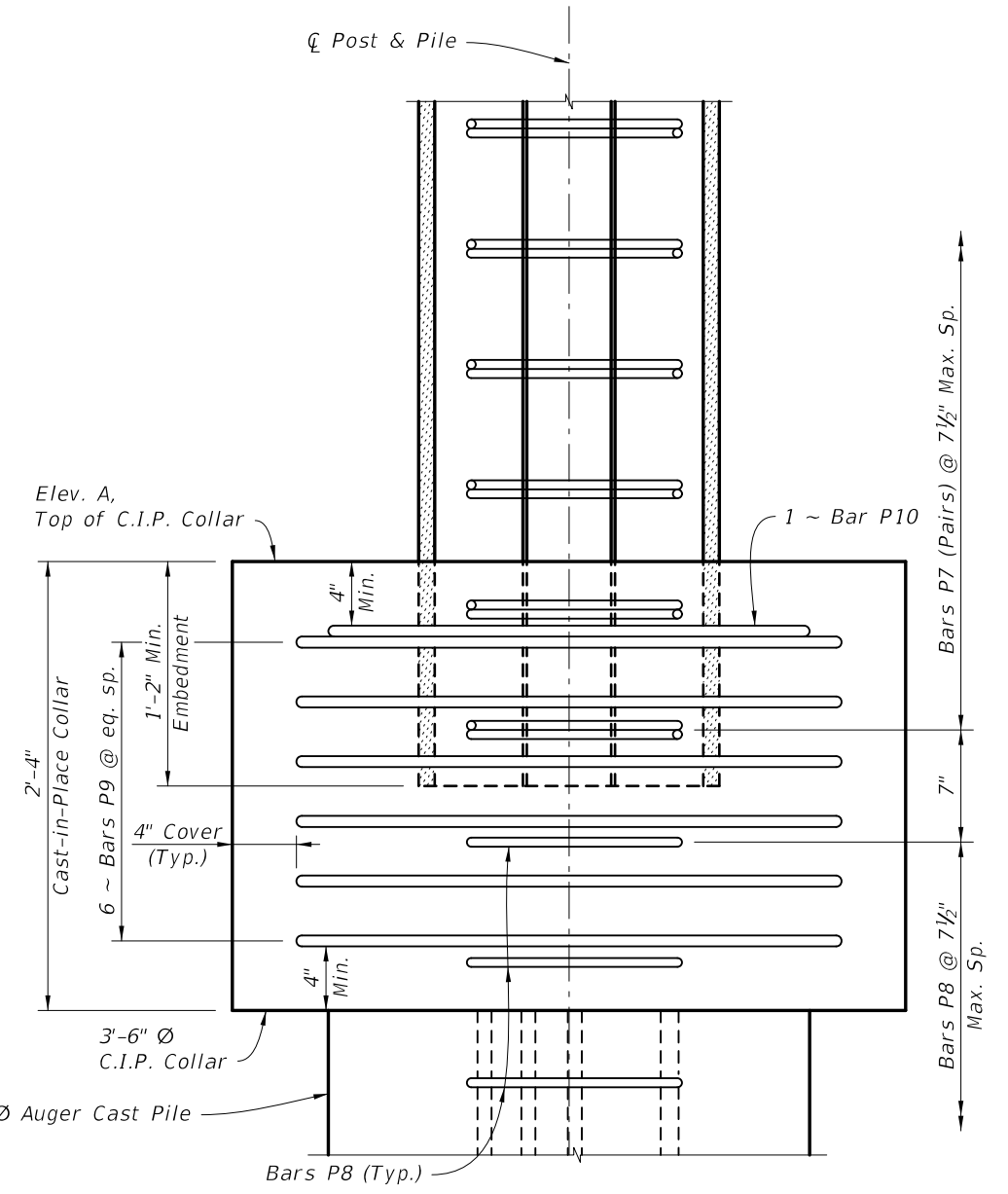

PARTIAL ELEVATION
3'-6" Ø CAST-IN-PLACE COLLAR
(Only Front Face shown for Clarity)

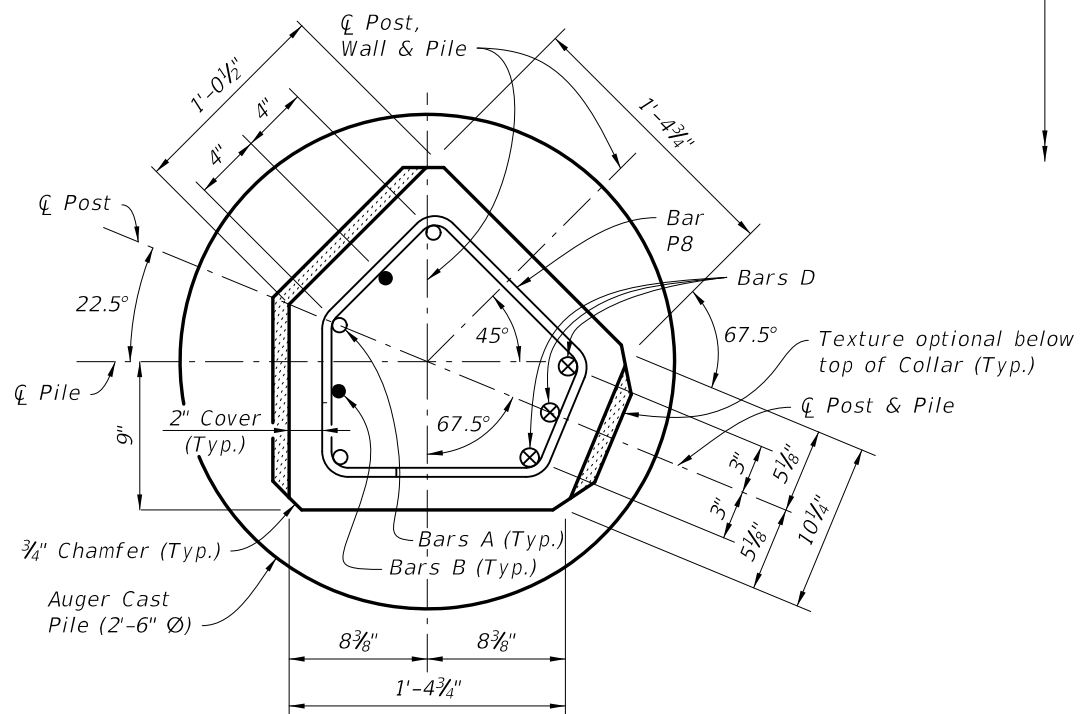

SECTION B-B
PRECAST COLLAR SECTION

NOTE:
For Table of Reinforcing Steel Sizes and
Post & Pile Lengths, see Sheet Nos. 14 & 15.

SPECIAL 45° CORNER POST

REVISIONS			
DATE	BY	DESCRIPTION	
01/01/11	CMH	New Sheet from Index No. 5202 (Sheet 5 of 6). Deleted Options A, B, C & D.	

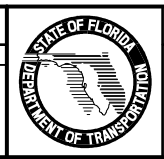

2010 Interim Design Standard
PRECAST SOUND BARRIERS

Interim Date: 01/01/11
Sheet No.: 12 of 15
Index No.: **5200**

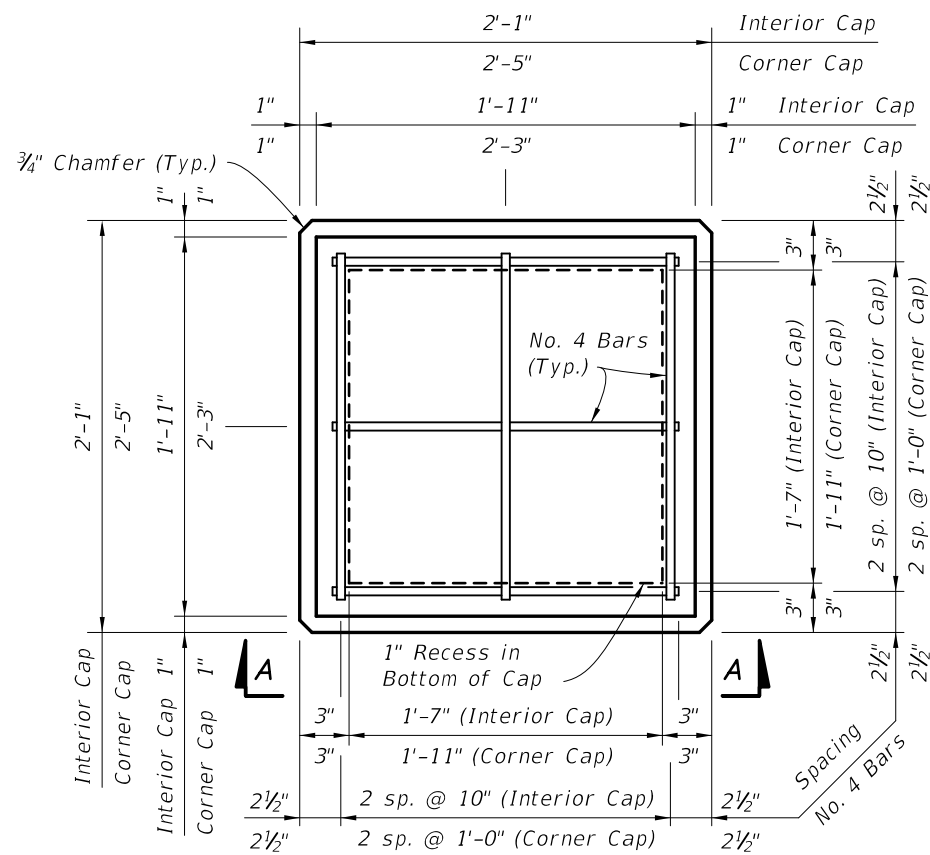

PLAN VIEW
(Type "A" Cap Shown, Type "B" & "C" Caps Similar)

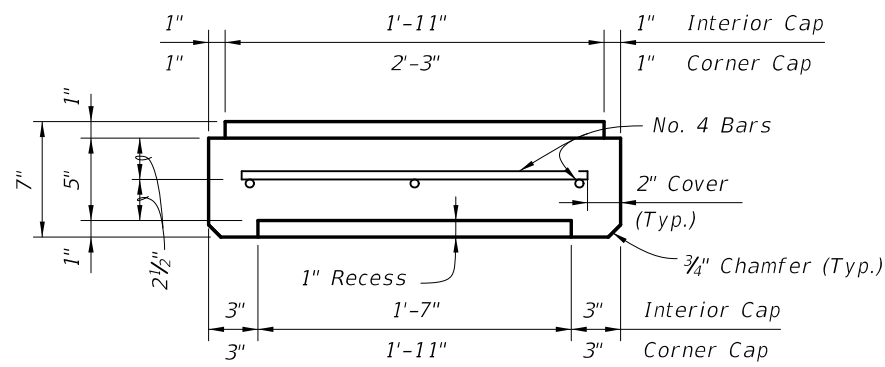

SECTION C-C

TYPE "A" CAP DETAILS

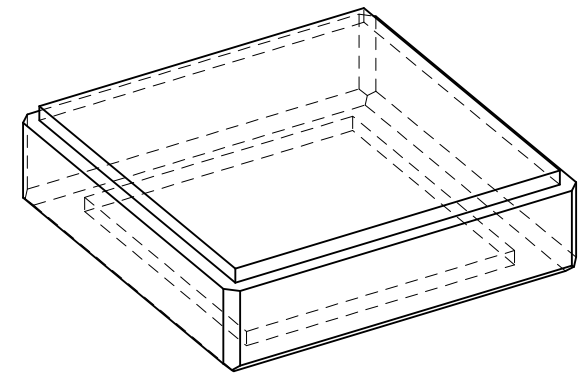

PICTORIAL VIEW

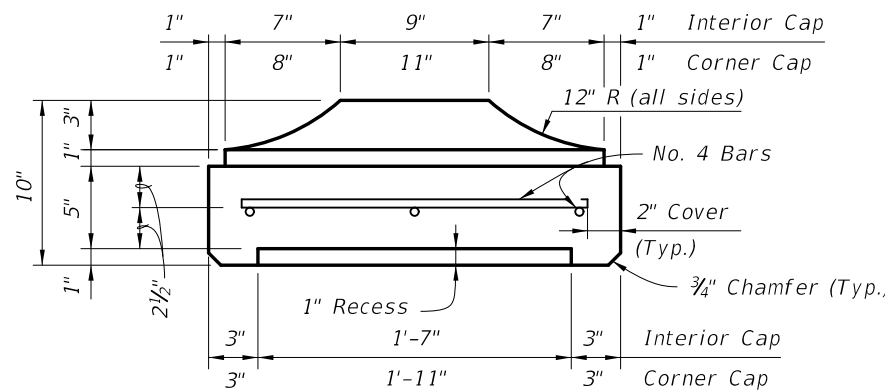

SECTION C-C

TYPE "B" CAP DETAILS

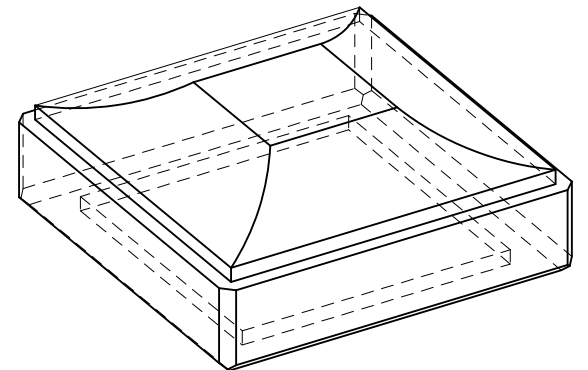

PICTORIAL VIEW

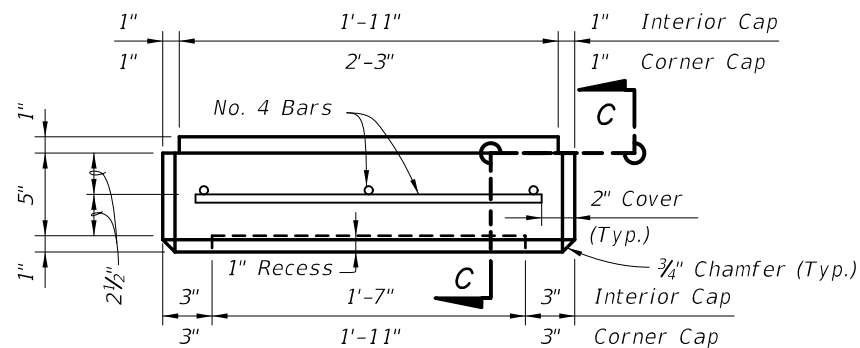

VIEW A-A SHOWN, VIEW B-B SIMILAR
(Type "A" Cap Shown, Type "B" & "C" Caps Similar)

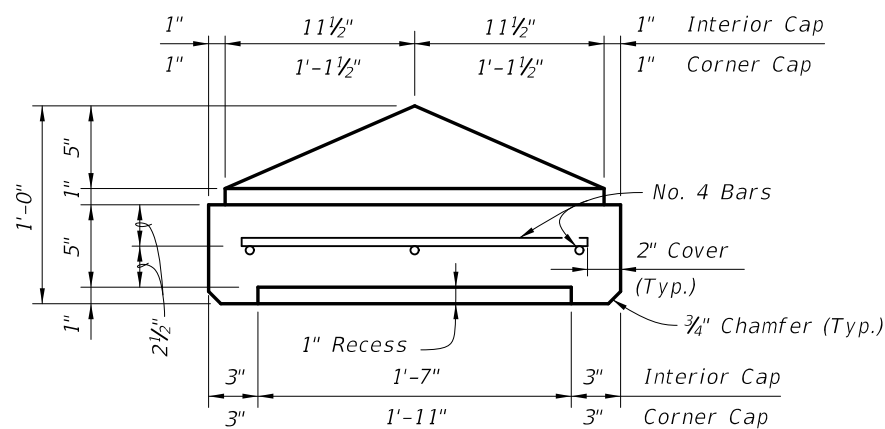

SECTION C-C

TYPE "C" CAP DETAILS

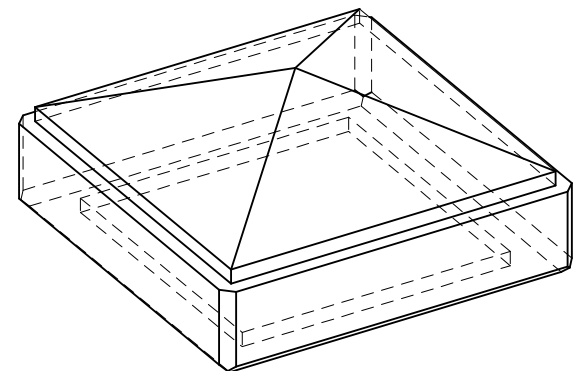

PICTORIAL VIEW

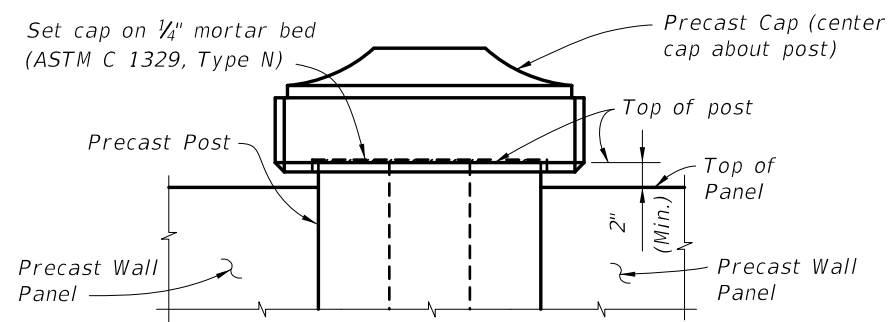

CAP PLACEMENT DETAIL
(Type "B" Cap Shown, Type "A" & "C" Caps Similar)

PRECAST POST CAPITAL

REVISIONS

DATE	BY	DESCRIPTION	DATE	BY	DESCRIPTION
01/01/11	CMH	New Sheet from Index No. from 5207.			

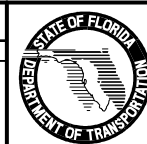

2010 Interim Design Standard

PRECAST SOUND BARRIERS

Interim Date: 01/01/11
Sheet No.: 13 of 15

Index No.: **5200**

BAR BENDING DETAILS

All bar dimensions in bending diagrams are out-to-out. All bars not shown in the bending diagrams are straight.

POST & PILE

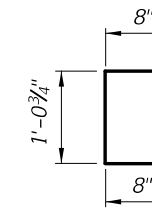

BAR P1
Bar Length = 2'-5"

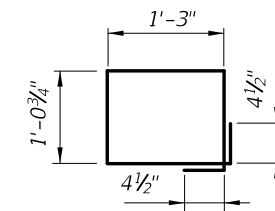

BAR P2
Bar Length = 5'-5"

90° CORNER POST & PILE

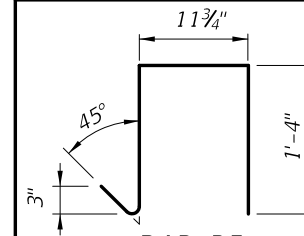

BAR P5
Bar Length = 4'-0"

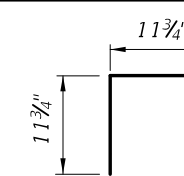

BAR P6
Bar Length = 2'-11 1/4"

CAST-IN-PLACE COLLAR

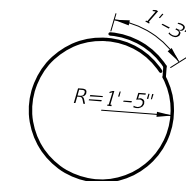

BAR P9
Bar Length = 10'-2"

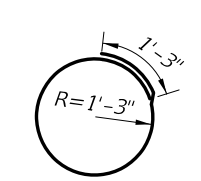

BAR P10
Bar Length = 9'-2"

45° CORNER POST & PILE

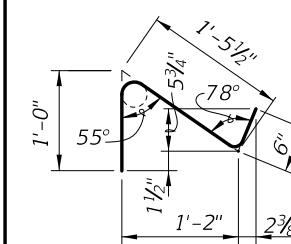

BAR P7 (POST)
Bar Length = 2'-8"

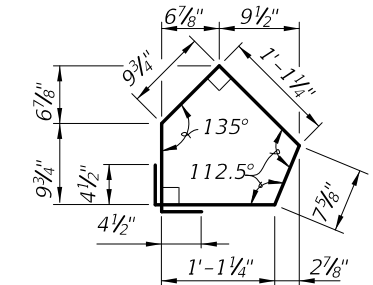

BAR P8 (PILE)
Bar Length = 5'-0 1/4"

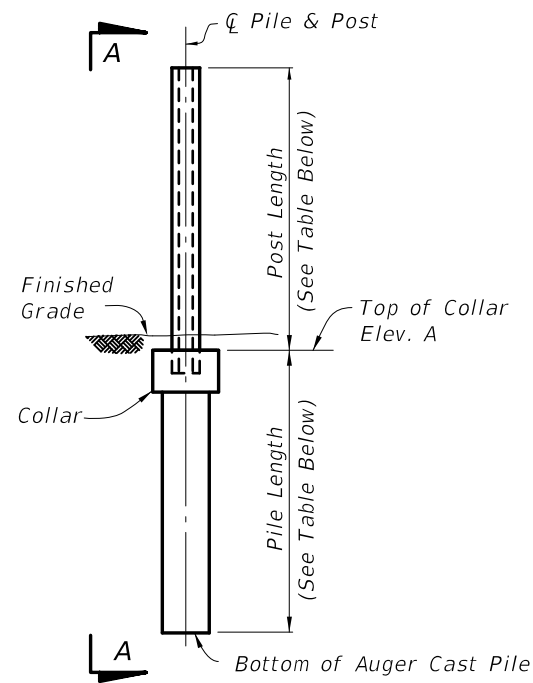

PILE/POST ELEVATION

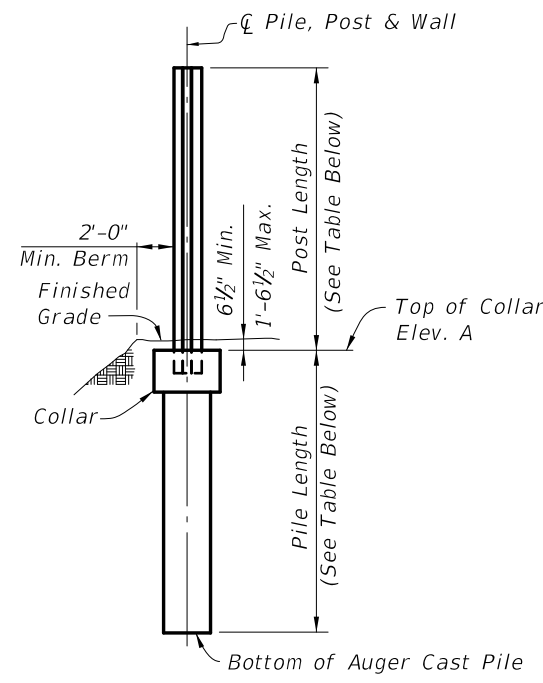

VIEW A-A

NOTES:

- Bars P5 & P6 are only used in 90° Corner Posts.
- Bars P7, P8 & D are only used in 45° Corner Posts.
- Bars P9 & P10 are used in the Cast-In-Place Collar Option.
- For Bar Designations, see Sheet Nos. 9 - 12.

TABLE 1 - FOUNDATIONS FOR MEDIUM DENSE GRANULAR SOILS (Soil SPT N₆₀ Values between 10 and 40)

POST AND PILE DIMENSIONS					TABLE OF REINFORCING STEEL											
WALL TYPE	POST LENGTH WITHOUT CAP	POST LENGTH WITH CAP	PILE LENGTH		PILE/POST REINFORCING										CAST-IN-PLACE COLLAR	
			10'-0" POST SPACING	20'-0" POST SPACING	10'-0" POST SPACING				20'-0" POST SPACING				BARS P1, P2, P5, P6, P7 & P8	BARS P9	BARS P10	
					BARS A	BARS B		BARS D	BARS A	BARS B		BARS D				
SIZE	SIZE	DIM 'A'	SIZE	SIZE	SIZE	SIZE	DIM 'A'	SIZE	SIZE	SIZE	DIM 'A'	SIZE	SIZE	SIZE	SIZE	
A	12'-0 1/2"	12'-2 1/2"	12'-0"	15'-0"	#4	#4	10'-0"	#4	#5	#5	9'-0"	#6	#4	#5	#5	
B	13'-0 1/2"	13'-2 1/2"	12'-0"	16'-0"	#4	#4	10'-7"	#5	#5	#5	8'-10"	#7	#4	#5	#5	
C	14'-0 1/2"	14'-2 1/2"	13'-0"	17'-0"	#4	#4	10'-5"	#5	#6	#6	10'-4"	#7	#4	#5	#5	
D	15'-0 1/2"	15'-2 1/2"	13'-0"	18'-0"	#5	#5	12'-11"	#6	#6	#6	10'-3"	#8	#4	#5	#5	
E	16'-0 1/2"	16'-2 1/2"	14'-0"	18'-0"	#5	#5	12'-9"	#6	#7	#7	11'-10"	#8	#4	#5	#5	
F	17'-0 1/2"	17'-2 1/2"	14'-0"	19'-0"	#5	#5	12'-7"	#6	#7	#7	11'-8"	#9	#4	#5	#5	
G	18'-0 1/2"	18'-2 1/2"	15'-0"	20'-0"	#6	#6	14'-11"	#7	#8	#8	13'-1"	#10	#4	#5	#5	
H	19'-0 1/2"	19'-2 1/2"	15'-0"	21'-0"	#6	#6	14'-10"	#7	#8	#8	13'-0"	#10	#4	#5	#5	
I	20'-0 1/2"	20'-2 1/2"	16'-0"	22'-0"	#6	#6	14'-9"	#8	#9	#9	14'-3"	#11	#4	#5	#5	
J	21'-0 1/2"	21'-2 1/2"	16'-0"	24'-0"	#6	#6	14'-8"	#8	#9	#9	14'-2"	#11	#4	#5	#5	
K	22'-0 1/2"	22'-2 1/2"	17'-0"	26'-0"	#7	#7	17'-1"	#8	#9	#9	14'-1"	2~ #14 & 1 ~ #9	#4	#5	#5	

PILE DEPTH & REINFORCING SUMMARY

REVISIONS

DATE	BY	DESCRIPTION	DATE	BY	DESCRIPTION
01/01/11	CMH	New Sheet from Index No. 5206 (Sheet 1 of 2). Deleted Options A, B, C & D.			

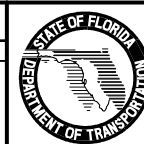

2010 Interim Design Standard

PRECAST SOUND BARRIERS

Interim Date: 01/01/11
Sheet No.: 14 of 15

Index No.: **5200**

TABLE 2 - FOUNDATIONS FOR LOOSE GRANULAR SOILS (SPT N₆₀ Values between 4 and 9)

POST AND PILE DIMENSIONS					TABLE OF REINFORCING STEEL										
WALL TYPE	POST LENGTH WITHOUT CAP	POST LENGTH WITH CAP	PILE LENGTH		PILE/POST REINFORCING									CAST-IN-PLACE COLLAR	
			10'-0" POST SPACING	20'-0" POST SPACING	10'-0" POST SPACING			20'-0" POST SPACING			BARS P1, P2, P5, P6, P7 & P8	BARS P9	BARS P10		
					BARS A	BARS B		BARS D	BARS A	BARS B				BARS D	
SIZE	SIZE	DIM 'A'	SIZE	SIZE	SIZE	DIM 'A'	SIZE	SIZE	SIZE	DIM 'A'	SIZE	SIZE	SIZE	SIZE	
A	12'-0½"	12'-2½"	13'-0"	17'-0"	#4	#4	10'-0"	#4	#5	#5	9'-0"	#6	#4	#5	#5
B	13'-0½"	13'-2½"	14'-0"	18'-0"	#4	#4	10'-7"	#5	#5	#5	8'-10"	#7	#4	#5	#5
C	14'-0½"	14'-2½"	14'-0"	19'-0"	#4	#4	10'-5"	#5	#6	#6	10'-4"	#7	#4	#5	#5
D	15'-0½"	15'-2½"	15'-0"	20'-0"	#5	#5	12'-11"	#6	#6	#6	10'-3"	#8	#4	#5	#5
E	16'-0½"	16'-2½"	16'-0"	21'-0"	#5	#5	12'-9"	#6	#7	#7	11'-10"	#8	#4	#5	#5
F	17'-0½"	17'-2½"	16'-0"	22'-0"	#5	#5	12'-7"	#6	#7	#7	11'-8"	#9	#4	#5	#5
G	18'-0½"	18'-2½"	17'-0"	23'-0"	#6	#6	14'-11"	#7	#8	#8	13'-1"	#10	#4	#5	#5
H	19'-0½"	19'-2½"	18'-0"	25'-0"	#6	#6	14'-10"	#7	#8	#8	13'-0"	#10	#4	#5	#5
I	20'-0½"	20'-2½"	18'-0"	26'-0"	#6	#6	14'-9"	#8	#9	#9	14'-3"	#11	#4	#5	#5
J	21'-0½"	21'-2½"	19'-0"	29'-0"	#6	#6	14'-8"	#8	#9	#9	14'-2"	#11	#4	#5	#5
K	22'-0½"	22'-2½"	19'-0"	*	#7	#7	17'-1"	#8	#9	#9	14'-1"	2~ #14 & 1 ~ #9	#4	#5	#5

* Do not use for walls with 30" dia. foundations, 20' spacing, & greater than 21' high.

PILE DEPTH & REINFORCING SUMMARY

REVISIONS				2010 Interim Design Standard				Interim Date	Sheet No.
DATE	BY	DESCRIPTION	DATE	BY	DESCRIPTION	01/01/11		15 of 15	
01/01/11	CMH	New Sheet from Index No. 5206 (Sheet 2 of 2). Deleted Options A, B, C & D.							
						PRECAST SOUND BARRIERS		Index No.	
								5200	