

HIGHMAST LIGHTING NOTES:

- 1) High Mast materials:
 - a. Pole: ASTM A1011 Grade 50, 55, 60 or 65 (Less than 1/4") or ASTM A572 Grade 50, 55, 60, or 65 (1/4" and over) or ASTM A595 Grade A (55 ksi yield) or Grade B (60 ksi yield).
 - b. Steel Plates: ASTM A709 Grade 36 or ASTM A36
 - c. Weld Metal: E70XX
 - d. Anchor Bolts: ASTM F1554 Grade 55 with ASTM A563, Grade A heavy-hex nuts and plate washer.
 - e. Handhole: ASTM A709 Grade 36 or ASTM A36 Frame with ASTM A36 cover.
 - f. Caps: ASTM A1011 Grade 50, 55, 60 or 65 or ASTM B209.
 - g. Nut Covers: ASTM B26 (319-F)
 - h. Stainless Steel Screws: AISI Type 316
- 2) Reinforcing steel: ASTM A615, Grade 60.
- 3) Concrete: Class IV (Drilled Shaft) with a minimum 4,000 psi compressive strength at 28 days for all environmental classifications.
- 4) Welding: American Welding Society Structural Welding Code (Steel) ANSI/AWS D1.1 (Current edition).
- 5) Galvanization:
 - a. Nuts, Bolts, Washers and Threaded Bars/Studs: ASTM F2329.
 - b. Other items (Including Pole): ASTM A123
- 6) Hole diameters for anchor bolts: not greater than the bolt diameter plus 1/2".
- 7) Poles: Tapered with the diameter changing at a rate of 0.14 inch per foot with a minimum 16-sided pole shaft and only one longitudinal seam weld. Circumferentially welded pole shaft butt splices and laminated pole shafts are not permitted. Longitudinal seam welds within 6 inches of pole to base must be complete penetration welds. Longitudinal seam welds at telescopic field joints must be complete penetration welds for the splice length plus 6 inches. Fillet weld socket connections with unequal leg welds with the long weld leg along the shaft. Terminate the long weld leg along the shaft at approximately a 30 degree angle.
- 8) One hundred percent of full-penetration groove welds and a random 25 percent of partial penetration groove welds shall be inspected. Full-penetration groove weld inspection shall be performed by nondestructive methods of radiography or ultrasonics.
- 9) Furnish each pole with a 2"x4" (Max.) aluminum identification tag. Submit details for approval. Secure to pole with 0.124" stainless steel rivets or screws. Locate identification tag on the inside of pole and visible from handhole. Include the following information:
 Financial Project ID,
 Pole Mounting Height,
 Manufacturer's Name, F_y of Steel and
 Base Wall Thickness.
- 10) Shop drawings are only required for additions, deletions, or modifications to this Design Standard.
- 11) Verify CSL access tubes will not interfere with anchor bolt installation before excavating the shaft. When CSL access tube locations conflict with anchor bolt locations, move the CSL access tube location ± two inches along the inner circumference of the reinforcing cage. Notify the Engineer before excavating the shaft if the CSL access tube locations cannot be moved out of conflict with anchor bolt locations.

DESIGN CRITERIA:

- 1) Designed in accordance with the FDOT Structures Manual.
- 2) Poles are designed to support the following:
 - a. (1) cylindrical head assembly with a maximum effective projected area of 6 sq ft (Cd=1) and 340 lbs (Max).
 - b. (8) cylindrical luminaires with a maximum effective projected area of 3.0 sq ft (Cd=0.5) and 77 lbs. each.
- 3) Foundation design based upon the following soil criteria:
 Classification = Cohesionless (Fine Sand)
 Friction Angle = 30 Degrees (30°)
 Unit Weight = 50 pcf (assumed saturated)

 Only in cases where the Designer considers the soil types at the specific site location to be of lesser strength properties should an analysis be required. Auger borings, SPT borings or CPT soundings may be utilized as needed to verify the assumed soil properties, and at relatively uniform sites, a single boring or sounding may cover several foundations. Furthermore, borings in the area that were performed for other purposes may be used to confirm the assumed soil properties.
- 4) Foundation applies only to slopes of 1:4 or flatter. Provide a minimum 24" shaft projection on the high side.
- 5) Poles are designed for 6 mil galvanization thickness.

STANDARD POLE DESIGN NOTES

REVISIONS							2010 Interim Design Standard		Interim Date	Sheet No.
DATE	BY	DESCRIPTION	DATE	BY	DESCRIPTION		HIGHMAST LIGHTING		01/01/11	3 of 7
07/01/10	DYW	Modified washer specification.							Index No. 17502	
01/01/11	DYW	Changed Notes 7, 9 and 10.								

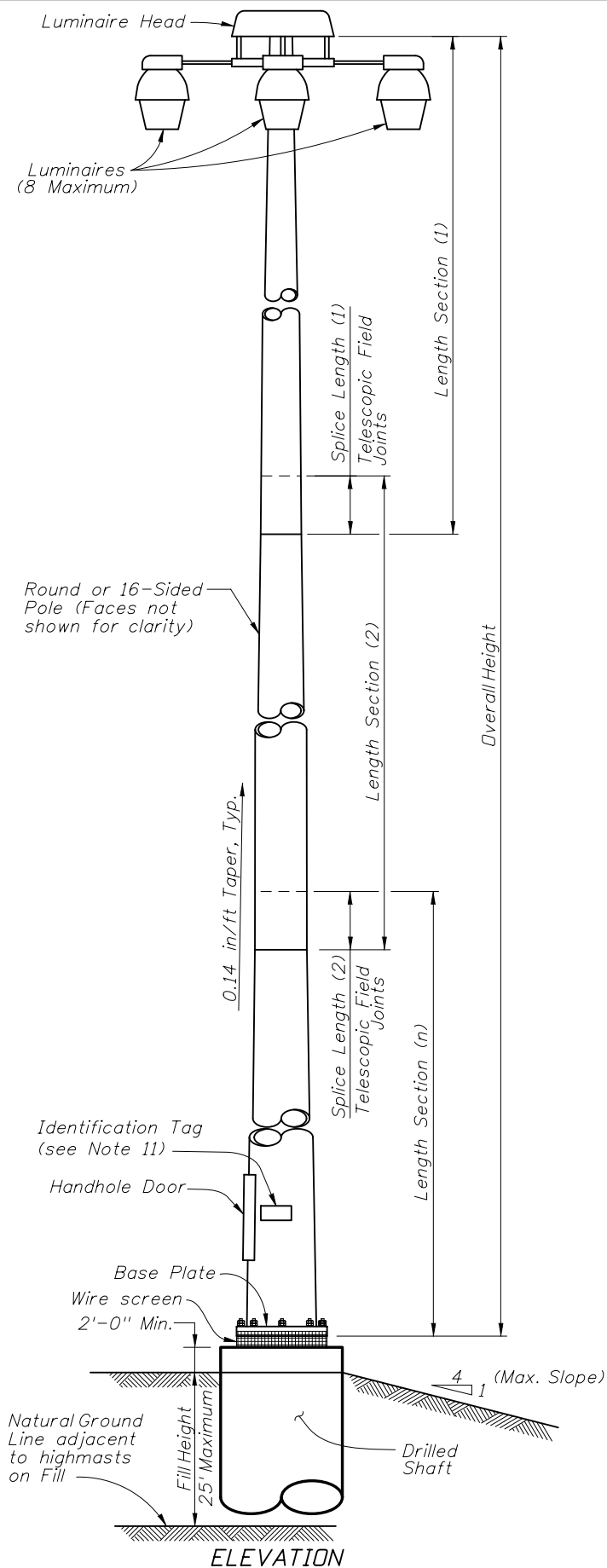

POLE DESIGN TABLE*																
DESIGN WIND SPEED	POLE OVERALL HEIGHT	SECTION 1 (TOP)					SECTION 2					SECTION 3				
		Length	Wall Thickness (in.)	Minimum Splice L.	Tip Dia. (in.)	Base Dia. (in.)	Length	Wall Thickness (in.)	Minimum Splice L.	Tip Dia. (in.)	Base Dia. (in.)	Length	Wall Thickness (in.)	Minimum Splice L.	Tip Dia. (in.)	Base Dia. (in.)
110 mph	80 ft	42'-0"	0.250	2'-0"	5.313	11.219	40'-0"	0.250		10.375	16.000					
	100 ft	24'-6"	0.179	2'-0"	6.406	9.844	40'-0"	0.250	2'-6"	9.188	14.781	40'-0"	0.250		13.875	19.5
	120 ft	44'-9"	0.250	2'-0"	6.250	12.531	40'-0"	0.250	2'-9"	11.688	17.313	40'-0"	0.313		16.375	22.0
130 mph	80 ft	42'-0"	0.250	2'-0"	5.281	11.188	40'-0"	0.313		10.375	16.000					
	100 ft	24'-6"	0.179	2'-0"	6.906	10.344	40'-0"	0.250	2'-6"	9.656	15.281	40'-0"	0.313		14.375	20.0
	120 ft	45'-6"	0.250	2'-6"	9.250	15.625	40'-0"	0.250	3'-0"	14.719	20.344	40'-0"	0.313		19.375	25.0
150 mph	80 ft	42'-3"	0.250	2'-3"	7.281	13.219	40'-0"	0.313		12.375	18.000					
	100 ft	24'-6"	0.250	2'-0"	8.188	11.625	40'-0"	0.313	2'-6"	10.781	16.406	40'-0"	0.375		15.375	21.0
	120 ft	46'-6"	0.250	3'-0"	12.406	18.938	40'-0"	0.313	3'-6"	17.938	23.563	40'-0"	0.375		22.375	28.0

* Diameter Measured Flat to Flat

BASE PLATE AND BOLTS DESIGN TABLE									
DESIGN WIND SPEED	POLE OVERALL HEIGHT	Base Plate Diameter (in.)	Base Plate Thickness (in.)	"TW" (in.)	"BW" (in.)	Bolt Circle (in.)	No. Bolts	Bolt Diameter (in.)	Bolt Embedment (in.)
110 mph	80 ft	30.0	3.0	0.375	0.188	23.0	8	1.75	38
	100 ft	33.5	3.0	0.375	0.188	26.5	8	1.75	42
	120 ft	36.0	3.0	0.375	0.250	29.0	8	1.75	45
130 mph	80 ft	30.0	3.0	0.438	0.250	23.0	8	1.75	43
	100 ft	34.0	3.0	0.438	0.250	27.0	8	1.75	50
	120 ft	41.0	3.5	0.500	0.250	33.0	8	2.00	52
150 mph	80 ft	32.0	3.0	0.500	0.250	25.0	8	1.75	49
	100 ft	37.0	3.0	0.563	0.313	29.0	8	2.00	53
	120 ft	46.0	3.5	0.563	0.313	37.0	10	2.25	57

SHAFT DESIGN TABLE				
DESIGN WIND SPEED	POLE OVERALL HEIGHT	Shaft Diameter	Shaft Length	Longitudinal Reinforcement
110 mph	80 ft	4'-0"	13'-0"	14- #11
	100 ft	4'-6"	14'-0"	16- #11
	120 ft	4'-6"	16'-0"	16- #11
130 mph	80 ft	4'-0"	14'-0"	14- #11
	100 ft	4'-6"	16'-0"	16- #11
	120 ft	5'-0"	17'-0"	18- #11
150 mph	80 ft	4'-6"	15'-0"	16- #11
	100 ft	4'-6"	17'-0"	16- #11
	120 ft	5'-0"	20'-0"	18- #11

POLE DESIGN TABLES

REVISIONS			REVISIONS				2010 Interim Design Standard		Interim Date	Sheet No.
DATE	BY	DESCRIPTION	DATE	BY	DESCRIPTION		HIGHMAST LIGHTING		01/01/11	4 of 7
01/01/09	CBH	Deleted grout pad, added wire screen, changed drilled shaft reinforcing.								
01/01/11	CBH	Updated values in BASE PLATE AND BOLTS DESIGN TABLE and SHAFT DESIGN TABLE.								Index No. 17502

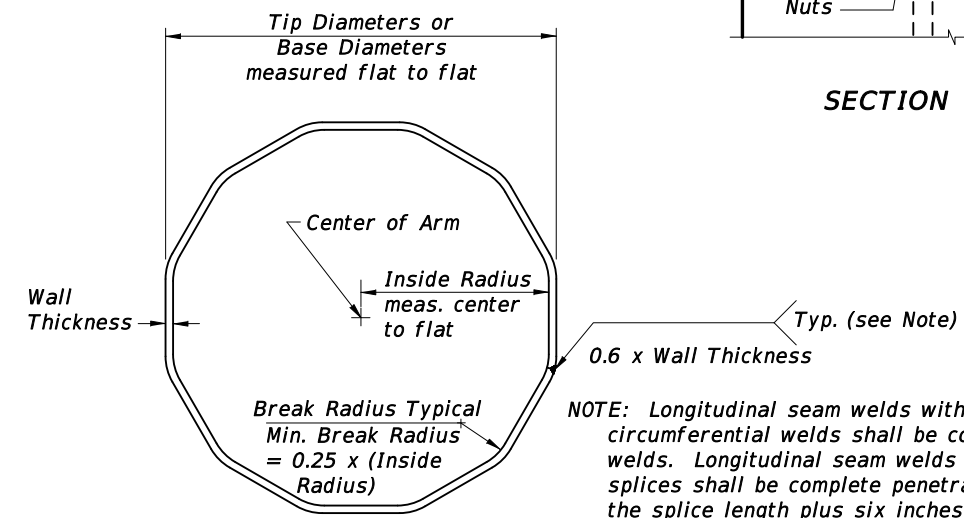
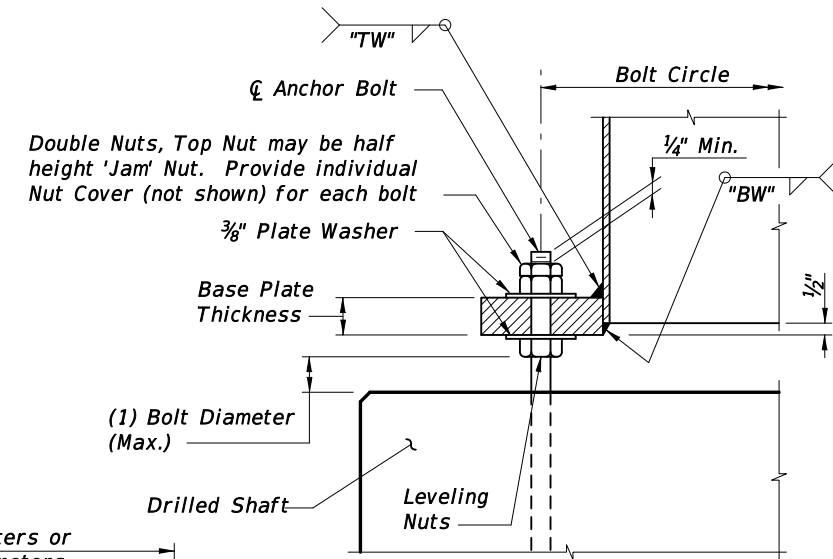
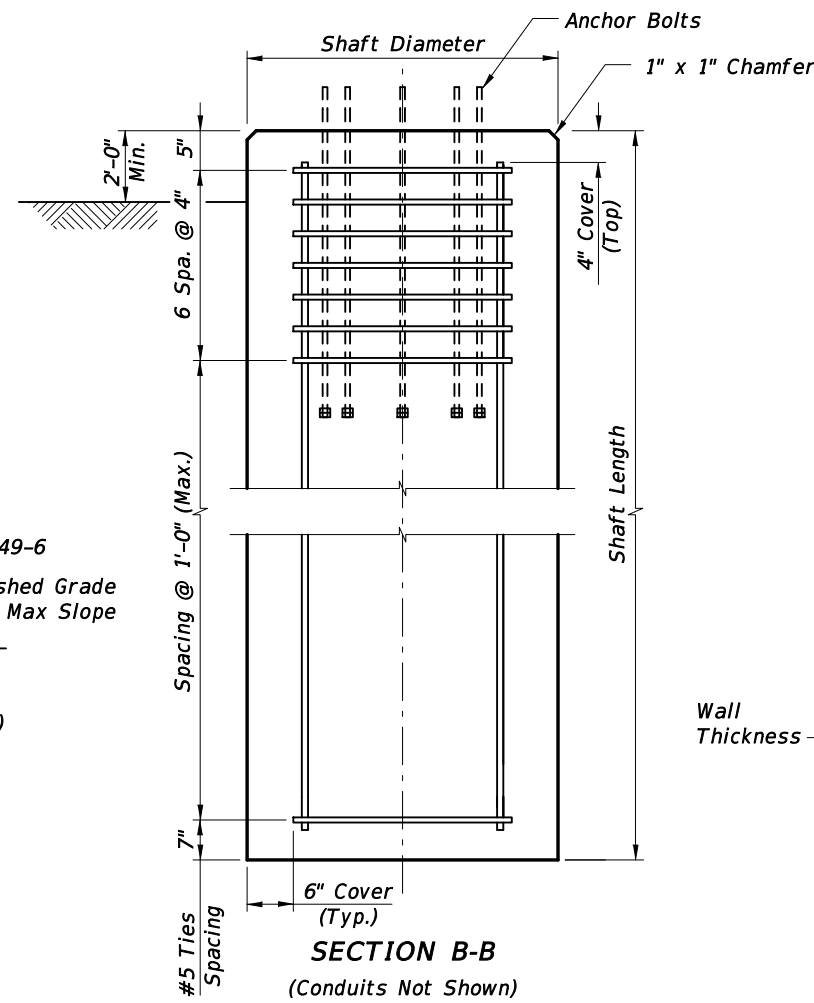
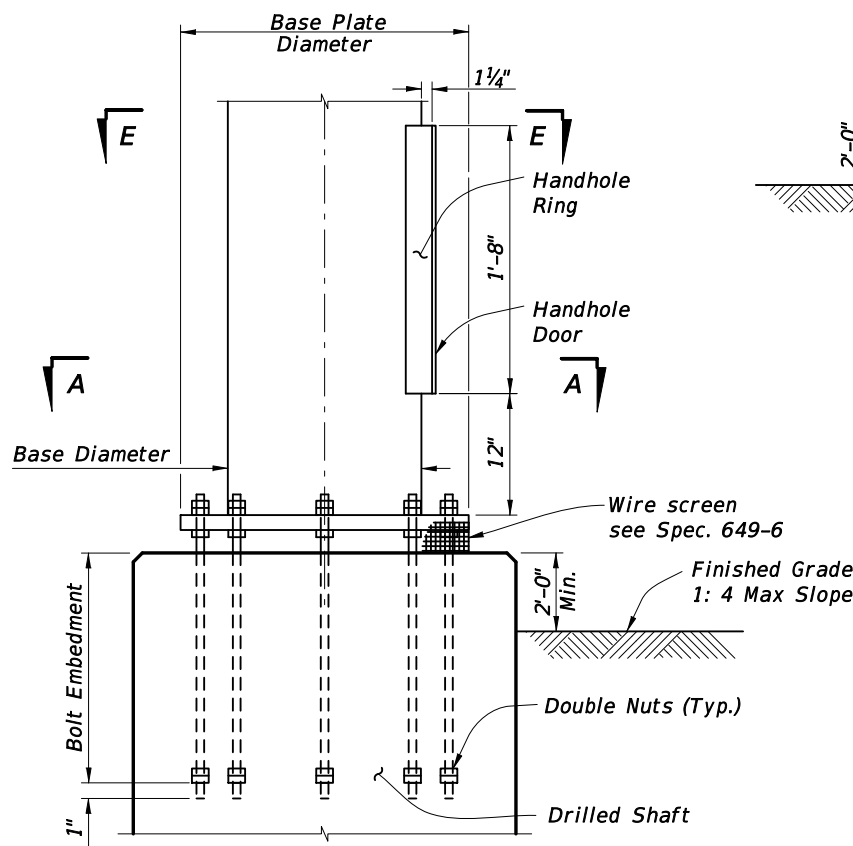
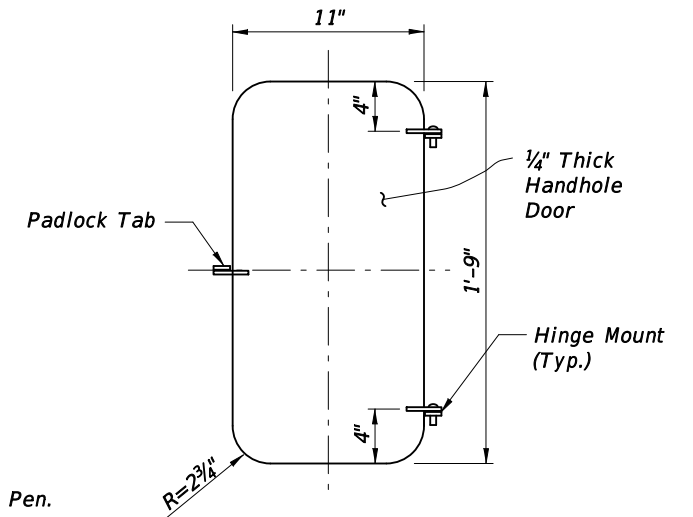
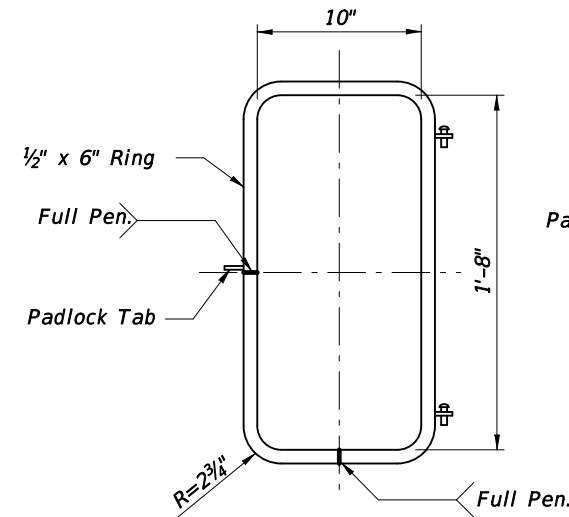
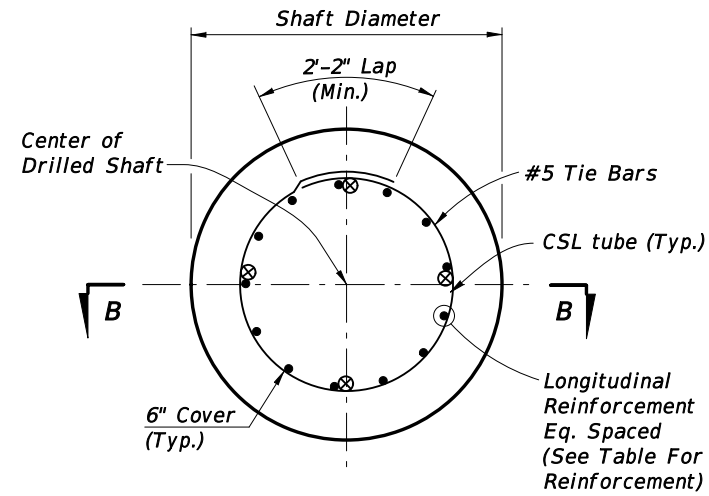
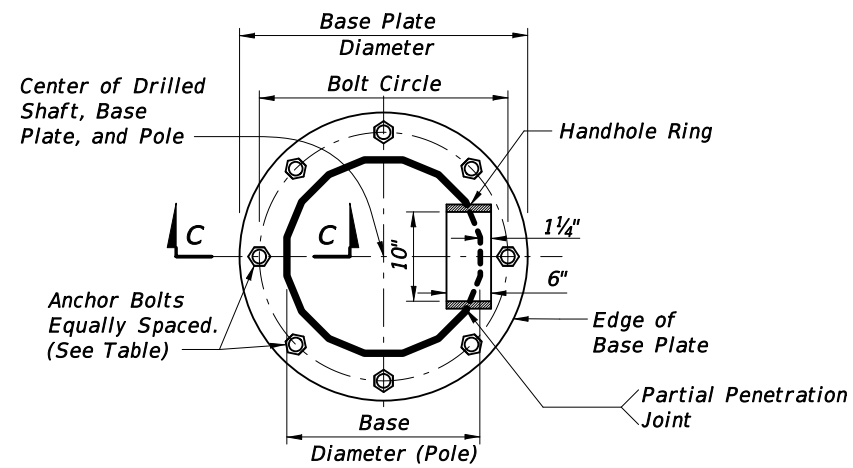

NOTE: Longitudinal seam welds within six inches of circumferential welds shall be complete penetration welds. Longitudinal seam welds at telescopic field splices shall be complete penetration welds for the splice length plus six inches.

POLE FOUNDATION

REVISIONS

DATE	BY	DESCRIPTION	DATE	BY	DESCRIPTION
07/01/10	DYW	Modified longitudinal seam weld note & R washer thickness.			
01/01/11	CBH	Revised SECTION B-B Tie Spacing			

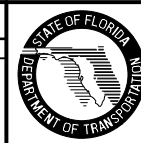

2010 Interim Design Standard

HIGHMAST LIGHTING

Interim Date
01/01/11
Sheet No.
5 of 7
Index No.
17502