

DESIGN STANDARDS

FOR DESIGN, CONSTRUCTION, MAINTENANCE AND UTILITY
OPERATIONS ON THE STATE HIGHWAY SYSTEM

2010

TOPIC NO. 625-010-003

Approved For Use On Federal Aid Projects

For Martin Knopp, Division Administrator

State of Florida, Department Of Transportation
Roadway Design Office
Mail Station 32
605 Suwannee Street
Tallahassee, Florida 32399-0450

NOTICE

These Design Standards are intended to support the various engineering obligations for designing, constructing, inspecting, maintaining and monitoring the highways, roads and streets on the State Highway System. They are prepared to encourage uniform application of designs and standard details in the preparation of project plans. These Standards may be adopted by other authorities for use on projects under their jurisdiction.

It is the responsibility of the Design Engineer of Record using these Standards to determine the fitness for a particular use of each standard in the design of a project. The inappropriate use of and adherence to these standards does not exempt the engineer from the professional responsibility of developing an appropriate design.

PATENTED DEVICES, MATERIALS AND PROCESSES

The use of any design, method, process, material or device either expressed or implied by these standards that are covered by patent, copyright, or proprietary privilege is the sole responsibility of the user. Any infringement on the rights of the inventor, patentee, assignee or licensee shall be the sole responsibility of the user. For additional information refer to Subsection 7-3 of the FDOT Standard Specifications for Road and Bridge Construction.

Distribution of Exempt Public Documents:

It is the policy of the Department to protect the State Highway System's infrastructure from disclosure under Florida's public records law for documents concerning Department structures. This exemption is created by Section 119.07(3)(ee), F.S. and covered by Department Procedure "Distribution of Exempt Public Documents Concerning Department Structures and Security System Plans (Topic No. 050-020-026)." Structure is defined in Section 334.03(28), F.S., as "a bridge, viaduct, tunnel, causeway, approach, ferry slip, culvert, toll plaza, gate, or other similar facility used in connection with a transportation facility." This includes pipes and pipe systems. Therefore, those portions of Department plans that depict pipes, pipe systems, or the internal layout and structural elements of a structure owned or operated by the Department, are exempt from a public records request under Section 119.07(3)(ee), F.S.. This applies to all formats (paper, electronic, etc.), and at any phase of completion (existing, draft, preliminary, phase reviews, final). Entities or persons outside the Department requesting or receiving copies of any portion of plans considered Exempt Documents will need to complete a request form (Form No. 050-020-26). The form also advises the requestor that the entity or person receiving the information shall maintain the confidential and exempt status of the information. This procedure applies to both Department internal or contracted staff who produce such Exempt Documents in their Department work or have other methods of access to such Exempt Documents in the distribution to persons or entities outside of the Department. Refer to Topic No. 050-020-026 for further requirements.

The pdf version of these standards can be accessed on the following website:

<http://www.dot.state.fl.us/rddesign/DesignStandards/Standards.shtm>

Copies of this document can be procured by contacting the following:

FLORIDA DEPARTMENT OF TRANSPORTATION

MAPS & PUBLICATION SALES

MAIL STATION 12

605 SUWANNEE STREET

TALLAHASSEE, FLORIDA 32399-0450

Phone (850) 414-4050

Fax Number (850) 414-8036

<http://www.dot.state.fl.us/mapsandpublications/>

CERTIFICATION STATEMENT

I hereby certify that this Design Standard Book was compiled under my responsible charge from designs prepared, examined, adopted and implemented by the Florida Department of Transportation in accordance with established procedures, and as approved by the Federal Highway Administration.

*As To Structures
Design Standards Nos.*

199
289-292
302 (Sheets 2-4)
306
403
411
414
420-425
470-490
501,505
521
530
810-880
5100-5301
11200-11860
13417
17502 (Sheets 3-7)
17515
17723,17725
17743,17745
17749
20110-21930

*State Structures Design Engineer
Robert V. Robertson, Jr.
P.E. No. 36160*

Sig:

Date:

*As To Roadway
Design Standards Nos.*

001-106
200-288
293,295
300-301
302 (Sheet 1)
303-305
307-310
400-402
410
412
415,417
430
461
500
506-520
525-527
532-540
546,560
600-670
700
800-803
17302-17501
17502 (Sheets 1,2)
17504, 17505
17600,17721
177727-17736
17748
17764-17890

*State Roadway Design Engineer
David C. D'Hagan
P.E. No. 33713*

Sig:

Date:

*As To Planning
Design Standard No.
17900*

*Manager, Traffic Data Section
Transportation Statistics Office
Richard L. Reel, Jr.
P.E. No. 22400*

Sig:

Date:

*As To ITS
Design Standard Nos.
18100-18305*

*Deputy State Traffic
Operations Engineer
Mark C. Wilson
P.E. No. 46780*

Sig:

Date:

*As To Landscape
Architecture
Design Standard No.
544*

*State Transportation
Landscape Architect
Jeff H. Caster
LA0001592*

Sig:

Date:

THIS SHEET INTENDED TO BE BLANK

TABLE OF CONTENTS

REVISIONS

Revisions Sheets Since Publication Of The 2008 Booklet (5 Sheets)

ABBREVIATIONS AND SYMBOLS

001 Standard Abbreviations (3 Sheets)
002 Standard Symbols (3 Sheets)

EROSION CONTROL AND WATER QUALITY

100 Temporary Slope Drain And Sod Flume
101 Trash Retainer And Sediment Basin
102 Temporary Erosion And Sediment Control (3 Sheets)
103 Turbidity Barriers
104 Permanent Erosion Control (2 Sheets)
105 Shoulder Sodding And Turf On Existing Facilities
106 Soil Tracking Prevention Device Type A

DRAINAGE

199 Geotextile Criteria
200 Structure Bottoms—Type J And P (5 Sheets)
201 Supplementary Details For Manholes And Inlets (5 Sheets)
205 Cover Height (6 Sheets)
206 Trench Drain (2 Sheets)
210 Curb Inlet Tops—Types 1, 2, 3 And 4
211 Curb Inlet Tops—Types 5 and 6 (5 Sheets)
212 Curb Inlet—Type 7
213 Curb Inlet—Type 8
214 Curb Inlet Top—Type 9
215 Curb Inlet Top—Type 10
216 Closed Flume Inlet (3 Sheets)
217 Median Barrier Inlets Types 1, 2, 3, 4 And 5 (2 Sheets)
218 Barrier Wall Inlet (2 Sheets)
219 Barrier Wall Inlet—Barrier Wall, Concrete (Rigid) (C & G) (2 Sheets)
220 Gutter Inlet—Type S (3 Sheets)
221 Gutter Inlet—Type V (2 Sheets)
230 Ditch Bottom Inlet—Type A (2 Sheets)
231 Ditch Bottom Inlet—Type B (3 Sheets)
232 Ditch Bottom Inlets—Types C, D, E And H (7 Sheets)
233 Ditch Bottom Inlets—Types F And G (2 Sheets)
234 Ditch Bottom Inlet—Type J (2 Sheets)
235 Ditch Bottom Inlet—Type K (2 Sheets)
240 Skimmer For Outlet Control Structures (2 Sheets)
241 Skimmers For French—Drain Outlets
245 Underdrain Inspection Box
250 Straight Concrete Endwalls—Single And Multiple Pipe (2 Sheets)
251 Straight Concrete Endwalls—Single And Double 60" Pipe (2 Sheets)
252 Straight Concrete Endwalls—Single And Double 66" Pipe (2 Sheets)
253 Straight Concrete Endwalls—Single And Double 72" Pipe (2 Sheets)
255 Straight Concrete Endwall—Single 84" Pipe
258 Straight Sand—Cement Endwalls
260 U—Type Concrete Endwalls With Grates—15" To 30" Pipe
261 U—Type Concrete Endwalls—Baffles And Grate Optional—15" To 30" Pipe (3 Sheets)

DRAINAGE (CONT.)

264 U—Type Concrete Endwall—Energy Dissipator—30" To 72" Pipe (2 Sheets)
266 Winged Concrete Endwalls—Single Round Pipe
268 U—Type Sand—Cement Endwalls
270 Flared End Section
272 Cross Drain Mitered End Section (6 Sheets)
273 Side Drain Mitered End Section (7 Sheets)
280 Miscellaneous Drainage Details (3 Sheets)
281 Ditch Pavement And Sodding (2 Sheets)
282 Back Of Sidewalk Drainage (3 Sheets)
283 Median Opening Flume
284 Concrete Shoulder Gutter Spillway
285 French Drain (2 Sheets)
286 Underdrain (2 Sheets)
287 Concrete Pavement Subdrainage (4 Sheets)
288 Deep Well Injection Box
289 Concrete Box Culvert Details (LRFD) (7 Sheets)
291 Supplemental Details For Precast Concrete Box Culverts (5 Sheets)
292 Standard Precast Concrete Box Culverts (14 Sheets)
293 Safety Modifications For Inlets In Box Culverts
295 Safety Modifications For Endwalls

CURBS AND PAVEMENT JOINTS

300 Curb & Curb And Gutter (2 Sheets)
301 Turn Lanes
302 Traffic Separators (4 Sheets)
303 Curb Return Profiles
304 Public Sidewalk Curb Ramps (6 Sheets)
305 Concrete Pavement Joints (4 Sheets)
306 Bridge Approach Expansion Joint—Concrete Pavement
307 Miscellaneous Utility Details (3 Sheets)
308 Concrete Slab Replacement (2 Sheets)
310 Concrete Sidewalk (2 Sheets)

TRAFFIC RAILINGS

400 Guardrail (26 Sheets)
402 Guardrail Transitions And Connections For Existing Bridges (24 Sheets)
403 Guardrail Transitions For Existing Bridge Traffic Railing Retrofits (3 Sheets)
410 Concrete Barrier Wall (25 Sheets)
411 Pier Protection Barrier (10 Sheets)
412 Low Profile Barrier (5 Sheets)
414 Type K Temporary Concrete Barrier (15 Sheets)
415 Temporary Concrete Barrier (10 Sheets)
417 Inertial Crash Cushion
420 Traffic Railing — (32" F Shape) (3 Sheets)
421 Traffic Railing — (Median 32" F Shape) (3 Sheets)
422 Traffic Railing — (42" Vertical Shape) (3 Sheets)
423 Traffic Railing — (32" Vertical Shape) (3 Sheets)
424 Traffic Railing — (Corral Shape) (7 Sheets)
425 Traffic Railing — (42" F Shape) (3 Sheets)
430 Optional Crash Cushion Details (2 Sheets)
461 Opaque Visual Barrier

TRAFFIC RAILINGS (CONT.)

470 Traffic Railing — (Thrie Beam Retrofit) General Notes & Details (3 Sheets)
471 Traffic Railing — (Thrie Beam Retrofit) Narrow Curb (4 Sheets)
472 Traffic Railing — (Thrie Beam Retrofit) Wide Strong Curb Type 1 (4 Sheets)
473
474 Traffic Railing — (Thrie Beam Retrofit) Intermediate Curb (4 Sheets)
475 Traffic Railing — (Thrie Beam Retrofit) Wide Curb Type 1 (4 Sheets)
476 Traffic Railing — (Thrie Beam Retrofit) Wide Curb Type 2 (4 Sheets)
480 Traffic Railing — (Vertical Face Retrofit) General Notes & Details (2 Sheets)
481 Traffic Railing — (Vertical Face Retrofit) Narrow Curb (3 Sheets)
482 Traffic Railing — (Vertical Face Retrofit) Wide Curb (4 Sheets)
483 Traffic Railing — (Vertical Face Retrofit) Intermediate Curb (3 Sheets)
490

GENERAL

500 Removal Of Organic And Plastic Material (2 Sheets)
501 Geosynthetic Reinforced Soils (9 Sheets)
505 Embankment Utilization (4 Sheets)
506 Miscellaneous Earthwork Details
510 Super-elevation—Rural Highways, Urban Freeways And High Speed Urban Highways (2 Sheets)
511 Super-elevation—Urban Highways And Streets (3 Sheets)
514 Optional Base Group And Structural Numbers (2 Sheets)
515 Turnouts (7 Sheets)
516 Turnouts—Resurfacing Projects
518 Rumble Strips (3 Sheets)
520 Gravity Wall
521 Concrete Steps
525 Ramp Terminals (5 Sheets)
526 Roadway Transitions (8 Sheets)
527 Directional Median Opening (3 Sheets)
530 Rest Area Equipment (3 Sheets)
532 Mailboxes (3 Sheets)
535 Tractor Crossings
540 Settlement Plate
544 Landscape Installation (3 Sheets)
546 Sight Distance At Intersections (6 Sheets)
560 Railroad Crossings

TRAFFIC CONTROL THROUGH WORK ZONES

600 General Information For Traffic Control Through Work Zones (13 Sheets)
601 Two-Lane Two-Way, Work Outside Shoulder
602 Two-Lane Two-Way, Work On Shoulder
603 Two-Lane Two-Way, Work Within The Travel Way (2 Sheets)
604 Two-Lane Two-Way, Work In Intersection
605 Two-Lane Two-Way, Work Near Intersection
606 Two-Lane Two-Way, Work Within The Travel Way—Signal Control (4 Sheets)
607 Two-Lane Two-Way, Mobile Operation, Work On Shoulder And Work Within The Travel Way
608 Two-Lane Two-Way, Temporary Diversion Connection
611 Multilane, Work Outside Shoulder
612 Multilane, Work On Shoulder
613 Multilane, Work Within The Travel Way—Median Or Outside Lane (2 Sheets)
614 Multilane, Work Within The Travel Way—Center Lane (2 Sheets)
615 Multilane, Work In Intersection

TABLE OF CONTENTS

TRAFFIC CONTROL THROUGH WORK ZONES (CONT.)

616	Multilane, Work Near Intersection-Median Or Outside Lane (3 Sheets)
617	Multilane, Work In Intersection-Center Lane
618	Multilane, Work In Intersection-Two Lanes Closed-45 MPH Or Less
619	Multilane, Mobile Operations Work On Shoulder, Work Within Travel Way
620	Multilane Divided, Temporary Diversion Connection (2 Sheets)
621	Multilane Undivided, Temporary Diversion Connection
622	Multilane, Work Near Intersection-Temporary Diversion Connection -35 MPH or Less
625	Temporary Road Closure-5 Minutes Or Less
628	Two Way Left Turn Lane Closure
630	Crossover For Paving Train Operations, Rural (2 Sheets)
631	Temporary Crossover (2 Sheets)
635	Work In Vicinity Of Railroad Crossing
640	Converting Two-Lanes To Four-Lanes Divided, Rural (2 Sheets)
641	Converting Two-Lanes To Four-Lanes Divided, Urban (3 Sheets)
642	Transitions For Temporary Concrete Barrier Wall On Freeway Facilities
650	Two-Lane Two-Way, Rural Structure Replacement (2 Sheets)
651	Multilane Divided, Maintenance And Construction (2 Sheets)
655	Traffic Pacing (3 Sheets)
660	Pedestrian Control For Closure Of Sidewalks
665	Limited Access, Temporary Opening
667	Toll Plaza, Traffic Control Standards (6 Sheets)
670	Motorist Awareness System

ROADSIDE OFFSETS

700	Roadside Offsets (2 Sheets)
-----	-----------------------------

FENCING AND PEDESTRIAN RAILINGS

800	Fence Location (2 Sheets)
801	Fence-Type A (3 Sheets)
802	Fence-Type B (3 Sheets)
803	Cantilever Slide Gate-Type B Fence
810	Bridge Fencing (Vertical) (4 Sheets)
811	Bridge Fencing (Curved Top) (3 Sheets)
812	Bridge Fencing (Enclosed) (4 Sheets)
820	Pedestrian/Bicycle Railing
821	Aluminum Pedestrian/Bicycle Bullet Railing For Traffic Railing (32" F Shape)
822	Aluminum Pedestrian/Bicycle Bullet Railing Details (2 Sheets)
850	Steel Pedestrian/Bicycle Picket Railing (5 Sheets)
851	Bridge Pedestrian/Bicycle Picket Railing (Steel) (2 Sheets)
860	Aluminum Pedestrian/Bicycle Picket Railing (5 Sheets)
861	Bridge Pedestrian/Bicycle Picket Railing (Aluminum) (2 Sheets)
870	Aluminum Pipe Guiderail (5 Sheets)
880	Steel Pipe Guiderail (5 Sheets)

WALL AND SOUND BARRIER SYSTEMS

5100	Retaining Wall-Cast In Place (2 Sheets)
5200	Precast Sound Barriers-General Notes
5201	Precast Sound Barriers-Texture Options
5202	Precast Sound Barriers-Flush Panel Option (4 Sheets)
5203	Precast Sound Barriers-Recessed Panel Option (5 Sheets)
5204	Precast Sound Barriers-Fire Hose Access Hole & Drainage Details
5205	Precast Sound Barriers-Pile and Post Reinforcing Steel (7 Sheets)
5206	Precast Sound Barriers-Pile Depth and Reinforcing Summary
5207	Precast Sound Barriers-Precast Post Capital
5210	Traffic Railing/Sound Barrier (8'-0") (5 Sheets)
5211	Traffic Railing/Sound Barrier (14'-0") (3 Sheets)
5212	Traffic Railing/Sound Barrier (8'-0") Junction Slab (2 Sheets)
5213	Traffic Railing/Sound Barrier T-Shape Spread Footing (2 Sheets)
5214	Traffic Railing/Sound Barrier L-Shaped Spread Footing (4 Sheets)
5215	Traffic Railing/Sound Barrier Trench Footing
5300	Permanent Retaining Wall Systems (19 Sheets)
5301	Temporary Retaining Wall Systems

SIGNING AND MARKINGS

11200	Multi-Column Ground Sign (2 Sheets)
11300	Steel Overhead Sign Structures
11310	Cantilever Sign Structure (5 Sheets)
11320	Span Sign Structure (5 Sheets)
11860	Single Column Ground Signs (8 Sheets)
13417	Mounting Exit Numbering Panels To Highway Signs
17302	Typical Sections For Placement Of Single & Multi-Column Signs
17328	Typical Signing For Truck Weigh & Inspection Stations (2 Sheets)
17344	School Signs & Markings (6 Sheets)
17345	Interchange Markings (4 Sheets)
17346	Special Marking Areas (14 Sheets)
17347	Bicycle Markings (4 Sheets)
17349	Traffic Controls For Street Terminations
17350	Signing For Motorist Services
17351	Welcome Center Signing (2 Sheets)
17352	Typical Placement Of Reflective Pavement Markers (2 Sheets)
17355	Special Sign Details (11 Sheets)
17356	Span Wire Mounted Sign Details
17357	Bridge Weight Restrictions
17359	Rural Narrow Bridge Treatment (2 Sheets)

ROADWAY LIGHTING

17500	Conventional Lighting (3 Sheets)
17501	Highway Lighting General Notes
17502	Highmast Lighting (7 Sheets)
17504	Service Point Details
17505	External Lighting For Signs (2 Sheets)
17515	Standard Roadway Aluminum Lighting (8 Sheets)

TRAFFIC SIGNAL AND EQUIPMENT

17600	Motorist Aid Call Box (3 Sheets)
17721	Conduit Installation Details (2 Sheets)
17723	Steel Strain Pole (3 Sheets)
17725	Concrete Poles (2 Sheets)
17727	Signal Cable And Span Wire Installation Details (2 Sheets)
17733	Aerial Interconnect
17736	Electric Power Service
17743	Standard Mast Arm Assemblies (3 Sheets)
17745	Mast Arm Assemblies (5 Sheets)
17748	Free-Swinging, Internally-Illuminated Street Sign Assemblies
17749	Damping Device For Miscellaneous Structures
17764	Pedestrian Control Signal Installation Details
17781	Vehicle Loop Installation Details (2 Sheets)
17784	Pedestrian Detector Assembly Installation Details (2 Sheets)
17841	Cabinet Installation Details
17870	Standard Signal Operating Plans (2 Sheets)
17881	Advance Warning For R/R Crossing
17882	Railroad Grade Crossing Traffic Control Devices (4 Sheets)
17890	Traffic Control Devices For Movable Span Bridge Signals (3 Sheets)

MISCELLANEOUS

17900	Traffic Monitoring Site (7 Sheets)
-------	------------------------------------

ITS

18100	CCTV Pole Placement
18101	Typical CCTV Site
18102	CCTV Pole Grounding (2 Sheets)
18104	CCTV Cabinet Equipment Layout
18105	CCTV Block Diagram
18107	Ground Mounted CCTV Cabinet
18108	Pole Mounted CCTV Cabinet
18110	Camera Mounting Details (2 Sheets)
18111	Steel CCTV Pole (2 Sheets)
18113	Concrete CCTV Pole (2 Sheets)
18202	Fiber Optic Pullbox And Trench Details
18204	Fiber Optic Splice Box And Pullbox
18300	DMS Cabinet And Sign Wiring And Block Diagram
18301	DMS Cabinet Layout
18302	Typical DMS Mounting Details
18303	DMS Structures Details (2 Sheets)
18305	DMS Grounding Details (2 Sheets)

TABLE OF CONTENTS

PRESTRESSED CONCRETE AASHTO BEAMS

- 20110 Typical AASHTO And Bulb-T Beam Details and Notes
- 20120 AASHTO Type II-Beam Standard Details
- 20130 AASHTO Type III Beam - Standard Details
- 20140 AASHTO Type IV Beam - Standard Details
- 20150 AASHTO Type V Beam - Standard Details
- 20160 AASHTO Type VI Beam - Standard Details
- 20172 Florida Bulb-T 72 Beam - Standard Details
- 20178 Florida Bulb-T 78 Beam - Standard Details
- 20199 Build-Up And Deflection Data For AASHTO And Bulb-T Beams

PRESTRESSED CONCRETE FLORIDA U BEAMS (FUB)

- 20210 Typical Florida U Beam Details And Notes (2 Sheets)
- 20248 Florida U 48 Beam - Standard Details (3 Sheets)
- 20254 Florida U 54 Beam - Standard Details (3 Sheets)
- 20263 Florida U 63 Beam - Standard Details (3 Sheets)
- 20272 Florida U 72 Beam - Standard Details (3 Sheets)
- 20299 Build-Up And Deflection Data For Florida U Beams

PRESTRESSED CONCRETE INVERTED-T BEAMS

- 20310 Typical Inverted-T Beam Details And Notes
- 20320 Inverted-T Beam Standard Details

CONCRETE SHEET PILES

- 20400 Notes And Details For Precast Concrete Sheet Piles
- 20410 Precast Concrete Sheet Pile Type "A" - 10 Inch Thick
- 20412 Precast Concrete Sheet Pile Type "A" - 12 Inch Thick
- 20430 Precast Concrete Sheet Pile Type "B" - Variable Angle Corner Pile
- 20440 Precast Concrete Sheet Pile Type "C" - Right Angle Corner Pile

BEARING PADS

- 20500 Composite Elastomeric Bearing Pads
- 20501 Beveled Bearing Plate Details-Prestressed AASHTO And Bulb-T Beams
- 20502 Beveled Bearing Plate Details-Florida U-Beams

SQUARE AND ROUND CONCRETE PILES

- 20600 Notes And Details For Square Prestressed Concrete Piles
- 20601 Square Prestressed Concrete Pile Splices
- 20602 EDC Instrumentation For Square Prestressed Concrete Piles
- 20612 12" Square Prestressed Concrete Pile
- 20614 14" Square Prestressed Concrete Pile
- 20618 18" Square Prestressed Concrete Pile
- 20620 20" Square Prestressed Concrete Pile
- 20624 24" Square Prestressed Concrete Pile
- 20630 30" Square Prestressed Concrete Pile
- 20631 High Moment Capacity 30" Square Prestressed Concrete Pile
- 20654 54" Precast/Post-Tensioned Concrete Cylinder Pile (2 Sheets)
- 20660 60" Prestressed Concrete Cylinder Pile (2 Sheets)

APPROACH SLABS

- 20900 Approach Slabs (Flexible Pavement Approaches) (2 Sheets)
- 20910 Approach Slabs (Rigid Pavement Approaches) (2 Sheets)

BRIDGE EXPANSION JOINTS

- 21100 Strip Seal Expansion Joint (3 Sheets)
- 21110 Poured joint With Backer Rod Expansion Joint System (2 Sheets)

STRUCTURES LIGHTING AND UTILITIES

- 21200 Light Pole Pilaster (2 Sheets)
- 21210 Utility Conduit Details (2 Sheets)
- 21220 Navigation Light System Details (Fixed Bridges) (2 Sheets)
- 21240 Maintenance Lighting For Box Girders (2 Sheets)

STANDARD BAR BENDING DETAILS

- 21300 Standard Bar Bending Details

TEMPORARY DETOUR BRIDGES

- 21600 Temporary Detour Bridge General Notes And Details (7 Sheets)
- 21610 Temporary Detour Bridge Details-Timber Pile Foundations (3 Sheets)
- 21620 Temporary Detour Bridge Details-Steel H Pile Foundations (2 Sheets)
- 21630 Temporary Detour Bridge Details-Steel Pipe Pile Foundations (3 Sheets)

POST-TENSIONING DETAILS

- 21801 Post-Tensioning Vertical Profiles (2 Sheets)
- 21802 Post-Tensioning Anchorage Protection
- 21803 Post-Tensioning Anchorage And Grouting Details (3 Sheets)

FENDER SYSTEMS DETAILS

- 21900 Fender System General Notes And Layout (2 Sheets)
- 21910 Fender System Heavy Duty (5 Sheets)
- 21920 Fender System Medium Duty (5 Sheets)
- 21930 Fender System Light Duty (5 Sheets)

**Revisions
Design Standards 2010**

Index Number	Sheet Number	Description	Index Number	Sheet Number	Description
001	1 thru 3	Added the following standard abbreviations: B Base Line, Base Line Control F Flow Line GRI Geosynthetic Research Institute HDPE High Density Polyethylene NPS Nominal Pipe Size Deleted the following standard abbreviations: Bbl Barrel FRCP Fiber Reinforced Concrete Pipe FRP Fiber Reinforced Pipe FS Far Side	233	1 thru 2	Index was expanded due to font size change.
			234	1 thru 2	Index was expanded due to font size change.
				2 of 2	Under Pavement & Sodding detail changed "1/2" Exp. Joint" to "1/2" Preformed Joint Filler".
			235	1 of 2	"GENERAL NOTES", Note 3, deleted "Alternate B" replaced with "Index 200"; Note 8 changed "Specification Section 962" to "Specification Section 975".
			245	1 of 1	"GENERAL NOTES" Note 2, delete and replace with the following: "Concrete shall be Class I (Structural), except ASTM C478 (4000 psi) concrete may be substituted for precast items manufactured in plants meeting the requirements of Section 449 of the Specifications. Box shall be reinforced with No. 3 bars (Grade 60) on 8" centers both ways, sides and bottom.
002	2 of 3	Deleted Hand Drafting Symbols	250	1 of 2	"GENERAL NOTES" Note 5, deleted and replaced with the following: "Concrete shall be Class I (Structural), except ASTM C478 (4000 psi) concrete may be substituted for precast items manufactured in plants meeting the requirements of Section 449 of the Specifications."
102	2 of 3	NOTES FOR SYNTHETIC BALES OR BALE TYPE BARRIERS, Note 2, deleted the text "trenched 3" to 4" and" from the first sentence.	251	1 of 2	"GENERAL NOTES" Note 4, deleted and replaced with the following: "Concrete shall be Class II, except ASTM C478 (4000 psi) concrete may be substituted for precast items manufactured in plants meeting the requirements of Section 449 of the Specifications."
104	2 of 2	RURAL DIVIDED detail, changed "5' Shoulder Pavement" to "4' Shoulder Pavement".	252	1 of 2	"GENERAL NOTES" Note 4, deleted and replaced with the following: "Concrete shall be Class II, except ASTM C478 (4000 psi) concrete may be substituted for precast items manufactured in plants meeting the requirements of Section 449 of the Specifications."
105	1 of 1	TREATMENT I, Criteria for using Treatment I, replaced text of the last bullet with the following: "resurfacing build-up is less than 3" "	253	1 of 2	"GENERAL NOTES" Note 4, deleted and replaced with the following: "Concrete shall be Class II, except ASTM C478 (4000 psi) concrete may be substituted for precast items manufactured in plants meeting the requirements of Section 449 of the Specifications."
200	1 of 5	TOP SLAB REINFORCING STEEL DIAGRAM (ALTERNATE B) to the notes "2 Additional Bars A @ 5" O.C." and "2 Additional Bars B @ 5" Max. O.C. Each Side Of Opening", added "(Minimum #4 Bars)".	255	1 of 2	"GENERAL NOTES" Note 4, deleted and replaced with the following: "Concrete shall be Class II, except ASTM C478 (4000 psi) concrete may be substituted for precast items manufactured in plants meeting the requirements of Section 449 of the Specifications."
	2 of 5	Note 9, Delete second sentence and substitute, "Additional bars used to restrain hole formers for precast structures with grouted pipe connections, may be left flush with the hole surface."	260	1 of 1	"GENERAL NOTES" Note 3 changed "Specification Section 962" to "Specification Section 975".
	4 of 5	SLAB AND WALL DESIGN TABLE NOTES, added the following to the end of Note 10: "See Index No. 201, Sheet 4 for allowable bar spacing adjustments when larger areas of reinforcing are substituted."	261	1 of 3	"GENERAL NOTES" Note 4 changed "Specification Section 962" to "Specification Section 975".
201	4 of 5	"Revised title of notes to ""NOTES FOR PRECAST OPTIONS AND EQUIVALENT REINFORCEMENT SUBSTITUTION"" and added the following to Note 4, ""When an increased area of reinforcing is provided, then the maximum bar spacing may be increased by the squared ratio of increased steel area, but not to exceed 12 inches: Max. Bar Spacing Provided < Max. Bar Spacing Required x (Steel Area Provided/Min. Steel Area Required) ² "	264	1 thru 2	Index was expanded due to font size change. General note 3 changed.
205	1 of 6	Changed maximum size of allowed PVC pipe to 36".	270	1 of 1	"GENERAL NOTES" Note 2 changed "Specification Section 941-1.5" to "Specification Section 449". Changed Note 3.
	2 of 6	ROUND PIPE DIMENSIONS, deleted the column, "Wall Thickness (In.) Class III" and subcolumn "NRCHP" and heading "SRCP". Also deleted the ** note at the bottom of the table.	272	6 of 6	Reordered "GENERAL NOTES" and changed "Class I concrete" to "Class NS concrete".
	3 of 6	NOTES: deleted note 4; table "PIPE ARCH: SPIRAL RIB: 3/4" x 3/4" x 7 1/2" RIB SPACING..." deleted references to note 4; table "ROUND PIPE - SPIRAL RIB", "Maximum Height of Fill (Ft.)", "Sheet Thickness In Inches (Gage)", "0.138 (10)" added measurements.	273	1 thru 7	Index was expanded due to font size change.
210	1 of 1	Delete General Note 4, and substitute the following: "For precast units the rear wall and apron may be precast as a separate piece from the top slab. Provide a minimum of 7 ~ #4 dowels in accordance with Index No. 201 "OPTIONAL CONSTRUCTION JOINTS".		7 of 7	"GENERAL NOTES", Note 8, deleted "Class I concrete" and substituted "Class NS concrete".
211	1 thru 5	Revised index completely 3 sheets added, Reinforcing configuration and C.I.P. details revised; precast and WWR details added. Changed Note 4 to allow 4'-0" round risers.	280	1 thru 3	Index was expanded due to font size change.
213	1 of 1	In PLAN view changed "1/2" Exp. Joint (Typ)" to "1/2" Preformed Joint Filler (Typ)".		1 of 3	"DISSIMILAR TYPES CONCRETE JACKET FOR CONNECTING DISSIMILAR TYPES OF PIPE AND CONCRETE PIPES WITH DISSIMILAR JOINTS" detail, added the note, "Alternate connection must be approved by the State Drainage Engineer."
218	2 of 2	"STEEL GRATE", "TOP VIEW", for the overall dimension on the left side of the grate, inserted "44 1/4" ". For the small dimension at the upper left corner of the grate, inserted "3 1/2" ".	282	1 thru 3	Index was expanded due to font size change.
219	1 of 2	In PLAN view and Section HH changed "Expansion Joint (Typ)" and "Expansion Material Joint" to "1/2" Preformed Joint Filler (Typ)".		1 of 3	"FRONT ELEVATION" and "SECTION AA" details changed "1/2" Exp. Matl. " to "1/2" Preformed Joint Filler".
220	1 of 3	"GUTTER INLET TYPE S", "SECTION BB", Changed the vertical dimension between the top of the inlet and the grate elevation from "5 1/2" to "4 1/2" ". "SECTION AA", at the top right corner, for precast thickness changed " 6" " to " 3" " (same as left side). "SECTION BB", at the top, changed "3'-11" Precast" to " 4'-3" Precast". "PLAN", at the top, changed " 3'-11" Precast to " 4'-3" Precast".	284	2 of 3	"PLAN" and "SECTION AA" details changed "1/2" Exp. Matl. " to "1/2" Preformed Joint Filler".
			287	1 of 1	Deleted note "1" and substituted the following: "1. Spillway to be paid for as Shoulder Gutter, LF." Deleted note "2", and substituted the following: "2. If spillway empties into an unpaved ditch the detail should be modified as necessary."
			288	1 thru 4	Sheet 3 is new. Renumbered other sheets.
			289	1 of 4	Changed all 3 occurrences of "Class I concrete" to "Class NS concrete".
230	1 of 2	In "PLAN" view changed "1/2" Exp. Joint (typ)" to "1/2" Preformed Joint Filler (Typ)". Section E-E, Changed 4Z15.9 shape to built up section (3.5 x 3 x 1/2L + 1/2 x 3 Bar) for grating.	288	1 of 1	New Index added "DEEP WELL INJECTION BDX".
231	1 of 3	"DITCH BOTTOM INLET TYPE B", "SECTION BB", upper left side, deleted the dimension "2'-6" (Min.)" and replaced with "1'-10" (Min.)".	289	6 of 7	Changed "FLARED ENDWALL" to "FLARED WINGWALL" and "STRAIGHT ENDWALL" to "STRAIGHT WINGWALL".
232	1 thru 7	Index was expanded due to font size change.	291	1 of 5	Changed "Class I Concrete" to "Class NS".
				5 of 5	Changed "Bond Beam" to "Link Slab", and "Class I Concrete" to "Class NS".
			292	2 of 14	"GENERAL NOTES" note 1, changed AASHTO LRFD Bridge Specifications, to "4th Edition"; added note 10.

**Revisions
Design Standards 2010**

Index Number	Sheet Number	Description	Index Number	Sheet Number	Description
295	1 of 1	"GENERAL NOTES" Note 2 changed "Specification Section 962" to "Specification Section 975".	421	1 of 3	Changed REFLECTIVE RAILING MARKERS note, "Reflective Railing Markers shall meet Specification Section 993. Install markers on top of the Traffic Railing along the centerline at the spacing shown in the table above. Reflector color (white or yellow) shall match the color of the near edgeline. The cost of the reflective markers shall be included in the Contract Unit Price for the Traffic Railing."
300	1 thru 2	Index was expanded due to change in font.			
304	6 of 6	Added alternate location of detectable warnings on linear ramps. Added note "On curb ramps, landings and flush transitions perpendicular to the curb line: Rows of domes shall be aligned with the centerline of the ramp. (See Pictorial View A)" at top of sheet. Added Rail Road Crossing PLAN view.	422	1 of 3	Added the following to the NAME, DATE AND BRIDGE NUMBER note: "The Name shall be as shown in the General Notes in the Structures Plans."; Changed REFLECTIVE RAILING MARKERS note.
305	1 & 4 of 4	Deleted bar spacing table and revised notes (Sheet 1); Changed width of outside lanes (Sheet 4).			Changed REFLECTIVE RAILING MARKERS note, "Reflective Railing Markers shall meet Specification Section 993. Install markers on top of the Traffic Railing 2" from the face on the traffic side at the spacing shown in the table above. Reflector color (white or yellow) shall match the color of the near edgeline. The cost of the reflective markers shall be included in the Contract Unit Price for the Traffic Railing."
307	2 of 3	"UTILITY CONFLICT PIPES THRU STORM SEWER STRUCTURES" changed to "UTILITY CONFLICT PIPES THRU STORM DRAIN STRUCTURES"			
310	1 of 2	"SIDEWALK WITH EDGE BEAM FOR SURFACE MOUNTED RAILINGS", "Clear Width", deleted "3' Min." and substituted "4' Min. *".	423	1 of 3	Added the following to the NAME, DATE AND BRIDGE NUMBER note: "The Name shall be as shown in the General Notes in the Structures Plans."; Bicycle Railing to "Special Height Bicycle Railing" and Post "B" to Post "B1".
		"NOTES FOR CONCRETE SIDEWALK ON CURBED ROADWAYS", deleted "Note 1", and substituted the following: "1. Sidewalks shall be constructed in accordance with Section 522 of the FDOT Standard Specifications. Public sidewalk curb ramps shall include detectable warnings and be constructed in accordance with Index No. 304. Detectable warnings are not required where sidewalks intersect urban flared turnouts."			"TRAFFIC RAILING-(32" VERTICAL SHAPE)", deleted the "REFLECTIVE RAILING MARKERS" note and substituted the following: "Reflective Railing Markers shall meet Specification Section 993. Install markers on top of the Traffic Railing 2" from the face on the traffic side at the spacing shown in the table above. Reflector color (white or yellow) shall match the color of the near edgeline. The cost of the reflective markers shall be included in the Contract Unit Price for the Traffic Railing."
		"Note 3" , deleted.		2 of 3	Changed Bicycle Railing to "Special Height Bicycle Railing" and Post "B" to Post "B1".
	2 of 2	"NOTES FOR CONCRETE SIDEWALKS ON UNCURBED ROADWAYS", Changed Note 2 to "Provide detectable warnings that extend the fullwidth of the sidewalk and 24" deep from the edge of pavement where sidewalks adjoin the following vehicular ways: side roads and streets driveways with signalized entrances driveways with entrance volumes greater than 600 vpd driveways with entrance speeds of 25 mph or greater right in - right out composite driveways.		3 of 3	Changed 83 degrees to 93 degrees in CONVENTIONAL REINFORCING STEEL BENDING DIAGRAM Cross-slope table.
400	1 thru 26	Index expanded by one sheet due to font size change and added new sheet 2, "APPROACH END ANCHORAGE DETAILS", Index renumbered.	424	1 of 7	Added the following to the NAME, DATE AND BRIDGE NUMBER note: "The Name shall be as shown in the General Notes in the Structures Plans."
	1 of 26	"GENERAL NOTES" Note 17 changed "Specification Section 971" to "Specification Section 975".	425	1 of 3	"TRAFFIC RAILING - (CORRAL SHAPE)", deleted the "REFLECTIVE RAILING MARKERS" note and substituted the following: "Reflective Railing Markers shall meet Specification Section 993. Install markers on top of the Traffic Railing 2" from the face on the traffic side at the spacing shown in the table above. Reflector color (white or yellow) shall match the color of the near edgeline. The cost of the reflective markers shall be included in the Contract Unit Price for the Traffic Railing."
	2 of 26	New sheet added showing limits of pay for guardrail, details of shoulder treatment and miscellaneous asphalt for guardrail approach end treatments.			Added the following to the NAME, DATE AND BRIDGE NUMBER note: "The Name shall be as shown in the General Notes in the Structures Plans."
	3 of 26	Corrected spelling of guardrail in last paragraph.			"TRAFFIC RAILING - (42" F SHAPE)", added the following note: "REFLECTIVE RAILING MARKERS: Reflective Railing Markers shall meet Specification Section 993. Install markers on top of the Traffic Railing 2" from the face on the traffic side at the spacing shown in the table above. Reflector color (white or yellow) shall match the color of the near edgeline. The cost of the reflective markers shall be included in the Contract Unit Price for the Traffic Railing."
	15 of 26	"LOCATIONS ON FRONT SLOPES", deleted the details for guardrail on slope and rubrail termination and the chart for lateral placement on slopes. (See sheet 26)			
	16 of 26	Deleted "REFLECTORS- DETAIL M" (See sheet 17)			
	26 of 26	Added "GUARDRAIL ON SLOPES", details for guardrail on slope and rubrail termination and the chart for lateral placement on slopes.	470	1 of 3	Added Field testing proof loads to the ADHESIVE BONDED ANCHORS AND DWELS note; "TRAFFIC RAILING-(THRIE BEAM RETROFIT) GENERAL NOTES & DETAILS", deleted the "BRIDGE NAME PLATE" note and substituted the following: "If a portion of the existing Traffic Railing is to be removed that carries the bridge name, number and or date, or if the installation of the Traffic Railing (Thrie Beam Retrofit) will obscure the bridge name, number and or date, then replace the information that has been removed or obscured, with 3" tall black lettering on white nonreflective sheeting applied to the top of the adjacent guardrail. The information must be clearly visible from the right side of the approaching travel lane. The sheeting and adhesive backing shall comply with Specification Section 994 and may comprise of individual decals of letters and numbers."
410	1 thru 25	Index completely revised and reorganized.			
411	2 of 10	Changed tangent offsets In Detail 'A' to "2.49'-Design Speed ≤45 mph; 1.76' - Design Speed ≥50 mph".			
	4 of 10	Changed tangent offsets In Detail 'B' to "2.49'-Design Speed ≤45 mph; 1.76' - Design Speed ≥50 mph".			
414	1 of 15	Updated Specification reference Section 971 to 975; Added steel option to ALTERNATE DESIGN note.			
	5 of 15	Added PTFE tape option to anchor bolt details.			
415	4 of 10	"NOTES FOR WALL END SHIELDING", Note 1, changed the second sentence to: "Except where the plans designate a particular type crash cushion for a specific location, the contractor has the option to construct any of the redirective crash cushions listed on the Qualified Products List, subject to the uses and limitations described on their respective drawings."		3 of 3	Added the following note: "NEOPRENE PADS: Neoprene pads must be plain pads with a durometer hardness of 60 or 70 and meet the requirements of Specification Section 932, except that testing of the finished pad will not be required."
		"ANCHOR PLATE BDLTS", upper note, changed "?" to "3/4"."	471	2 of 4	Changed offset of 7/8" dia. anchor bolts to 2 3/4" from back edge of base plate in SECTION B-B.
420	1 of 3	Added the following to the NAME, DATE AND BRIDGE NUMBER note: "The Name shall be as shown in the General Notes in the Structures Plans."; Changed REFLECTIVE RAILING MARKERS note.	472	2 of 4	"SECTION A-A" and "SECTION B-B", changed "Resilient Pad" to "Neoprene Pad".
		Changed REFLECTIVE RAILING MARKERS note, "Reflective Railing Markers shall meet Specification Section 993. Install markers on top of the Traffic Railing 2" from the face on the traffic side at the spacing shown in the table above. Reflector color (white or yellow) shall match the color of the near edgeline. The cost of the reflective markers shall be included in the Contract Unit Price for the Traffic Railing."	473	2 of 4	"SECTION A-A" and "SECTION B-B", changed "Resilient Pad" to "Neoprene Pad".
			474	2 of 4	"SECTION A-A" and "SECTION B-B", changed "Resilient Pad" to "Neoprene Pad".
				4 of 4	"SECTION C-C", changed "Resilient Pad" to "Neoprene Pad".

**Revisions
Design Standards 2010**

Index Number	Sheet Number	Description	Index Number	Sheet Number	Description
475	2 of 4	"SECTION A-A" and "SECTION B-B", changed "Resilient Pad" to "Neoprene Pad".	600	3 of 13	LANE WIDTHS, in the second sentence, change the word "expected" to "excepted".
476	2 of 4	"SECTION A-A" and "SECTION B-B", changed "Resilient Pad" to "Neoprene Pad".		5 of 13	Changed note under "SIGN COVERING AND INTERMITTENT WORK STOPPAGE SIGNING"; added information for the use of the new "PROJECT INFORMATION SIGN".
480	1 of 2	"TRAFFIC RAILING-(VERTICAL FACE RETROFIT) GENERAL NOTES & DETAILS", added the following to the "ADHESIVE-BONDED ANCHORS AND DOWELS" note, "The field testing proof loads required by Specification Section 416 shall be 23,800 lbs. for Dowel Bars 6D on the inside face (traffic side) of the railing (1'-0" embedment) and 18,500 lbs for Dowel Bars 6D along the outside face of the traffic railing (5" min. embedment)." Added NEOPRENE PADS note. Also deleted the "REFLECTIVE RAILING MARKERS" note and substituted the following: "Reflective Railing Markers shall meet Specification Section 993. Install markers on top of the Traffic Railing 2" from the face on the traffic side at the spacing shown in the table below. Reflector color (white or yellow) shall match the color of the near edgeline."		6 of 13	GENERAL NOTES, deleted note 1, substituted the following: "1. All signs shall be post mounted when work operations exceed one day except for: a) Road closure signs mounted in accordance with the vendor drawing for the Type III Barricade shown on the QPL. b) Pedestrian advanced warning or regulatory signs mounted on sign supports shown on the QPL." "2 POST SIGN SUPPORT MOUNTING DETAILS", updated text to include a tolerance between sign supports. Insert "+/- 3" " after "1'-6" " and insert "+/- 6" " after "2'-6" " . POST AND FOUNDATION TABLE FOR WORK ZONE SIGNS, expanded Note 2 by adding: "unless otherwise specified in the vendor drawing on the QPL."
	2 of 2	CONVENTIONAL REINFORCING STEEL BENDING DIAGRAM, added Bars 5E, 5F and 4G for Index No. 484			POST MOUNTED SIGN NOTES, added new notes 1 and 12.
484	1-10 of 10	New Index added TRAFFIC RAILING (VERTICAL FACE RETROFIT) SPREAD FOOTING APPROACH		7 of 13	Added new sheet showing Project Information Sign and renumbered index.
500	2 of 2	"HALF SECTION" detail, deleted "Storm Sewer Mains" replaced with "Storm Drain Trunk Lines"			
501	3-9 of 9	Changed the REQUIRED TEST METHOD for Burst Strength, Soil-Geosynthetic Friction, Creep Reduction Factor & Joint Overlap to ASTM D 6706.	605	1 of 1	"GENERAL NOTES", deleted the text of "Note 8" and substituted the following: "The two channelizing devices directly in front and directly at the end of the work area may be omitted provided vehicles in the work area have high intensity rotating, flashing, oscillating or strobe lights operating." Added new heading "DURATION NOTE" and placed the following note under this heading: 1. ROAD WORK AHEAD sign may be omitted if all of the following conditions are met: a) Work operations are 60 minutes or less. b) Speed is 45 mph or less. c) No sight obstructions to vehicles approaching the work area for a distance of 600 feet. d) Vehicles in the work area have high-intensity, rotating, flashing, oscillating, or strobe lights operating. e) Volume and complexity of the roadway has been considered.
	4 of 9	Updated values for COMTRAC 70.70; Deleted AMOCD 2006, 2016 & 2044; Added GEOTEX 315ST, 2x2HF, 4x4, 3x3HF, 4x4HF & 4x6 woven geogrids.			
	5 of 9	Changed Joint Strength Overlap value to 1.2 for all Marafi products.			
	6 of 9	Deleted Application Usage 3 & 4 for SYNTEEN SF 11 & SF 12.			
	7 of 9	Added Fornir 20			
	8 of 9	Changed Creep Resistance and Creep Reduction Factors for TENSAR BX 1120, BX 1200, BX 1220 & BX 1500			
	9 of 9	Updated values for TENAX MS 220 & TENAX MS 330. Added Combigrid 30/30, Secugrid 20/20 & 30/30 extruded geogrids.	625	1 of 1	New Index added "TEMPORARY ROAD CLOSURE- 5 MINUTES OR LESS".
505	1-4 of 4	Sheet 3 is new. Renumbered other sheets.	655	1-3 of 3	New Index added "TRAFFIC PACING-LIMITED ACCESS".
515	5 of 7	In second symbolized note changed "Section 102-6" to "Section 102-8".	667	1-6 of 6	New Index added "TOLL PLAZAS".
	6 of 7	"PAVEMENT STRUCTURE FOR TURNOUTS AND AUXILLIARY LANES TABLE 515-1", "NOTES", Note 5, Deleted "Class I concrete" substituted "Class NS concrete".	801	1 of 3	"GENERAL NOTES", Note 15 and 21, deleted "Class I" and substituted "Class NS".
518	3 of 3	Revised width of rigid pavement outside travellane and changed location of rumble strip.	802	1-3 of 3	Added tolerance to ground clearance; revised Notes 7a and 7b; rearranged sheets.
520	1 of 1	"GENERAL NOTES", Note 7, Deleted "Class I Concrete (Retaining Walls)" and substituted "Class NS Concrete"		1 of 3	"GENERAL NOTES", Note 6 and 13, deleted "Class I concrete" and substituted "Class NS concrete" for all occurrences.
546	1 of 6	Added detail "PLAN", "PICTORIAL" and ** note. Index sheets reordered.	803	1 of 1	"GENERAL NOTES", Note 4, deleted both occurrences of "Class I" and substituted "Class NS".
	5 of 6	Under "NOTES FOR 4-LANE DIVIDED ROADWAY", Note 1, changed reference from "Sheet 6" to "Sheet 2".	810	2 of 4	Deleted "Section 971" and substituted "Section 975" in ANCHOR RODS, NUTS AND WASHERS note.
600	2 of 13	OVERHEAD WORK, deleted "OPTION 4 - - -" and substituted the following: OPTION 4 (OVERHEAD WORK MAINTAINING TRAFFIC WITH NO ENCRDACHMENT BELOW THE OVERHEAD WORK AREA) Traffic shall be detoured, shifted, diverted or paced as to not encroach in the area directly below the overhead work operations in accordance with the appropriate standard index drawing or detailed in the plans. This option applies to, but not limited to, the following construction activities: (a) Beam, girder and segment placement. (b) Deck form placement and removal. (c) Concrete deck placement. (d) Railing construction located at edge of deck. (e) Structure demolition. DEFINITIONS, added the following after definition of TRAVEL WAY: a. Travel Lane: The designated widths of roadway pavement marked to carry through traffic and to separate it from opposing traffic or traffic occupying other lanes. b. Auxiliary Lane: The designated widths of roadway pavement marked to separate speed change, turning, passing and climbing maneuvers from through traffic. CLEAR ZONE WIDTHS FOR WORK ZONES, deleted the text "travel" in the first sentence and substituted "traffic". Replaced chart "CLEAR ZONE WIDTHS FOR WORK ZONES".	811	3 of 3	Deleted "Section 971" and substituted "Section 975" in ANCHOR RODS, NUTS AND WASHERS note.
			812	2 of 4	Deleted "Section 971" and substituted "Section 975" in ANCHOR RODS, NUTS AND WASHERS note.
			820	1 of 1	Changed Top Rail to "Special Height Bicycle Railing" and added new Post "B2" for 3'-6" height Pedestrian/Bicycle Railing.
			821	1 of 1	Changed designation of 4'-6" tall railing to "Special Height Bicycle Railing" and added 3'-6" tall Pedestrian/Bicycle Railing.
			822	1 of 2	Changed designation of 4'-6" tall railing to "Special Height Bicycle Railing" and "Post B" to "Post B1"; Added "Post B2" details.
			850	1 of 5	Changed "Pedestrian Railing" to "Pedestrian/Bicycle Railing" and "Bicycle Railing" to "Special Height Bicycle Railing"; Added anchor bolt requirements to SHOP DRAWINGS note.
				2 of 5	Added "DETAIL FOR NON-CONTINUOUS RAILING AT CORNERS" detail. Changed Pedestrian and Bicycle Railing designation; maximum ramp length for slopes less than 6.25%; and minimum clear picket opening at post to 3/4".
				3 of 5	Changed Pedestrian and Bicycle Railing designation.
				4 of 5	Added requirement for set screw to be set flush against outside face of rail and 18-8 Alloy option in DETAILS "D" & "E", option to notch post in SECTION G-G, and 1/4" joint tolerance in DETAIL "D".
				5 of 5	Added DETAIL "F" and note (*) to ANCHOR BOLT TABLE. Changed Pedestrian and Bicycle Railing designation. Corrected height dimension on steps to top of nosing.

**Revisions
Design Standards 2010**

Index Number	Sheet Number	Description	Index Number	Sheet Number	Description
851	1 of 2	Changed Pedestrian and Bicycle Railing designation.	5204	1 of 1	Changed "Ribbed" to "Slotted" in PLUG DETAIL.
	2 of 2	Added requirement for set screw to be set flush against outside face of rail and 18-8 Alloy option in DETAIL "B". Changed field splice joint tolerance to 1/4" in DETAIL "B".	5205	1, 3, 4 & 6 of 7	Added note in Elevation Views to 'Extend post 2" above high side wall panel when post caps are shown in the plans'.
860	1 of 5	Changed "Pedestrian Railing" to "Pedestrian/Bicycle Railing" and "Bicycle Railing" to "Special Height Bicycle Railing"; Added anchor bolt requirements to SHOP DRAWINGS note. Added filler metal ER4043 to WELDING note.		2 of 7	Added tolerance between Top of Precast Collar and Auger Cast Pile; Changed "Composite Bearing Pads" to "Fiber Reinforced Bearing Pads".
	2 of 5	Added "DETAIL FOR NON-CONTINUOUS RAILING AT CORNERS" detail. Changed Pedestrian and Bicycle Railing designation; maximum ramp length for slopes less than 6.25%; and minimum clear picket opening at post to 3/4".		5 of 7	Changed "Composite Bearing Pads" to "Fiber Reinforced Bearing Pads".
	3 of 5	Changed Pedestrian and Bicycle Railing designation.	5206	7 of 7	Added "Octagonal Precast Collar" details and tolerance between Top of Precast Collar and Auger Cast Pile; Changed "Composite Bearing Pads" to "Fiber Reinforced Bearing Pads".
	4 of 5	Added requirement for set screw to be set flush against outside face of rail and 18-8 Alloy option in DETAILS "D" & "E"; option to notch post in SECTION G-G; 1/4" joint tolerance in DETAIL "D"; Type B (Nonwelded) connection detail in SECTION A-A. Changed Expansion Joint sleeve embedded length to 10" in DETAIL "D" and picket fillet weld size to 1/8", handrail and top rail fillet weld size to 1/4", and base plate fillet weld size to 3/8".	5207	1 of 1	Added "POST LENGTH WITH CAP" column, BARS D, P5 thru P8 to table and bar bending details for corner posts.
	5 of 5	Added DETAIL "F" and note (*) to ANCHOR BOLT TABLE. Changed Pedestrian and Bicycle Railing designation. Corrected height dimension on steps to top of nosing.	5210	1 of 1	New Index added "PRECAST SOUND BARRIERS-PRECAST POST CAPITAL".
861	1 of 2	Changed designation of 54" tall railing to "Special Height Bicycle Railing".	5211	2 of 5	Changed NAME, DATE AND BRIDGE NUMBER note, and "Ribbed" to "Slotted" in NEOPRENE DIAPHRAGM PLUG DETAIL. Added REFLECTIVE RAILING MARKERS note and SELECTIVE RAILING MARKER SPACING table.
	2 of 2	Added requirement for set screw to be set flush against outside face of rail and 18-8 Alloy option in DETAIL "B". Changed field splice joint tolerance to 1/4" and "Steel Sleeve" to "Aluminum Sleeve" in DETAIL "B".	5212	3 of 3	Changed "Ribbed" to "Slotted" in NEOPRENE DIAPHRAGM PLUG DETAIL. Corrected Anchor Pin diameter on FIRE HOSE ACCESS DETAIL.
870	1 of 5	Deleted Pedestrian and Bicycle designations from DESIGN LIVE LOADS and ALTERNATE DESIGN notes.	5300	2 of 2	Added note for "Full Depth Structural Asphalt" above junction slab and changed coping dimension to 6" Min.
	2 of 5	Deleted 4'-6" Bicycle Railing option and "*" note. Changed maximum ramp length for slopes less than 6.25%.		3 of 19	Increased max. gap at back of precast coping and added timber blocking.
	3 of 5	Deleted 4'-6" Bicycle Railing option.		6 of 19	Added note for "Full Depth Structural Asphalt" above junction slab and increased max. gap at back of precast coping.
	4 of 5	Added requirement for set screw to be set flush against outside face of rail and 18-8 Alloy option in DETAILS "D" & "E"; and 1/4" joint tolerance in DETAIL "D". Deleted Intermediate Rails from DETAILS "B" and "C".	11200	7 of 19	Added note for "Full Depth Structural Asphalt" above junction slab.
	5 of 5	Added DETAIL "F". Deleted 4'-6" Bicycle Railing option. Corrected height dimension on steps to top of nosing.		12 & 15 of 19	Increased max. gap at back of precast coping. Corrected size of Bar 5U1 in BILL OF REINFORCING TABLE
880	1 of 5	Deleted Pedestrian and Bicycle designations from DESIGN LIVE LOADS and ALTERNATE DESIGN notes.	11300	1-2 of 2	Deleted sheet 2
	2 of 5	Deleted 4'-6" Bicycle Railing option and "*" note. Changed maximum ramp length for slopes less than 6.25%.		1 of 2	Revised and rearranged notes, sheet renumbered to 1 of 2.
	3 of 5	Deleted 4'-6" Bicycle Railing option.	11310	2 of 2	Renumbered sheet 3 of 3 to sheet 2 of 2 revised and rearranged notes. Deleted "Class 1 (Special) Concrete" replaced with "Class 1 Concrete".
	4 of 5	Added requirement for set screw to be set flush against outside face of rail and 18-8 Alloy option in DETAILS "D" & "E"; and 1/4" joint tolerance in DETAIL "D". Deleted Intermediate Rails from DETAILS "B" and "C".	11300	1 of 1	Hanger table values revised; connection bolt size revised; sign depth for horizontal splice changed to 10'. U-Bolt material spec (A325) added to Typical Detail of Sign & Truss Connection.
	5 of 5	Added DETAIL "F". Deleted 4'-6" Bicycle Railing option. Corrected height dimension on steps to top of nosing.	11310	1 of 5	Deleted A307 bolts and Palnut (Note 4e). Changed foundation concrete (Note 7). Changed to 1/2" mesh (Note 9). Deleted grout pad and notes (former Notes 7c & 9). Added CSL tube note (Note 14).
5100	2 of 2	Changed to plastic sleeve expansion joint and "Premoulded Expansion Material" to "Preformed Joint Filler". Changed wall and expansion joint key.	11320	2 of 5	Changed foundation standoff distance and changed drilled shaft detail. Deleted grout pad and added wire screen. Added CSL tubes. Changed FC & FL reinforcing.
5200	1 of 1	Post caps added to note C.1.b; Changed note K.2 to allow 8 ft height panels. Added note K.11; Changed notes H.1, H.2 and D.2; Deleted note H.3.		5 of 5	Changed bolt spacing connection details.
5201	1 of 1	Texture Type "I" (Cut Coral Block) added.		1 of 5	Deleted A307 bolts and Palnut (Note 4e). Changed foundation concrete (Note 7). Changed to 1/2" mesh (Note 9). Deleted grout pad and notes (former Notes 7c & 9). Added CSL tube note (Note 14).
5202	1 of 4	Added precast post cap; Changed clearance tolerance on stepped panel and Neoprene Pad options.		2 of 5	Changed foundation standoff distance. Deleted grout pad and added wire screen.
	3 of 4	Changed #4 Bar Mark to Bars P5 and P6 for Pile/Post Options A, B, & E; changed Texture Thickness to 1 1/4" Max.		4 of 5	Changed bolt spacing connection details.
5203	1 of 5	Added precast post cap; Changed clearance tolerance on stepped panel and Neoprene Pad options.		5 of 5	Changed drilled shaft detail. Added CSL tubes.
	3 of 5	Changed #4 Bar Mark to Bars P5 & P6 for Pile/Post Options A, B & E, and changed texture thickness dimension to 1/4" Max.	11860	1 of 8	Changed SINGLE COLUMN GROUND SIGN NOTES, Note 11, and GUIDE TO USE THIS STANDARD, Note 4 and example. Modified concrete classification. Modified "ALUMINUM COLUMN (POST) SELECTION TABLE".
	4 of 5	New sheet added for 45 degree corner post.		2 of 8	Changed maximum limits of sign cluster area and width in NOTE.
	5 of 5	Renumbered from Sheet 4 of 4.		3 of 8	Added Aluminum Soil Plate details and notes. Changed Post and Foundation Table depth values. Modified "ALUMINUM COLUMN (POST) SELECTION TABLE".
				4 of 8	Deleted "Signs at 90°" note. Added "*" For" note. Changed number of Z-brackets for STOP and RECTANGULAR sign. Changed '1" Min.' to '0" Min.' and sign panel edge distance in VIEW A-A. Modified U-bolt size. Changed panel overhang length.
			17302	5 of 8	Modified "DRIVEN POST DETAIL IN CONCRETE".
			17328	1 of 1	CASE II, and CASE VIII dimensions and notes revised.
				1 of 1	Weigh Station and combination Weigh Station and Inspection Station signing details separated.

**Revisions
Design Standards 2010**

Index Number	Sheet Number	Description	Index Number	Sheet Number	Description
17344	2, 3, 4 & 6 of 6	SCHOOL SIGNS AND MARKINGS, on each sheet, in the Distance table at the bottom of the sheet, deleted the "A" column. Also deleted the "A" dimension from the detail drawings.	17725	1 of 2	Round pole note revised; pole height dimensions added to Type P-III through P-VIII; Copper Ground note changed.
17345	2 of 4	NORMAL TAPERED ENTRANCE WITH ADDED LANE, note in lower left corner, arrow now points to the reflective markers on the LEFT side of the ramp.		2 of 2	Notes revised and rearranged, D(feet) changed to H(feet) in both tables.
	4 of 4	Deleted note 2	17727	1-2 of 2	Schedule 40 aluminum pipe (T6061) added as an alternate to stainless steel pipe in assembly details and signalhead notes. Added backplates to signalhead details.
17346	1-14 of 14	Completely revised and renumbered.	17736	1 of 1	Added notes 5 & 6.
17347	1-4 of 4	New Index BICYCLE MARKINGS added.	17743	1 of 3	Updated assembly dimensions. Changed drilled shaft reinforcing.
17349	1 of 1	Case I and Case II revised; 18" x 18" marker detail revised; notes at bottom right revised.		2 of 3	Updated assembly dimensions. Changed drilled shaft reinforcing. Changed T3-BF.
17355	1 of 11	Revised signs FTP-9A-06 & FTP-9B-06 and notes.		3 of 3	Updated assembly dimensions. Changed drilled shaft reinforcing.
	7 of 11	For all signs with 1-800 phone number, deleted "1-800-998-RIDE" and substituted "1-8XX-XXX-XXXX" and below each sign added note: "Design Project Manager or Transit Administrator will supply correct 1-8XX number".	17745	1 of 5	QPL requirements added in new note 17; added backplates to pole detail; Notes 6 & 14 revised, deleted note 19.
	8 of 11	Revised sign FTP-68A-06, bolt holes located outside of sign message, notes revised. Sign FTP-69-06 and FTP-68B-06 message and spacing revised.	17748	2 of 5	Revised foundation reinforcing details, Section AA, Section DD and Foundation Plan details.
	9 of 11	Revised sign FTP-82-08 and arrow detail. Added Sign FTP-83-08.		1 of 1	Option 1 deleted and Options 2 and 3 renumbered; Note 1 revised. Added backplates to signalhead displays.
17356	1 of 1	Removed signalhead from detail. Single point attachment details deleted from Index. (Deleted sheet 1.)	17784	1 of 2	Dimensions revised on Figures A & B. Note 5 and Note to Designers revised.
17359	1 of 2	Changed delineators to object markers; revised reference notes; sign W13-1 made optional. RURAL NARROW BRIDGE TREATMENT, changed the DM3L on the right side of the roadways to an DM3R.	17890	2-3 of 3	Revised details and spacing for signs FTP-68A-06 and FTP-68B-06, also located bolt holes outside of sign message.
	2 of 2	Notes revised; inserts reorganized	17900	7 of 7	Added backplates to signalhead displays.
17500	1 of 3	Deleted concrete pole detail, added METAL POLE DETAIL AND WIRING DIAGRAM.	18111	1-2 of 2	Changed pole type callouts, deleted "N-III" and substituted "P-III".
	2 of 3	Note 7, deleted "class I Concrete (Miscellaneous)" replaced with "Concrete and reinforcing for slabs around poles and pullboxes shall be included in the price for pullbox or pole."	18113	1-2 of 2	Index totally revised.
	3 of 3	Note 7, deleted "class I Concrete (Miscellaneous)" replaced with "Concrete and reinforcing for slabs around poles and pullboxes shall be included in the price for pullbox or pole."	20110	1 of 1	Index totally revised.
17501	1 of 1	Deleted note 28.	20199	1 of 1	Changed Insert Detail for Diaphragm Reinforcing.
17502	3 of 7	Changed Note 9. Added Notes 10 & 11. Changed Notes 11 & 12. Deleted grout pad notes (former Notes 4 & 9). Added CSL tube note (Note 11).	20210	1 of 1	Changed BEAM CAMBER AND BUILD-UP NOTES.
	4 of 7	Added ID plate and changed base plate thickness. Deleted grout pad. Changed drilled shaft reinforcing.	20299	2 of 2	Added "Type Q" Epoxy to Note 9.
	5 of 7	Changed Weld symbol in SECTION A-A. Added padlock tab to HANDHOLE RING. Added Section E-E detail and bottom baseplate washer to SECTION C-C. Deleted grout pad and added wire screen. Added CSL tubes.	20500	1 of 1	Changed BEAM CAMBER AND BUILD-UP NOTES.
	6 of 7	Grout notes and details removed, new wire screen.	20500	1 of 1	Added Type C Pads for larger skew ranges. Changed specification of elastomer from "durometer" to "shear modulus".
	7 of 7	Note 3, changed "Concrete class" to "concrete NS"	20501	1 of 1	Changed Note 4.
17503	1 of 1	Index deleted.	20502	1 of 1	Changed Note 4.
17504	1 of 1	Dimensions 5'-6" added for height of meter base. Pole type changed from type "N" to type "P".	20602	1 of 1	Changed EDC location to 1D from tip of pile.
17505	1 of 2	Mercury Vapor Luminaires changed to Induction Luminaires. Luminaire chart deleted, dimensions revised on spacing detail note and added to structure detail.	20900	2 of 2	Changed coping width and End Bent lug from 6" to 5½" thickness.
17515	1 of 8	Added median barrier mounted light poles. Moved notes to sheet 2.	20910	2 of 2	Changed coping width and End Bent lug from 6" to 5½" thickness.
	2 of 8	New Sheet for Notes. Change Note 7 for QPL Criteria. Modified concrete classification. Added notes for median barrier mounted light pole and foundation.	21100	1 of 3	Deleted redundant notes from Specification Section 458.
	3 of 8	Sheet renumbered from 2 to 3. Added double arm configuration to ARM ELEVATION.		3 of 3	Changed Sidewalk Cover Plate edge treatment.
	4 of 8	Allowed fusion weld reinforcing cage (*) and changed foundation concrete note. Added 1" dimension to Double Nuts in FOUNDATION. Modified concrete classification. Renumbered sheet from 3 of 3 to 4 of 8.	21110	1 of 2	Deleted redundant notes from Specification Section 458. Changed last line of title of bottom left detail to "DECK WITH SLOPES 2% OR GREATER".
	5-8 of 8	New Sheets for median barrier mounted light pole.	21200	2 of 2	Changed Sidewalk Cover Plate edge treatment.
17600	2 of 3	Added detail for pole foundation to be used only behind guardrail.	21200	1 of 2	Added "Anchor Plate (dashed lines) (provide Design) to ELEVATION VIEW and TYPICAL SECTION. Added design of anchor bolts and accessories.
	3 of 3	GENERAL NOTES, note 2, changed "Class II Concrete" to "Class I Concrete"; changed note 4.		2 of 2	Added design of anchor bolts and accessories.
17723	1 of 3	Changed Note 5i, 6 and 7. Added Note 8. Deleted grout pad and notes (former Notes 4d & 7). Added CSL tube note (Note 9).	21600	1 of 7	Clarified INSTRUCTIONS TO DESIGNER for variable end span lengths.
	2 of 3	Changed number of bolts in VIEW B-B, number and size of foundation reinforcing bars, and TABLE OF STRAIN POLE VARIABLES. Added foundation standoff distance and washer for base plate. Deleted grout pad and added wire screen. Added CSL tubes. Changed drilled shaft reinforcing.	21802	3 of 7	Added vertical dimensions between deck surface and underside of bearings, including depth of Truss Panel.
	3 of 3	Changed note in VIEW E-E; Added ¼" and ⅜" cable clamps and changed weld criteria. Changed clevis size.	21803	1 of 1	Changed "Methyl Methacrylate" to "High Molecular Weight Methacrylate".
				1-2 of 3	Revised call-outs for Grout Outlets; Changed "Methyl Methacrylate" to "High Molecular Weight Methacrylate".
				3 of 3	Shrink wrap deleted from Duct Coupler Detail. Revised call-outs for Duct Couplers; Changed "Methyl Methacrylate" to "High Molecular Weight Methacrylate".

A Area or Amperes
AAA American Automobile Association
AADT Annual Average Daily Traffic
AASHTO American Association Of State Highway Officials
AASHTO American Association Of State Highway And Transportation Officials
ABC Asphalt Base Course
Abd. Abandoned
ABS Acrylonitrile-Butadiene-Styrene Pipe
AC, Ac. Acre
AC or Asph. Conc. Asphaltic Concrete
Accel. Acceleration
ACI American Concrete Institute
Act. Actuated
ADA The Americans With Disabilities Act
Adh. Adhesive
Adj. Adjust
ADT Average Daily Traffic
AFAD Automatted Flagger Assistance Device
Agg. Aggregate
Ah. Ahead
AISC American Institute Of Steel Construction
Alt. Alternate
Al. Aluminum
AM 12:00 Midnight Until 11:59 Noon
ANSI American National Standards Institute
ADS Apparent Opening Size
Appl.. Applied, Application
Apprh. Approach
Approx. Approximate
ARTBA American Road & Transportation Builders Association
Artf. Artificial
Asph. Asphalt
Assem. Assembly
Assn. Association
Assoc. Associate, Association
ASTM American Society For Testing And Materials
ATPB Asphalt Treated Permeable Base
Attn. Attention
Attnuatr. Attenuator
Aux. or Auxil. Auxiliary
Ave. Avenue
AWG American Wire Gauge
AWS American Welding Society
Az Azimuth

B to B Back to Back
Basc. Bascule
Bd. or Bnd. Bond or Bonded
BC Bottle Cap or Bolt Circle
B/C, B.C. Back Of Curb
BCCMP Bituminous Coated Corrugated Metal Pipe Culvert
BCPA Bituminous Coated Pipe Arch Culvert
BCPCMP Bituminous Coated And Paved Corrugated Metal Pipe Culvert
BCPPA Bituminous Coated And Paved Pipe Arch Culvert
BCT Breakaway Cable Terminal
BCWE Base Clearance Water Elevation
BE Buried Electric
Beg. Begin
Bit. Bituminous
Bk. Back
BL, BLC, or ☒ Base Line, Base Line Control
Bldg. Building
Blkhd. Bulkhead
BLDN Begin Length Of Need
Blvd. Boulevard
BM Bench Mark
Bndry. Boundary
Bdr. Border
Bot. Bottom
BO Basin Outlet
BOS Beginning Of Survey
BP Borrow Pit
Bq. Becquerel

Br. Bridge
Brg. Bearing
Brkwy. Breakaway
BT Buried Telephone Cable or Duct
Btfly. Butterfly
BW Barbed Wire, Bottom Width or Both Ways
C Cantilever Length, Cut, Colorless, Coulomb or Cycle Length
°C Degree Celsius
C & G Curb And Gutter
CA Coarse Aggregate
Cap. Capacity
CAP Corrugated Aluminum Pipe
Caps. Capital Letters
CASP Corrugated Aluminized Steel Pipe
CATV Cable Television
CB Catch Basin
CBC Concrete Box Culvert
CBS Concrete Box Structure
CC, C/C, C to C, or C.C. Center to Center, Crash Cushion
CCEW Center to Center Each Way
CCTV Closed-Circuit Television
CD Cross Drain, Cross Direction (Geotextiles)
cd Candela
Cem. Cement or Cemetery
Cem'd. Cemented
CFS Cubic Feet Per Second
Ch. Channel
Chchg. Channel Change
Chg. Changeable
CI Cast Iron
CIP Cast Iron Pipe
CIPL, C.I.P., C-I-P Cast In Place
circ. Circumference
Ckt. Circuit
Cl. or Clear Clearance
CL, C/L or ☒ Center Line
CM Concrete Monument
CMB Concrete Median Barrier
CMP Corrugated Metal Pipe
CMPA Corrugated Metal Pipe Arch
Co. County or Company
Col. Column
Com. Commercial or Common
CDMM Committee or By Committee
Comp. Composite
Con. Connect or Connection
Conc. Concrete
Const. Construct or Construction
Contrl. Controller
Cont. Continuation
Contr. Contractor
Coord. Coordinate
Cor. Corner
Corr. Corrugated
CP Concrete Pipe
CPE Corrugated Polyethylene Pipe
CPT Cone Penetration Test
CR Control Radius or County Road
CRA Clear Recovery Area
Crs. or Cse. Course
CS Curve To Spiral
CSP Corrugated Steel Pipe
CT Clear Trunk
CTPB Cement Treated Permeable Base
Ctivr. Cantilever
Ctr., Ctrs. Center
CU or Cu Copper
Culv. Culvert
Cwt. Hundredweight
CY, Cu. Yd., CY, or C.Y. Cubic Yard
Cyl. Cylindrical

D Degree Of Curvature, Depth, Density, Distance, Diameter or Directional Distribution
DA Drainage Area or Deflection Angle
DBH Diameter At Breast Height
DBI Ditch Bottom Inlet
Dbl. Double
DCS Degree Of Curvature (Spiral)
DD Dry Density
DDHV Directional Design Hour Traffic
Decel. Deceleration
Deg. Degree
Delin. Delineators
Demobl. Demobilization
Dept. Department
Det. Detour, Detection, Detectable
DFE Design Flood Elevation
DGN or Dgn. Design
DHV Design Hourly Volume
DHW Design High Water
DT Ditch
DI Drop Inlet
Dia. or D Diameter
Dim. Dimension
Disp. Disposal
Dist. Distance
DLS District Location Surveyor
DMM Domestic Mail Manual
DOT Department Of Transportation
DPI or D.P.I. Ditch Point Intersection
Dr. or DR. Drain, Drive or Design Review
DR Design Review
Driv. Driven
Drwy. Driveway
DS Design Speed
DSL Design Service Life
Dwg. Drawing
E East or External Distance
e Rate Of Superelevation
E to E End to End
EA or Ea. Each
EB Eastbound
EIA Electronic Industries Alliance
El. or Elev. Elevation
Elast. Elastomeric
Elec. Electric
Ellip. Elliptical
Embk. Embankment
Emul. Emulsified
Encl. Enclosure
Engr. Engineer
EOS End Of Survey or Equivalent Opening Size
E.P. or EOP Edge Of Pavement
EPDM Ethylene Propylene Diene Monomer
Eq. Equation or Equal
Equip. Equipment
Esmt. Easement
Est. or Estm. Estimate
Est. Establish or Established
Etc. or etc. Et Cetera (And So Forth)
ETP Electronic Tough Pitch
EW Endwall
Ex. Except, Example
Exc. or Excav. Excavation
Exist. Existing
Exp. Expansion
Ext. Extension
Exwy. Expressway

The abbreviations listed are the standard for contract plans production. This list is not all inclusive. Other Department accepted abbreviations may be used when deemed more appropriate. Where special abbreviations are used a descriptive tabulation may be necessary in the plans.



2010 FDOT Design Standards

STANDARD ABBREVIATIONS

Last Revision	Sheet No.
07/01/09	1 of 3
Index No.	
001	

F	Fill, Farad	HW or H.W.	High Water or Hot Water	M	Mass, Middle Ordinate Length or Mega	N m	Newton Meter
F or Final	Final Quantity	Hwy.	Highway	m	Meter or Milli	No.	Number
F & I	Furnish & Install	Hyd.	Hydraulic	m ²	Square Meter or Meter Square	Nom.	Nominal
F to F	Face to Face	Hz	Hertz	m ³	Cubic Meter or Meter Cubed	Norm.	Normal
FA	Federal Aid or Fine Aggregate			m ³ /m	Cubic Meter Per Meter	N.P.	Non Plastic
FAC	Florida Administrative Code	I	External Angle (Delta), Interstate	m/s	Meters Per Second	NPS	Nominal Pipe Size
FAP	Federal Aid Project	Intchg. or Ichg.	Interchange	Mach.	Machine	NPT	National Pipe Thread
FC	Friction Course	IES	Illuminating Engineering Society	Maint.	Maintenance	NRCP	Non-Reinforced Concrete Pipe
FD	French Drain	ID, I.D.	Inside Diameter or Identification	Matl.	Material	NS	Non Stress, Not Suitable or Near Side
Fdn.	Foundation	IMC	Intermediate Metal Conduit	Max.	Maximum	NT, N&T	Non Traffic, Nail & Tin
FDDT	Florida Department Of Transportation	In.	Inch or Inches	MB	Median Barrier	NTS	Not To Scale
FE	Floor Elevation	Inc.	Incorporated or Including	MBM	Thousand (Feet) Board Measure	NW	Northwest
Fed.	Federal	Incl. or Inc.	Included	MD	Machine Direction (Geotextiles)		
Fert.	Fertilizer	Ind.	Industry or Industrial	Med.	Median	Opass	Overpass
FES	Flared End Section	INV. or Inv.	Invert	Mega	One Million	Q to Q, o to o or O.D.	Out to Out
FETS	Flared End Terminal Section	IP	Iron Pipe	Memb.	Member	QA	Overall
FH	Fire Hydrant	Install.	Installed	MES	Mitered End Section	Q.B.G.	Optional Base Group
FHWA	Federal Highway Administration	Isect.	Intersection	Mess.	Message	QC or Q.C.	On Center
Fig.	Figure	Isl.	Island	Mfg.	Manufactured or Manufacturer	OD or O.D.	Outside Diameter
Fin.	Finish	IR	Iron Rod	MG	1000 Gallons	OE	Overhead Electric
F.L., FL or \bar{F}	Flow Line	ITE	Institute Of Transportation Engineers	MH, M.H.	Manhole, Mounting Height	OH, OHD or Ohd.	Overhead
FL, Fl. or Fla.	Florida	ITS	Intelligent Transportation Systems	MHW	Mean High Water	Opt.	Option, Optional or Optically
Flex.	Flexible			μ	Micro	OT	Overhead Telephone
FNQ	Fuse (Type Slow Burn)	J	Joule	Mi.	Mile	Oz.	Ounce
FDC	Fiber Optics Cable	JB	Junction Box	Micro	One-Millionth	Ω	Ohm
FPM or fpm	Feet Per Minute	Jct.	Junction	Mid.	Middle	P	Passenger Car & Light Delivery Truck
FPS or fps	Feet Per Second	Jt.	Joint	Mil	One-Thousandth Of An Inch	P or Plan	Plan Quantity
FR or Fr.	Frame			Mil.	Military	Pa	Pascal
Frang.	Frangible	K	Design Hour Factor or Kelvin	Milli	One-Thousandth	Par.	Parallel
Freq.	Frequency	k	Kilo (prefix)	Min.	Minimum or Minute	Pa.s	Pascal Second
F.S.	Florida Statutes	kg	Kilogram	Misc.	Miscellaneous	Part.	Participation or Partition
Ft.	Foot or Feet	kg/m	Kilogram Per Meter	mL	Milliliter	Pavt.	Pavement
FTB	Floating Turbidity Barrier	kg/m ²	Kilogram Per Square Meter	MLW	Mean Low Water	PC	Point Of Curvature
FTBA	Florida Transportation Builder Association	kg/m ³	Kilogram Per Cubic Meter	mm	Millimeter	PCBC	Precast Concrete Box Culvert
FTP	Florida Traffic Plans	Kilo	One Thousand	mobl.	Mobilization	PCC	Point Of Compound Curvature or Plain Cement Concrete
Furn.	Furnish	Kip	1000 Pounds	Mod.	Modify or Modified	PCE	Permanent Construction Easement
		km	Kilometer	Mol	Mole	PE	Professional Engineer
		km/h	Kilometer Per Hour	Mon.	Monument	Ped	Pedestrian or Pedestal
G	Giga or Gauss	kn	Knot	MOT	Maintenance Of Traffic	Pen.	Penetration
g	Gram or Gravity	kN	Kilonewton	MP	Mile Post	PG	Profile Grade
Galv.	Galvanized	kPa	Kilopascal	MPa	Megapascal	PGL	Profile Grade Line
Ga.	Gauge or Gage	ksi	Kips Per Square Inch	MPH or mph	Miles Per Hour	Ph.	Phase
Ga. or Gal.	Gallon	kV	Kilovolt	MSL	Mean Sea Level	pH	Measure Of Acidity or Alkalinity
Gar.	Garage	kVA	Kilovolt Ampere	MSTCSD	Minimum Specifications For Traffic Control Signal Devices	PI	Point Of Intersection
GD	Gutter Drain	kWh	Kilowatthour	Mtd.	Mounted	Pkg.	Parking
GFI	Ground Fault Interrupter			MUTCD	Manual On Uniform Traffic Control Device	Pkwy.	Parkway
GIP	Galvanized Iron Pipe	L	Length, Length Of Curve, Liter, Left	MUTS	Manual On Uniform Traffic Studies	PL or \bar{P}	Property Line or Plate
GM	Gas Main	2-L	Two-Lane			PM	12:00 Noon Until 11:59 Midnight
GP	Grade Point	2L1W	Two-Lane One-Way			POC	Point On Curve
Gr.	Grade, Guardrail or Grate	2L2W	Two-Lane Two-Way	N	North or Newton	PDST	Point On Semi-Tangent
Gr. or Gro.	Gross	LA or L/A	Limited Access	N/m	Newtons Per Meter	POT	Point On Tangent
GRC	Galvanized Rigid Steel Conduit	Lat.	Lateral or Latitude	N/m ²	Newtons Per Square Meter	PP	Power Pole
Grd.	Ground	Lb.	Pound	N/m ³	Newtons Per Cubic Meter	PPB	Pier Protection Barrier
GRI	Geosynthetic Research Institute	LBS.	Pounds	N/mm ²	Newtons Per Square Millimeter	Pr.	Pair
gross km	Gross Kilometer	lb/sy	Pounds Per Square Yard	NA or N/A	Not Available or Not Applicable	PRC	Point Of Reverse Curvature
Gr. Wt. or gr. wt.	Gross Weight	LBR	Limerock Bearing Ratio	N & C	Nail & Cap	Prct.	Precast
Gttr.	Gutter	LC	Long Chord	N & D	Nail & Disk	Prest.	Prestressed
		LED	Law Enforcement With Flashing Lights And Radar	NAVD	National American Vertical Datum	Prob.	Probability
H	Henry	LFD	Load Factor Design	NB	Northbound	Prod.	Product, Production, Producer or Produced
h	Hour or Hecto	Lgth.	Length	NC	National Coarse or Normal Crown	Prog.	Program or Progression
ha	Hectare	Lin.	Linear	NCHRP	National Cooperative Research Program	Proj.	Project or Projection
HAR	Highway Advisory Radio	lm	Lumen	NDCBU	Neighborhood Delivery And Collection Box Unit	PRM	Permanent Reference Monument
HB	Hay Bales	Lmrk.	Limerock	NE	Northeast	Prop.	Proposed
HC	Horizontal Clearance	LDS	Limit Of Clear Sight	net km	Net Kilometer	Prov.	Provisions
HD	High Density or Heavy Duty	Loc., LD	Location	NEMA	National Electrical Manufacturers Association	PRS	Portable Regulatory Sign
HD or Hd.	Head	Long.	Longitude	NGVD	National Geodetic Vertical Datum of 1929	PS & E	Plans, Specifications And Estimates
HDPE	High Density Polyethylene	LRFD	Load Resistance Factor Design	NGS	National Geodetic Survey	PSF or psf	Pounds Per Square Foot
Hdl.	Headwall	LS	Length Of Spiral	NHS	National Highway System	PSI or psi	Pounds Per Square Inch
HH	Heavy Hex	LT	Left Turn	NHW	Normal High Water	PT	Point Of Tangency or Pressure Treated
Hndrl	Handrail	Lt.	Left	NIC	Not In Contract	PVC	Polyvinyl Chloride
HDA	Hand/Off/Automatic	Ltd.	Lighted or Limited	NJ	New Jersey	PW	Pressure Water
Horiz. or Hor.	Horizontal	Lum.	Luminaire				
HP	High Pressure or Horsepower	L/W	Lightweight				
Hr.	Hour	lx	Lux				
HS	High Strength						
HSHV	High Strength Horizontal Vertical						
Hse.	House						
Ht.	Height						

The abbreviations listed are the standard for contract plans production. This list is not all inclusive. Other Department accepted abbreviations may be used when deemed more appropriate. Where special abbreviations are used a descriptive tabulation may be necessary in the plans.

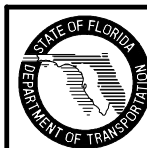

2010 FDOT Design Standards

STANDARD ABBREVIATIONS







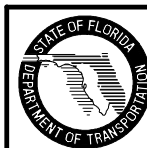



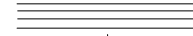

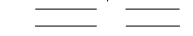
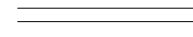

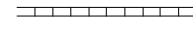
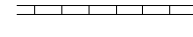

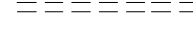
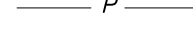
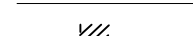

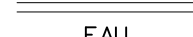

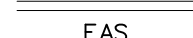
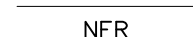
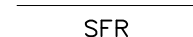
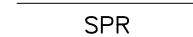

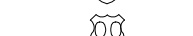
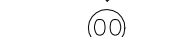
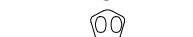



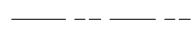
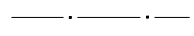
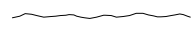
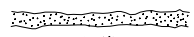







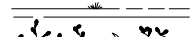
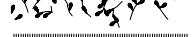





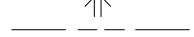
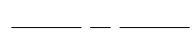

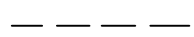
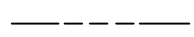



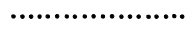
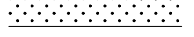
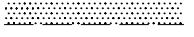
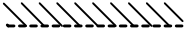
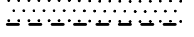
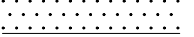





































Last Revision	Sheet No.
07/01/09	2 of 3
Index No.	
001	

				UNITS OF MEASURE	
				US MEASUREMENT	
Q	Peak Discharge or Flow Volume	SRASP	Spiral Rib Aluminized Steel Pipe	V	Volt, Velocity, Volume or Hourly Volume
QPL	Qualified Products List	SRCP	Steel Reinforced Concrete Pipe	Var.	Varies, Variable or Variance
R	Right	SRD	State Road Department	VC	Vertical Curve
R or Rad.	Radius	SRSP	Spiral Rib Steel Pipe	VCP	Vitrified Clay Pipe
R or Rng.	Range	SS	Sanitary Sewer	VECP	Value Engineering Change Proposal
rad	Radian	SSMD	Solid State Modular Design	Veh.	Vehicle
rad/s	Radian Per Second	ST	Surface Treatment or Spiral To Tangent	Vert.	Vertical
RBAC	Rock Base Asphaltic Concrete	St. or ST.	Street	VF	Vertical Foot
RBST	Rock Base Surface Treatment	Sta.	Station	Vh	Verified Horizontal Location
RC	Reverse Crown	Stab.	Stability or Stabilization	VMS	Variable Message Sign
RCP	Reinforced Concrete Pipe	STB	Staked Turbidity Barrier	Vol.	Volume
RCPA	Reinforced Concrete Pipe Arch	Std.	Standard	VP	Vertical Panel
Rd.	Road or Round	Stg.	Strong	VPD or Vpd.	Vehicles Per Day
Rdsd.	Roadside	Stge.	Storage	VPH or Vph.	Vehicles Per Hour
Rdwy.	Roadway	Stl.	Steel	VPHPL or Vphpl.	Vehicles Per Hour Per Lane
Rec.	Recovery	Str.	Structure	VRMS	Volts Root Mean Square
Rect.	Reticuline or Rectangular	Sty.	Story	Vv	Verified Vertical Elevation
Ref.	Reference	SU	Single Unit Trucks	Vvh	Verified Vertical Elevation And Horizontal Location
Refl.	Reflective	Sub. or Subs.	Subsoil	VW	Variable Width
Reg.	Region, Regular, Registered or Regulation	Sub. or Subst.	Substitute	W	Width, Wide, West or Watt
Reinf.	Reinforced or Reinforcing	Subgr.	Subgrade	W/C	Water-Cement Ratio
Rejuv.	Rejuvenation	Suppts.	Supports	WB	Westbound
Reloc.	Relocated	SUR or Sur.	Survey	Wb.	Weber
Rem.	Removal	Surf.	Surface	WB40	Intermediate Semi Trailer
Repl.	Replace	SW	Southwest	WB50	Large Semi Trailer
Req. or Reqd.	Required	SW or Swk.	Sidewalk	WB62	Interstate Semi Trailer
Res.	Residence or Residential	Sys. or Syst.	System	WB67D	Tandem Semi Trailer
RGS	Rigid Galvanized Steel	Sv	Sievert	WM	Water Main
RHW	Insulation (Moisture & Heat Resistant Rubber)	Sym.	Symmetrical	W.P.I.	Work Program Item
RM	Reference Monument	T	Tangent, Length Of Curve, Percent Trucks, Tesla,	WT	Water Table Or Weight
r/min	Revolution Per Minute	T, TWP or Twp.	Township	WWF	Welded Wire Fabric
RP	Reference Point	t	Metric Ton	WWR	Welded Wire Reinforcing
rpm	Revolution Per Minute	tan.	Tangent	X	Coordinate Value (East-West Direction) or Extra
RPM	Raised Reflective Pavement Markers	TBM	Temporary Bench Mark	X Rd.	Cross Road
r/s	Revolution Per Second	TC	Tangent To Curve	Xing.	Crossing
RR	Railroad	TCB	Temporary Concrete Barrier	Xsec.	Cross Section
RSDU	Radar Speed Display Unit	TCE	Temporary Construction Easement	Y	Coordinate Value (North-South Direction)
Rsf.	Resurface	TCP	Terra Cotta Pipe	Yd.	Yard
Rt.	Right	TCZ	Traffic Control Zone	Yr.	Year
RU	Rack Unit	TDLC	Transportation Design For Livable Communities		
R/W, RDW	Right Of Way	Tel.	Telephone		
RX	Receive	Temp.	Temperature or Temporary		
S or s	Speed, South, Siemens, Or Second	Theo.	Theoretical		
SAHM	Sand-Asphalt Hot Mix	THRMP/LSTC	Thermoplastic		
SAN or San.	Sanitary	THW or THWN	Insulation (Flame Retardant, Moisture And Heat Resistant Thermoplastic)		
SB	Southbound	Thick.	Thickness		
SBAC	Shell Base Asphaltic Concrete	Tk	Thick, Thickness or Truck		
SBRM	Sand Bituminous Road Mix	Tn.	Ton		
SBST	Shell Base Surface Treatment	Traf.	Traffic		
SC	Seal Coat or Spiral To Curve	Trans.	Transition, Transverse, Translate or Transportation		
Sch.	Schedule	Treat.	Treatment		
SCST	Sand-Clay Surface Treatment	TS	Tangent To Spiral		
SD	Side Drain, Storm Drain	TSC	Length Of Tangent (Spiral Curve)		
SE	Southeast	TTC	Temporary Traffic Control		
Sec.	Second	TVSS	Transient Voltage Surge Suppression		
Sect.	Section	TX	Transmit		
Sed.	Sediment	Typ.	Typical		
Sep.	Separator	Upass.	Underpass		
Seq.	Sequential	UG	Underground		
Serv.	Service	UL	Underwriters Laboratories		
SF	Adjustment Factor In Percent, Silt Fence	Ult.	Ultimate		
SG	Subgrade	Ultd.	Unlimited		
SG	Specific Gravity	Unddr.	Underdrains		
Sh. or Sht.	Sheet	Undrdwy.	Underroadway		
Shldr.	Shoulder	UNL or Undl.	Unloaded		
SHW	Seasonal High Water	Untr.	Untreated		
SIP	Stay In Place	UPS	Uninterruptible Power Supply		
SP	Superpave	USC & GS	US Coast and Geodetic Survey (now National Geodetic Survey)		
Spa.	Space	USGS	US Geological Survey		
Spcg. or Sp.	Spacing	USPS	United States Postal Service		
Spec.	Specification	Util.	Utilities		
SPT	Standard Penetration Test	UV	Ultraviolet		
Sq. Ft., SF, or S.F.	Square Foot				
Sq. In.	Square Inch				
Sq. Yd., SY or S.Y.	Square Yard				
SR or S.R.	State Road				
SRAP	Spiral Rib Aluminum Pipe				

The abbreviations listed are the standard for contract plans production. This list is not all inclusive. Other Department accepted abbreviations may be used when deemed more appropriate. Where special abbreviations are used a descriptive tabulation may be necessary in the plans.



STANDARD SYMBOLS FOR KEY MAP

 Highway With Full Control of Access  Highway With Frontage Roads  Highway Interchange  Proposed Controlled Access Highway  Divided Highway  Hard Surfaced Road  Soil, Gravel Or Shell Surfaced Road  Graded And Drained Road  Unimproved Road  Primitive Road  Private Road  Streets In Inset Or Delimited Areas  Extension Of Local Roads Within Cities  FAI Federal Aid Interstate Highway  FAU Federal Aid Urban Highway  FAP Federal Aid Primary Highway  FAS Federal Aid Secondary Highway  NFR National Forest Road  SFR State Forest Road  SPR State Park Road  Interstate Highway  US Numbered Highway  State Highway  County Road	 Free Ferry  Toll Ferry  Canal Or Drainage Ditch  Intracoastal Waterway  Narrow Stream  Wide Stream  Dam  Dam Or Spillway With Lock  Dam With Road  Flood Control Structure  Lake, Reservoir Or Pond  Intermittent Pond  Meandered Lake  Marsh Or Swamp  Mangroves  Levee Or Dike  Levee Or Dike With Road  Highway Bridge  Small Bridges Closely Spaced  Drawbridge  Highway Grade Separation  Tunnel  State Boundary Line  County Boundary Line  Civil Township Boundary  Extended Township Line  Land Grant Line  Land Section Line  State Survey Section Line  Survey By Others  Location Of Inset Boundary Within Map  Military Reservation Boundary  College Or University Boundary  Corporate Limits  Delimited Area, Population Est.  Reservation, Forest Or Park Boundary  Wildlife Refuge Boundary	 Residential Area Under Development  Lighthouse  State Capital  County Seat  Other City Or Village  Seminole Indian Village  Welcome Station  Wayside Park Or Small Park  Park With Boat Ramp  Boat Ramp  Museum  Recreational Area Or Historic Site  Scenic Site  Post Office  School  Church  Cemetery  Church And Cemetery  Hospital, Health Center Or Rest Home  Toll House, Port Of Entry Or Weight Station  Fair Grounds, Race Course Or Rodeo Arena  Mine Or Strip Mine  Governmental Research Station	 Agricultural Inspection Station  Farmers Market  Game Preserve  Game Checking Station  Bird Sanctuary  Fire Control Headquarters  Lookout Tower  Fire Station  Patrol Or Police Station  Correctional Institution Or Road Camp  Department of Transportation Facility  Coast Guard Station  Armory  Junkyard  Sanitary Fill  Sewage Disposal Plant  Incinerator  Power Plant  Power Substation  Communications Facility  Locked Gate Or Fence  Triangulation Station
--	--	--	--

GENERAL NOTE

1. Symbols on this Index are intended for use on all Roadway, Signing And Marking, Signalization, and Lighting projects. For work zone traffic control symbols refer to Index 600. When additional or similar symbols are used, legends or notations may be required for clarity.



2010 FDOT Design Standards

STANDARD SYMBOLS

Last Revision 07/01/05	Sheet No. 1 of 3
Index No. 002	

STANDARD SYMBOLS FOR PLAN SHEETS

GENERAL SYMBOLS

	State Line
	County Line
	Township Line
	Section Line
	City Line
	Base Or Survey Line
	Right-Of-Way
	Easement Line
	Limited Access Line
	Fence Line
	National Or State Park Or Forest
	Grant Line
	Railroad (Drainage Maps)
	Railroad (Detail Plans)
	Fence (Limited Access)
	Box Culvert
	Bridge
	Pipe Culvert-Mitered End Section
	Pipe Culvert-Straight Endwall
	Pipe Culvert-U-Type Endwall
	Pipe Culvert-Median Drain
	Pipe Culvert-Other End Treatments
	18" SD Storm Drain (Proposed)
	18" SD Storm Drain (Existing)
	Inlet
	Manhole
	Tied Longitudinal Joint
	Keyed Longitudinal Joint
	Doweled Transverse Expansion Joint
	Doweled Transverse Contraction Joint
	Transverse Contraction Joint Without Dowels
	Survey Reference Point
	ALACHUA Triangulation Station
	B.M. NO. 112 Bench Mark
	Point Of Intersection
	North Arrow
	Edges Of Existing Pavement And Sidewalk
	Guardrail
	c.c. Crash Cushion (Attenuator)
	Piling Pier Column
	Concrete Monument
	Base Line
	Centerline
	Flow Line
	Property Line
	Delta Angle
	Approximate
	Round Or Diameter

	Curb
	Curb And Gutter
	Water Well, Spring
	Levee
	MP 327 Railroad Mile Post
	Railroad Signal With Gate
	Railroad Switch
	Gate
	Pump Island
	Storage Tank (Surface)
	Storage Tank (Underground)
	Mine Or Quarry
	Borrow Pit
	Church
	Store
	RES Residence
	B Barn
	S School
	Synthetic Bales
	Silt Fence
	Floating Turbidity Barrier
	Staked Turbidity Barrier
	Stream
	Shore Line
	Marsh
	Wetland Boundary (Proposed)
	Wetland Boundary (Existing)
	Hedge
	Trees
	Edge Of Wooded Area
	Shrubbery
	Grove Or Orchard
	Definition Of Skew For Cross Drains And Barrels Of Concrete Box Culverts
	Rt. Skew Lt.
	Concrete
	Wood
	e Rate Of Superelevation

UTILITY ADJUSTMENT SYMBOLS

EXISTING	PROPOSED	EXISTING	PROPOSED
		W - - - - 6" - - - - W	W W W W W 6" M M M M M M M M Water Main
		NPW - - - 6" - - - M d N	NPW NPW 6" M d N M d N Non Potable Water
		S - - - - 8" - - - - S	S S S S S 8" S S S S S Sanitary Sewer
		G - - - - 6" - - - - G	G G G G G 6" G G G G G Gas
		RD - - - - 4" - - - - RD	RD RD RD 4" RD RD RD Roof Drain
		PET - - - 8" - - - L B D	PET PET 8" PET PET Petroleum
		STM - - - 12" - - - W L S	STM STM 12" W L S W L S Steam
		CAS - - - 12" - - - S V D	CAS CAS 12" S V D S V D Casing
		DT - - - 4"x4" - - - L O	DT DT 4"x4" L O L O Duct
		BE - - (7.5 kV) - - 3 B	BE BE (7.5 kV) BE BE Buried Electric
		OE - - (7.5 kV) - - 3 O	3 O 3 O (7.5 kV) OE OE Overhead Electric
		BTV - - - 3" - - - A L B	BTV BTV 3" BTV BTV Buried Cable Television
		OTV - - - 2" - - - A L O	A L O A L O 2" A L O A L O Overhead Cable Television
		BT - - - 2" - - - L B	BT BT BT 2" L B L B L B Buried Telephone
		OT - - - 2" - - - L O	OT OT OT 2" L O L O L O Overhead Telephone
		BFO - - - 2" - - - O J B	BFO BFO 2" O J B O J B Buried Fiber Optic
		OFO - - - 1" - - - O J O	OFO OFO 1" OFO OFO Overhead Fiber Optic

See General Note, Sheet 1 of 3



STANDARD SYMBOLS FOR PLAN SHEETS

TRAFFIC SIGNALS SYMBOLS

EXISTING	PROPOSED	
		Traffic Signal Head (Span Wire Mounted)
		Traffic Signal Head (Pedestal Mounted)
		Traffic Signal Head (Mast Arm Mounted)
		Traffic Signal Pole (Concrete, Wood, Metal)
		Vehicle Detector (Loop)
		Signal Cable (On Messenger Wire)
		Conduit
		Vehicle Detector (Points)
		Pedestrian Detector
		Pedestrian Signal Head (Pole Or Pedestal Mounted)
		Controller Cabinet (Base Mounted)
		Controller Cabinet (Pole Mounted)
		Walk - Dont Walk
		Flashing Dont Walk
		Signal Face Number
		Signal Lens
		Programmed Signal Head
		Messenger Wire
		Pole Tabulation Cross Reference
		Pole Tabulation Cross Reference (Joint Use Pole)
		Signal Phase

LIGHTING SYMBOLS

EXISTING	PROPOSED	
		Pole & Luminaire
		Existing Pole & Luminaire To Be Removed
		Final Position Of Relocated Or Adjusted Pole & Luminaire
		High Mast Lighting Tower
		City Or Utility Owned Luminaire & Pole
		PVC (Polyvinyl Chloride) Lighting Conduit And Conductors
		Rigid Galvanized Lighting Conduit And Conductors
		Lighting Pull-Box
		Light Distribution Point
		Joint Use Pole
		Pier Cap Underdeck Luminaire
		Pendant Hung Underdeck Luminaire

SIGNING AND PAVEMENT MARKING SYMBOLS

	Pavement Arrow
	Single Solid Line
	Double Solid Line
	Skip Line
	Stop Bar
	Traffic Sign (Post Mounted)
	Traffic Sign (Overhead)
	Sign Number
	Sign Item Number
	Traffic Flow Arrow

See General Note, Sheet 1 of 3

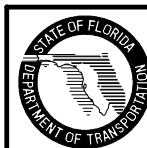

2010 FDOT Design Standards

STANDARD SYMBOLS

Last Revision 07/01/05	Sheet No. 3 of 3
Index No. 002	

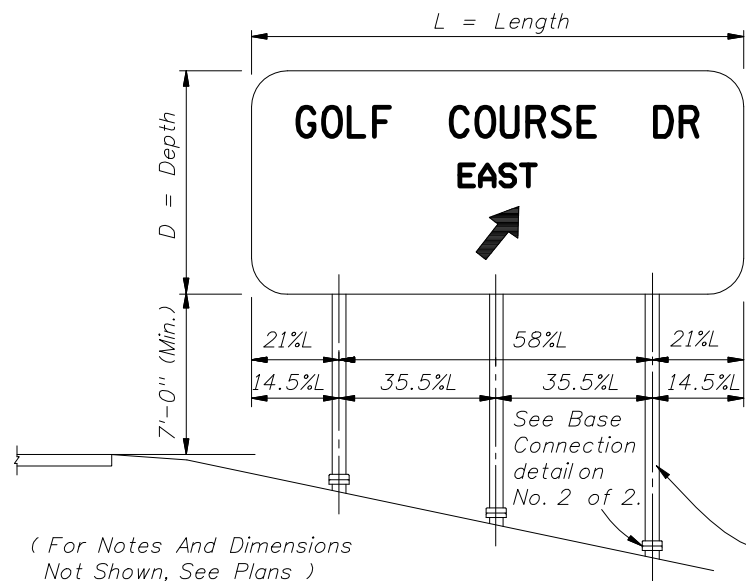

TYPICAL ELEVATION

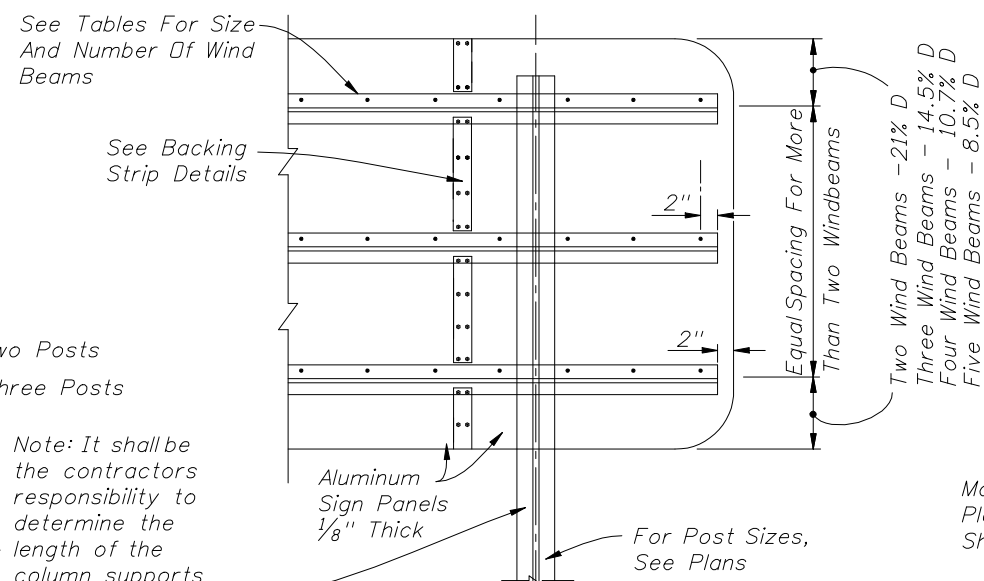

PARTIAL REAR ELEVATION

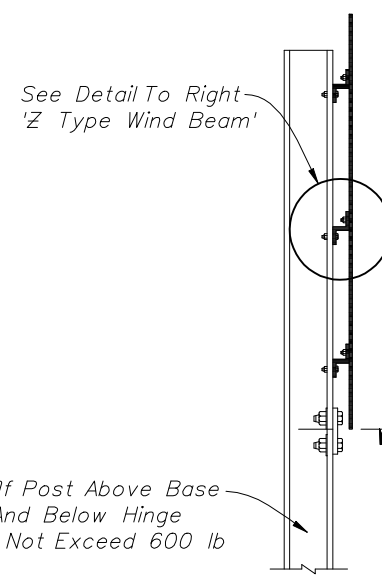

SIDE VIEW

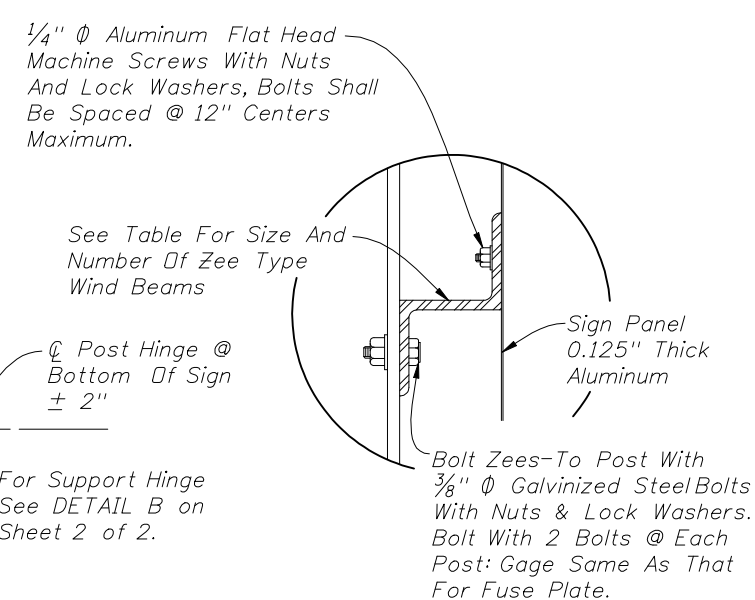

Z TYPE WIND BEAM

(For Notes And Dimensions Not Shown, See Plans)

Note: It shall be the contractor's responsibility to determine the length of the column supports in the field prior to fabrication.

Mass Of Post Above Base Plate And Below Hinge Should Not Exceed 600 lb

For Support Hinge See DETAIL B on Sheet 2 of 2.

GENERAL NOTES

Note: If the sign panels are deeper than 10', a Horizontal Panel Splice is allowed at an interior Z bar support, shop drawings shall be required. Minimum panel section width = 2'-6".

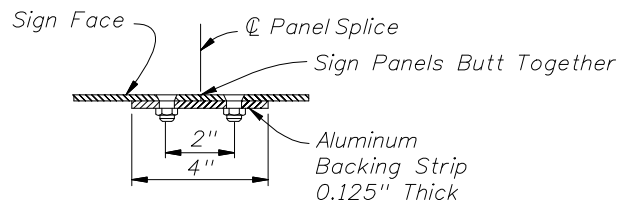

BACKING STRIP DETAILS

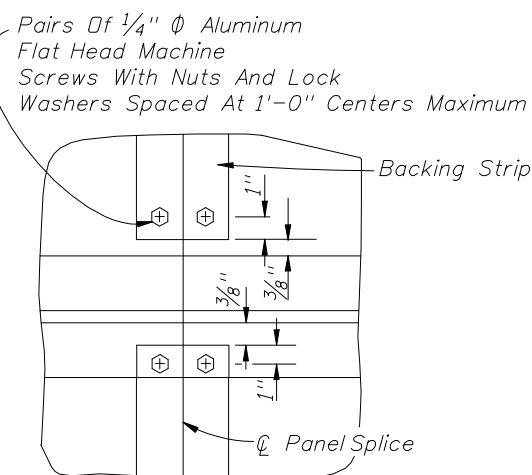

DESIGN SPECIFICATIONS: Design according to FDOT Structures Manual (current edition). Standard Specification for Structural Supports for Highway Signs, Luminaries and Traffic Signals, AASHTO 2001.
 WELDING: For welding refer to the latest editions of the AWS Structural Welding Codes for Steel and Aluminum, the AASHTO Standard Specifications for Welding Structural Steel Highway Bridges.
 ALUMINUM MATERIALS: All aluminum materials shall meet the requirements of the Aluminum Association's Alloy 6061-T6 and also the following ASTM specifications: Sheets and plates, B209; extruded tube, bars, rods & shapes, B221; and standard structural shapes, B308. No stenciling permitted on sheets. Aluminum welding rods shall meet the requirements of Aluminum Association Alloy No. 5556 filler wire.
 ALTERNATE MATERIAL: Material meeting the requirements of ASTM B209 or Aluminum Association Alloys 5154-H38 or 5052-H38 may be used for sheet and plate. Material meeting the requirements of Aluminum Association Alloy 6351-T5 and ASTM B221 may be used for extruded bars, rods, shapes and tubes.
 STRUCTURAL STEEL: All structural steel shall meet the requirements of ASTM A36.
 ALUMINUM BOLTS, NUTS, & LOCK WASHERS: Aluminum bolts shall meet the requirements of Aluminum Association Alloy 2024-T4 (ASTM F468). The bolts shall have an anodic coating at least 0.0002" thick and be Chromate sealed. Lock washers shall meet the requirements of Aluminum Association Alloy 7075-T6 (ASTM B221). Nuts shall meet the requirements of Aluminum Association Alloy 6061-T6 or 6262-T9 (ASTM F467).
 STEEL BOLTS, NUTS, & WASHERS: All steel bolts, nuts and washers shall meet the requirements of ASTM A325.
 TOLERANCES: All above materials shall be in accordance with the governing ASTM specifications.
 GALVANIZED: All steel shapes, angles, tees, plates, bolts, nuts and washers shall be galvanized in accordance with Standard Specifications 962-9.
 BASE CONNECTION: High strength bolts L₂ in the base connection shall be tightened only to the torque shown in the table on sheet 2 of 2. Overtightened base connections will not be accepted.
 FUSE PLATE: All holes in fuse plates shall be drilled. All plate cuts shall, preferably, be saw cuts; however, flame cutting will be permitted provided all edges are round. Metal projecting beyond the plane of the plate face will not be allowed.
 SIGN FACE: All sign face corners shall be rounded.
 SHOP DRAWINGS: When ground sign supports are fabricated in accordance with these plans no shop drawings are required. Shop drawings will be required for approval when the column length exceeds the length shown in the plans by more than 2'-0". However, shop drawings for sign panels, messages, lettering and quantities shall be submitted to the Engineer of Record for approval.
 FABRICATOR NOTE: All bolts, except L₂ bolts and zee to post bolts, shall be tightened in accordance with Section 700 of the Specifications.
 FOUNDATION: Contractor may use precast foundations in pre-drilled holes a minimum of 12" larger than the foundation indicated on the plans in either wet or dry conditions. The holes shall be clean and without loose material. Temporary casing shall be required if the soil is unstable. Fill the void around the precast foundation with flowable fill meeting the requirements of Section 121 or clean sand placed using hydraulic methods. The cost of flowable fill, installing and removal of casing shall be included in the unit price of Sign Multi-Post.

DESIGN WIND SPEEDS BY COUNTY

- 110 mph Alachua, Baker, Bradford, Clay, Columbia, Gadsden, Gilchrist, Hamilton, Hardee, Jackson, Jefferson, Lafayette, Lake, Leon, Madison, Marion, Polk, Putnam, Sumter, Suwannee, and Union Counties.
- 130 mph Bay, Brevard, Calhoun, Charlotte, Citrus, DeSoto, Dixie, Duval, Flagler, Franklin, Glades, Gulf, Hendry, Hernando, Highlands, Hillsborough, Holmes, Lee, Levy, Liberty, Manatee, Nassau, Okaloosa, Okeechobee, Orange, Osceola, Pasco, Pinellas, Sarasota, Seminole, St. Johns, Taylor, Volusia, Wakulla, Walton, and Washington Counties.
- 150 mph Broward, Collier, Escambia, Indian River, Martin, Miami-Dade, Monroe, Palm Beach, Santa Rosa, and St. Lucie Counties.

Wind	No. Beams	Max. Depth	Wind	No. Beams	Max. Depth
110	2	7'-0"	150	2	6'-0"
110	3	12'-0"	150	3	10'-4"
110	4	16'-4"	150	4	14'-0"
110	5	20'-8"	150	5	17'-8"
130	2	6'-8"			
130	3	11'-4"			
130	4	15'-4"			
130	5	19'-0"			

SIZE OF WIND BEAMS		
Size Of Zee*	Length Of Sign (Feet)	
	2 Posts	3 Posts
Z 1.75 x 1.75 x 1.08	0 - 11'-0"	0 - 17'-4"
Z 3 x 2.69 x 2.33	11'-1"-19'-0"	17'-5"-29'-6"
Z 3 x 2.69 x 3.38	19'-1"-20'-8"	29'-7"-31'-6"

*Note: Zees Are Aluminum - No Steel Equivalent Available Designation Gives (Member Depth) x (Flange=Width) x (lb/ft)



2010 FDOT Design Standards

MULTI-COLUMN GROUND SIGN

Last Revision	Sheet No.
07/01/09	1 of 2
Index No.	
11200	

H. S. Bolt With Hex Head, Hex Nut & 3 Washers With Each Bolt. See Table For Bolt Diameter And Torque. See Bolting Procedure.

Remove All Galvanizing Runs Or Beads In Washer Area
See Bolt Keeper Plate Detail

Top of Foundation See Detail Below

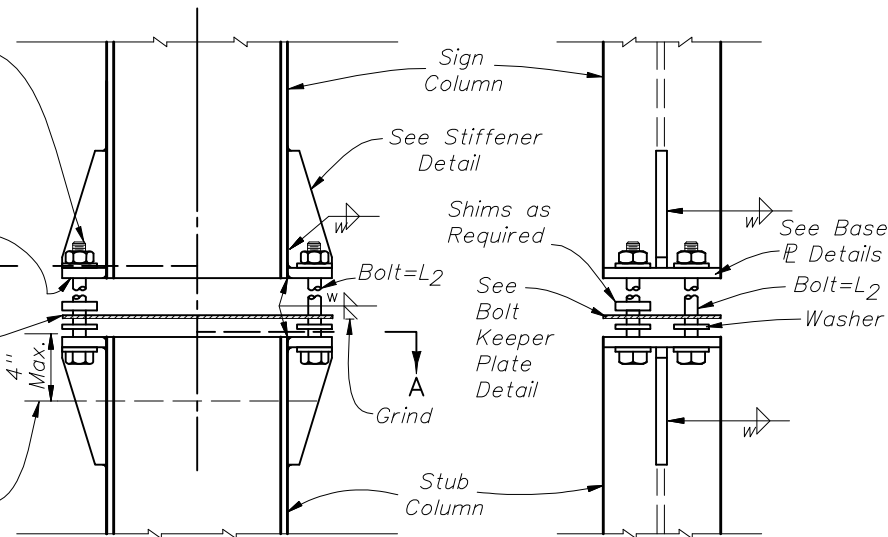

SIGN COLUMN & STUB COLUMN ELEVATION
BASE CONNECTION

Flange Holes For Fuse And Hinge Plate Shall Be Drilled Or Sub-Punched and Reamed. H.S. Bolts (See Table For Size), For Bolt Tension See the Specification. Flat Washers (Typ.)

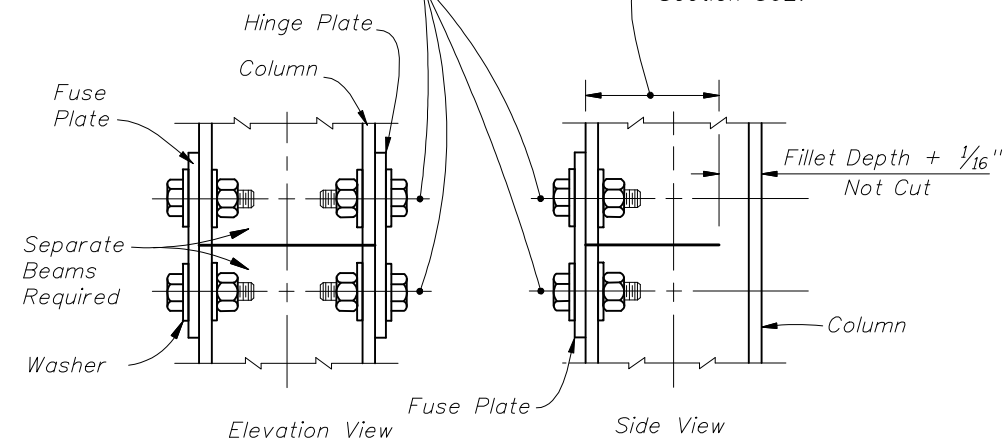

OPTIONAL HINGE TYPICAL HINGE

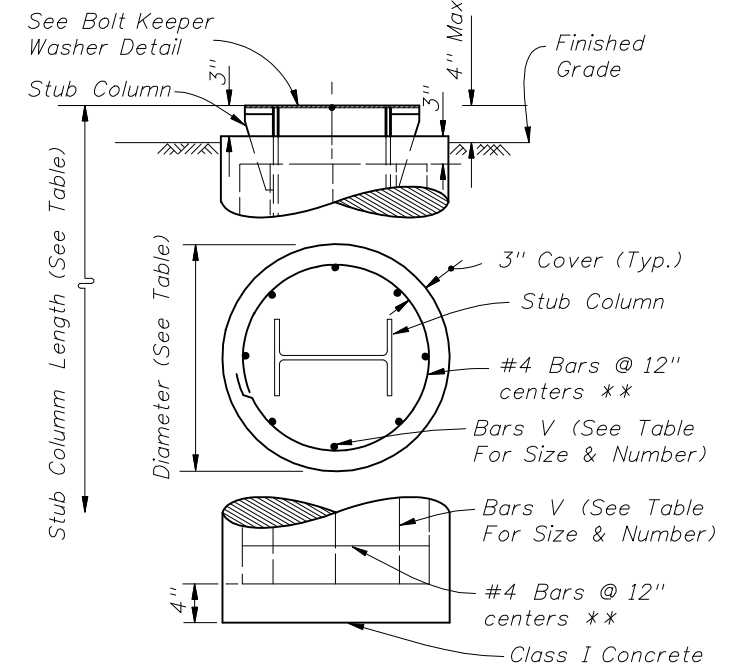

FOUNDATION ELEVATION

NOTE: All Reinforcing To Be Grade 60.

** At the Option of the Contractor, D10 Spiral Wire @ 6" Pitch, Three Flat Turns Top and One Flat Turn Bottom may be Utilized in Lieu of Specified.

Shop-weld assemblies of foundation stirrup reinforcing bars are permitted in reinforced concrete foundation provided that:

1. The reinforcing bars conform to ASTM Specification A706/706M.
2. The holding wires conform to ASTM Specification A82 or A496.
3. The Shop welding is performed by machines under a continuous, controlled process, approved by the Engineer.
4. Quality control test are performed on shop-welded specimens and the test results are available, upon request, to the Engineer.

FUSE & HINGE PLATES

(See Fabricator Note on Sheet 1 of 2)

DETAIL B

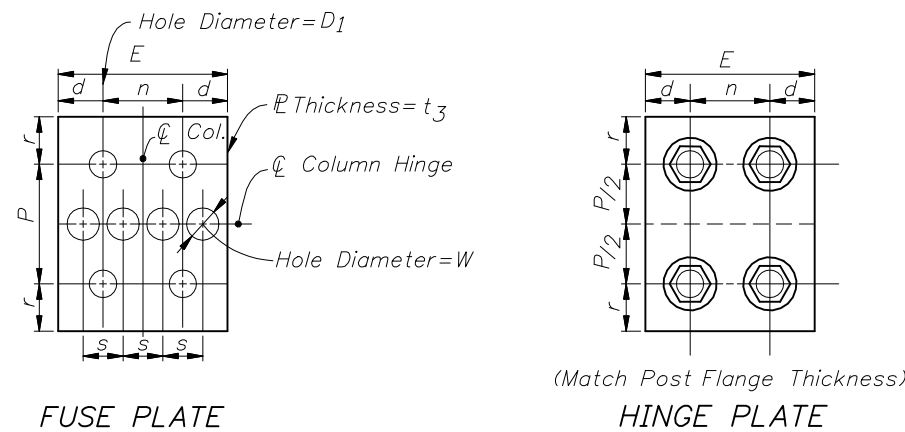

FUSE PLATE

HINGE PLATE

(Match Post Flange Thickness)

Direction of Traffic

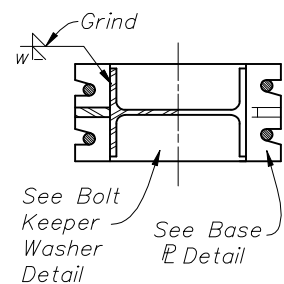

SECTION A-A

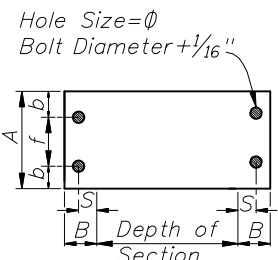

BOLT KEEPER PLATE

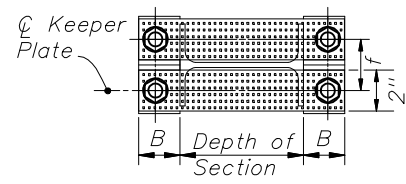

ALTERNATE BOLT KEEPER PLATE

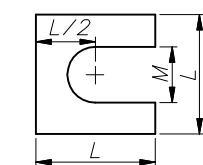

Provide 2 - 0.0149" Thick and 2 - 0.0329" Thick Brass Shims (ASTM B36) Per Post

SHIM DETAIL

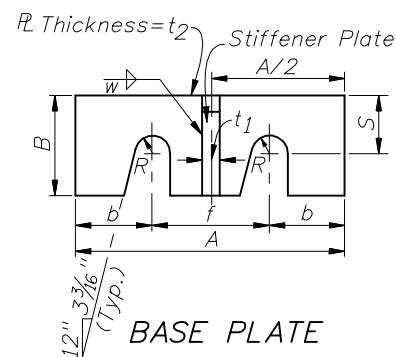

BASE PLATE

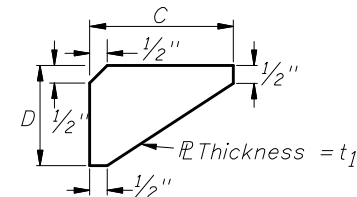

STIFFENER PLATE

PROCEDURE FOR ASSEMBLY OF BASE CONNECTION

1. Assemble post to stub with bolts and with one flat washer on each bolt between plates.
2. Shim as required to plumb post (see shim detail).
3. Tighten all L2 bolts the maximum possible with 1'-0" to 1'-3" wrench to bed washers and shims and to clean bolt threads. Then loosen each bolt in turn and retighten in a systematic order to the torque specified in the table.
4. Burr threads at junction with nut using a center punch to prevent nut loosening.
5. Sections shown are for installation on right shoulder. For left shoulder plate slot bevels are opposite hand from that shown.

Section *	BASE CONNECTION DATA											SHIM		FUSE (HINGE) PLATE DATA											FOUNDATION DATA			
	A	B	C	D	Bolt Size(L2) & Torque(in-lb)	R	b	f	S	t ₁	t ₂	w	L	M	Bolt Size	E	P	D ₁	d	n	r	s	t ₃	W	Dia.	Depth	Stub Length	Reinf. Bars V
W 6x12	4 3/4"	2"	5 1/8"	2"	5/8" Ø 345	3/8"	1 1/8"	2 1/2"	1 3/16"	1/2"	1/2"	1/4"	1 3/8"	1 1/16"	5/8"	4 1/4"	3"	1 1/16"	1 1/8"	2"	1 3/16"	1"	1/4"	1 3/16"	2'-0"	5'-6"	2'-4"	10-#6
W 8x18	5 3/4"	2 3/16"	6 1/4"	2 3/16"	3/4" Ø 550	7/16"	1 1/2"	2 3/4"	1 3/8"	1/2"	5/8"	1/4"	1 3/4"	1 3/16"	7/8"	5 1/2"	3 3/4"	1 5/16"	1 1/2"	2 1/2"	1 3/8"	1 5/16"	3/8"	1 1/16"	2'-0"	7'-6"	2'-10"	10-#6
W 10x22	6 1/8"	2 3/8"	8"	2 3/8"	7/8" Ø 640	1/2"	1 1/16"	3"	1 3/8"	1/2"	3/4"	5/16"	2"	1 5/16"	1"	6 3/8"	4 5/16"	1 1/16"	1 3/4"	2 7/8"	1 3/4"	1 1/2"	3/8"	1 3/16"	2'-4"	8'-6"	3'-4"	8-#8
W 10x33	8"	2 3/4"	8"	2 3/4"	1 1/8" Ø 780	5/8"	2"	4"	1 9/16"	1/2"	3/4"	5/16"	2 3/8"	1 3/16"	1 1/8"	7 7/8"	5 5/16"	1 3/16"	2 1/4"	3 3/8"	2"	1 1/8"	1/2"	1 9/16"	2'-4"	10'-3"	4'-0"	8-#8
W 12x40	8"	3"	8"	3"	1 1/8" Ø 780	5/8"	2"	4"	1 1/16"	1/2"	3/4"	5/16"	2 3/8"	1 3/16"	1 1/4"	8 3/8"	5 3/4"	1 5/16"	2 1/4"	3 7/8"	2 3/16"	2"	1/2"	1 11/16"	2'-8"	11'-3"	4'-8"	10-#8

* Designations: Normal Depth in inches and weight in pounds per linear foot.

STEEL POST, BASE, FOUNDATION & FUSE PLATE DETAILS

2010 FDOT Design Standards

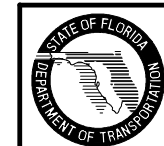

MULTI-COLUMN GROUND SIGN

Last Revision 07/01/09 Sheet No. 2 of 2

Index No. 11200

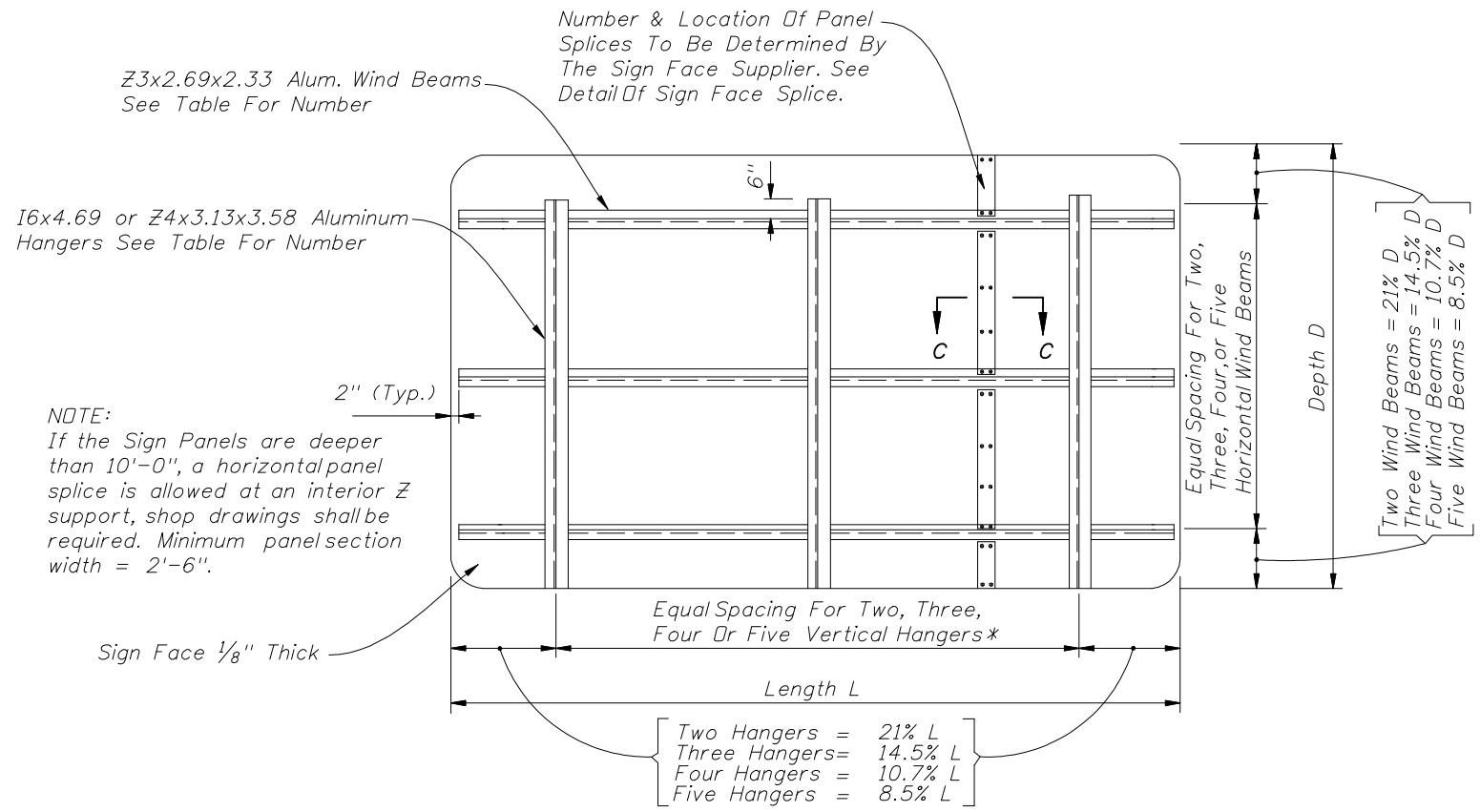

Wind M.P.H.	No. Beams	Max. Depth	Number Of 16x4.69 or Z4x3.13x3.58 Vertical Hanger Beams For Sign Length			
			2 Hangers Sign Length	3 Hangers Sign Length	4 Hangers Sign Length	5 Hangers Sign Length
150	2	5'-0"	0 to 15'-0"	15'-1" to 30'-0"	30'-1" to 45'-0"	
150	3	8'-6"	0 to 15'-0"	15'-1" to 30'-0"	30'-1" to 45'-0"	
150	4	11'-6"	0 to 13'-0"	13'-1" to 18'-3"	18'-4" to 24'-9"	24'-10" to 31'-4"
150	5	14'-0"	0 to 13'-0"	13'-1" to 18'-3"	18'-4" to 24'-9"	24'-10" to 31'-4"
130	2	5'-3"	0 to 15'-0"	15'-1" to 30'-0"	30'-1" to 45'-0"	
130	3	8'-10"	0 to 15'-0"	15'-1" to 22'-3"	22'-4" to 30'-0"	30'-1" to 45'-0"
130	4	12'-0"	0 to 15'-0"	15'-1" to 22'-3"	22'-4" to 30'-0"	30'-1" to 38'-0"
130	5	15'-0"	0 to 11'-7"	11'-8" to 16'-4"	16'-5" to 22'-2"	22'-3" to 28'-0"
110	2	5'-6"	0 to 15'-0"	15'-1" to 30'-0"	30'-1" to 45'-0"	
110	3	9'-6"	0 to 15'-0"	15'-1" to 27'-3"	27'-4" to 37'-0"	37'-1" to 45'-0"
110	4	12'-9"	0 to 15'-0"	15'-1" to 27'-3"	27'-4" to 37'-0"	37'-1" to 45'-0"
110	5	16'-0"	0 to 14'-3"	14'-4" to 20'-0"	20'-1" to 27'-0"	27'-1" to 34'-3"

*Note: Spacing of vertical hangers may be varied slightly or as necessary to clear the truss struts and diagonals at panel points.

TYPICAL SIGN FACE ELEVATION FOR OVERHEAD TRUSS

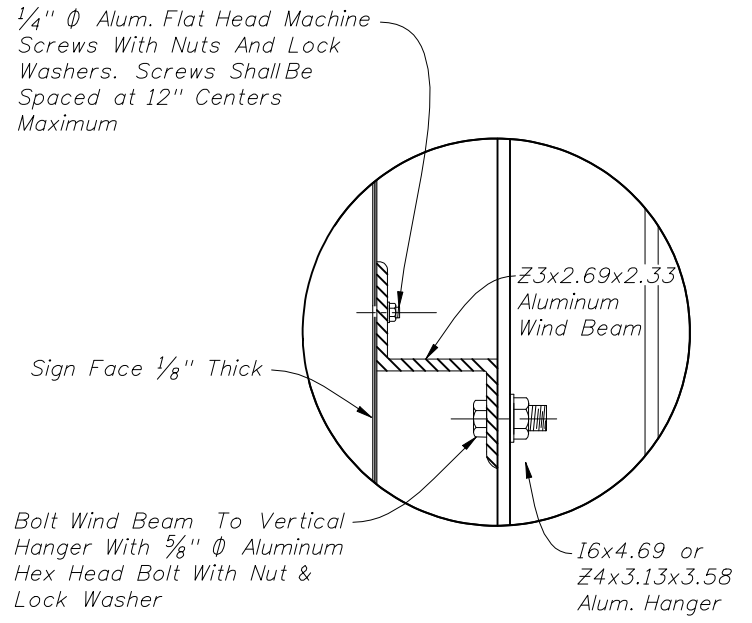
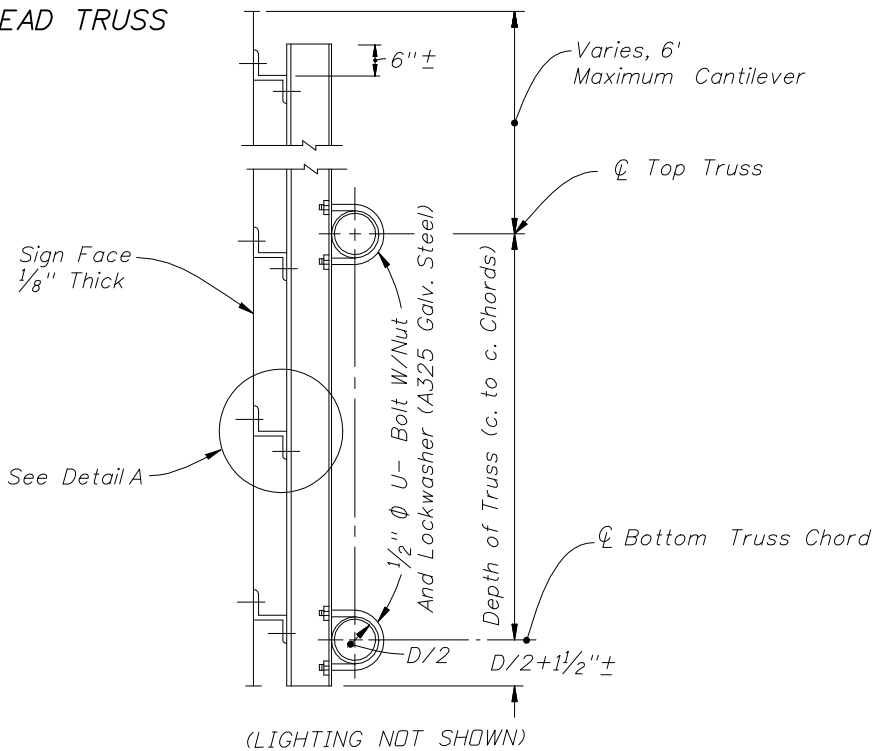
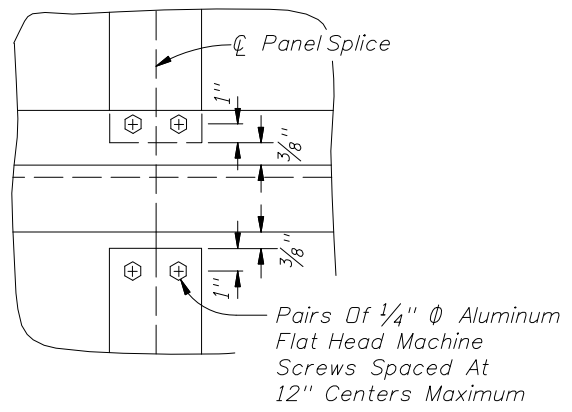
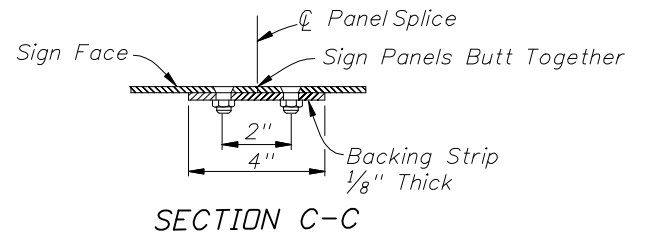

(SHOWING ATTACHMENT OF SIGN FACE PANEL TO VERTICAL HANGER SUPPORTS, VERTICAL I SHAPE HANGER AS SHOWN, Z SHAPE OPTIONAL)

- GENERAL NOTES
- (1) For "General Notes" covering Material Specifications see Index 11200.
 - (2) Design based on 32 ft. maximum height to centroid of sign panel.
 - (3) The Design Wind Speed shall conform to Wind Speed by County shown on Index 11200, Sheet 1 of 2.

DETAILS OF SIGN FACE & TRUSS CONNECTION

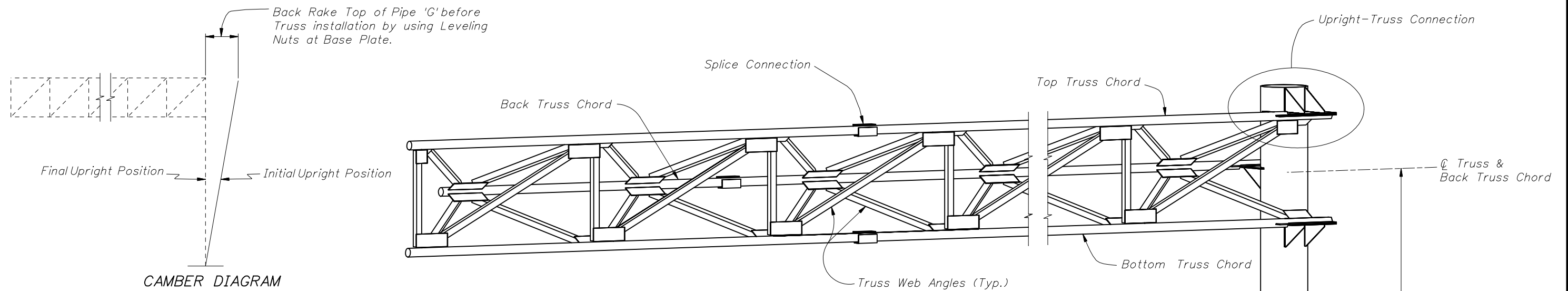

CANTILEVER SIGN STRUCTURE NOTES

- 1) Design according to FDOT Structures Manual. Alternate Designs are not allowed.
- 2) Submit shop drawings for all work. Include:
 - a. Field verification of all upright heights.
 - b. Foundation elevations necessary to insure minimum vertical clearances as per traffic plans.
 - c. Anchor bolt orientation with respect to centerline of truss and the direction of traffic.
 - d. Show chord splices a minimum distance of 2 truss panel lengths apart. "SD" Panel from upright is the closest panel in which a chord splice may be used. See plans for Cantilever Sign Structure Data Table. Upright splices are not allowed.
- 3) Shop Fabrication, Assembly, Handling and Shipping:
 - a. Do not begin fabrication before receiving shop drawing approval.
 - b. Welding: Conform to American Welding Society Structural Welding Code (Steel) ANSI/AWS D1.1 (current edition).
 - c. Shop assemble the entire structure after galvanizing and prior to shipment.
 - d. If necessary, disassemble and secure components for shipment.
- 4) Sign Structure Materials:
 - a. Upright and Chords (Steel Pipe): API -5L-X42 (42 ksi yield) or ASTM A500, Grade B.
 - b. Steel Angles: ASTM A 709, Grade 36.
 - c. Steel Plates: ASTM A 709, Grade 36.
 - d. Weld Metal: E70XX.
 - e. Bolts: ASTM A325 Type 1, (install per Specification Section 700) with single, self-locking nuts.
 - f. Anchor Bolts: ASTM F1554, Grade 55 with ASTM A563 Grade A heavy-hex double nuts.
 - g. Install all nuts per manufacturer's instructions.
 - h. Bolt hole diameters: equal to the bolt diameter plus $\frac{1}{16}$ ".
 - i. Anchor bolt hole diameters: equal to the bolt diameter plus $\frac{1}{2}$ ".
- 5) Galvanization: Nuts, bolts and washers: ASTM F2329. Other steel items: ASTM A123
- 6) Sign Panels: Aluminum. See Elevation drawing for sizes and locations.
- 7) Foundation Materials:
 - a. Reinforcing Steel: ASTM A615, Grade 60.
 - b. Concrete: Class IV, minimum 5.5 ksi compressive strength at 28-days for all environmental classifications for Spread Footing.
Class IV (Drilled Shaft), minimum 4.0 ksi compressive strength at 28-days for all environmental classifications for Drilled Shaft.
- 8) Construct the Sign Structure foundation in accordance with FDOT Specification Section 455.
- 9) Prior to erection, record the as-built anchor locations and provide to the Engineer.
- 10) After placement of the upright and prior to installation of the truss, adjust the leveling nuts beneath the base plate to achieve the back rake shown on the Camber Diagram.
- 11) Place backfill above the footing prior to installation of the sign panels. Do not remove or reduce in height without prior approval of the Engineer.
- 12) Install sign panels as shown on the Elevation drawing.
- 13) Payment: All costs associated with the Sign Structure, Sign Panels, Foundation and all incidental items will be paid for under the Sign Structure pay item.
- 14) Verify CSL access tubes will not interfere with anchor bolt installation before excavating the shaft. When CSL access tube locations conflict with anchor bolt locations, move the CSL access tube location \pm two inches along the inner circumference of the reinforcing cage. Notify the Engineer before excavating the shaft if the CSL access tube locations cannot be moved out of conflict with anchor bolt locations.

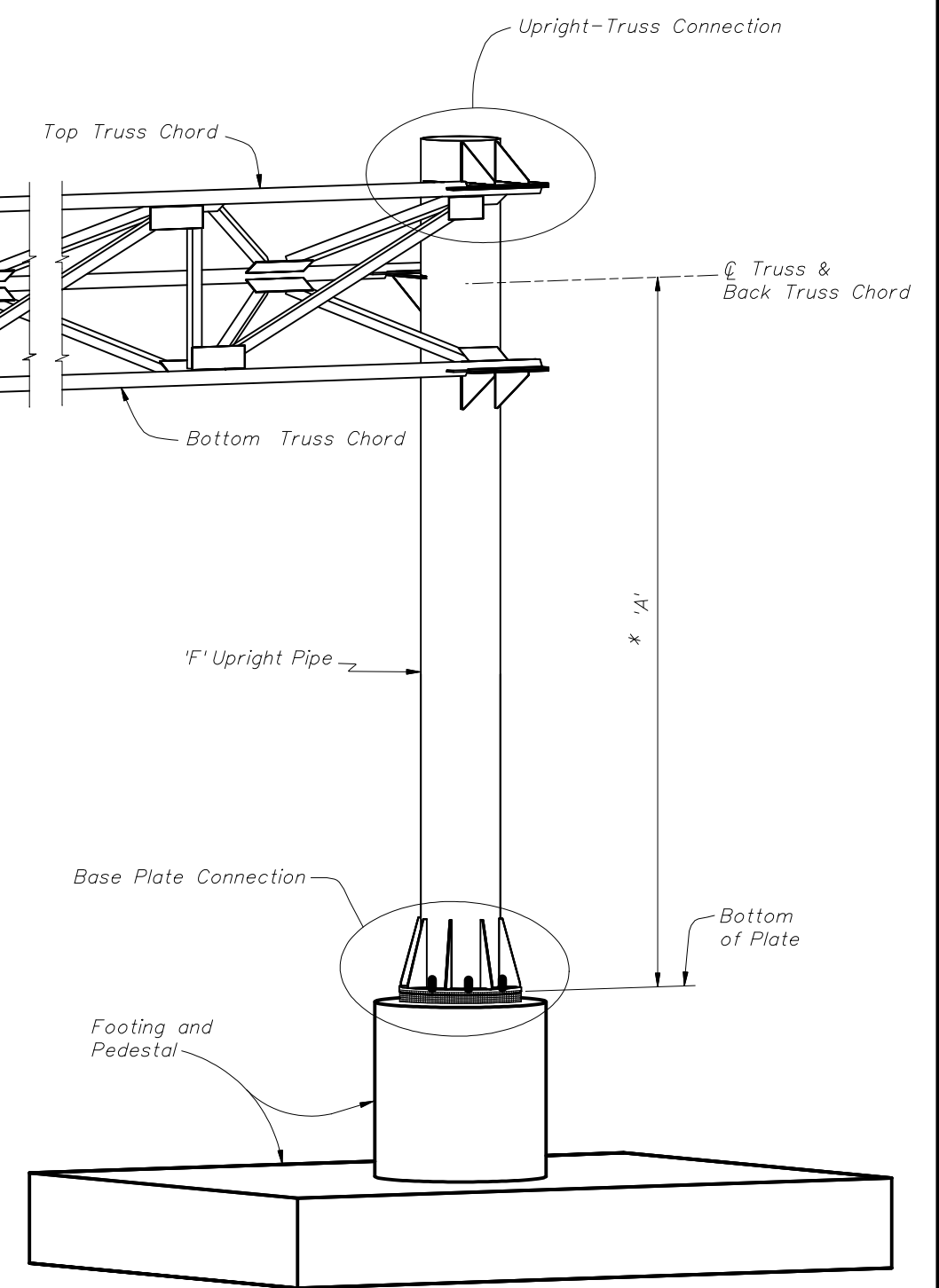

ISOMETRIC VIEW

*NOTE: Contractor shall verify these Dimensions prior to Fabrication of Upright.

NOTE: See Plans for Cantilever Sign Structure Data Table.



2010 FDOT Design Standards

CANTILEVER SIGN STRUCTURE

Last Revision

01/01/09

Sheet No.

1 of 5

Index No.

11310

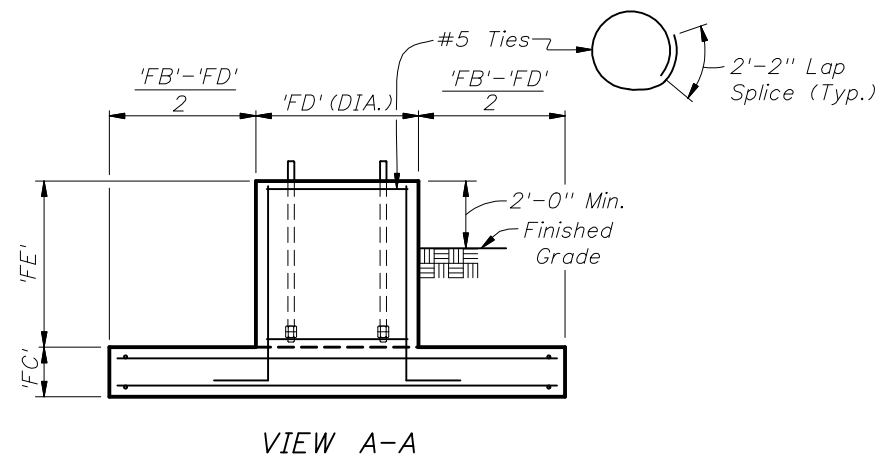
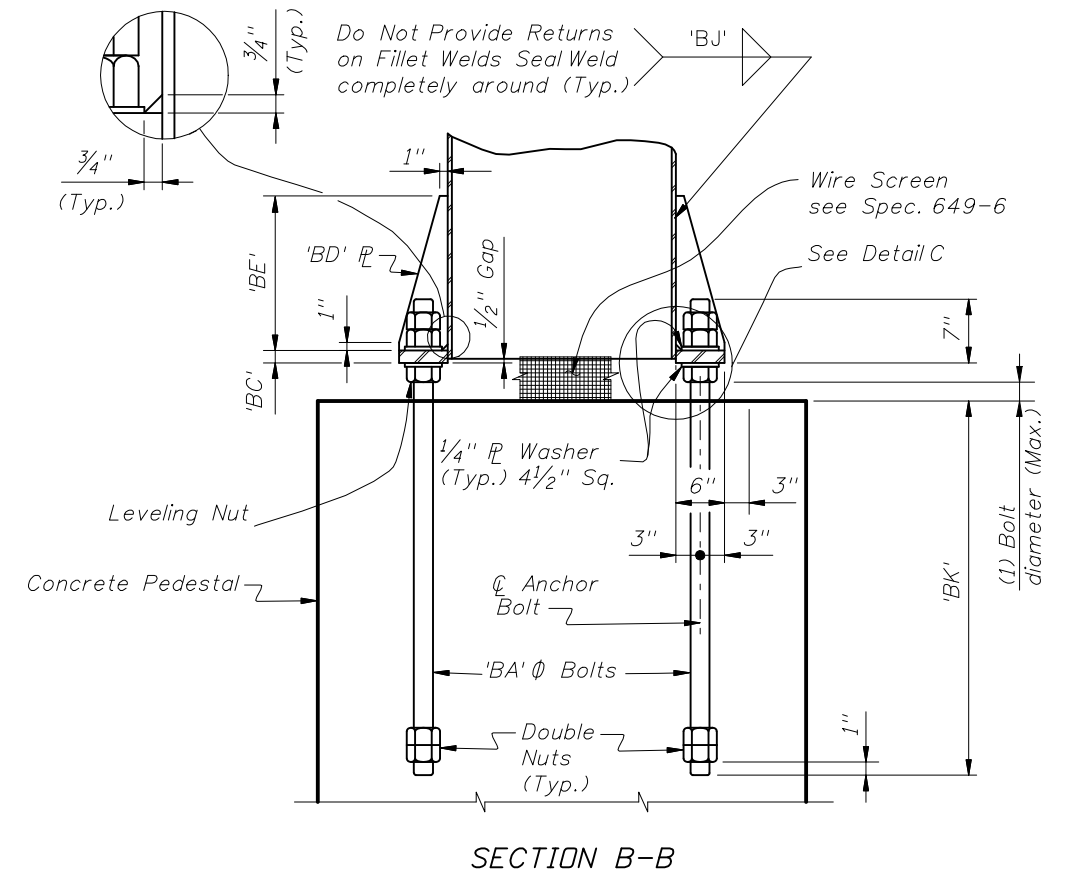
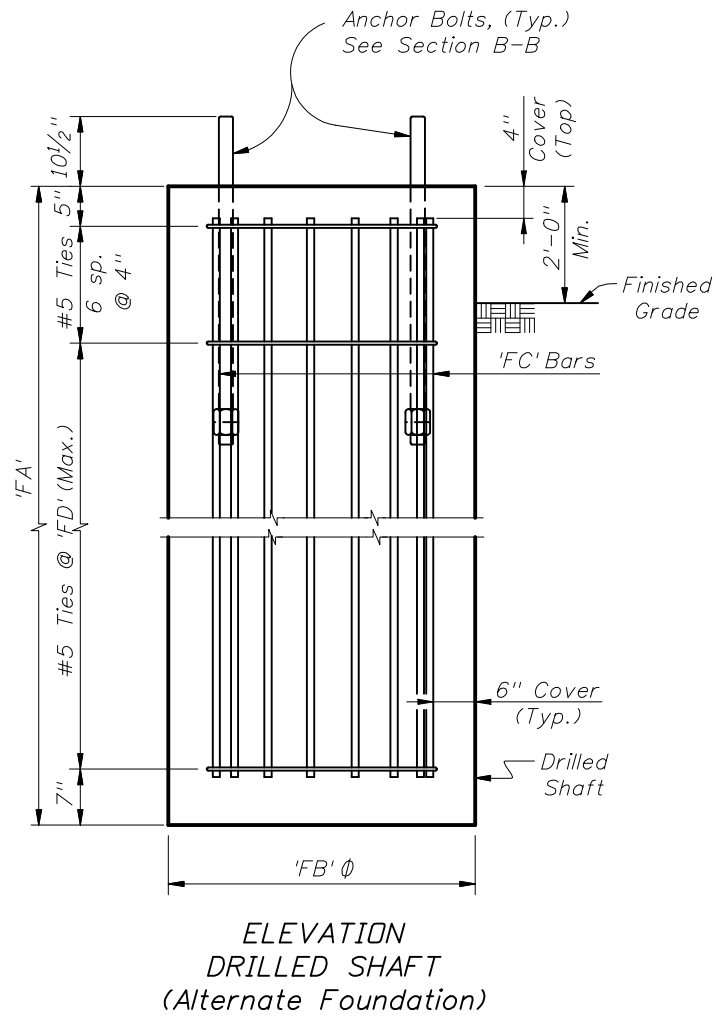
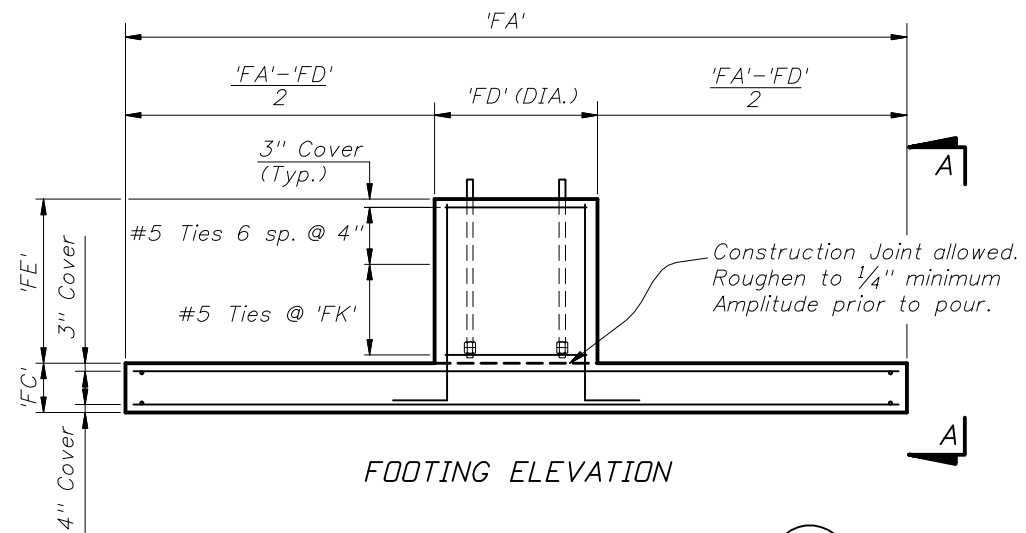
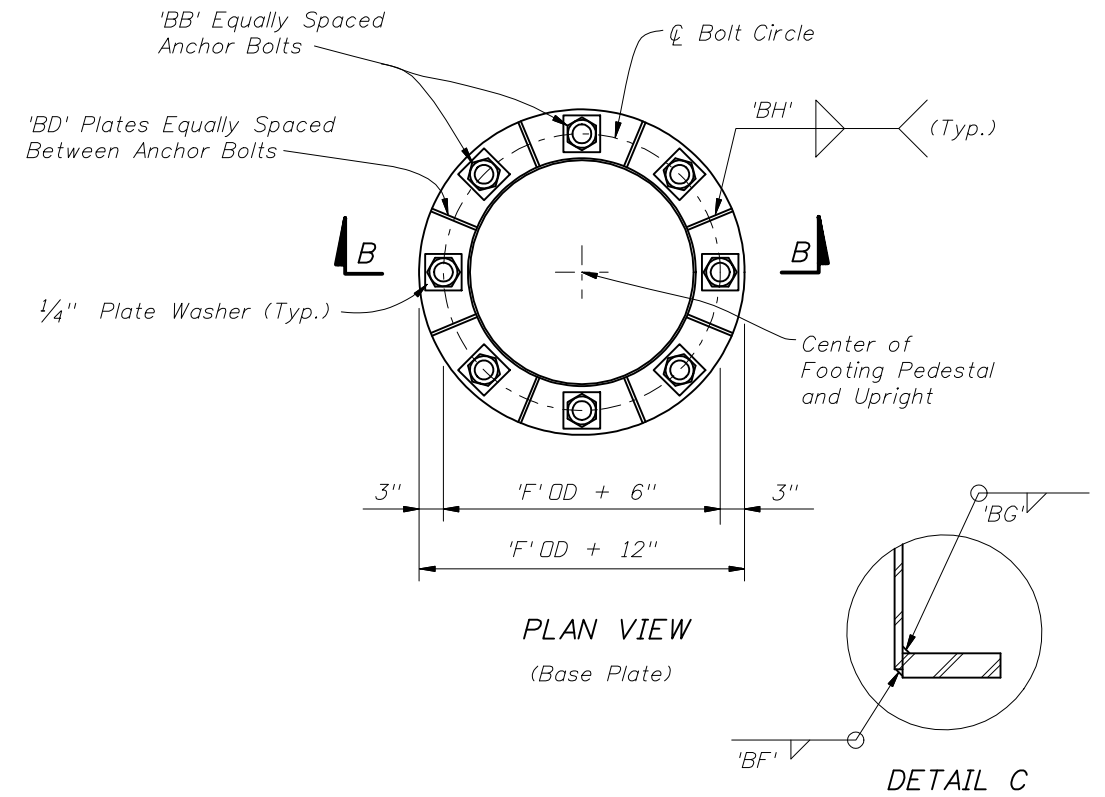
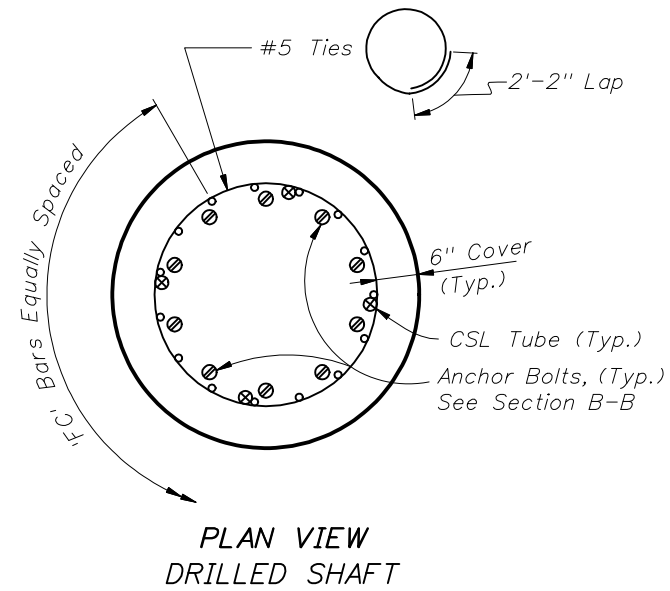
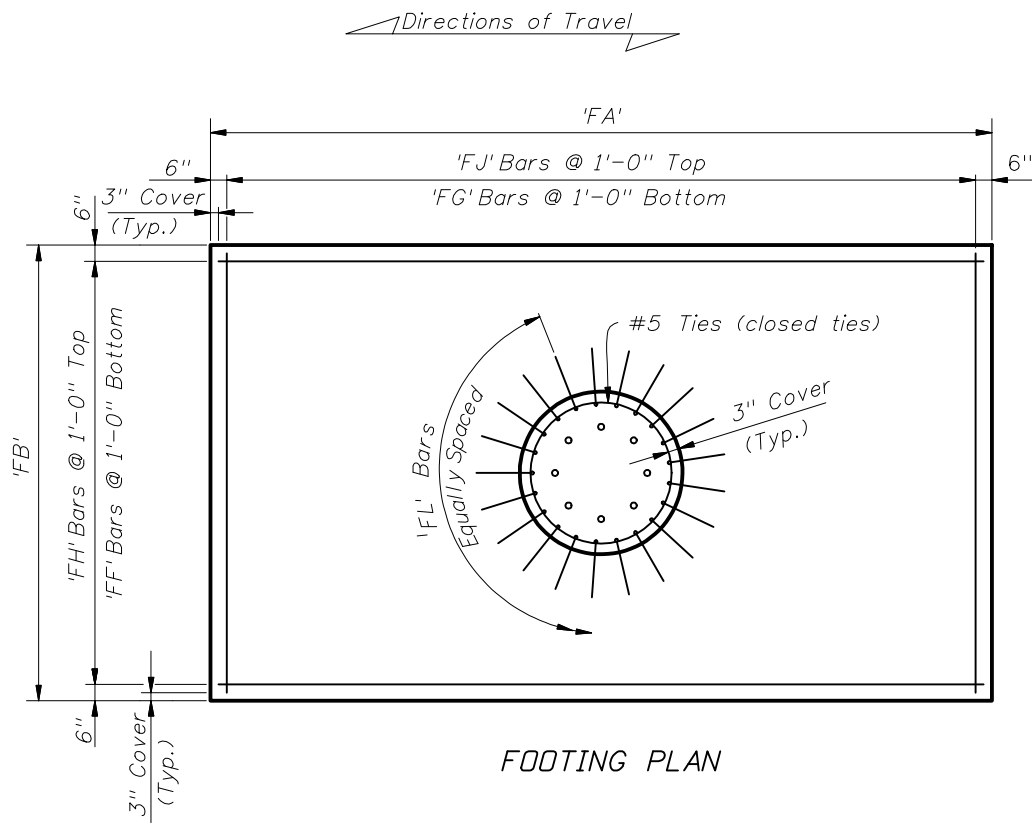

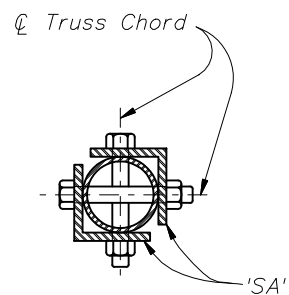

SECTION D-D

'SC' ϕ Bolts 'SB' Required
(One Half Each Side of Splice)

NOTE: Only 6 Bolts
shown for clarity

Maximum Gap Between
Pipes is $\frac{1}{8}$ "

$1\frac{3}{4}$ " for 1" ϕ Bolts
 $1\frac{1}{2}$ " for $\frac{7}{8}$ " ϕ Bolts
 $1\frac{1}{4}$ " for $\frac{3}{4}$ " ϕ Bolts

$3\frac{1}{2}$ " for 1" ϕ Bolts
3" for $\frac{7}{8}$ " ϕ Bolts
 $2\frac{1}{2}$ " for $\frac{3}{4}$ " ϕ Bolts

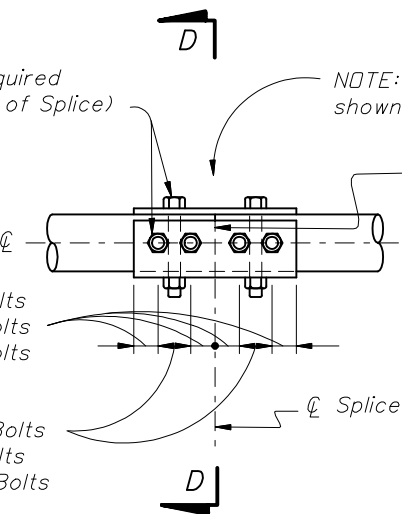

SPLICE CONNECTION DETAIL

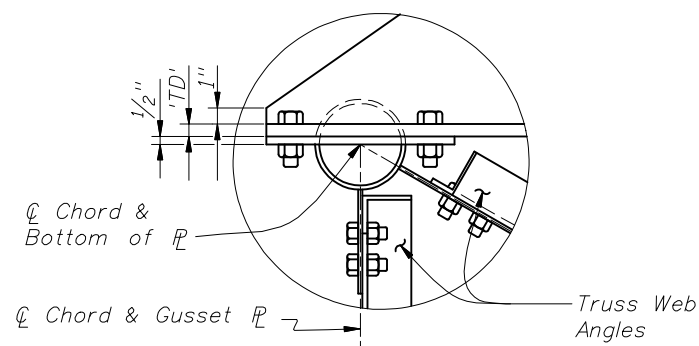

DETAIL H

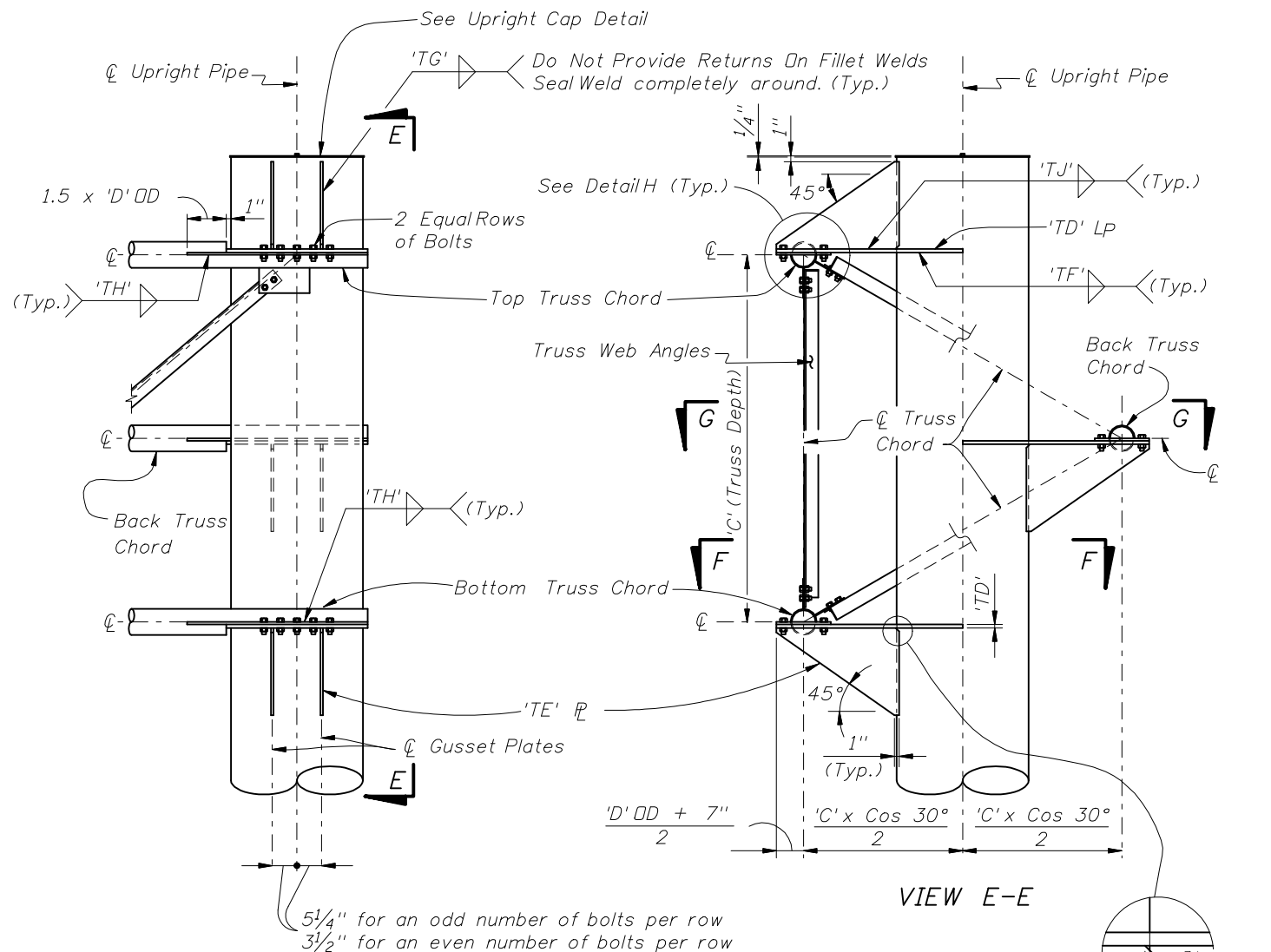

UPRIGHT-TRUSS CONNECTION DETAIL
(Web Members from back Truss Chord omitted for clarity)

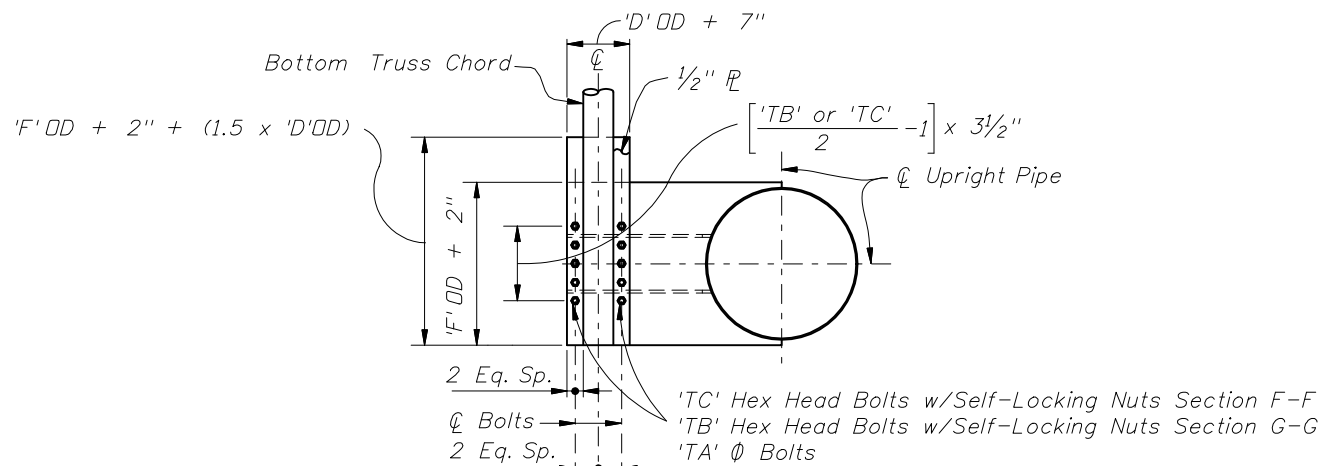

SECTION F-F, SECTION G-G SIMILAR
(With Gusset Plate & Angles omitted for clarity)

NOTE:
Abbreviation
OD ~ Outside Diameter



2010 FDOT Design Standards

CANTILEVER SIGN STRUCTURE

Last
Revision
07/01/05

Sheet No.
3 of 5

Index No.
11310

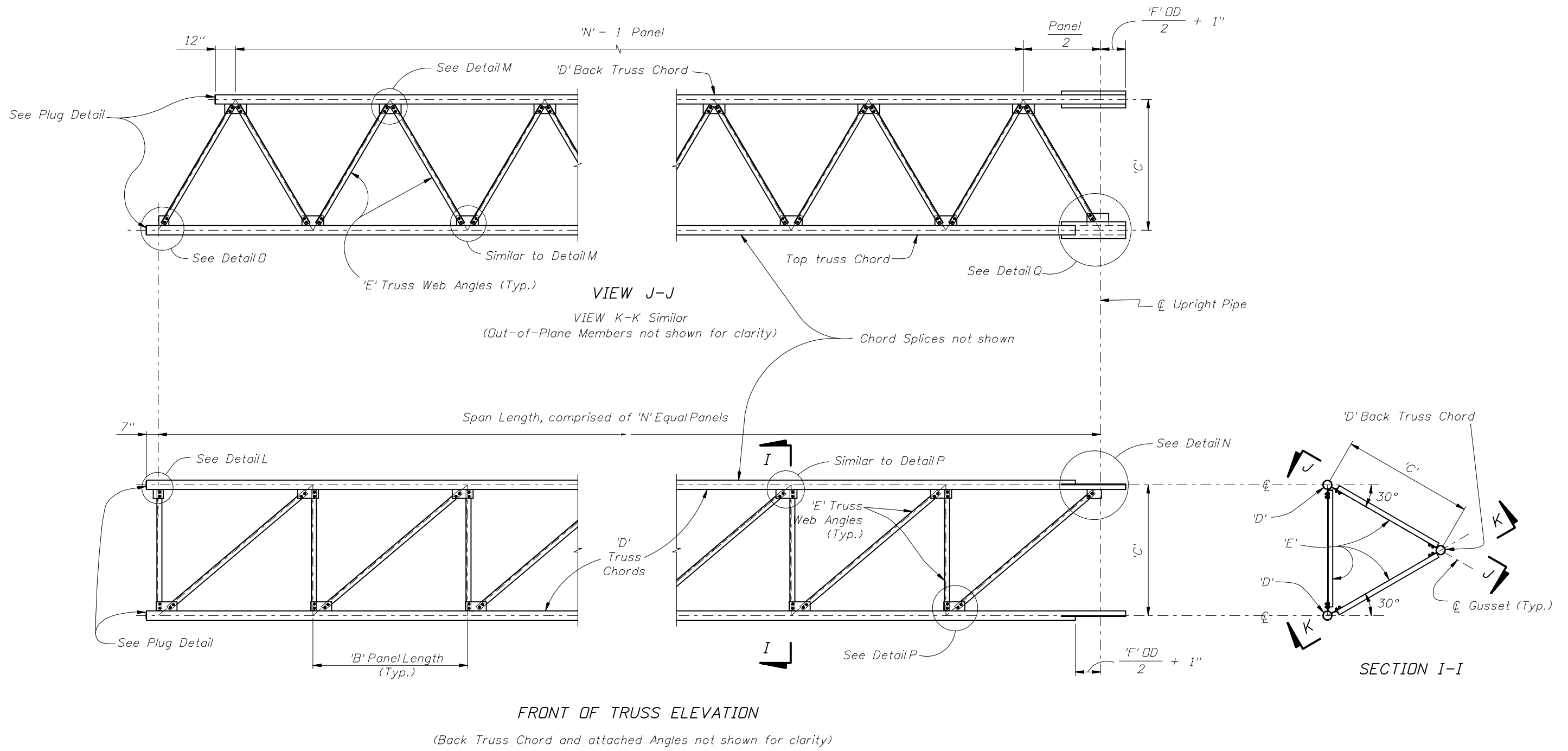

NOTE:
Abbreviation
OD ~ Outside Diameter



2010 FDOT Design Standards

CANTILEVER SIGN STRUCTURE

Last Revision	Sheet No.
07/01/05	4 of 5
Index No.	
11310	

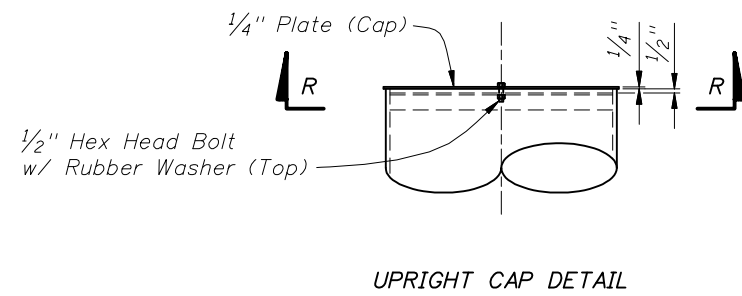
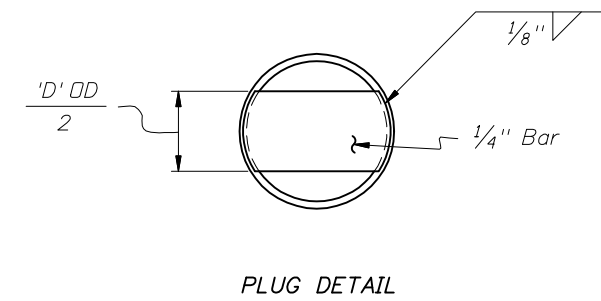
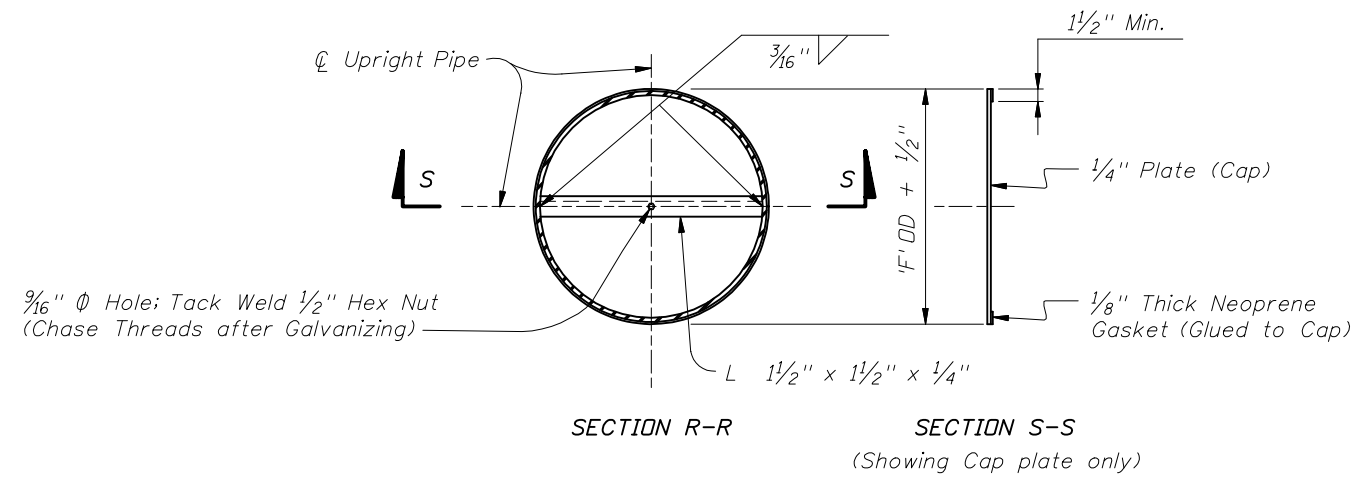
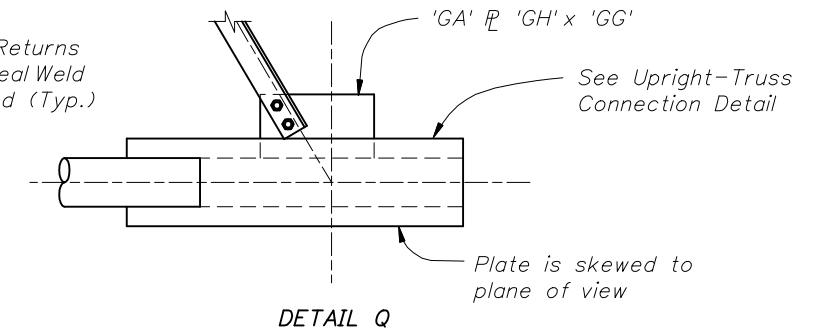
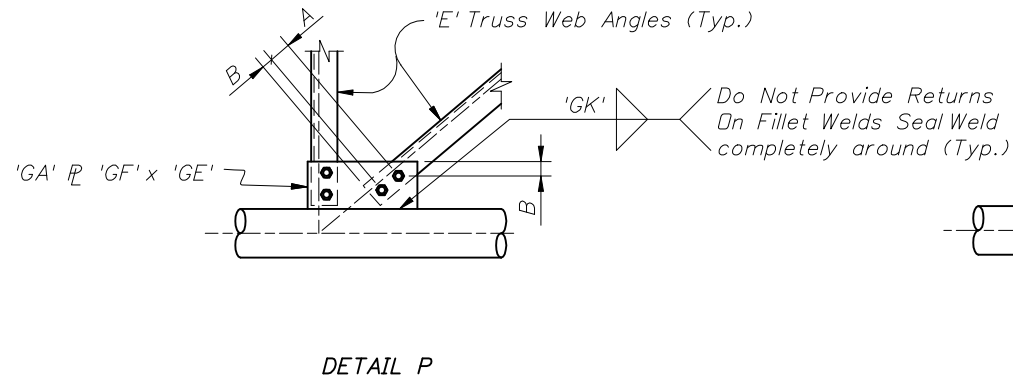
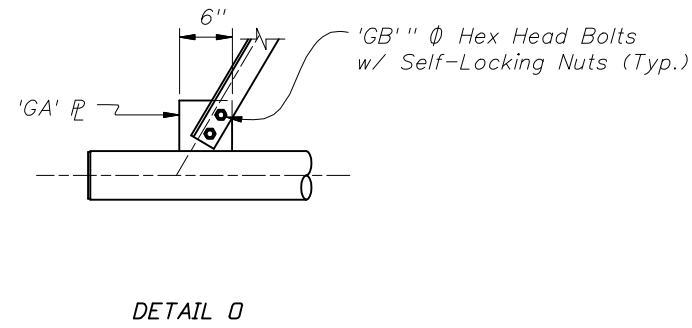
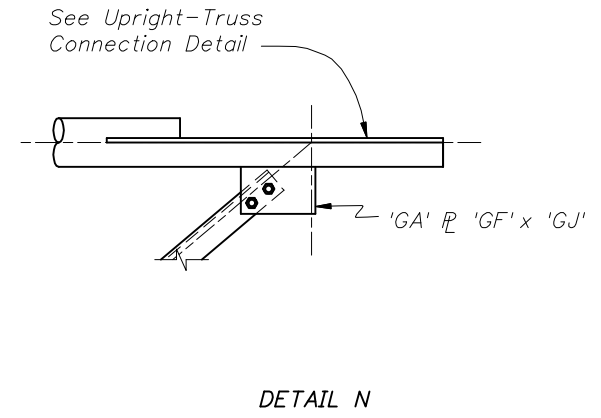
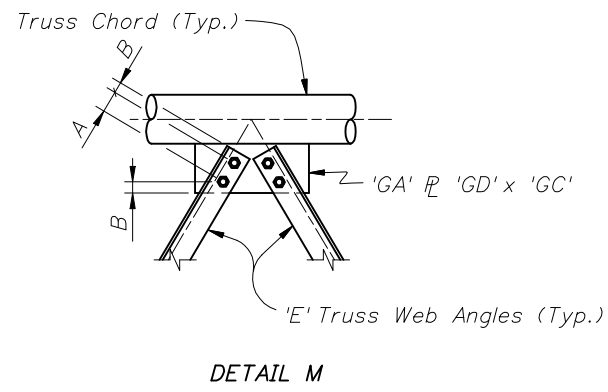
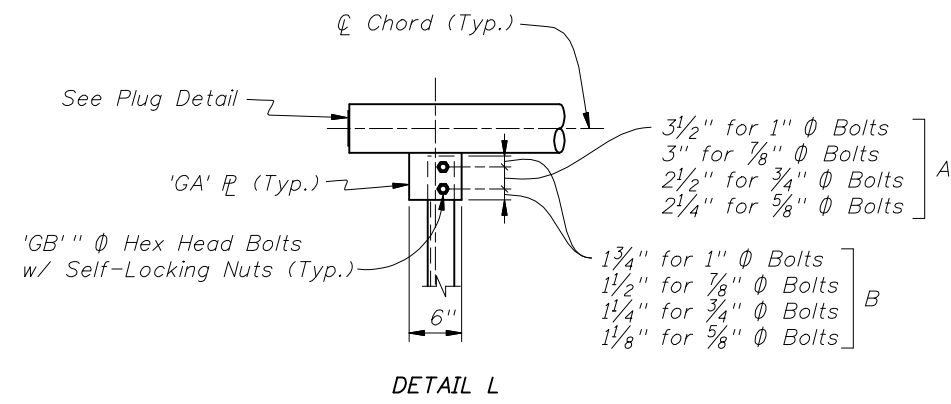

NOTE:
Abbreviation
OD ~ Outside Diameter



2010 FDOT Design Standards

CANTILEVER SIGN STRUCTURE

Last Revision	Sheet No.
01/01/09	5 of 5
Index No.	
11310	

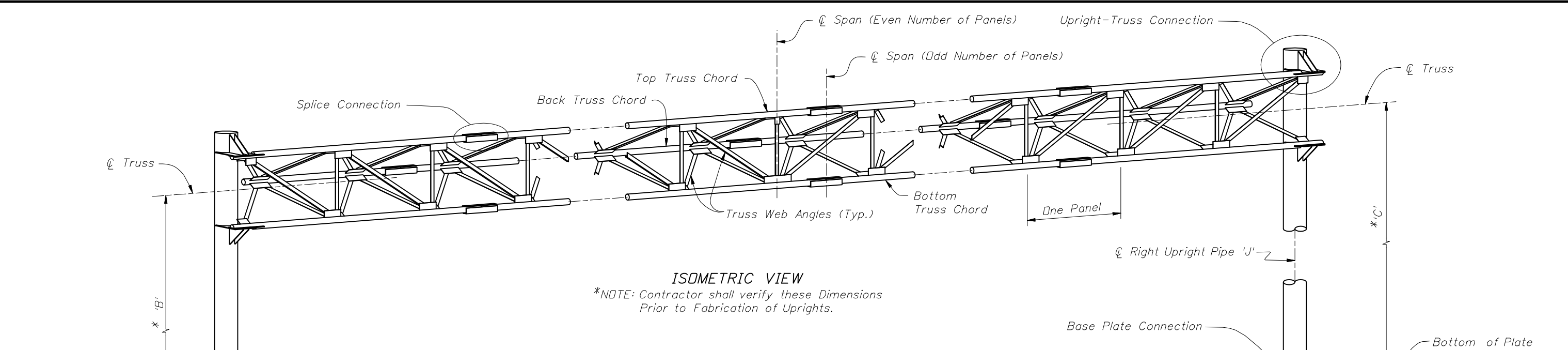

ISOMETRIC VIEW

*NOTE: Contractor shall verify these Dimensions Prior to Fabrication of Uprights.

SPAN SIGN STRUCTURE NOTES

- 1) Design according to FDOT Structures Manual. Alternate Designs are not allowed.
- 2) Submit shop drawings for all work. Include:
 - a. Field verification of all upright heights.
 - b. Foundation elevations necessary to insure minimum vertical clearances as per traffic plans.
 - c. Anchor bolt orientation with respect to centerline of truss and the direction of traffic.
 - d. The method to be used to provide the required parabolic camber. (See Camber Diagram)
- 3) Shop Fabrication, Assembly, Handling and Shipping:
 - a. Do not begin fabrication before receiving shop drawing approval.
 - b. Welding: Conform to American Welding Society Structural Welding Code (Steel) ANSI/AWS D1.1 (current edition).
 - c. Shop assemble the entire structure after galvanizing and prior to shipment.
 - d. If necessary, disassemble and secure components for shipment.
- 4) Sign Structure Materials:
 - a. Upright and Chords (Steel Pipe): API -5L-X42 (42 ksi yield) or ASTM A500, Grade B.
 - b. Steel Angles: ASTM A 709, Grade 36.
 - c. Steel Plates: ASTM A 709, Grade 36.
 - d. Weld Metal: E70XX.
 - e. Bolts: ASTM A325 Type 1, (install per Specification Section 700) with single, self-locking nuts.
 - f. Anchor Bolts: ASTM F1554, Grade 55 with ASTM A563 Grade A heavy-hex double nuts.
 - g. Install all nuts per manufacturer's instructions.
 - h. Bolt hole diameters: equal to the bolt diameter plus 1/16".
 - i. Anchor bolt hole diameters: equal to the bolt diameter plus 1/2".
- 5) Galvanization: Nuts, bolts and washers: ASTM F2329. Other steel items: ASTM A123
- 6) Sign Panels: Aluminum. See Elevation drawing for sizes and locations.
- 7) Foundation Materials:
 - a. Reinforcing Steel: ASTM A615, Grade 60.
 - b. Concrete: Class IV (Drilled Shaft), minimum 4.0 ksi compressive strength at 28-days for all environmental classifications.
- 8) Construct the Sign Structure foundation in accordance with FDOT Specification Section 455.
- 9) Prior to erection, record the as-built anchor locations and provide to the Engineer.
- 10) Provide a parabolic camber with the maximum upward deflection as shown on the Camber Diagram.
- 11) Locate Chord splices a minimum of 3 truss panel lengths apart. Chord splices may be either the Standard splice or the Alternate splice but not both on this structure. Upright splices are not allowed.
- 12) Install sign panels as shown on the Elevation drawing.
- 13) Payment: All costs associated with the Sign Structure, Sign Panels, Foundation and all incidental items will be paid for under the Sign Structure pay item.
- 14) Verify CSL access tubes will not interfere with anchor bolt installation before excavating the shaft. When CSL access tube locations conflict with anchor bolt locations, move the CSL access tube location ± two inches along the inner circumference of the reinforcing cage. Notify the Engineer before excavating the shaft if the CSL access tube locations cannot be moved out of conflict with anchor bolt locations

NOTE: See Plans for Span Sign Structure Data Table.

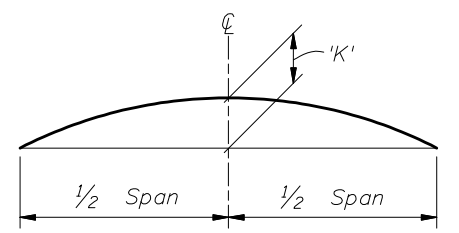

CAMBER DIAGRAM

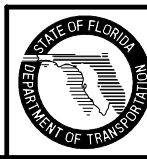

2010 FDOT Design Standards

SPAN SIGN STRUCTURE

Last Revision	Sheet No.
01/01/09	1 of 5
Index No.	
11320	

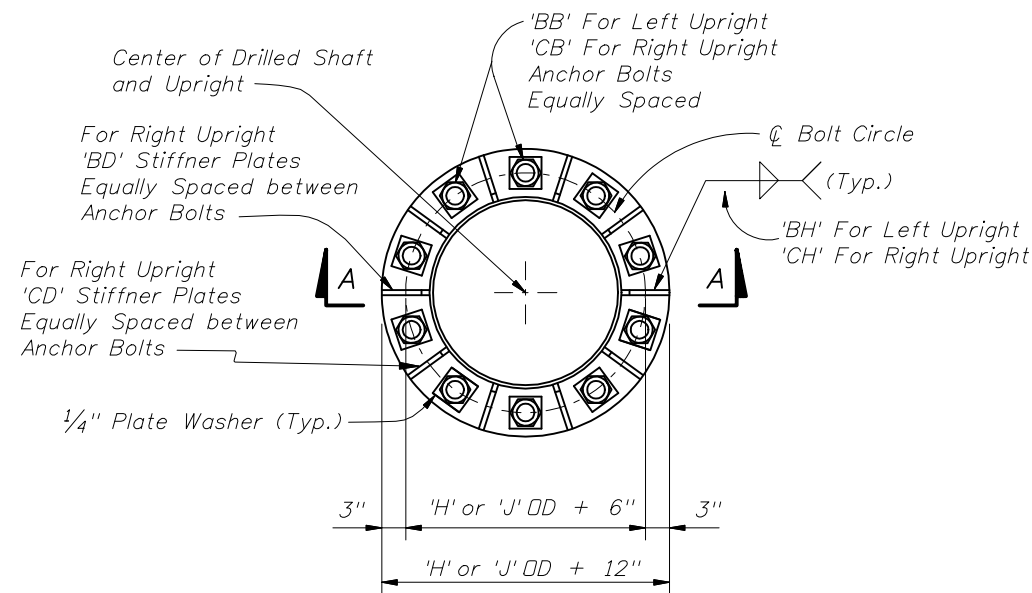

PLAN VIEW
BASE PLATE

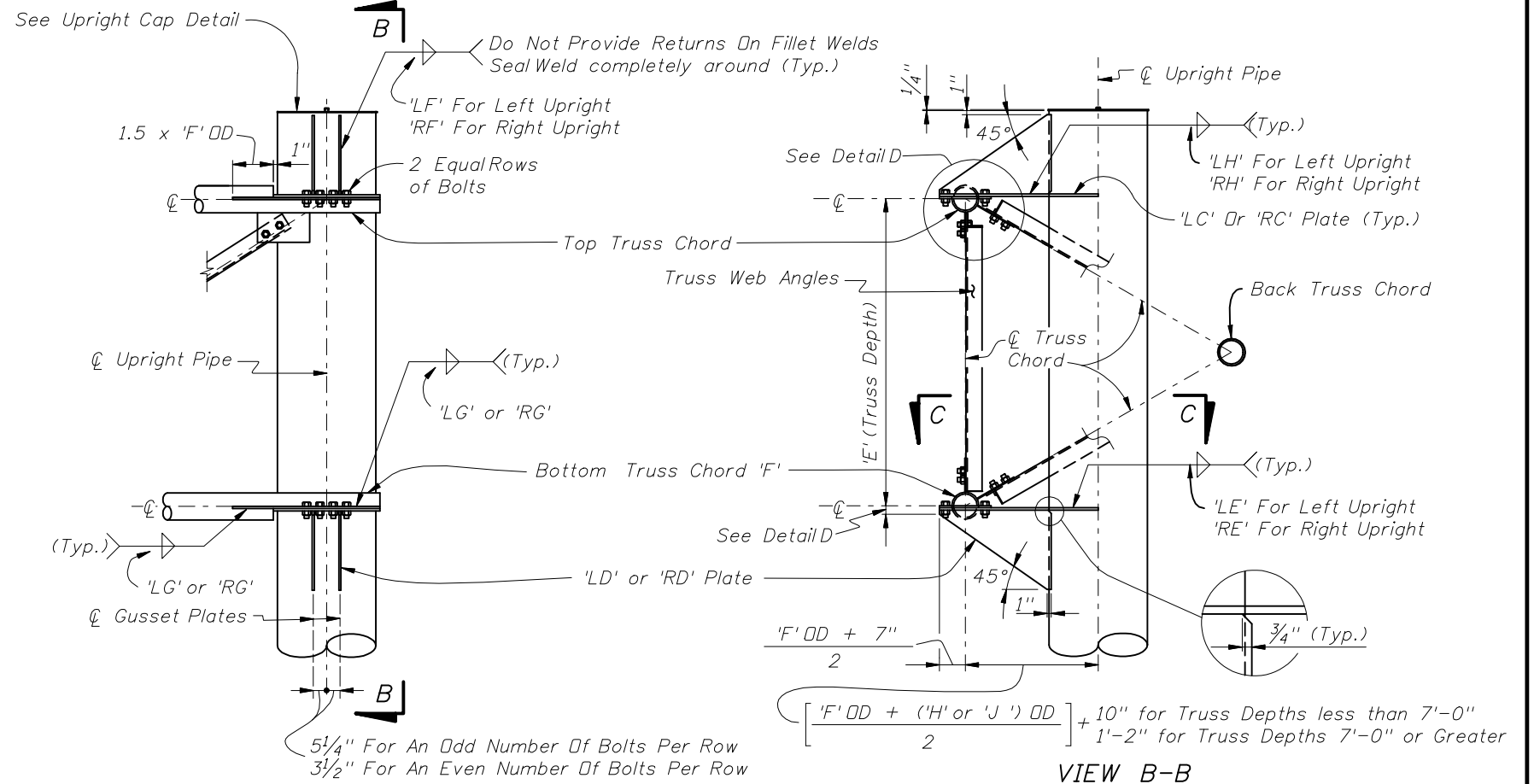

RIGHT UPRIGHT-TRUSS CONNECTION DETAIL
(LEFT UPRIGHT -TRUSS CONNECTION SIMILAR)

Web Members From Back Truss
Chord Omitted For Clarity

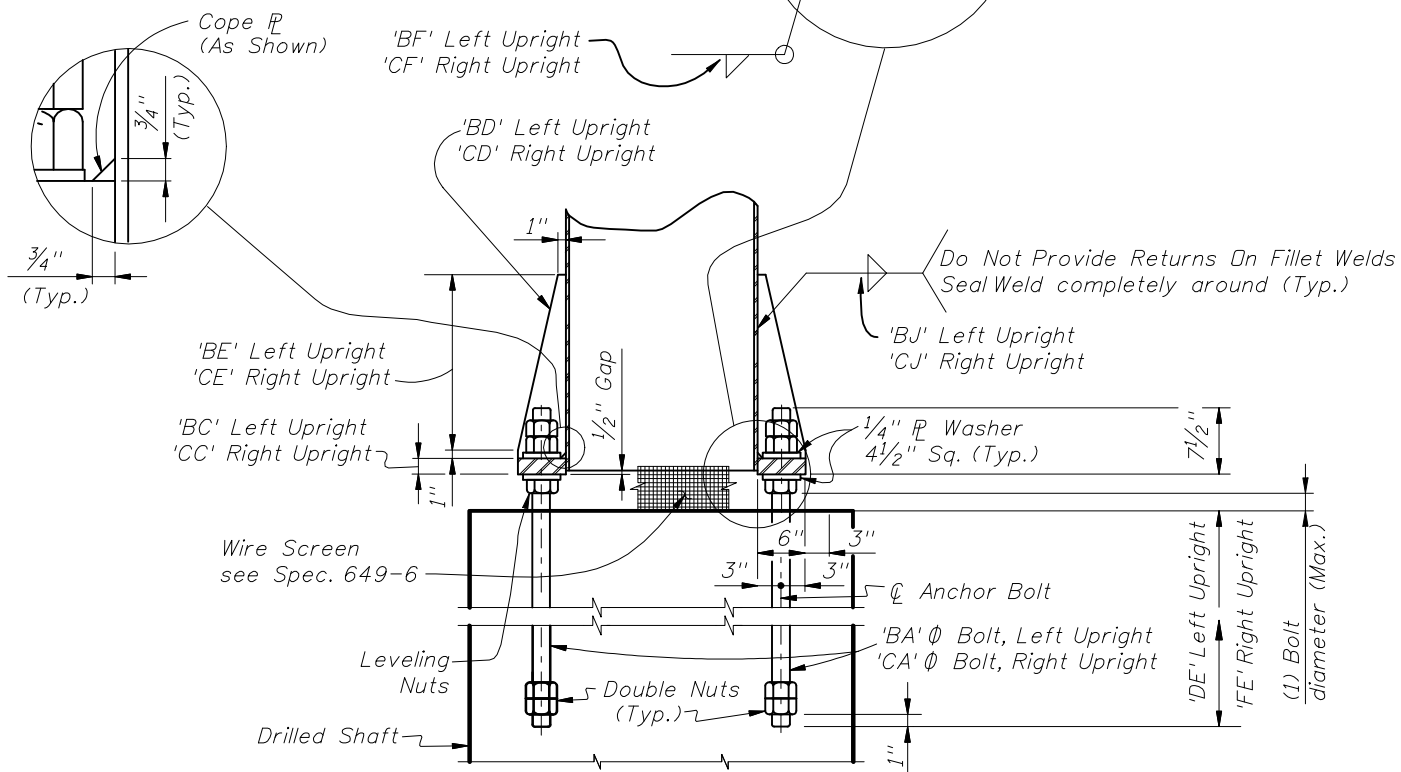

SECTION A-A

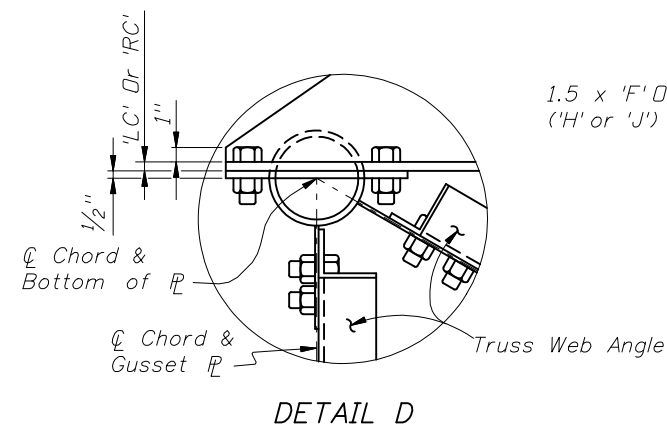

DETAIL D

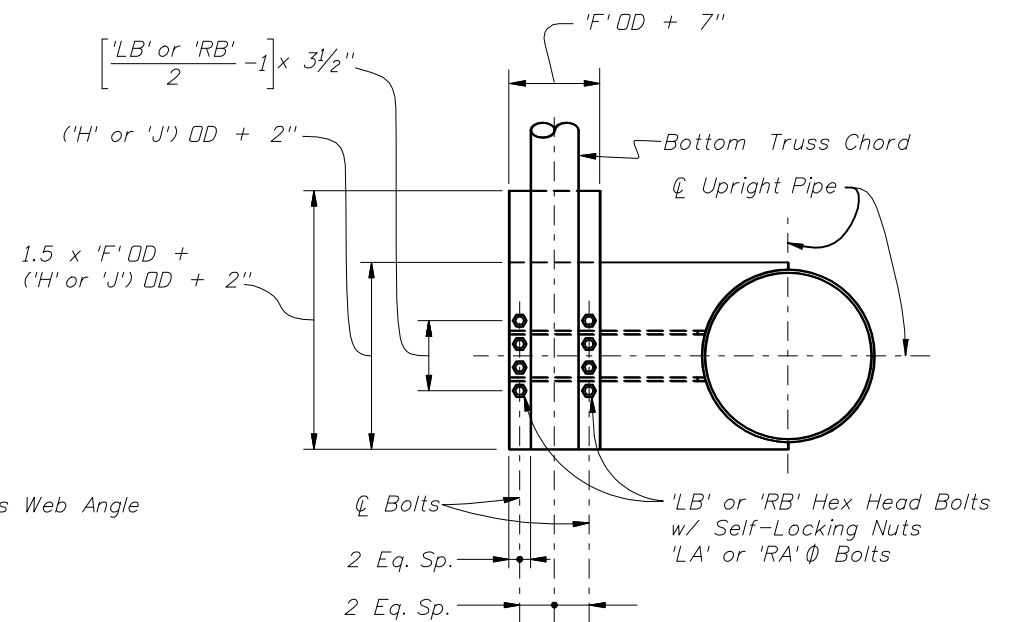

SECTION C-C

(With Gusset Plate and
Angles omitted for clarity)

NOTE:
Abbreviation
OD ~ Outside Diameter



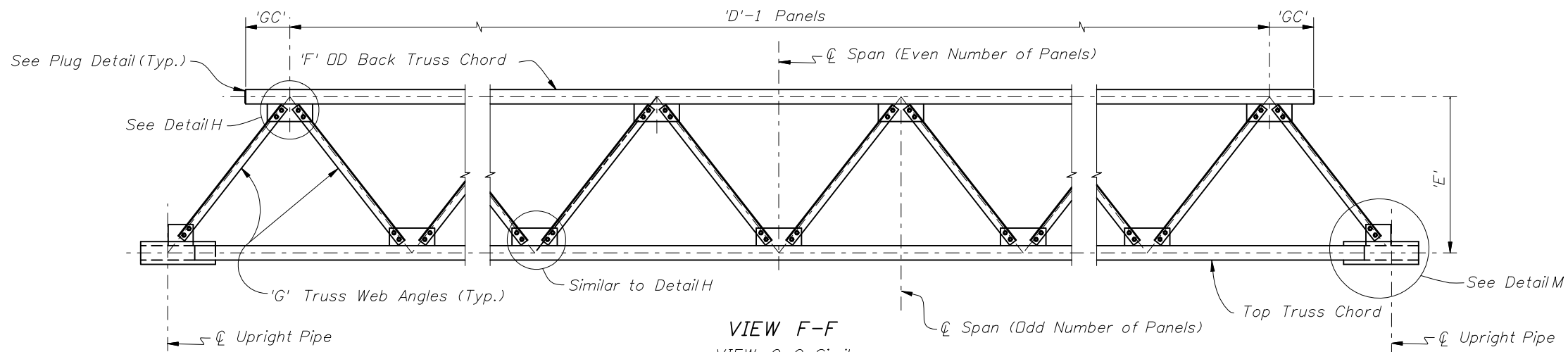

VIEW F-F

VIEW G-G Similar
(Out-of-Plane Members not shown for clarity)

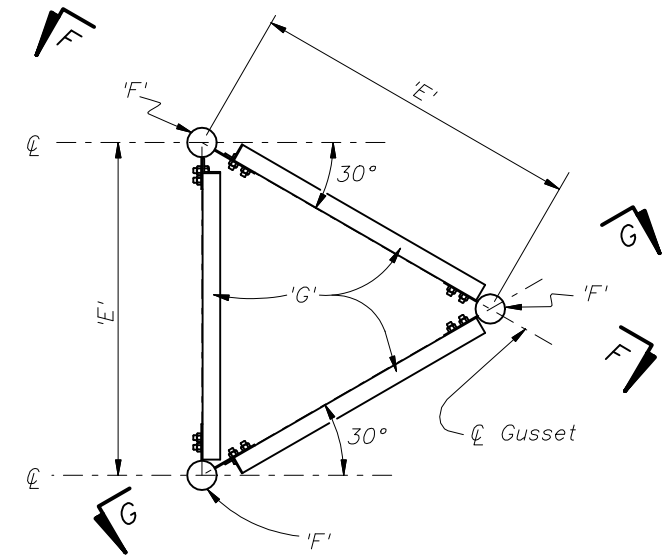

SECTION E-E

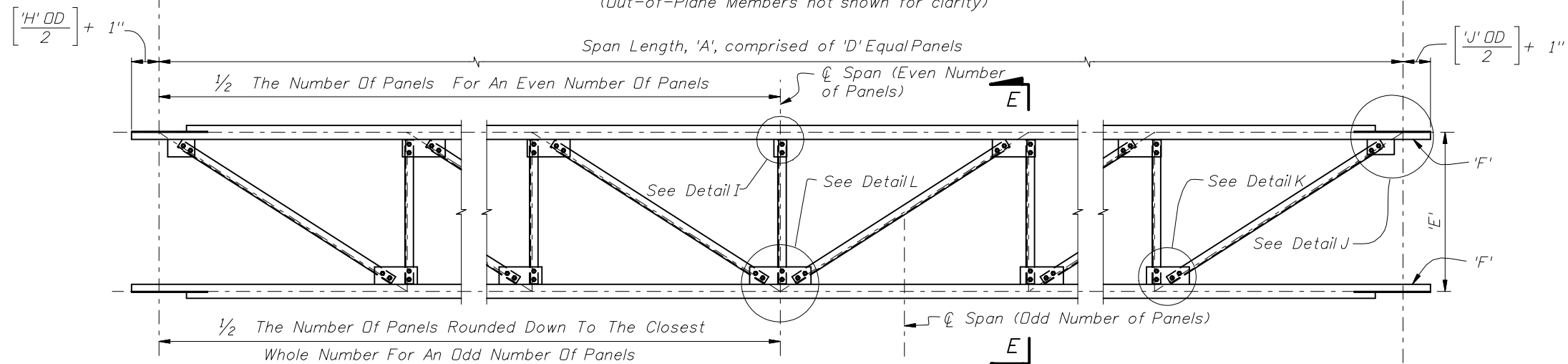

FRONT OF TRUSS ELEVATION

(Back Truss Chord and attached Angles not shown for clarity)

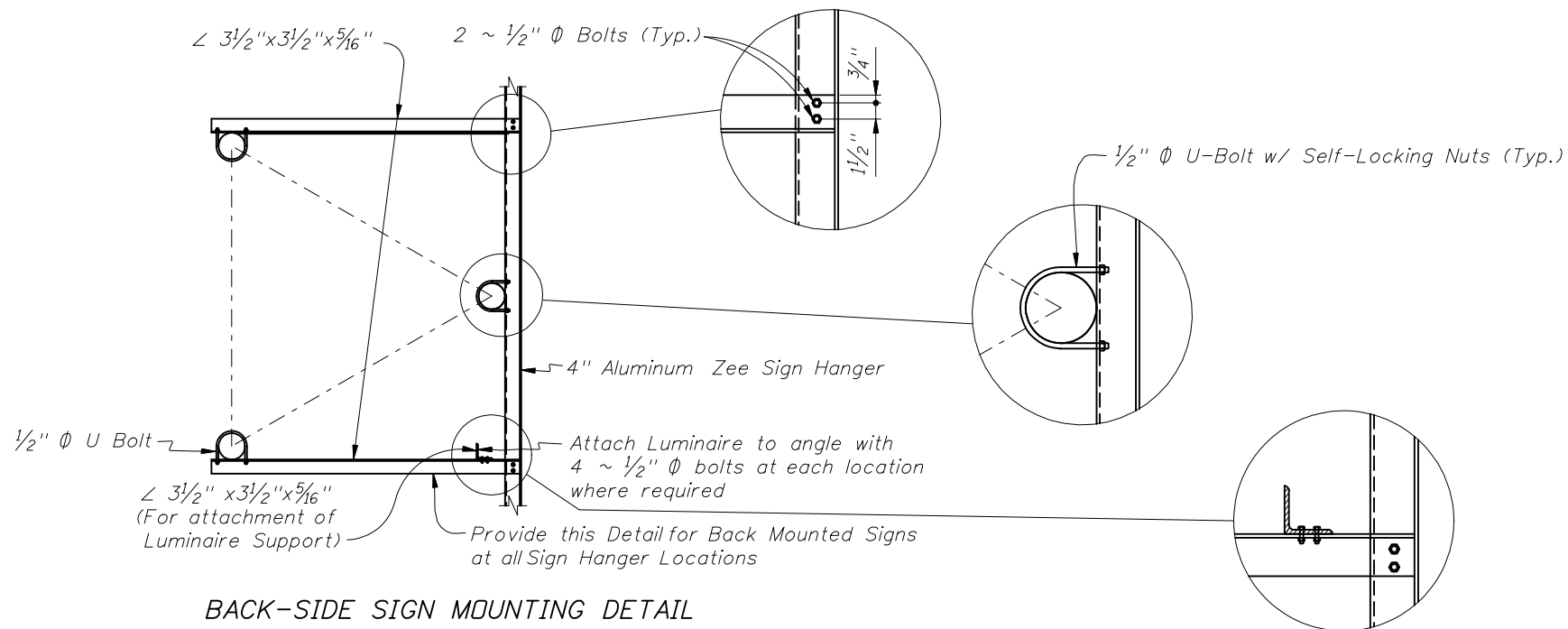

BACK-SIDE SIGN MOUNTING DETAIL

NOTE: See Index No. 11300.

NOTE:
Abbreviation
OD ~ Outside Diameter

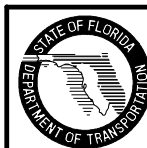

2010 FDOT Design Standards

SPAN SIGN STRUCTURE

Last Revision	Sheet No.
07/01/05	3 of 5
Index No.	
11320	

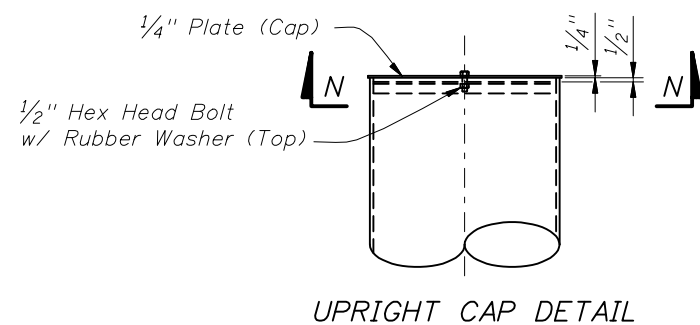
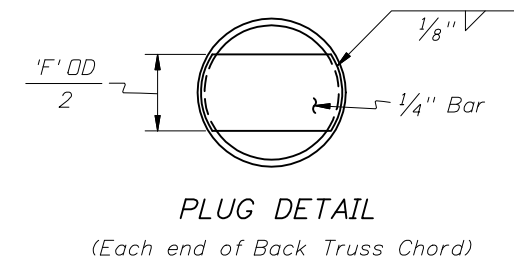
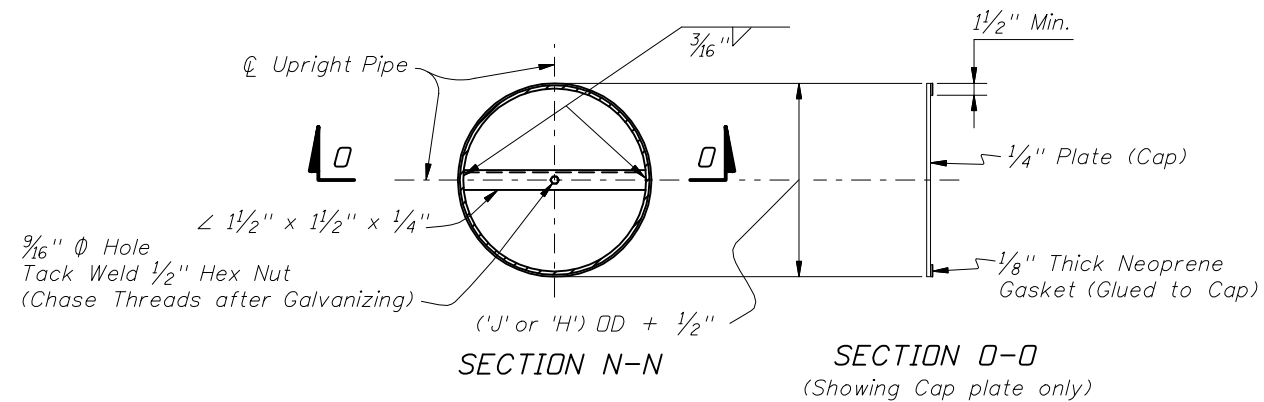
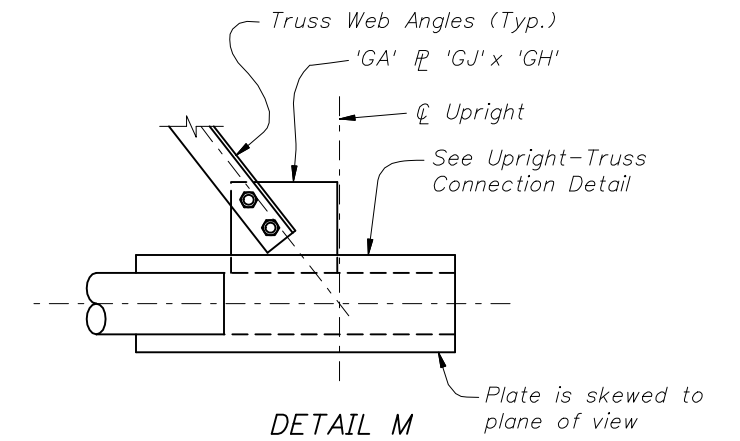
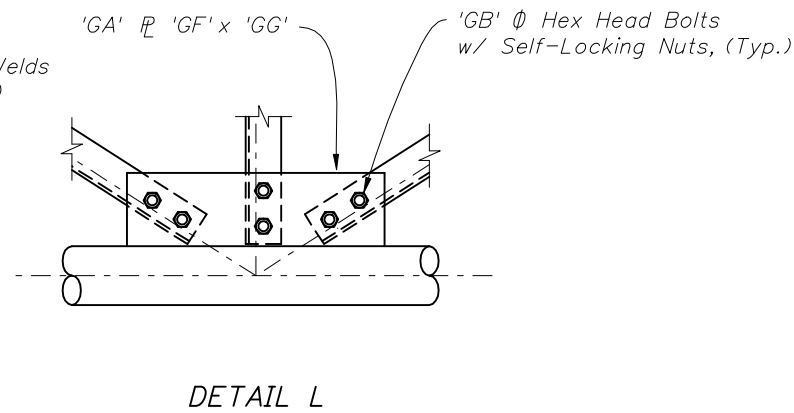
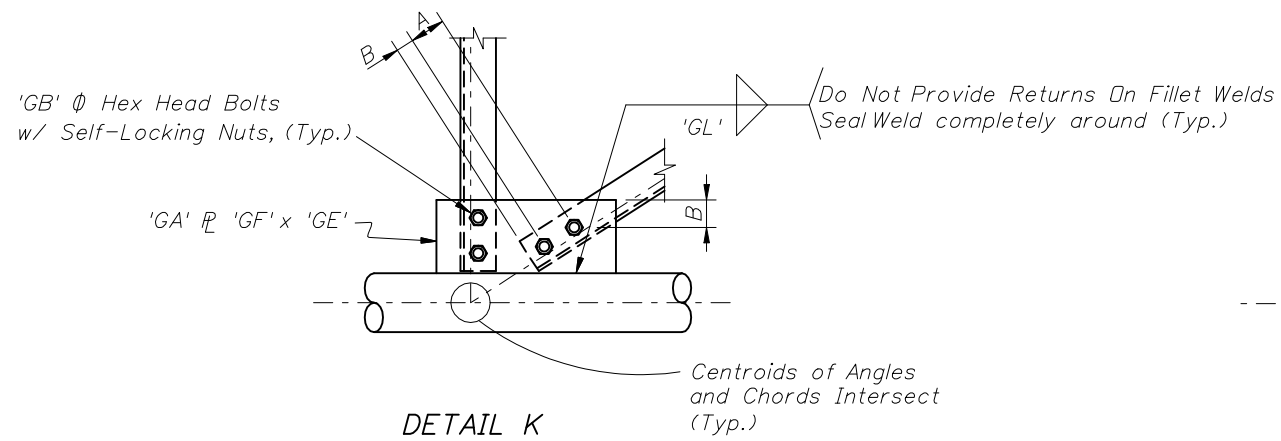
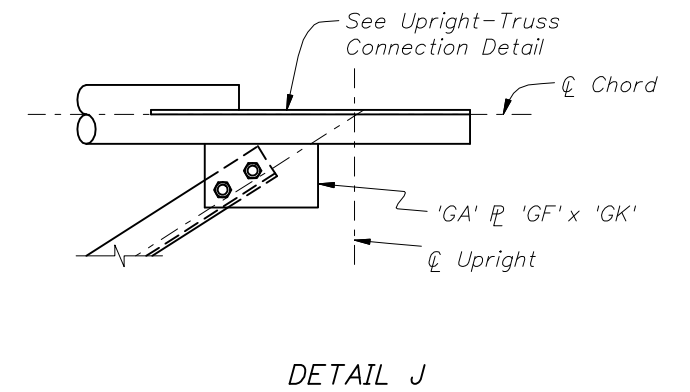
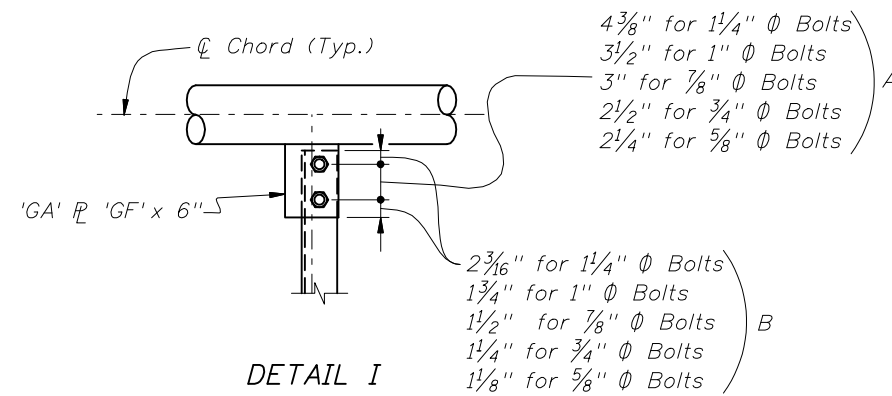
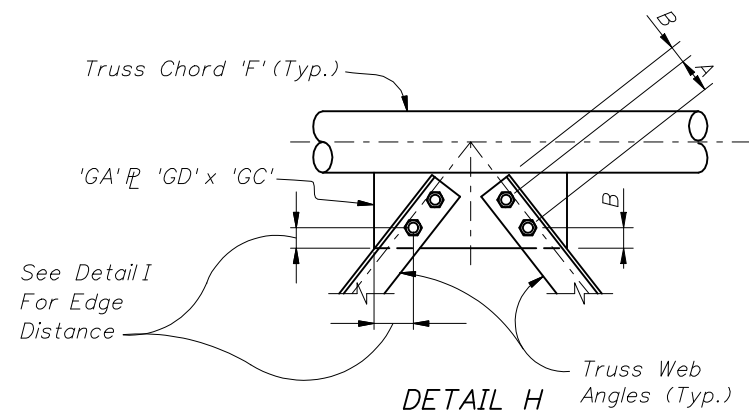

NOTE:
Abbreviation
OD ~ Outside Diameter



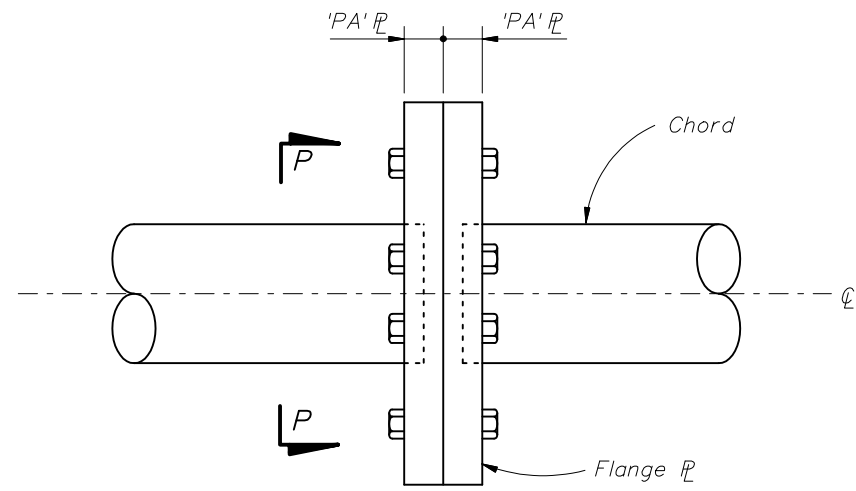

ELEVATION
ALTERNATE SPLICE CONNECTION

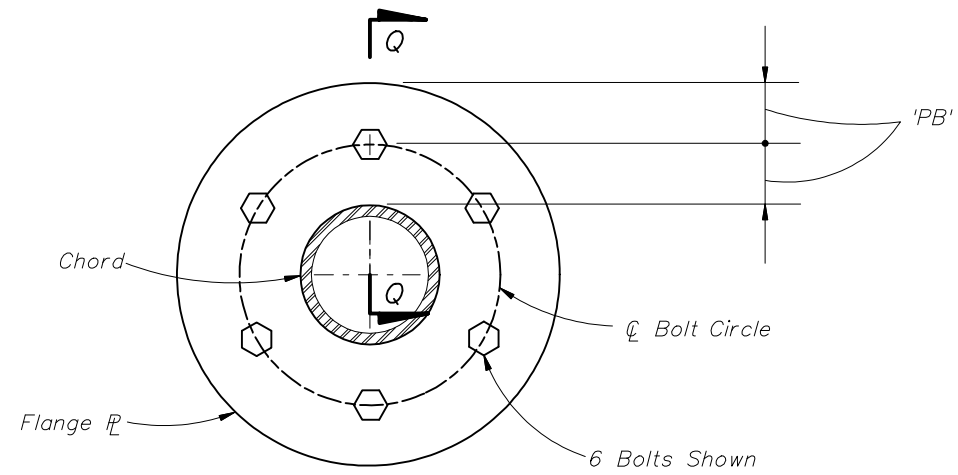

SECTION P-P

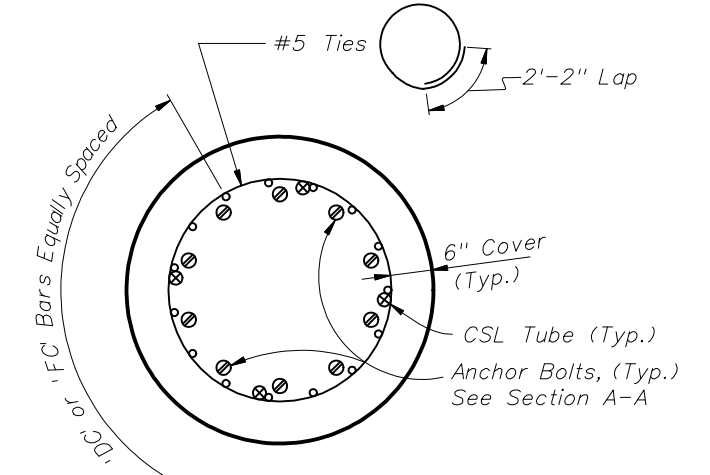

PLAN VIEW
DRILLED SHAFT

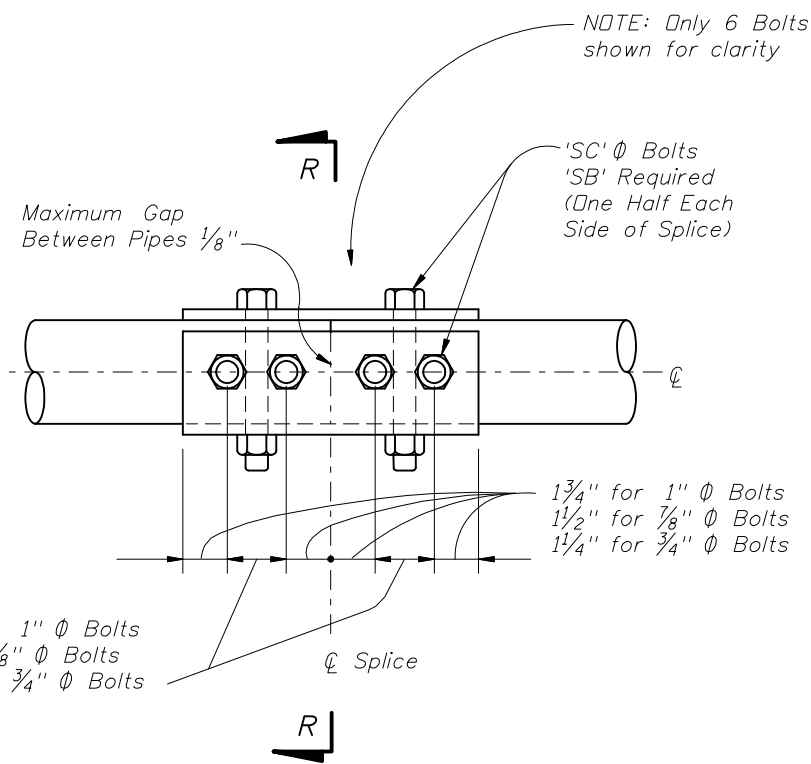

ELEVATION
SPLICE CONNECTION

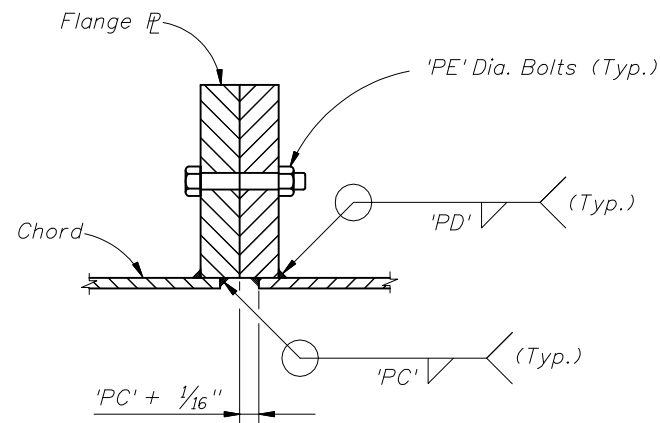

SECTION Q-Q

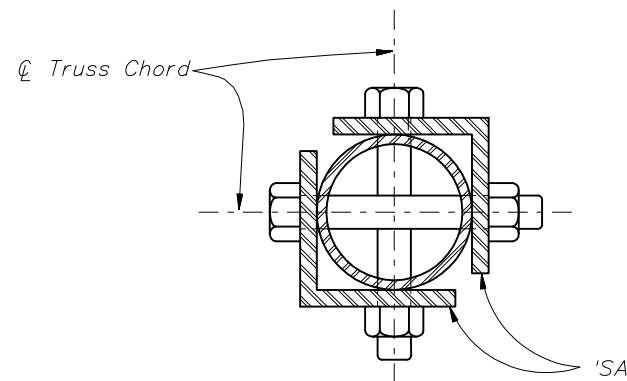

SECTION R-R

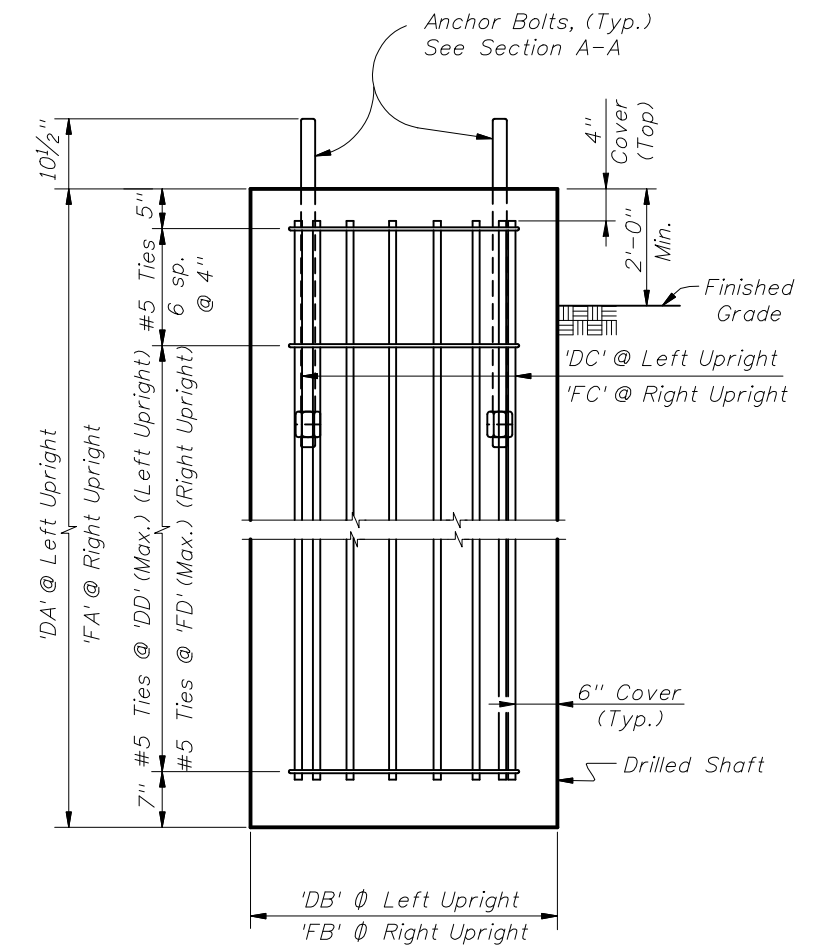

ELEVATION
DRILLED SHAFT



SINGLE COLUMN GROUND SIGN NOTES:

- 1) DESIGN WIND SPEED: See Wind Speeds by County.
- 2) GENERAL SPECIFICATIONS: Current FDOT Standard Specifications for Road and Bridge Construction and supplements thereto.
- 3) DESIGN SPECIFICATIONS: AASHTO Standard Specifications for Structural Supports for Highway Signs, Luminaires and Traffic Signals, as modified by the FDOT Structures Manual.
- 4) ALUMINUM: Aluminum Materials shall meet the requirements of Aluminum Association Alloy 6061-T6 (ASTM B209, B221, or B308), except as noted below.
- 5) CONCRETE: Class I.
- 6) SIGN PANELS: 0.08 inches min. thick Aluminum Plate with all corners rounded.
- 7) ALUMINUM BOLTS, NUTS, AND LOCK WASHERS:
 - a. Aluminum bolts: ASTM F468, Alloy 2042-T4 with at least 0.0002 inches thick anodic coating and chromate sealed.
 - b. Nuts: ASTM F467, Alloy 6061-T6 or 6262-T9.
 - c. Lockwashers: ASTM B221, Alloy 7075-T6.
- 8) STAINLESS STEEL BOLTS, NUTS, AND LOCKWASHERS:

Stainless Steel Bolts, Nuts, and Lockwashers: ASTM F593 and ASTM F594, Alloy Group 2. Condition A, CW2, or SH4 may be provided in lieu of Aluminum Bolts, Nuts, and Washers.
- 9) U-BOLTS, NUTS, AND LOCKWASHERS:

U-bolts, Nuts, and Lockwashers: ASTM A307, Grade A, galvanized in accordance with ASTM F2329.
- 10) BREAKAWAY SUPPORTS REQUIREMENTS: Install non-frangible aluminum column (post) (larger than 3 1/2") with breakaway supports as shown on Sheet 5 of 8. Signs shielded by barrier wall or guardrail do not require breakaway support.
- 11) QPL: Manufacturers seeking approval of alternates to aluminum round tube, such as steel U-channel and steel square tube single post ground sign assemblies for inclusion on the Qualified Products List (QPL), must submit a QPL application, design calculations, detailed drawings and design tables showing the product meets all the requirements.

WIND SPEEDS BY COUNTY:

- 110 MPH**
Alachua, Baker, Bradford, Clay, Columbia, Gadsden, Gilchrist, Hamilton, Hardee, Jackson, Jefferson, Lafayette, Lake, Leon, Madison, Marion, Polk, Putnam, Sumter, Suwannee and Union counties.
- 130 MPH**
Bay, Brevard, Calhoun, Charlotte, Citrus, De Soto, Dixie, Duval, Flagler, Franklin, Glades, Gulf, Hendry, Hernando, Highlands, Hillsborough, Holmes, Lee, Levy, Liberty, Manatee, Nassau, Okaloosa, Okeechobee, Orange, Osceola, Pasco, Pinellas, Sarasota, Seminole, St Johns, Taylor, Volusia, Wakulla, Walton and Washington counties.
- 150 MPH**
Broward, Collier, Dade, Escambia, Indian River, Martin, Monroe, Palm Beach, Santa Rosa and St. Lucie counties.

GUIDE TO USE THIS STANDARD:

1. Calculate the area and the centroid for an individual sign or a sign cluster. Note that the centroid and areas have been calculated for frequently used sign clusters. These are shown on Sheet No. 6, 7 & 8 of 8.
2. Determine the height 'H' from groundline for the individual sign or the cluster.
3. Select the appropriate Column (Post) Selection Tables by Wind Speed and find the intersection point.
4. Design the post and the foundation according to the dark-bold lines or shaded area (if cantilever sign) in the Column (Post) Selection Tables and Post and Foundation Table. For sign posts with signs oriented in two directions, only the sign with the largest area should be analyzed to determine the post requirements.

EXAMPLE:

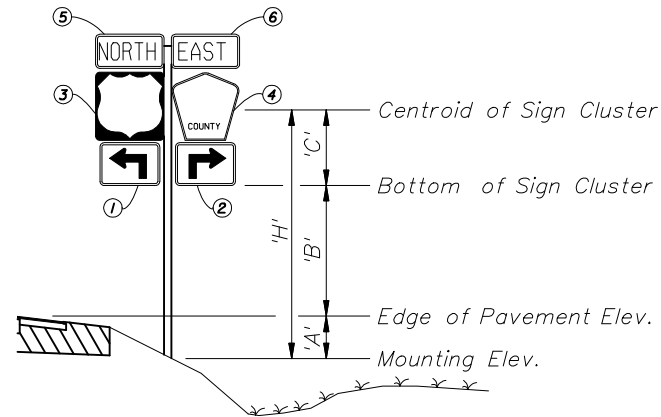

Size H x V	Centroid			'A _n '	'X _n ' x 'A _n '	'Y _n ' x 'A _n '	
	local 'Y _n '	global 'X _n '	global 'Y _n '				
(IN x IN)	(IN)	(IN)	(IN)	(IN ²)	(IN ³)	(IN ³)	
① 21 x 15	7.5	-10.5-1.5-1.5 = -13.5	7.5	315	-4,252.5	2,362.5	
② 21 x 15	7.5	10.5+1.5+1.5 = 13.5	7.5	315	+4,252.5	2,362.5	
③ 24 x 24	12	-12-1.5 = -13.5	15+1+12= 28	576	-7,776	16,128	
④ 24 x 24	12	12+1.5 = 13.5	15+1+12= 28	436	5,886	12,208	
⑤ 24 x 12	6	-12-1.5 = -13.5	15+1+24+ 1+6=47	288	-3,888	13,536	
⑥ 24 x 12	6	12+1.5 = 13.5	15+1+24+ 1+6=47	288	3,888	13,536	
				2,218	-1,890	60,133	TOTALS

$\Sigma('A_n') = 2,218 \text{ IN}^2 = 15.4 \text{ FT}^2$ $\Sigma('X_n' \times 'A_n') = -1,890 \text{ IN}^3 = -1.09 \text{ FT}^3$ $\Sigma('Y_n' \times 'A_n') = 60,133 \text{ IN}^3 = 34.8 \text{ FT}^3$

$'X'_c = \frac{\Sigma('X_n' \times 'A_n')}{\Sigma('A_n')} = -0.1 \text{ FT}$ $'Y'_c = \frac{\Sigma('Y_n' \times 'A_n')}{\Sigma('A_n')} = 2.26 \text{ FT}$

Assume: Bay County, 'A' = 1 FT, 'B' = 7 FT
 Calculated: 'X'_c = -0.1 FT 'C' = 'Y'_c = 2.26 FT
 Since 'X'_c < 6", it is not a cantilever sign, only dark-bold lines in the table will be referenced to.

'H' = 'A' + 'B' + 'C' = 10.26 FT ==> **USE 11 FT** $\Sigma('A_n') = 15.4 \text{ FT}^2$ ==> **USE 16 FT²**

ALUMINUM COLUMN (POST) SELECTION TABLE
(WIND SPEED = 130 MPH)

TOTAL PANEL AREA (SF)	'H' (FT)												
	8	9	10	11	12	13	14	15	16	17	18	19	20
3													
4													
5													
6													
7													
8													
9													
10													
11													
12													
13													
14													
15													
16													
17													
18													
19													
20													
21													
22													
23													
24													
25													
26													
27													
28													
29													
30													

For WIND SPEED = 130 MPH,
'H' = 11 FT, Area = 16 FT²

- Refer to the 130 mph Column (Post) Selection Table, as copied from Sheet 3 of 8 and shown here.
- Using the 16 ft² area on the left hand side of the table, go across to the 11 ft height and find the cell marked with X.
- find the symbol **4** which the dark-bold line under the X cell leads to.
- In the Post and Foundation Table, the symbol **4** concludes that the design requires a 4.0" diameter and 0.25" thick Aluminum Column (Post) and a 2.0' diameter and 4.0' deep Concrete Foundation.

= If CANTILEVER SIGN configuration (see Cantilever Sign Details) falls in this region, use next larger post size than that indicated.

NOTES AND EXAMPLE



2010 FDOT Design Standards

SINGLE COLUMN GROUND SIGNS

Last Revision 07/01/09	Sheet No. 1 of 8
Index No. 11860	

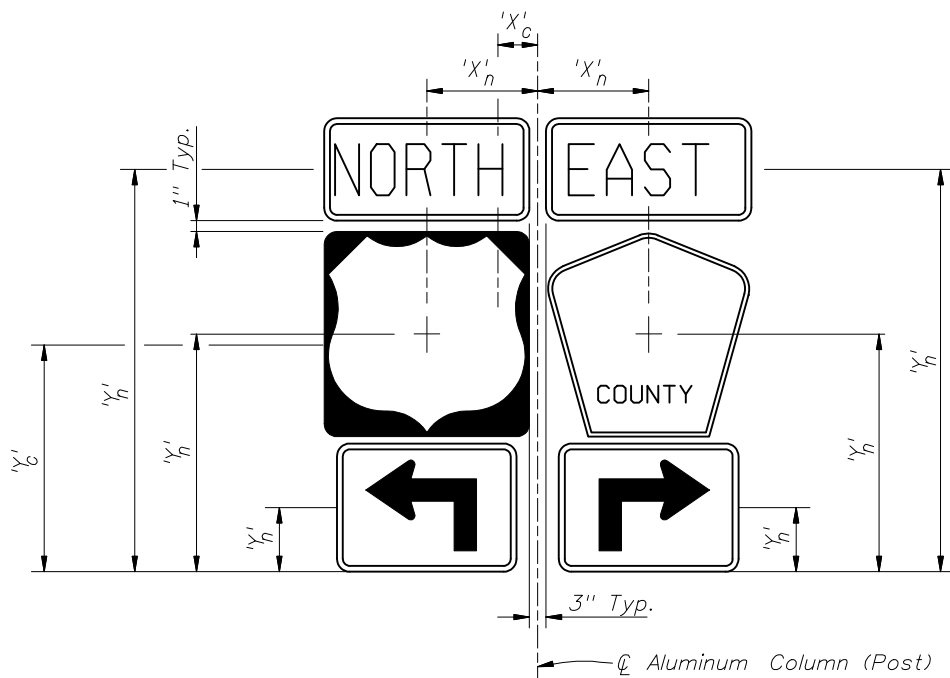

SIGN CLUSTER

CALCULATION OF SIGN CLUSTER CENTROID:

$$X'_c = \frac{\sum (X'_n \times A'_n)}{\sum A'_n}$$

$$Y'_c = \frac{\sum (Y'_n \times A'_n)}{\sum A'_n}$$

X'_c = Centroid horizontal location of sign or cluster from \varnothing Column (post)

Y'_c = Centroid height of sign or cluster from bottommost edge

H = Height of sign or cluster centroid from groundline

X'_n = Individual sign centroid horizontal location from \varnothing Column (post)

Y'_n = Individual sign centroid height from bottommost edge

A'_n = Area of individual sign

For 'A' & 'B' see Index No. 17302 and Roadway Plans.

NOTE:

No sign or sign cluster area shall exceed 30 SF nor shall any sign or sign cluster have a total width exceeding 60 inches.

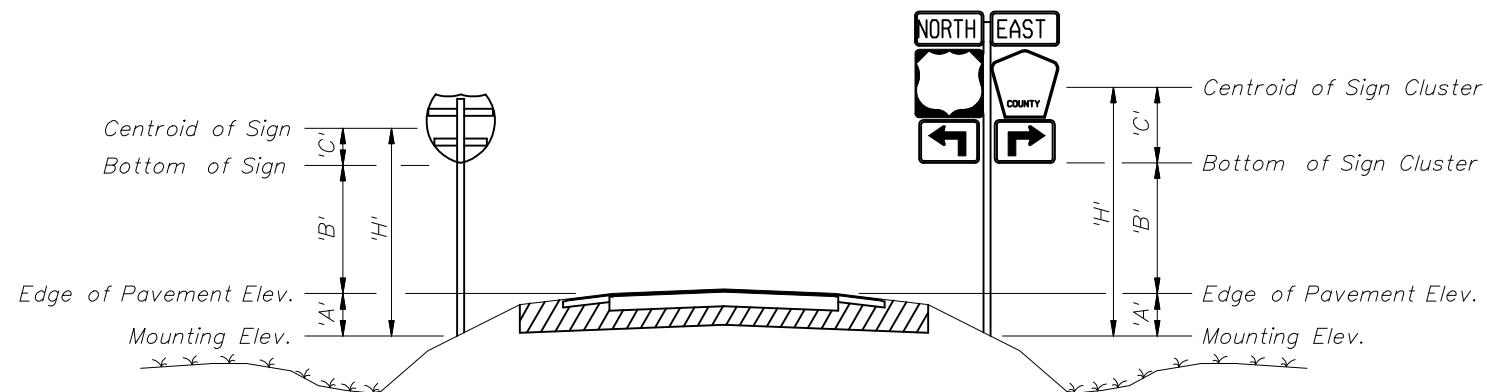

TYPICAL SECTION

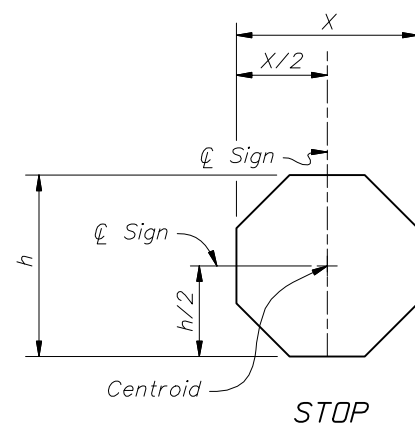

STOP

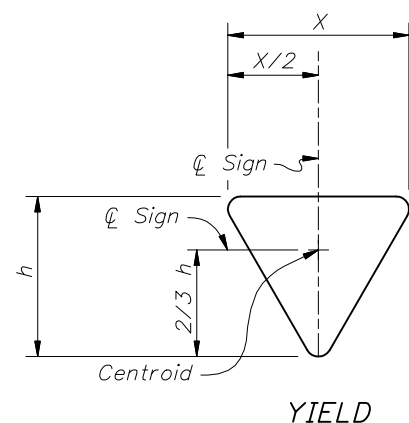

YIELD

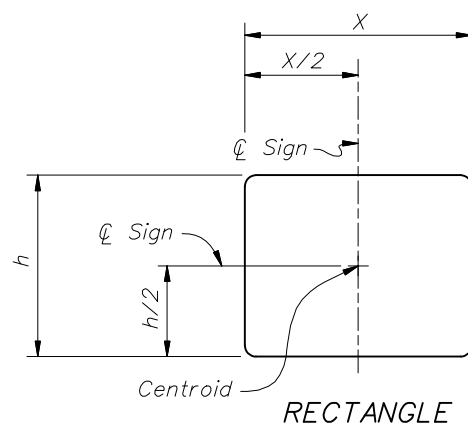

RECTANGLE

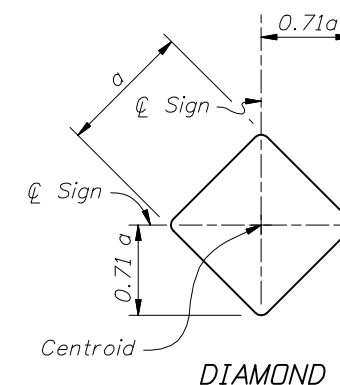

DIAMOND

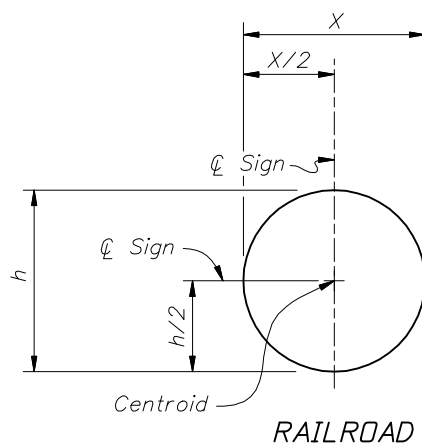

RAILROAD

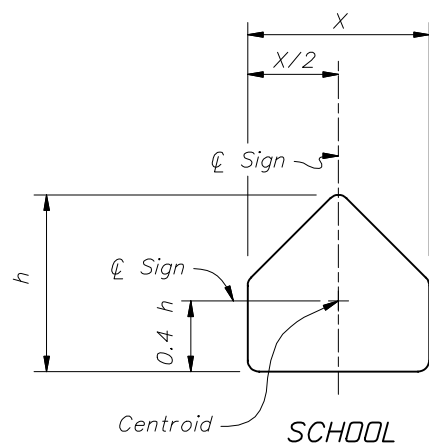

SCHOOL

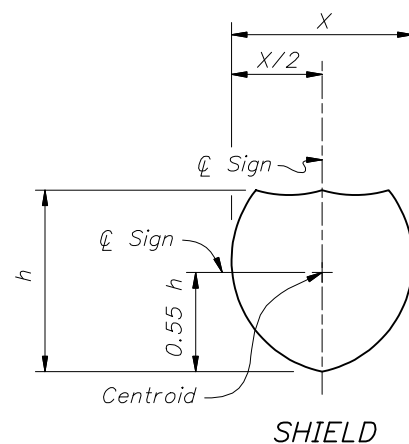

SHIELD

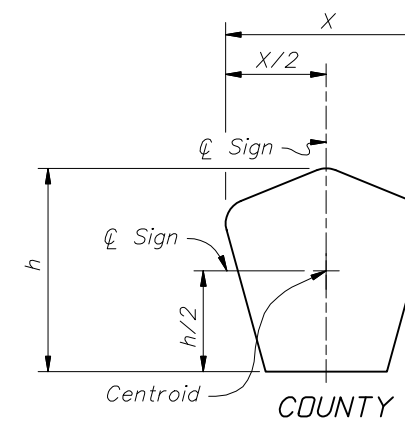

COUNTY

CENTROID AND HEIGHT



ALUMINUM COLUMN (POST) SELECTION TABLE
(WIND SPEED = 110 MPH)

TOTAL PANEL AREA (SF)	'H' (FT)												
	8	9	10	11	12	13	14	15	16	17	18	19	20
3			0			1					2		
4	1												
5												3	
6	1												
7	1												
8													
9													
10													
11												4	
12													
13													
14													
15													5
16													
17													
18													
19													6
20													
21													
22													
23													
24													
25													
26													
27													
28													
29													
30													7

ALUMINUM COLUMN (POST) SELECTION TABLE
(WIND SPEED = 130 MPH)

TOTAL PANEL AREA (SF)	'H' (FT)												
	8	9	10	11	12	13	14	15	16	17	18	19	20
3	0					1					2		
4	1												3
5													
6													
7													
8	1												4
9													
10													
11													5
12													
13													
14													6
15													
16	1												
17													
18													
19													
20													
21													
22													
23													
24													7
25													
26													
27													
28	1												
29													
30													8

ALUMINUM COLUMN (POST) SELECTION TABLE
(WIND SPEED = 150 MPH)

TOTAL PANEL AREA (SF)	'H' (FT)												
	8	9	10	11	12	13	14	15	16	17	18	19	20
3			1			2						3	
4													
5													4
6													
7													
8													
9													
10													6
11													
12													
13													
14													
15													
16													
17													7
18													
19													
20													
21													
22													
23													
24													
25													
26													
27													
28													
29													
30													8

▨ = If CANTILEVER SIGN configuration (see Cantilever Sign Details) falls in this region, use next larger post size than that indicated.

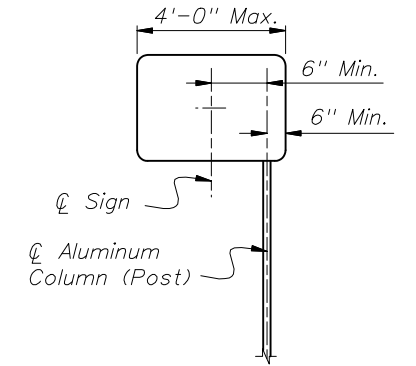

CANTILEVER SIGN

NOTE:
All cantilever sign installations shall comply with Standard Index 17302.

POST AND FOUNDATION TABLE						
Foundation Alternatives						
Post Size	Driven Post *		Concrete **		Diameter (FT)	Depth (FT)
	Diameter (IN)	Wall (IN)	without Soil Plate	with Soil Plate		
0	2.0	1/8	4.5	2.5	2.0	2.0
1	2.5	1/8	5	3	2.0	2.0
2	3.0	1/8	5	3.5	2.0	2.5
3	3.5	3/16	6	4.5	2.0	3.0
4	4.0	1/4	---	---	2.0	4.0
5	4.5	1/4	---	---	2.0	4.0
6	5.0	1/4	---	---	2.0	4.5
7	6.0	1/4	---	---	2.0	5.0
8	8.0	5/16	---	---	2.0	5.5

* INSTALLING FRANGIBLE COLUMN SUPPORTS:
Columns (posts) may be installed by driving the columns in accordance with this Index, or as an alternate method, the columns (posts) may be set to the depth indicated in preformed holes backfilled with suitable material tamped in layers not thicker than 6" to provide adequate compaction or filled with flowable fill or bagged concrete.

** See Note 5 on Sheet 1 of 8.

3/16" Ø Bolt Holes (Hole spacing to match U-Bolts) (washers as required)

R Thickness = 1/4"

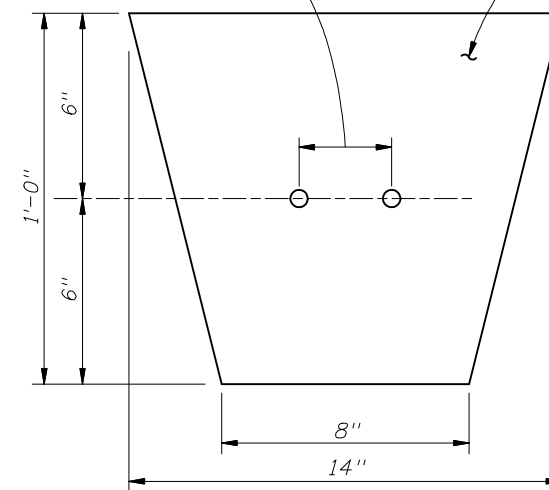

ALUMINUM SOIL PLATE DETAILS

NOTES: 1. Align Soil Plate bottom at 2/3 of foundation depth.
2. Slot up to 1 5/16" long is allowed to accommodate various post sizes.



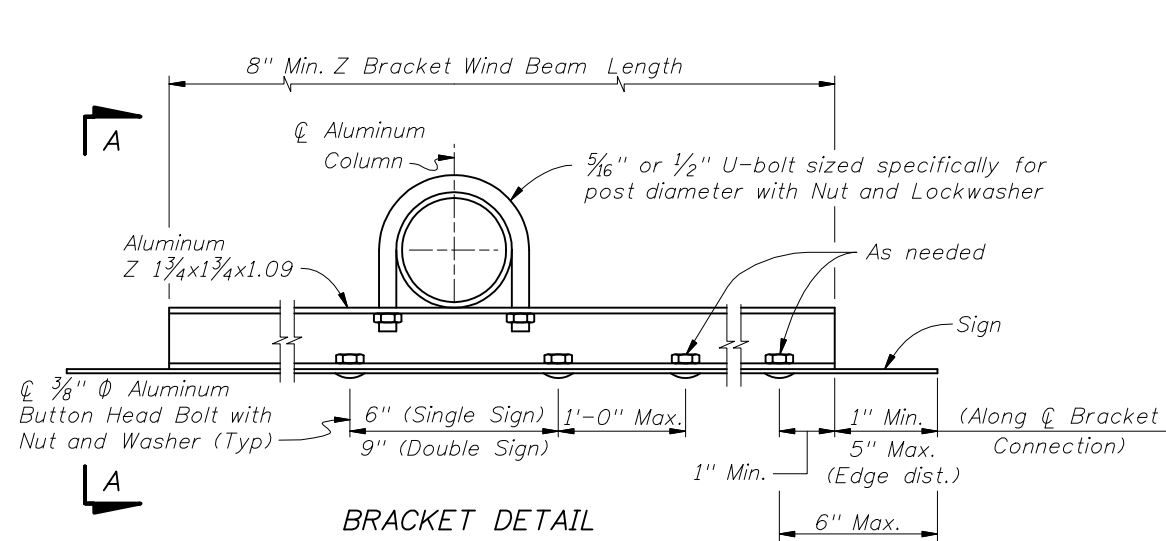

NOTES:

1. $\frac{5}{16}$ " Φ Stainless Steel Hex Head Bolts with Flat Washer under Head and Lockwasher under Nut may be used in lieu of $\frac{3}{8}$ " Φ Aluminum Button Head Bolts.
2. Nylon washers provided by the sheeting supplier shall be used on all ground mounted signs. The washers shall be installed under the sign bolt head to protect the sheeting.
3. Vertical spacing of brackets shall not exceed 2'-6". Use additional brackets, spaced evenly, to maintain maximum spacing.

*For signs with either dimension of sign size greater than 30". (See Sheet No. 6 thru 8 of 8 for sign size)

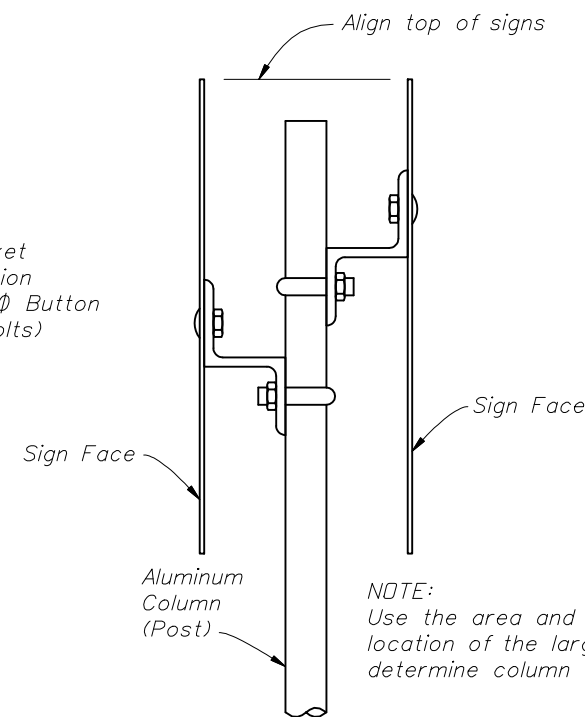
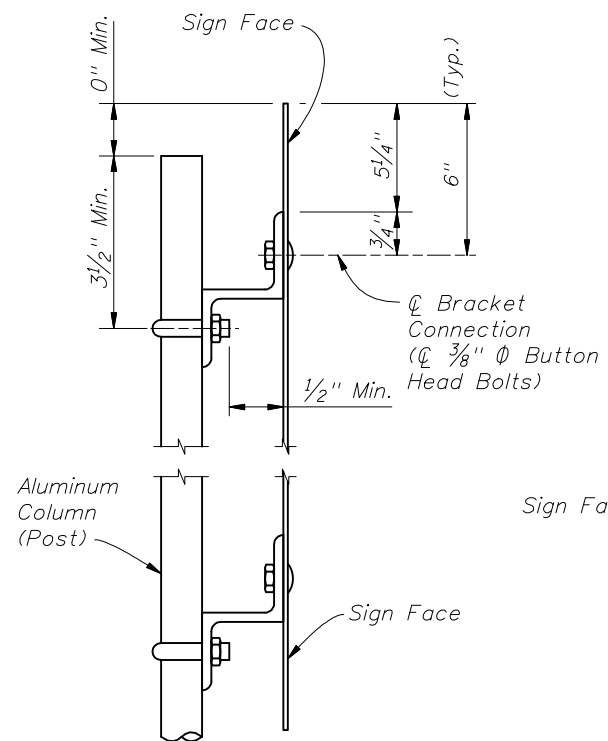

NOTE: Use the area and the centroid location of the largest sign to determine column (post) size.

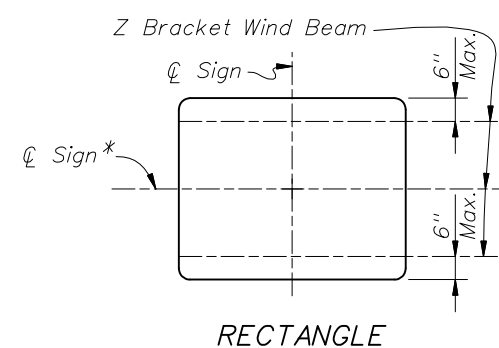
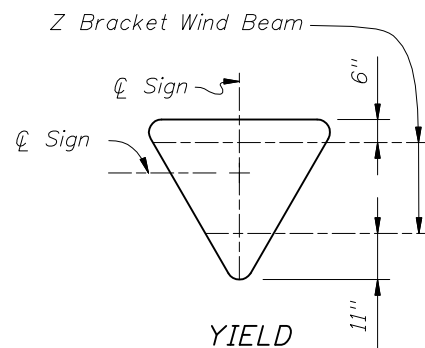
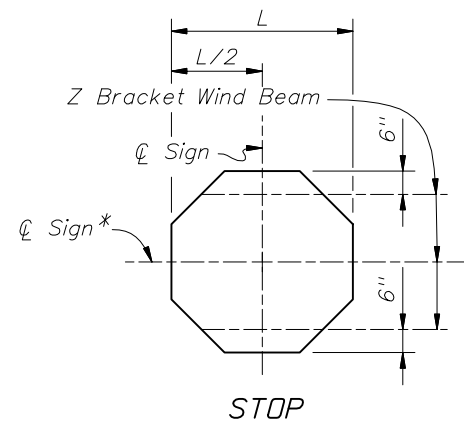
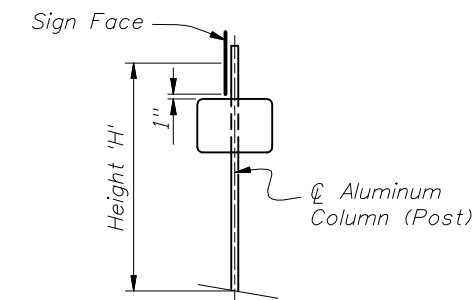

(Use only one Wind Beam at Φ Sign for sign height up to 12")

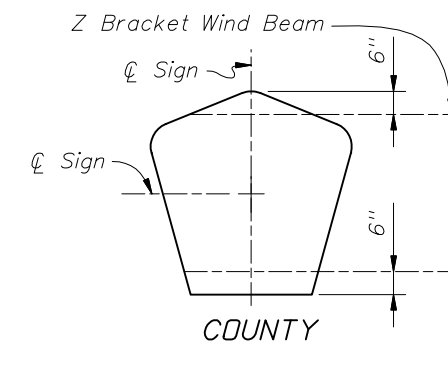
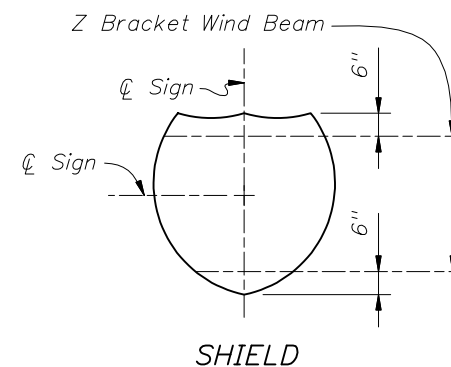
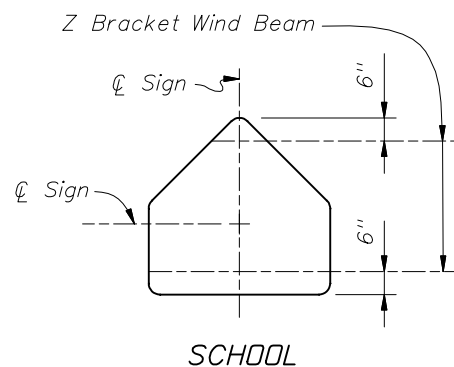
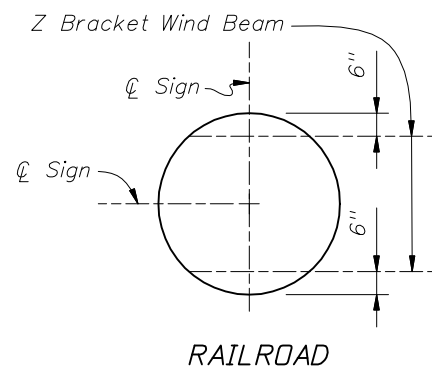
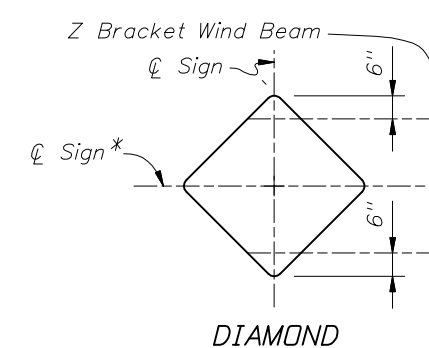

CONNECTION AND WIND BEAM

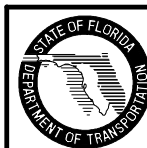

2010 FDOT Design Standards

SINGLE COLUMN GROUND SIGNS

Last Revision	Sheet No.
01/01/09	4 of 8
Index No.	
11860	

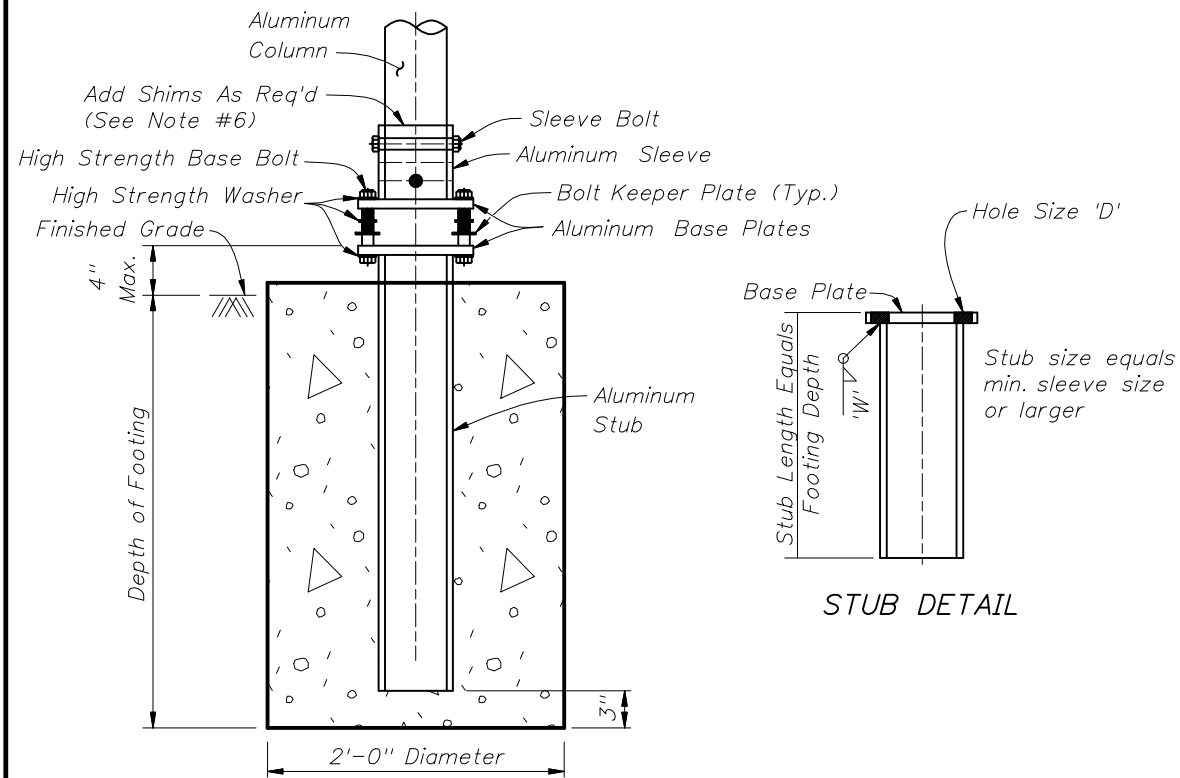

SLIP BASE AND FOOTING DETAIL
(non-frangible post)

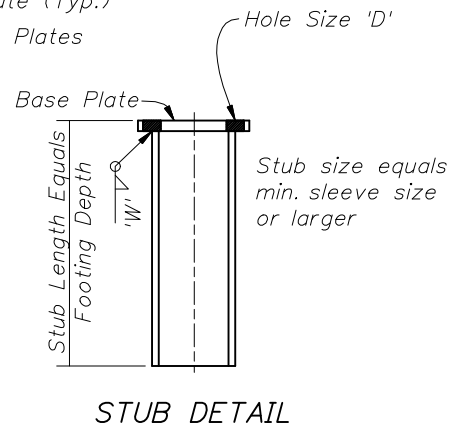

STUB DETAIL

SLIP BASE NOTES:

1. Use sleeves with an inside diameter (I.D.) no more than $\frac{1}{16}$ " larger than the outside diameter (O.D.) of the column.
2. Sleeve Bolts: ASTM A-307, $\frac{1}{2}$ " Φ galvanized steel bolt (with lock nuts) or Alloy 2024-T4 or 6061-T6 (ASTM B-211).
3. Base bolts, Nuts, and Washers: high strength ASTM A-325 with ASTM B633 SC3, Type II electroplated zinc coating.
4. Base plates may have either single or double beveled slots.
5. An alternate cast base plate of aluminum alloy 356 and T6 temper in lieu of the fabricated base plate may be submitted for approval. If a cast base plate is used, the stub will be the same size as the column and will be bolted to the casting.
6. Assemble the slip base connection in the following manner:
 - a. Connect column to sleeve using two $\frac{1}{2}$ " Φ machine bolts.
 - b. Assemble top base plate to stub base plate using high strength bolts with three hardened washers per bolt. One of the three washers per bolt and two bolt keeper plates go between the base plates.
 - c. Use shim stock as required to plumb the column.
 - d. Tighten all bolts to the maximum possible with a 12" to 15" wrench. (This will bed the washers and shims and clear the bolt threads.)
 - e. Loosen each bolt one turn and using a calibrated wrench retighten to the prescribed torque (see table) under the supervision of the Project Engineer.
 - f. Burr threads at junction with nut using a center punch to prevent nut loosening.
7. Use galvanized steel shims to obtain a tight fit between the column face and the sleeve. Place shims in all quadrants between the $\frac{1}{2}$ " Φ sleeve bolts. Use shims that are 1" shorter than the height of the sleeve.
8. Both fabricated and cast base assemblies were impact tested by the Texas Transportation Institute, College Station, TX on February 10, 2003, and both alternate assemblies were determined to be compliant with the performance recommendations of the National Cooperative Highway Research Program (NCHRP) report 350.

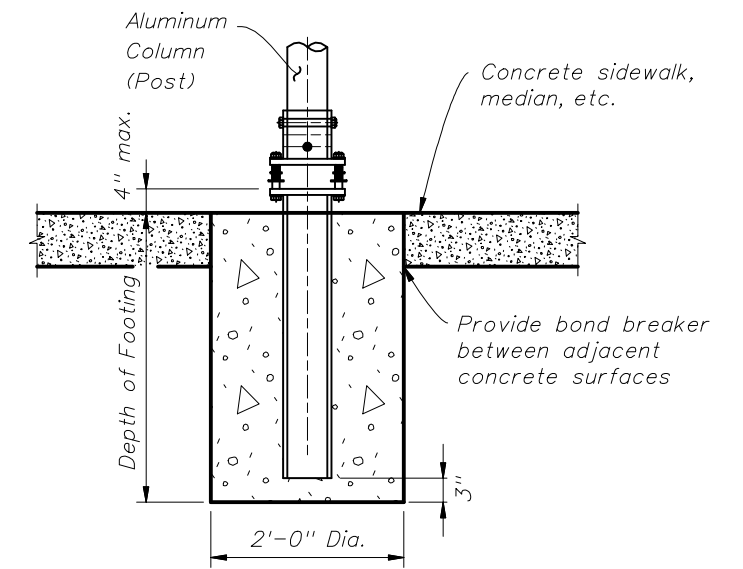

SLIP BASE AND FOOTING DETAIL IN CONCRETE
(non-frangible post in crossovers, medians, & sidewalks)

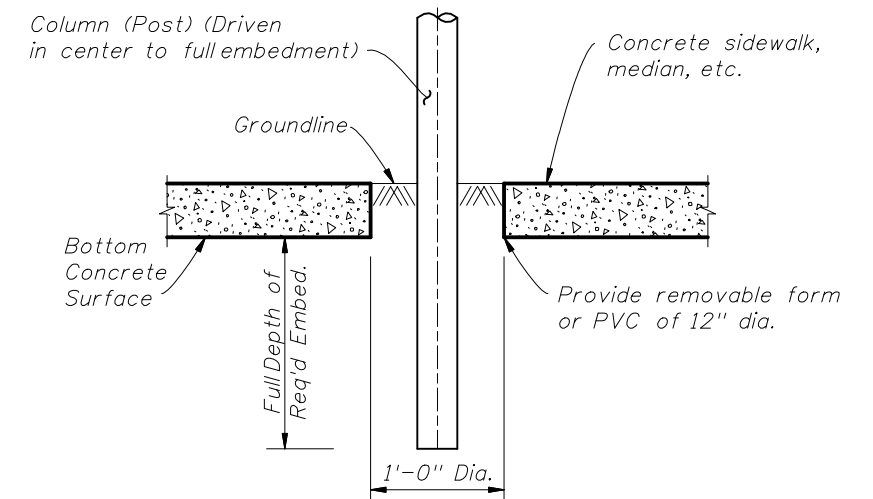

DRIVEN POST DETAIL IN CONCRETE
(frangible post in crossovers, medians, & sidewalks)

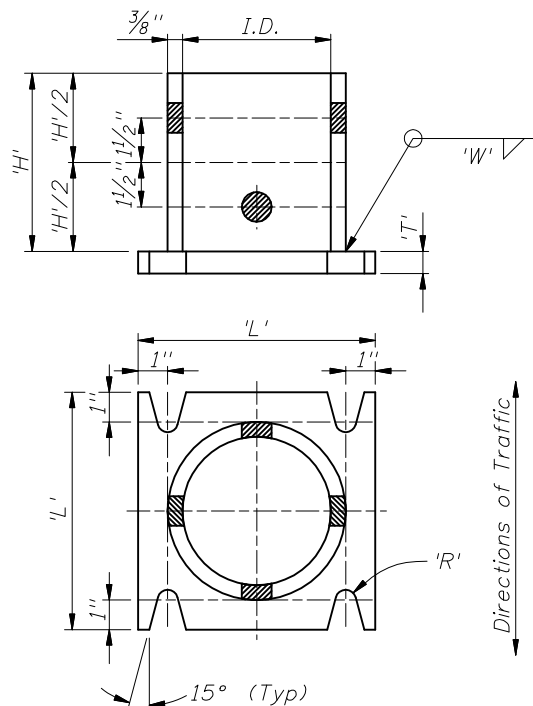

ALUMINUM SLEEVE & BASE PLATE DETAILS
(DOUBLE BEVELED SLOTS)

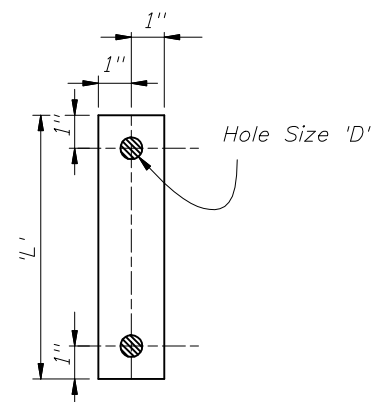

0.0149" Thick Alum. Strip - 2 Req'd Per Base
BOLT KEEPER PLATE DETAIL

SLIP BASE DETAILS

Column Size	Sleeve I.D. (Max)	Sleeve Height 'H'	Weld 'W'	Base Plate		Radius 'R'	Base Bolt		Base Plate Torque		Hole Size 'D'
				'L'	'T'		Size	Length	Ft-lbs	In-lbs	
4 x 1/4	4 1/16	6	5/8	8	3/4	1 1/32	5/8	3	29	345	1 1/16
4 1/2 x 1/4	4 9/16	6	5/8	8	7/8	1 1/32	5/8	3 1/4	29	345	1 1/16
5 x 1/4	5 1/16	7	5/8	8	7/8	1 1/32	5/8	3 1/4	29	345	1 1/16
6 x 1/4	6 1/16	8	1 1/16	9	1	1 3/32	3/4	3 1/2	46	554	1 3/16

Note: Unless notes otherwise, all dimensions are in inches.

BASE AND FOUNDATION DETAILS



































2010 FDOT Design Standards















SINGLE COLUMN GROUND SIGNS

Last Revision 01/01/09
Sheet No. 5 of 8



Index No. 11860





	Size	Area	Total Area	Centroid
 	36x12	3.00 SF	6.31 SF	1.75 Ft.
	24x24	3.31 SF		
 	36x12	3.00 SF	8.18 SF	1.92 Ft.
	30x30	5.18 SF		
 	36x12	3.00 SF	10.46 SF	2.10 Ft.
	36x36	7.46 SF		
 	36x12	3.00 SF	16.25 SF	2.48 Ft.
	48x48	13.25 SF		
 	24x24	3.31 SF	6.31 SF	1.71 Ft.
	24x18	3.00 SF		
 	30x30	5.18 SF	10.18 SF	2.19 Ft.
	30x24	5.00 SF		
 	36x36	7.46 SF	12.46 SF	2.55 Ft.
	30x24	5.00 SF		
  	36x12	3.00 SF	13.18 SF	2.87 Ft.
	30x30	5.18 SF		
	30x24	5.00 SF		

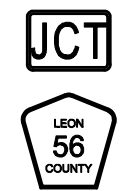
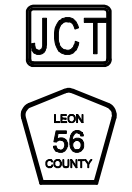
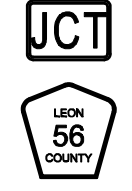

	Size	Area	Total Area	Centroid
  	36x12	3.00 SF	15.46 SF	3.15 Ft.
	36x36	7.46 SF		
	30x24	5.00 SF		
 	21x15	2.19 SF	6.19 SF	1.60 Ft.
	24x24	4.00 SF		
	21x15	2.19 SF		
 	21x15	2.19 SF	7.19 SF	1.52 Ft.
	30x24	5.00 SF		
 	24x12	2.00 SF	6.00 SF	1.53 Ft.
	24x24	4.00 SF		
 	24x12	2.00 SF	7.00 SF	1.45 Ft.
	30x24	5.00 SF		
 	30x15	3.13 SF	8.13 SF	1.66 Ft.
	30x24	5.00 SF		
 	24x24	4.00 SF	6.19 SF	1.73 Ft.
	21x15	2.19 SF		

	Size	Area	Total Area	Centroid
 	30x24	5.00 SF	7.19 SF	1.81 Ft.
	21x15	2.19 SF		
  	24x12	2.00 SF	8.19 SF	2.26 Ft.
	24x24	4.00 SF		
	21x15	2.19 SF		
  	24x12	2.00 SF	9.19 SF	2.27 Ft.
	30x24	5.00 SF		
	21x15	2.19 SF		
  	30x15	3.13 SF	10.32 SF	2.49 Ft.
	30x24	5.00 SF		
	21x15	2.19 SF		
   	24x12	2.00 SF	10.19 SF	2.80 Ft.
	24x12	2.00 SF		
	24x24	4.00 SF		
	21x15	2.19 SF		







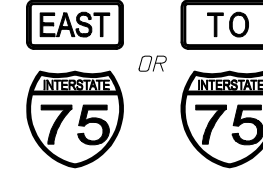
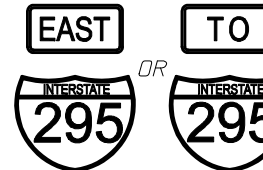
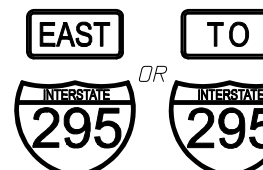
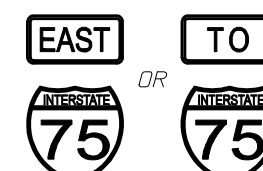



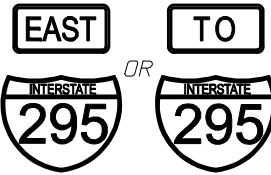
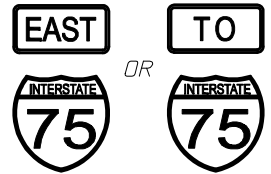

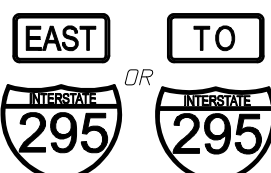
	Size	Area	Total Area	Centroid
	24x12	2.00 SF	11.19 SF	2.76 Ft.
	24x12	2.00 SF		
	30x24	5.00 SF		
	21x15	2.19 SF		
	Size	Area	Total Area	Centroid
	30x15	3.13 SF	13.45 SF	3.16 Ft.
	30x15	3.13 SF		
	30x24	5.00 SF		
	21x15	2.19 SF		
	Size	Area	Total Area	Centroid
	21x15	2.19 SF	3.90 SF	1.57 Ft.
	18x18	1.71 SF		
	Size	Area	Total Area	Centroid
	21x15	2.19 SF	5.22 SF	1.72 Ft.
	24x24	3.03 SF		
	Size	Area	Total Area	Centroid
	21x15	2.19 SF	6.95 SF	1.87 Ft.
	30x30	4.76 SF		

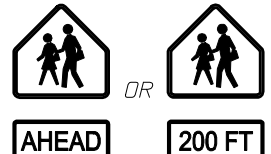
	Size	Area	Total Area	Centroid
	18x18	1.71 SF	3.90 SF	1.26 Ft.
	21x15	2.19 SF		
	Size	Area	Total Area	Centroid
	24x24	3.03 SF	5.22 SF	1.62 Ft.
	21x15	2.19 SF		
	Size	Area	Total Area	Centroid
	30x30	4.76 SF	6.95 SF	1.97 Ft.
	21x15	2.19 SF		
	Size	Area	Total Area	Centroid
	24x12	2.00 SF	9.39 SF	2.87 Ft.
	24x12	2.00 SF		
	24x24	3.20 SF		
	21x15	2.19 SF		
	Size	Area	Total Area	Centroid
	24x12	2.00 SF	10.18 SF	2.84 Ft.
	24x12	2.00 SF		
	30x24	3.99 SF		
	21x15	2.19 SF		

	Size	Area	Total Area	Centroid
	30x15	3.13 SF	12.44 SF	3.26 Ft.
	30x15	3.13 SF		
	30x24	3.99 SF		
	21x15	2.19 SF		
	Size	Area	Total Area	Centroid
	21x15	2.19 SF	5.39 SF	1.75 Ft.
	24x24	3.20 SF		
	Size	Area	Total Area	Centroid
	21x15	2.19 SF	6.18 SF	1.67 Ft.
	30x24	3.99 SF		
	Size	Area	Total Area	Centroid
	24x12	2.00 SF	5.20 SF	1.67 Ft.
	24x24	3.20 SF		
	Size	Area	Total Area	Centroid
	24x12	2.00 SF	5.99 SF	1.60 Ft.
	30x24	3.99 SF		
	Size	Area	Total Area	Centroid
	30x15	3.13 SF	7.12 SF	1.81 Ft.
	30x24	3.99 SF		
	Size	Area	Total Area	Centroid
	30x15	3.13 SF	10.33 SF	2.27 Ft.
	36x36	7.20 SF		

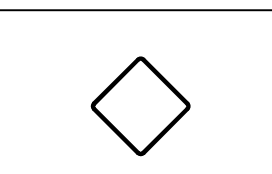
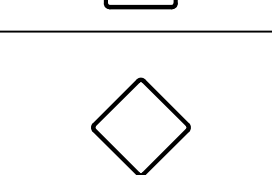

Size	Area	Total Area	Centroid
	30x15	3.13 SF	
		12.12 SF	2.18 Ft.
	45x36	8.99 SF	
Size	Area	Total Area	Centroid
	24x12	2.00 SF	
		7.39 SF	2.30 Ft.
	24x24	3.20 SF	
	21x15	2.19 SF	
Size	Area	Total Area	Centroid
	24x12	2.00 SF	
		8.18 SF	2.31 Ft.
	30x24	3.99 SF	
	21x15	2.19 SF	
Size	Area	Total Area	Centroid
	30x15	3.13 SF	
		9.31 SF	2.55 Ft.
	30x24	3.99 SF	
	21x15	2.19 SF	
Size	Area	Total Area	Centroid
	30x30	4.69 SF	
		6.69 SF	1.61 Ft.
	24x12	2.00 SF	
Size	Area	Total Area	Centroid
	30x30	4.69 SF	
		8.44 SF	1.77 Ft.
	30x18	3.75 SF	
Size	Area	Total Area	Centroid
	36x36	6.75 SF	
		10.50 SF	2.06 Ft.
	30x18	3.75 SF	

Size	Area	Total Area	Centroid
	30X30	4.69 SF	
		6.69 SF	1.61 Ft.
	24X12	2.00 SF	
Size	Area	Total Area	Centroid
	30X30	4.69 SF	
		8.44 SF	1.77 Ft.
	30X18	3.75 SF	
Size	Area	Total Area	Centroid
	36X36	6.75 SF	
		10.50 SF	2.06 Ft.
	30X18	3.75 SF	
Size	Area	Total Area	Centroid
	30X30	6.25 SF	
		8.25 SF	2.28 Ft.
	24X12	2.00 SF	
Size	Area	Total Area	Centroid
	36X36	9.00 SF	
		12.75 SF	2.84 Ft.
	30X18	3.75 SF	
Size	Area	Total Area	Centroid
	30X30	6.25 SF	
		10.25 SF	2.74 Ft.
	24X24	4.00 SF	
Size	Area	Total Area	Centroid
	36X36	9.00 SF	
		15.25 SF	3.29 Ft.
	30X30	6.25 SF	

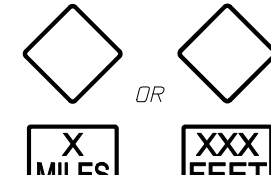
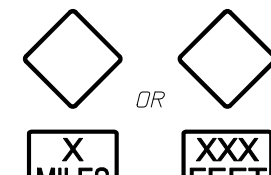
Size	Area	Total Area	Centroid
	30X30	6.25 SF	
		9.25 SF	2.51 Ft.
	24X18	3.00 SF	
Size	Area	Total Area	Centroid
	36X36	9.00 SF	
		14.00 SF	3.06 Ft.
	30X24	5.00 SF	



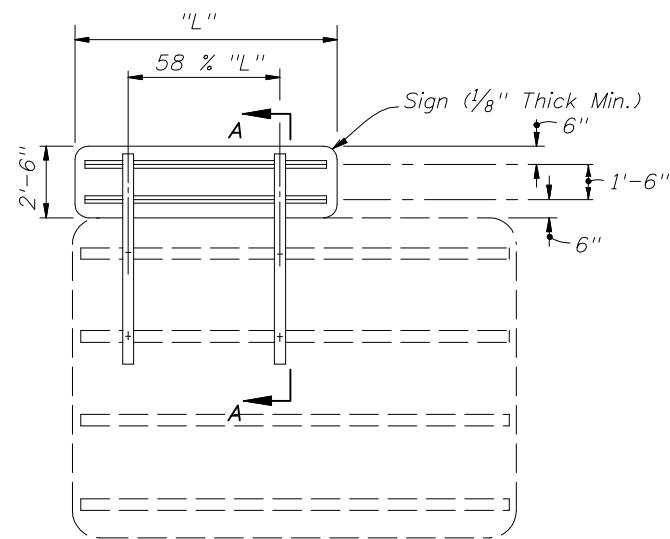

NOTE: Exit numbering panel shall be located to the right side for right exit and to the left for left exit.

Mounting of Exit Numbering Panels To Highway Signs

ELEVATION

Bolt Sign to Zee Using $\frac{1}{4}$ " ϕ Aluminum Flat Head Bolts, Nuts and Lock Washers (Typ.)
12" Max Spacing

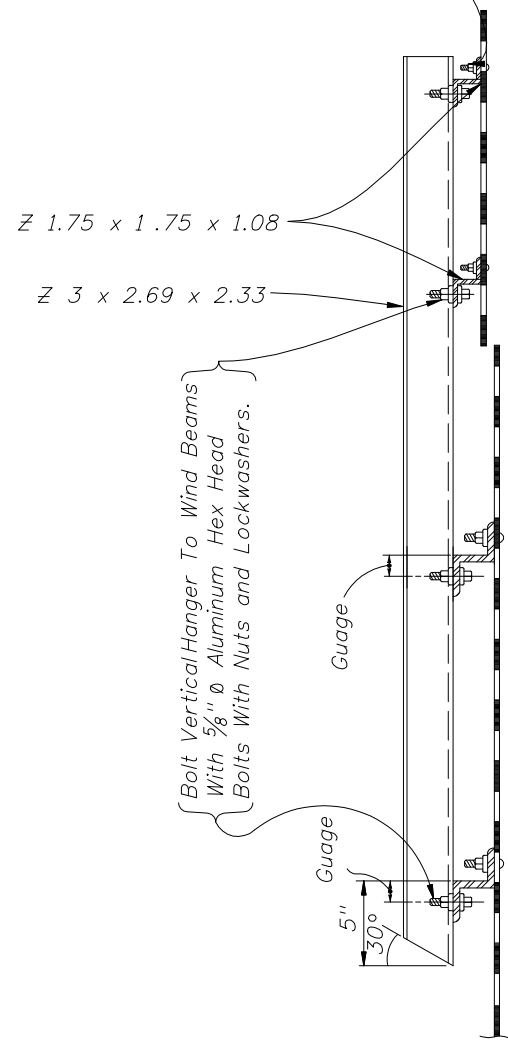

Bolt Vertical Hanger To Wind Beams With $\frac{5}{8}$ " ϕ Aluminum Hex Head Bolts With Nuts and Lockwashers.

SECTION AA

GENERAL NOTES

DESIGN SPECIFICATION: Design according to FDOT Structures Manual (current edition) Standard Specifications for Structural Supports for Highway Signs, Luminaires and Traffic Signals, AASHTO 2001.
SHEETS AND PLATES: Material used shall meet the requirements of Aluminum Association Alloy 6061-T6 and ASTM B209.
MATERIALS: All aluminum materials shall meet the requirements of the Aluminum Association Alloy 6061-T6 and also the following ASTM specifications for the following: Sheets and plates B209; extruded shapes B221 and standard structural shapes B308.
ALUMINUM BOLTS, NUTS & LOCK WASHERS: Aluminum bolts shall meet the requirements of the Aluminum Association Alloy 2024-T4 (ASTM F468). The bolts shall have an anodic coating of at least .0002" thick and be chromate sealed. Lock washers shall meet the requirement of Aluminum Association Alloy 7075-T6 (ASTM B221). Nuts shall meet the requirement of Aluminum Association Alloy 6262-T9 (ASTM F467) or 6061-T6.
SIGN FACE: All sign face corners shall be rounded. See sign layout sheet for dimension "L" and sign face details. For mounting details refer to Index No. 11300.



2010 FDOT Design Standards

MOUNTING EXIT NUMBERING PANELS TO HIGHWAY SIGNS

Last Revision	Sheet No.
07/01/09	1 of 1
Index No.	
13417	

CASE I

For Use On Freeway And Expressway Systems For Signs On Mainline.

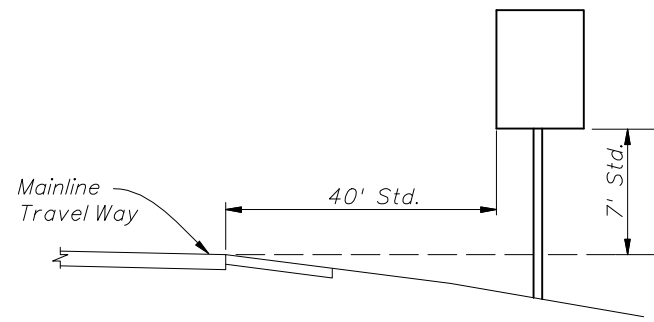

For Median Installation:
If Median Width Does Not Allow Std. Offset From Both Roadways, Center Sign In Median.

CASE II

For Use In All Rural Roads And On Freeway And Expressway Ramps.

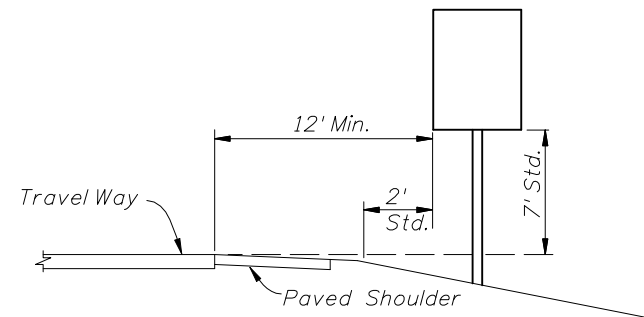

14' Horizontal Clearance Standard On All Freeway And Expressway Ramps.

CASE III

For Use On All Roads With Signs Mounted Behind Sidewalk.

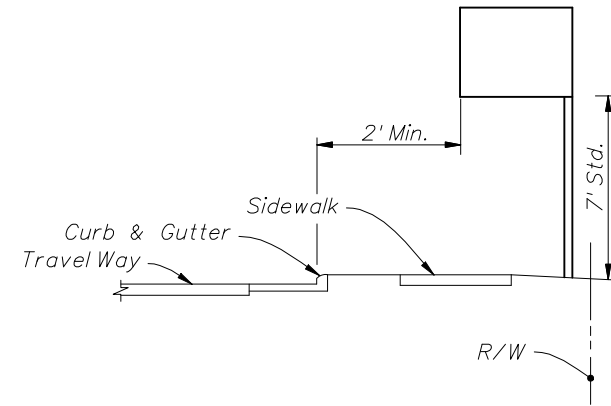

GENERAL NOTES:

1. The typical sections shown hereon serve as a guide for locating the traffic signs required under various roadside conditions. For size and details of sign construction and footing, refer to the appropriate standard index drawing for roadside sign.
2. It shall be the CONTRACTORS responsibility to verify the length of sign supports in the field prior to fabrication.
3. Ground signs shall be installed at an angle of 1 to 4 degrees away from the traffic flow (see illustration). Shoulder mounted signs shall be rotated counterclockwise and median mounted signs rotated clockwise. Signs on curves shall be mounted as noted above from the perpendicular to the motorist line of sight.

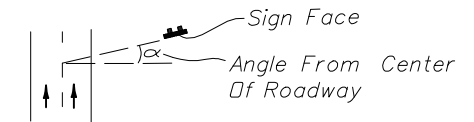

CASE IV (MERGE SIGN)

For Use On All Rural, Freeway And Expressway Systems.

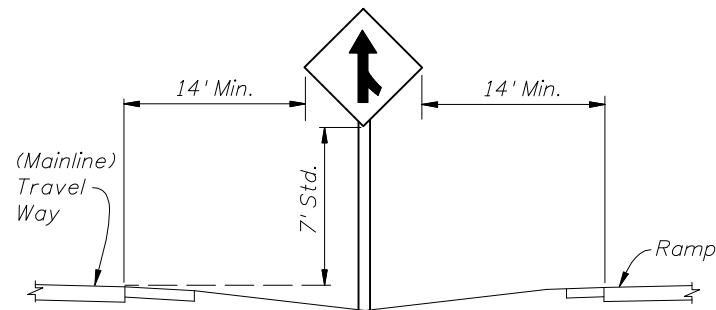

CASE V

For Use In Business Or Residential Areas Only.

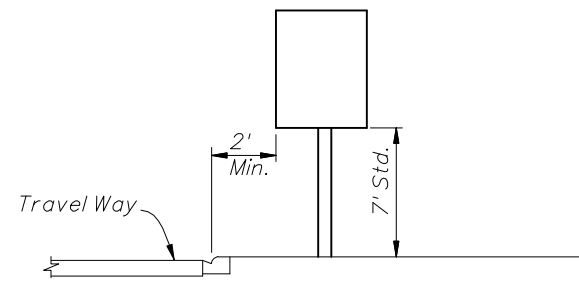

CASE VI

For Use On All Roadways With Signs Behind Guardrail.

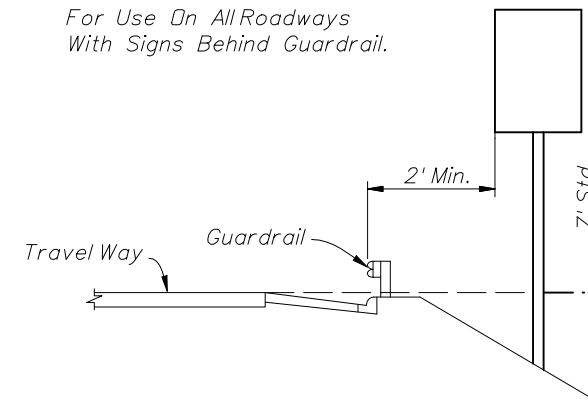

4. The setback for stop and yield signs may be reduced to 3' minimum from the driving lane if required for visibility in business or residential sections with no curb and speeds of 30 MPH or less.
5. The mounting heights are measured from the bottom of the sign panel to a horizontal line extended from the edge of the driving lane. If the standard heights cannot be met, the minimum heights are as follows:

Expressway & Freeway Systems	7'
Other Roadway Systems	
Rural	5'
Urban (including residential with parking and /or pedestrian activity)	7'

If a secondary sign is mounted below the major sign, the major sign shall be at least 8' and the secondary sign at least 5' for expressway & freeway systems and for other systems the height to the secondary sign shall be at least 5' for rural and 7' for urban sections.

CASE VII (REST AREA & EXIT GORE SIGNS)

For Use On All Freeway And Expressway Systems

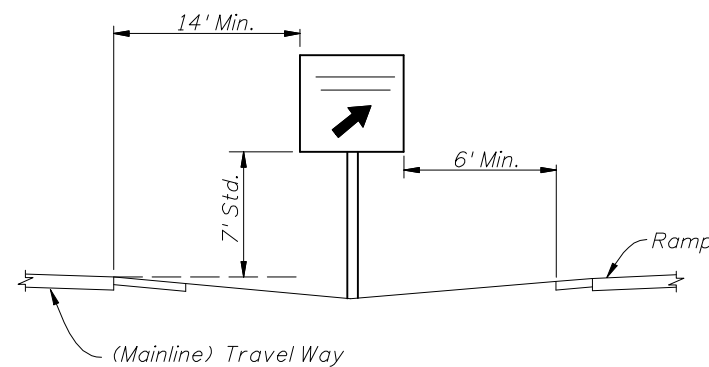

CASE VIII

Sign On Island or Curbed Median

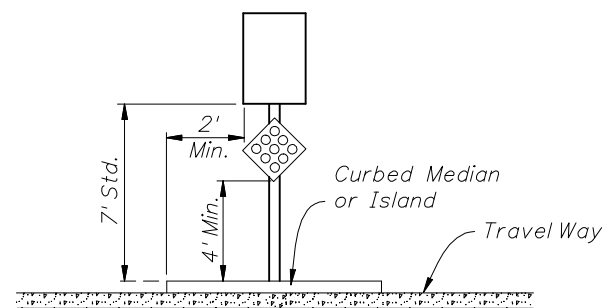

Center Sign Column On Island

CASE IX (MILE POST MARKER)

For More Information Refer To Part 2D-46 Of The Manual On Uniform Traffic Control Devices

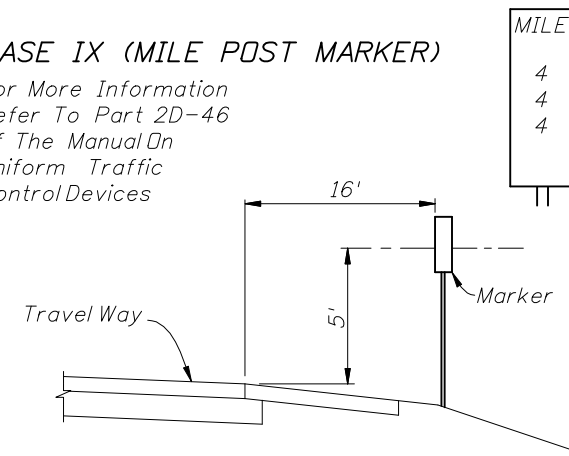

6. Sign supports should never be placed in the bottom of ditches where erosion might affect the proper operation of the breakaway feature.
7. Sign supports shall not reduce the accessible route /continuous passage to less than 4' min. clear width as required by the Americans with Disabilities Act (ADA) Accessibility Guidelines.



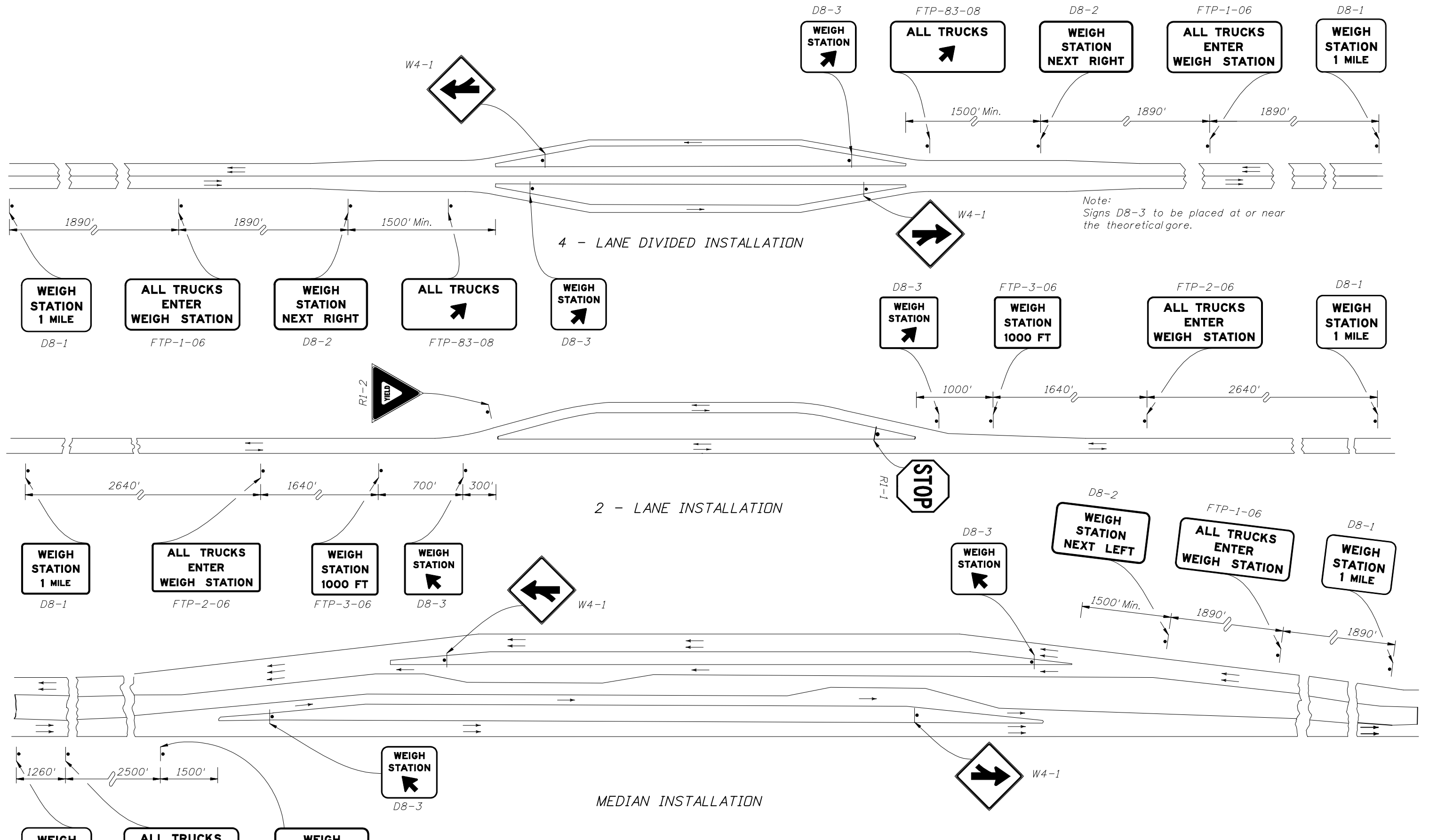

WEIGH STATION SIGNING

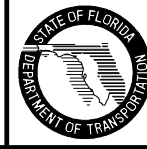

2010 FDOT Design Standards

TYPICAL SIGNING FOR TRUCK WEIGH AND INSPECTION STATIONS

Last Revision 07/01/09 Sheet No. 1 of 2

Index No. 17328

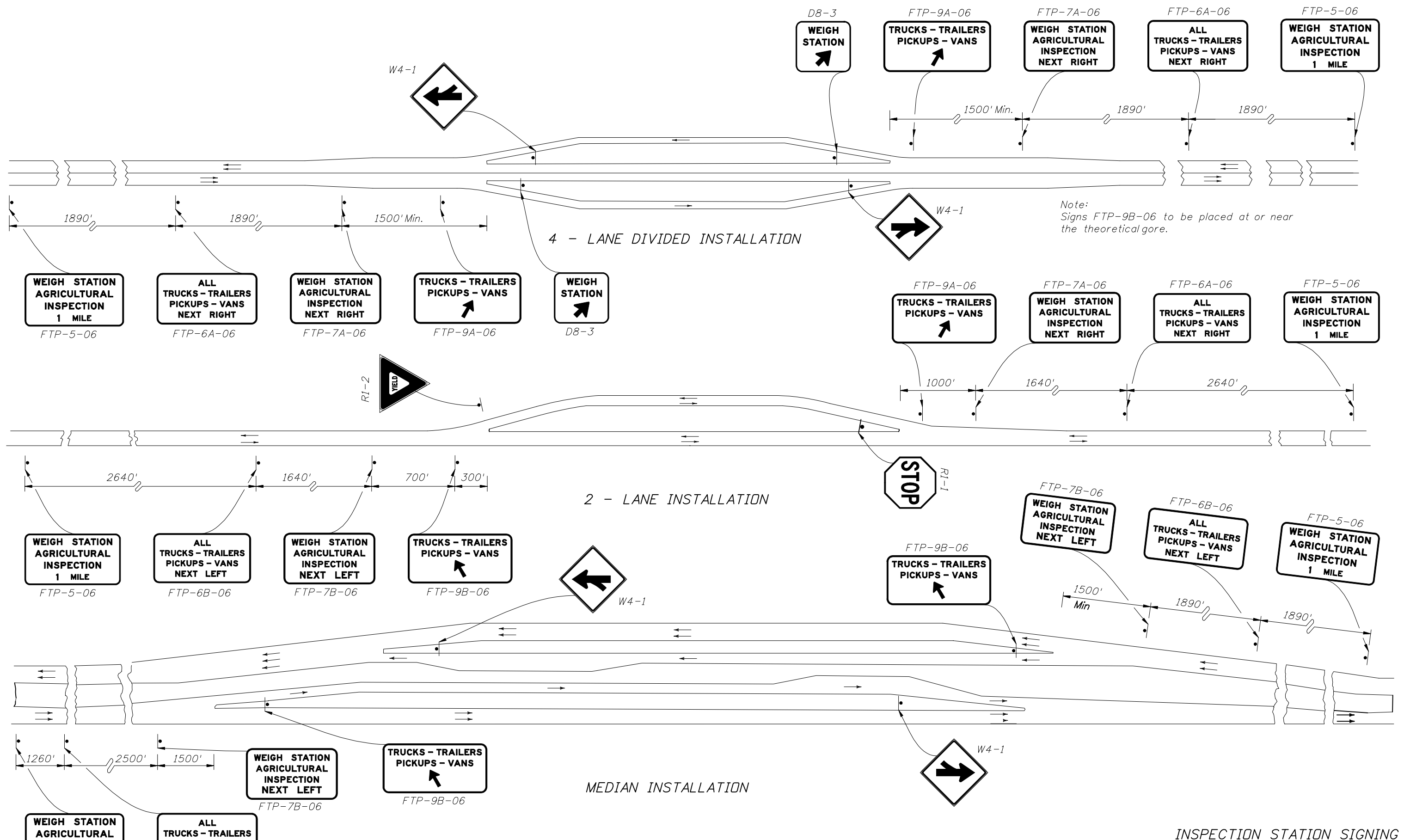

INSPECTION STATION SIGNING



2010 FDOT Design Standards

TYPICAL SIGNING FOR TRUCK WEIGH AND INSPECTION STATIONS

Last Revision	Sheet No.
07/01/09	2 of 2
Index No.	
17328	

Approach Speed (MPH)	Distance A (FT.)
25 or Less	200
26 To 35	250
36 To 45	300
46 To 55	325

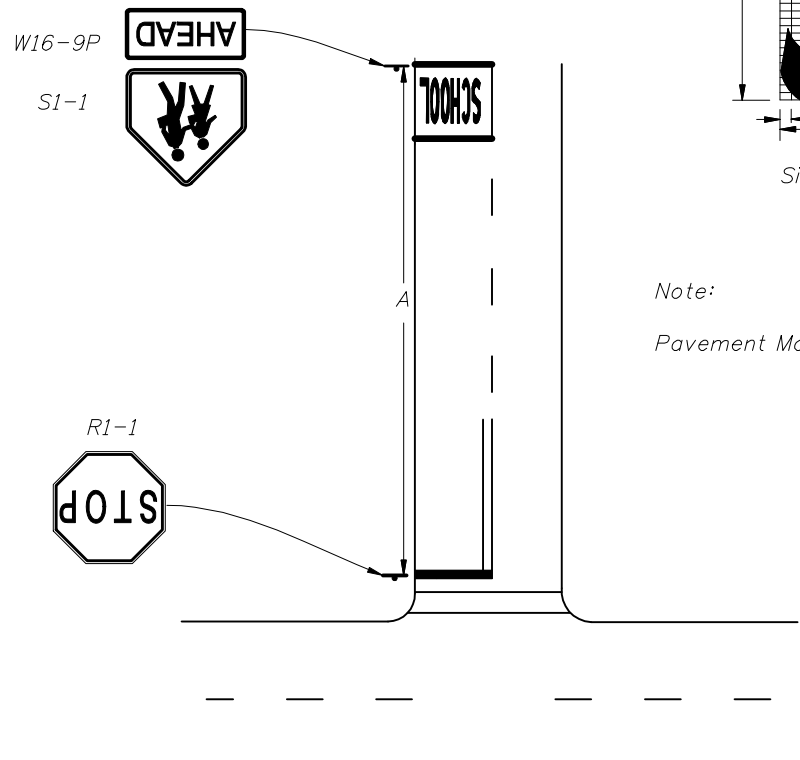
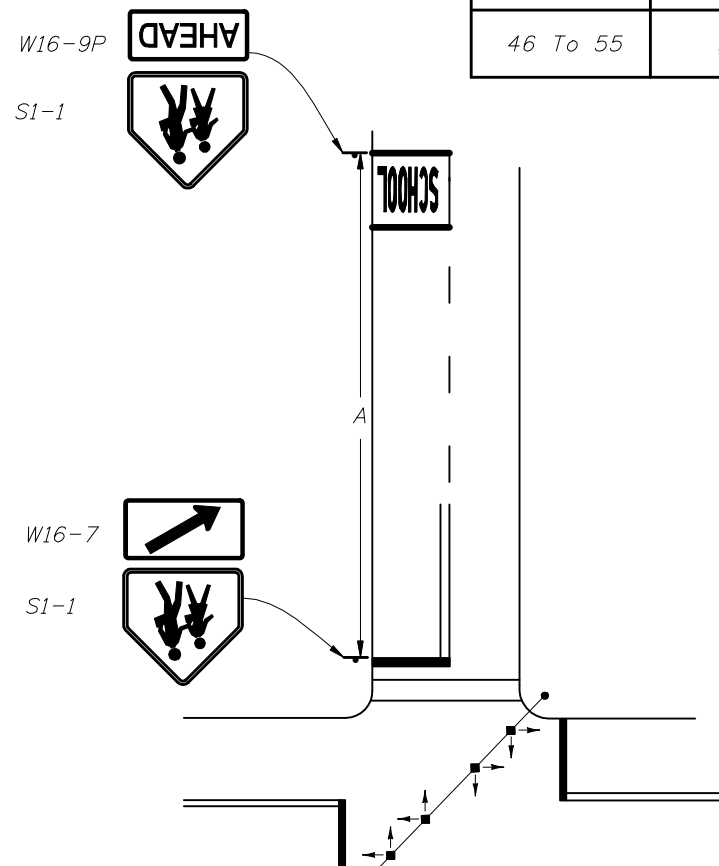

"No Right Turn On Red" Signs may be erected as deemed necessary by the local traffic engineers.

1. TRAFFIC CONTROL DEVICES FOR A SCHOOL CROSSWALK AT A SIGNALIZED INTERSECTION

2. TRAFFIC CONTROL DEVICES FOR A SCHOOL CROSSWALK AT A STOP CONTROLLED INTERSECTION

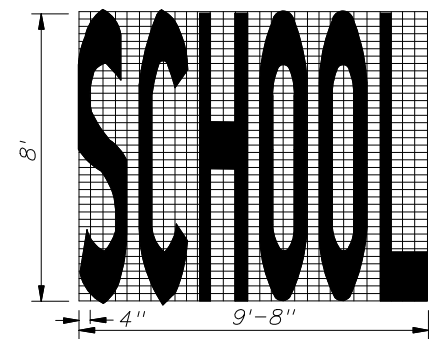

Single-Lane Pavement Marking
33 s.f.

Note:
Pavement Marking Should Not Extend Into Opposing Lane.

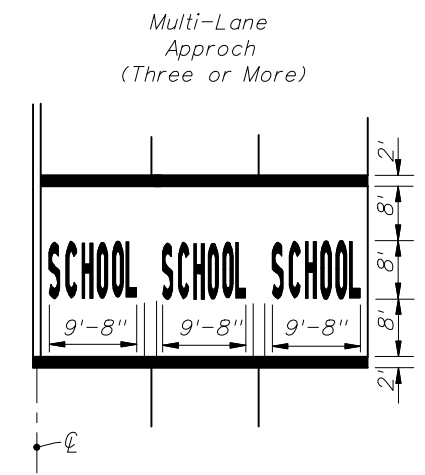
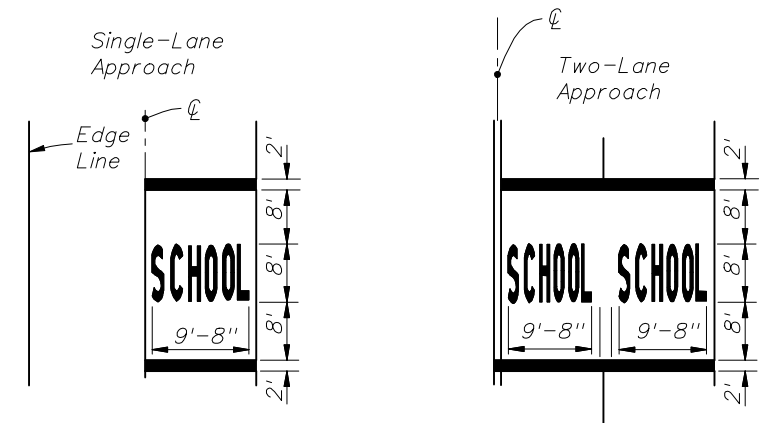

PAVEMENT MARKINGS

Notes:
Signs shall be erected in accordance with index No. 17302.
When computing pavement message quantities do not include transverse lines.
School crosswalk widths at intersections shall be 6' minimum 10' standard without public sidewalk curb ramps 10' minimum with public sidewalk curb ramps.
For additional marking information, see Index 17346, Sheet 2.

Note:
Special speed restrictions are not normally applicable to these two cases.



3. TRAFFIC CONTROL DEVICES FOR REDUCED SPEED ZONE AT A SCHOOL CROSSWALK 2 LANES-2 WAY TRAFFIC (40 MPH OR LESS) (MIDBLOCK OR ON THRU STREET AT AN INTERSECTION)

4. TRAFFIC CONTROL DEVICES FOR REDUCED SPEED ZONE AT A SCHOOL CROSSWALK 2 LANES-2 WAY TRAFFIC (45 MPH OR GREATER) (MIDBLOCK OR ON THRU STREET AT AN INTERSECTION)

5. TRAFFIC CONTROL DEVICES FOR A SCHOOL CROSSWALK WITHOUT A SPEED REDUCTION (2 LANE-2 WAY TRAFFIC)

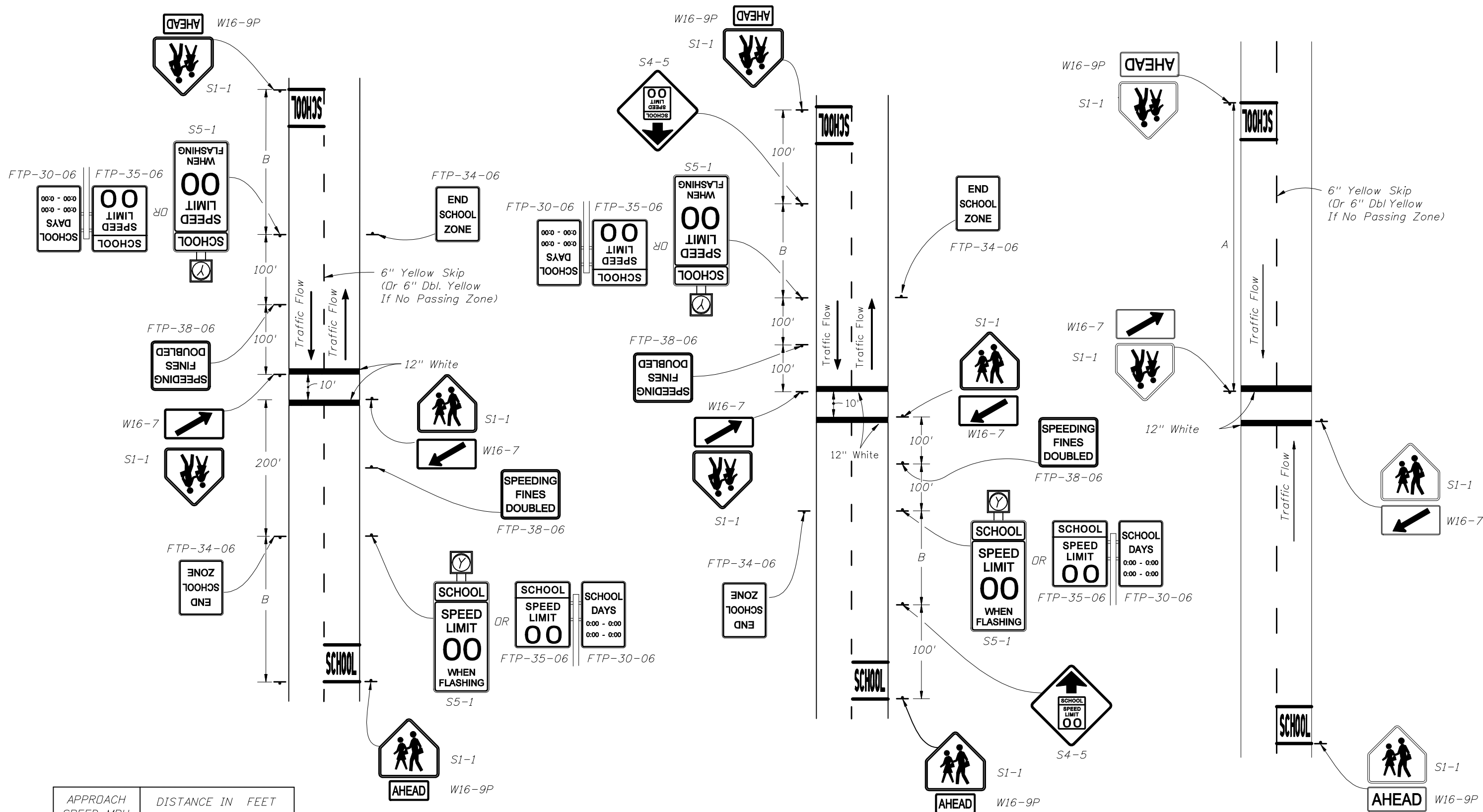

APPROACH SPEED MPH	DISTANCE IN FEET	
	A	B
25 or Less	200'	100' Min.
26 To 35	250'	100' Min.
36 To 45	300'	100'
46 To 55	325'	125'

SCHOOL CROSSWALK
Midblock crosswalks shall be a minimum of 10'.
See Index No. 17346 sheet 2 and 8.



2010 FDOT Design Standards

SCHOOL SIGNS & MARKINGS

Last Revision 07/01/09	Sheet No. 2 of 6
Index No. 17344	

6. TRAFFIC CONTROL DEVICES FOR A REDUCED SPEED ZONE AT A SCHOOL CROSSWALK WITH OVERHEAD FLASHING BEACON SPEED LIMIT SIGNS (4 LANES UNDIVIDED-2 WAY TRAFFIC) (MIDBLOCK OR ON THRU STREET AT AN INTERSECTION)

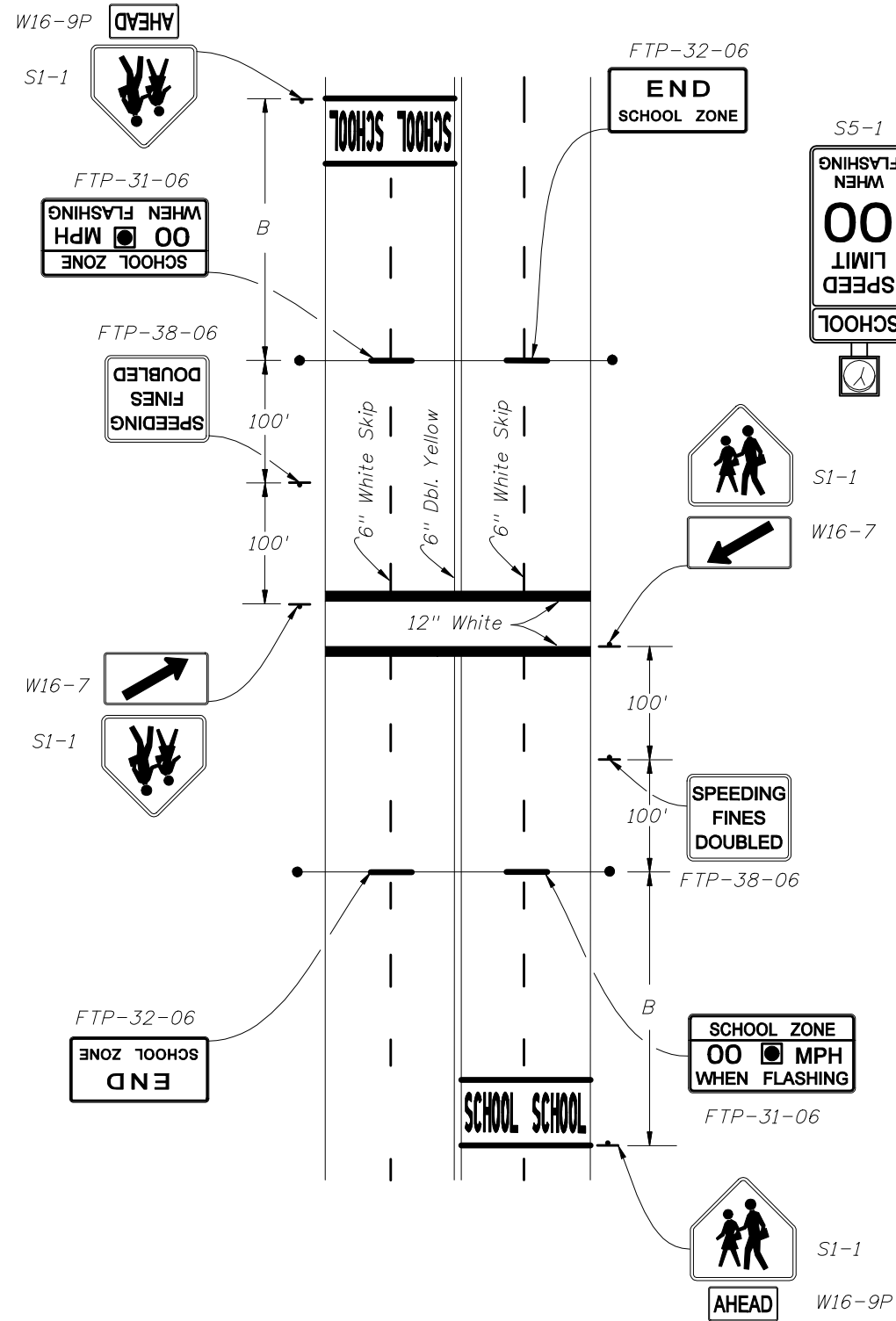

7. TRAFFIC CONTROL DEVICES FOR A REDUCED SPEED ZONE AT A SCHOOL CROSSWALK WITH OVERHEAD OR GROUND MOUNTED FLASHING BEACON SPEED LIMIT SIGNS (4 LANES DIVIDED-2 WAY TRAFFIC)

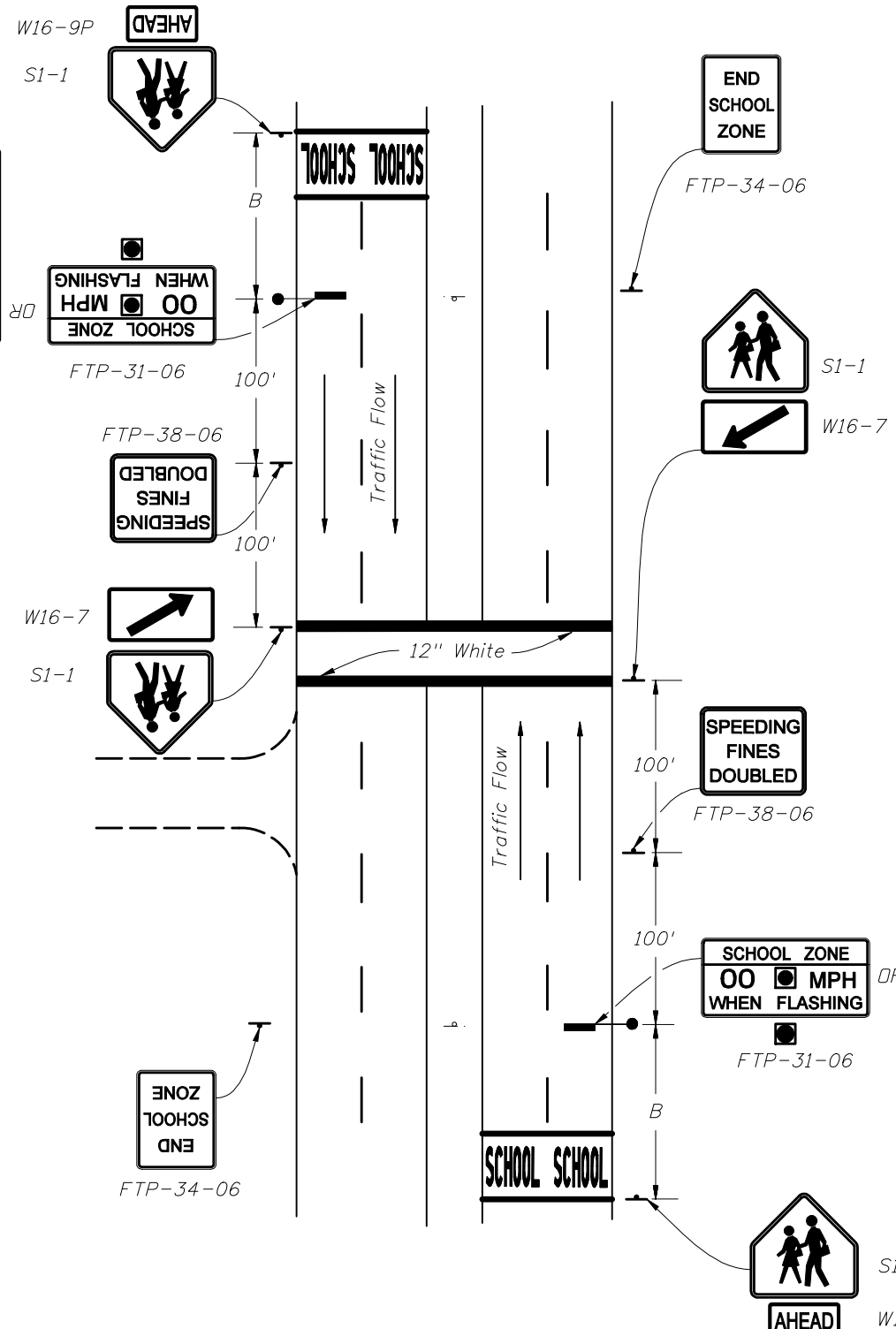

8. TRAFFIC CONTROL DEVICES FOR SIGNALIZED MIDBLOCK SCHOOL CROSSWALK

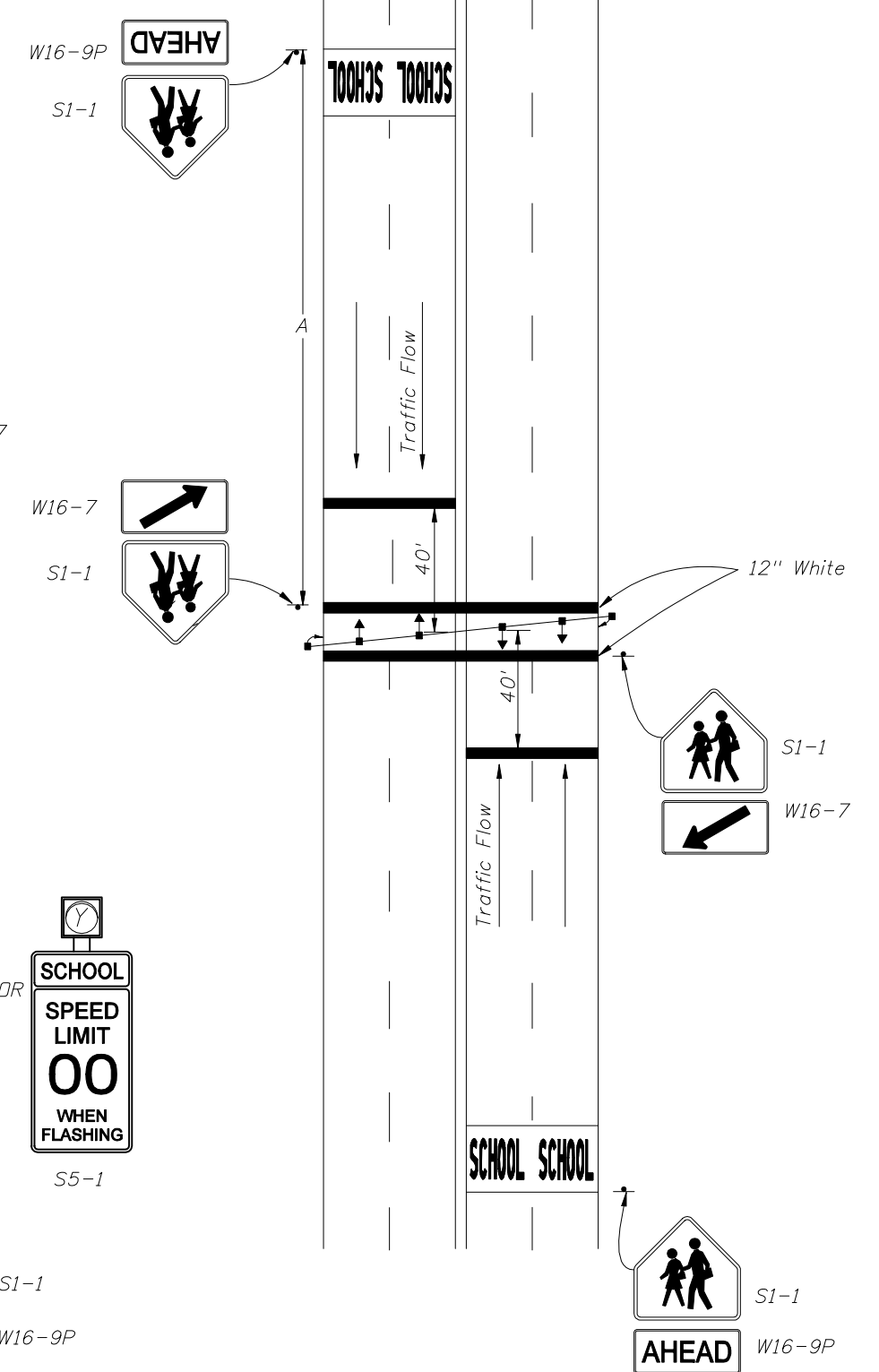

APPROACH SPEED MPH	DISTANCE IN FEET	
	A	B
25 or Less	200'	100' Min.
26 To 35	250'	100' Min.
36 To 45	300'	100'
46 To 55	325'	125'

SCHOOL CROSSWALK
Midblock crosswalk shall be a minimum of 10'.
See Index No. 17346, Sheet 2 and 8.

NOTE- CONDITION 7:
Where engineering judgement determines the overhead structure is not suitable or cannot be installed due to site restrictions, S5-1 with flashing beacons on each side of the road may be substituted for the overhead structure.



2010 FDOT Design Standards

SCHOOL SIGNS & MARKINGS

Last Revision 07/01/09
Sheet No. 3 of 6

Index No. 17344

9. TRAFFIC CONTROL DEVICES AT SCHOOL ENTRANCES WITH LOW VOLUMES OF WALKING STUDENTS

10. TRAFFIC CONTROL DEVICES FOR A TYPICAL SCHOOL ZONE FRONTING THE SCHOOL PROPERTY

11. SCHOOL BUS STOP

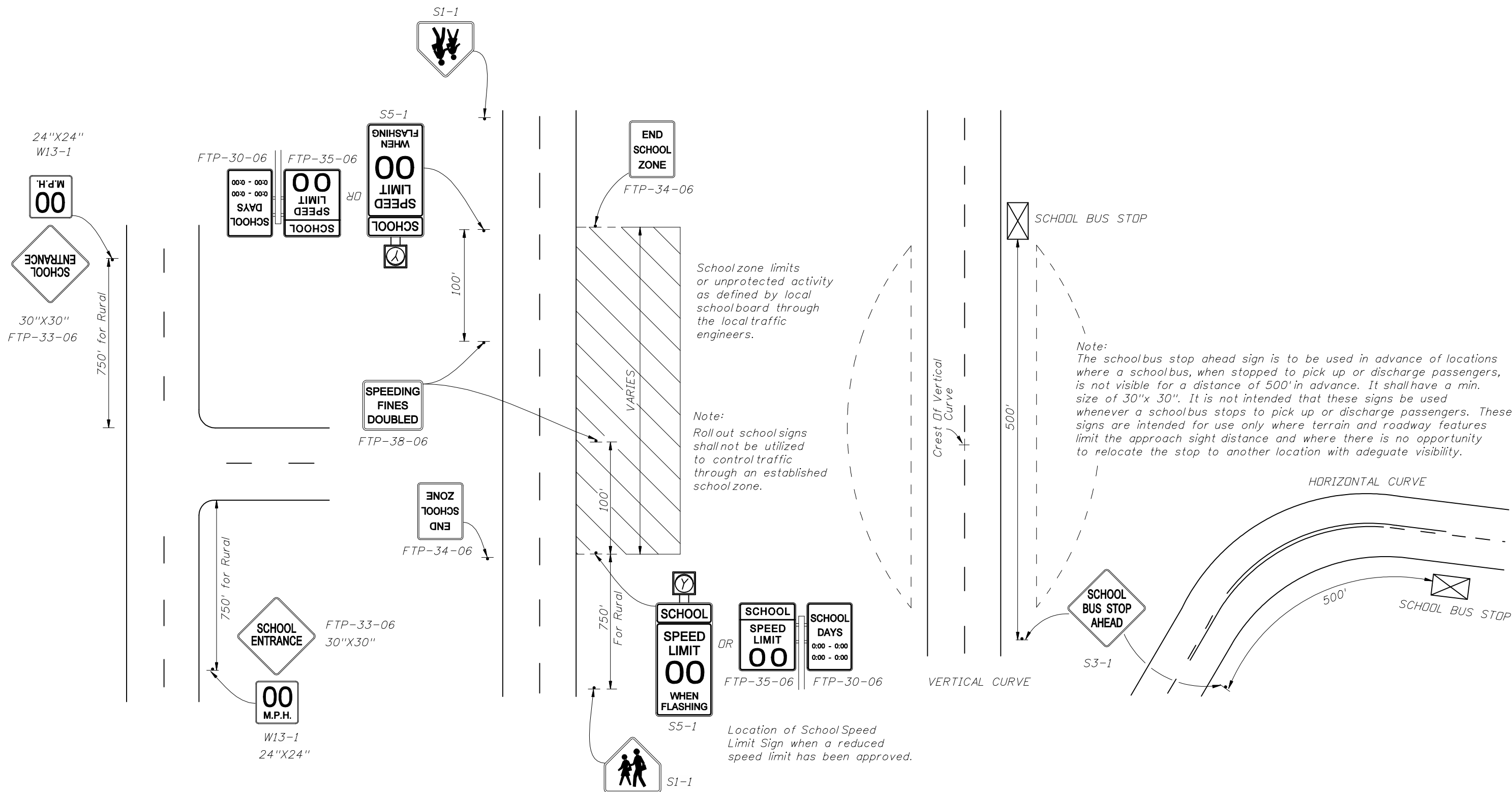

These signs are intended for use only at those few locations where the school entrance is not evident to the motorist, and must be approved in advance by the responsible traffic engineering authority.

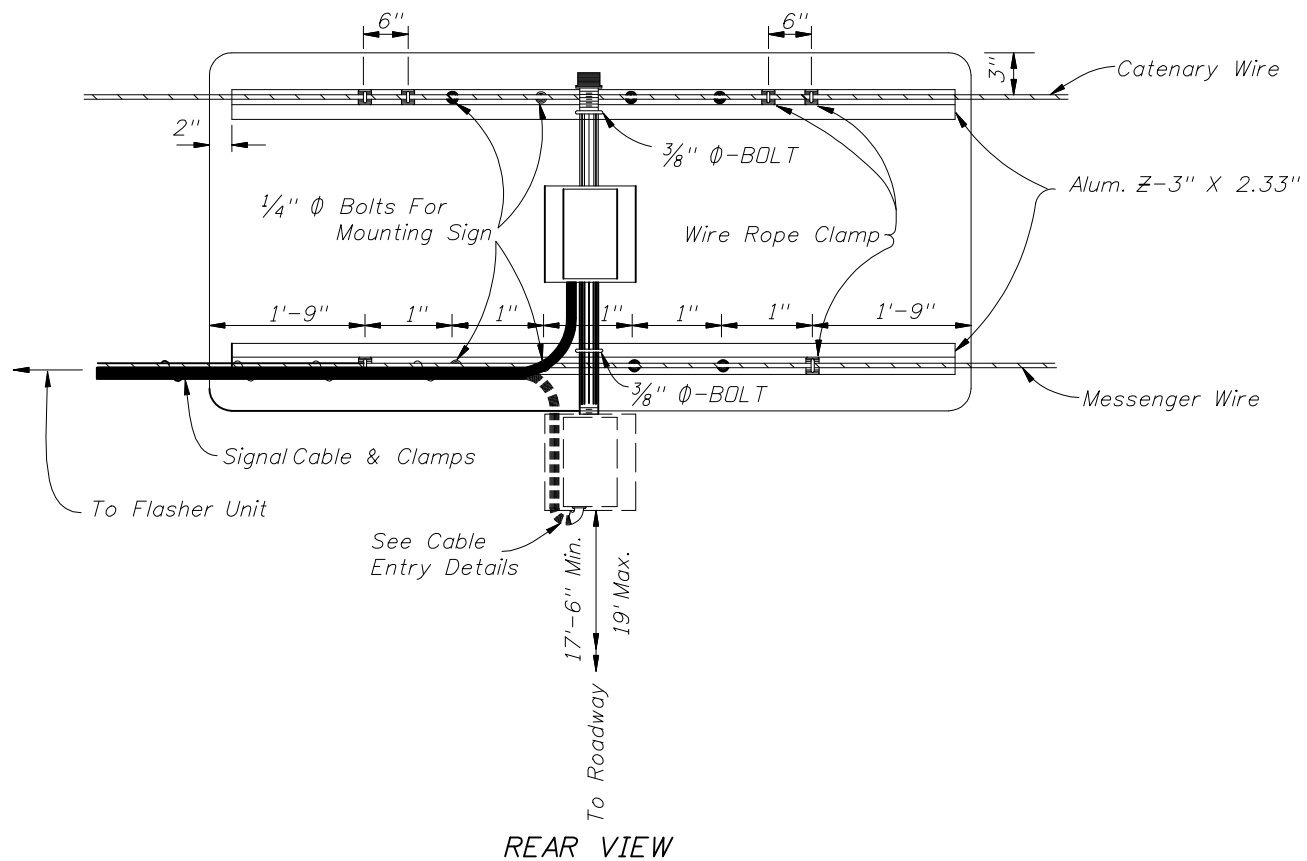

REAR VIEW

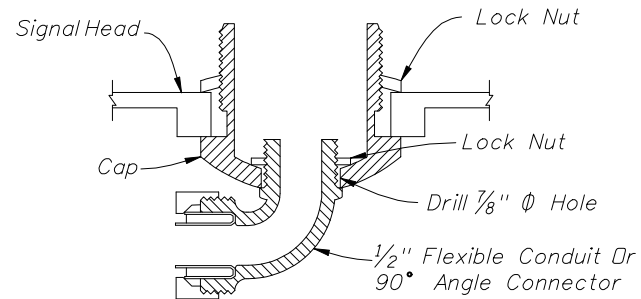

CABLE ENTRY DETAIL

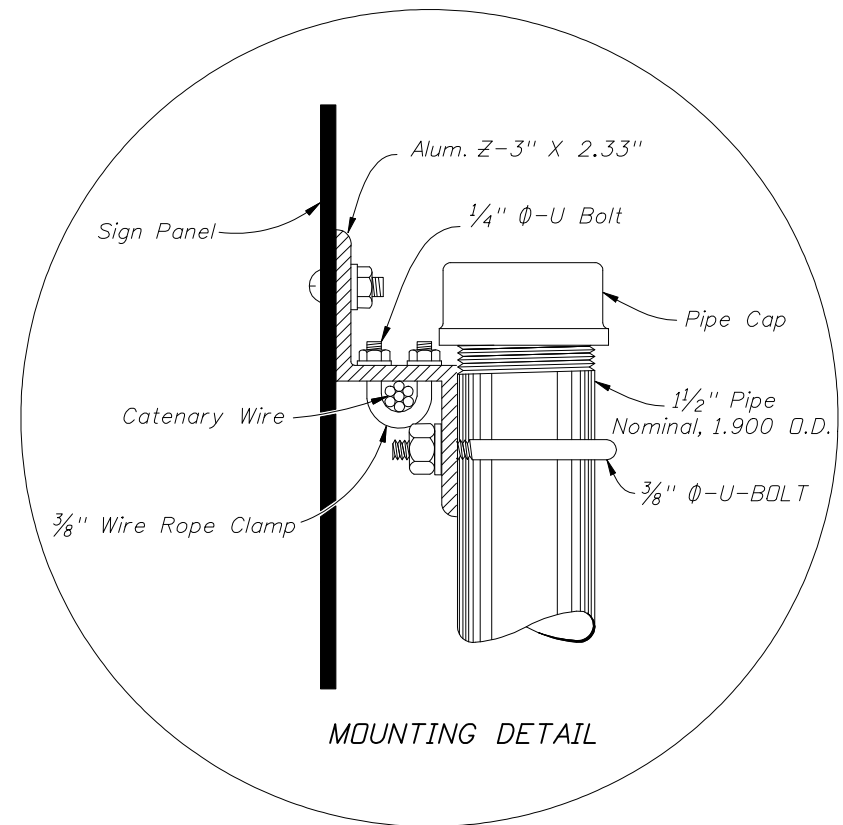

MOUNTING DETAIL

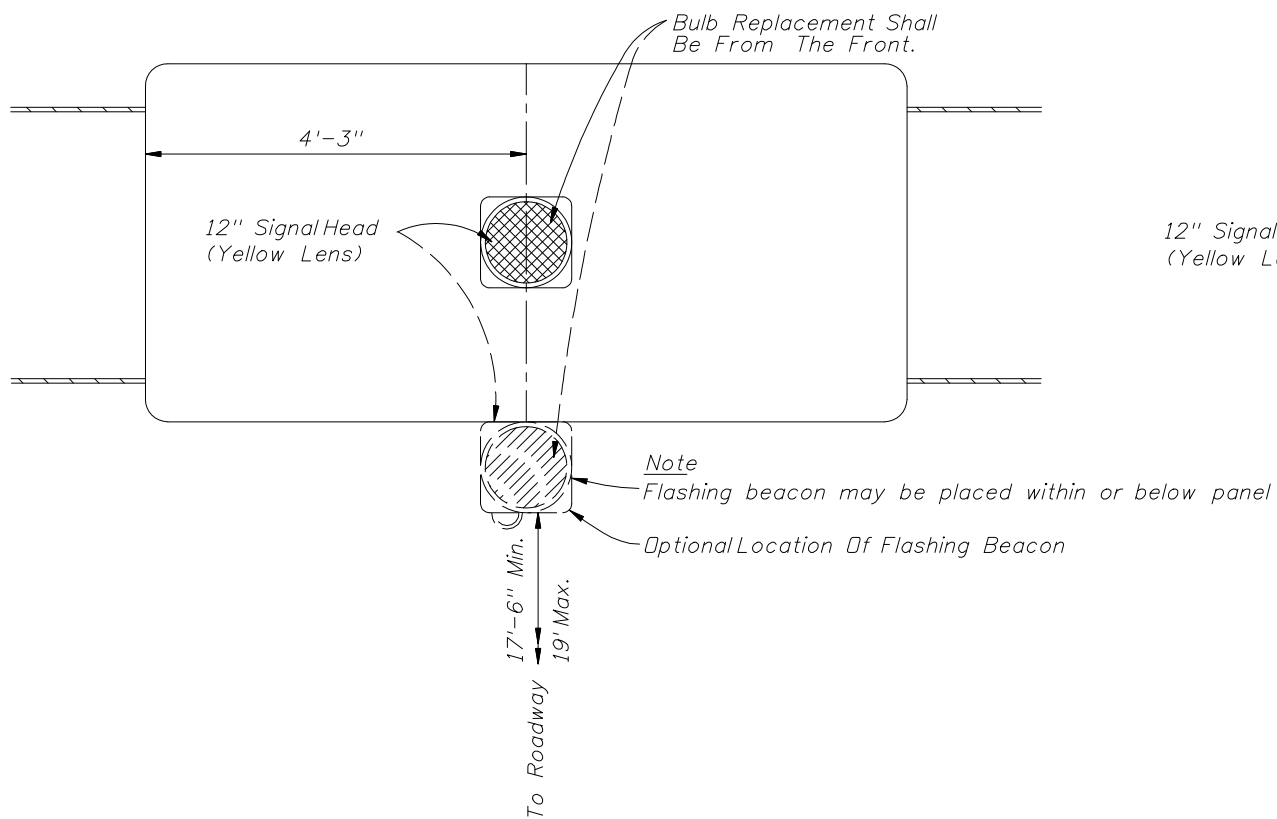

FRONT VIEW

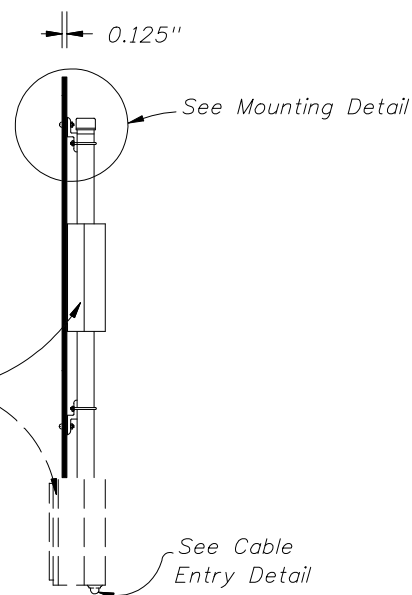

SIDE VIEW

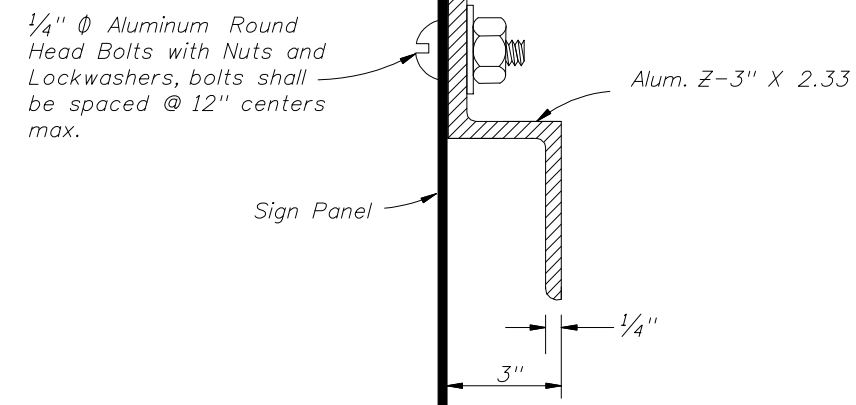

Z SECTION DETAIL

Flasher unit and cabinet to be placed on the strain pole supporting overhead sign assembly or on service pole. The flasher unit not to overhang private property or sidewalk.

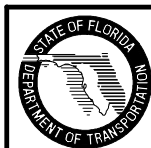

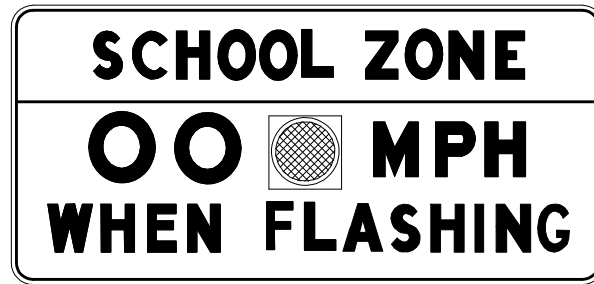

* 12" Signal Head
(Yellow Lens)

FTP-31-06

OVERHEAD STANDARD

* Flashing Beacon May Be Placed Within Or Below Panel

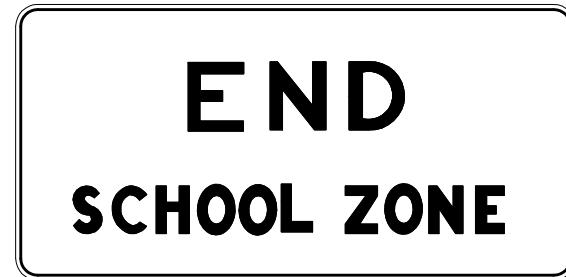

FTP-32-06



FTP-38-06



FTP-33-06

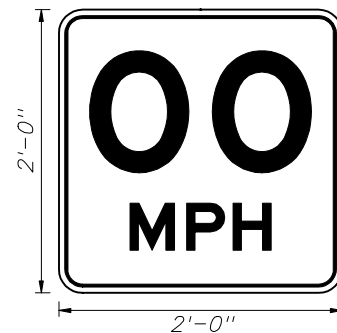

W13-1

SPEED LIMIT ASSEMBLY

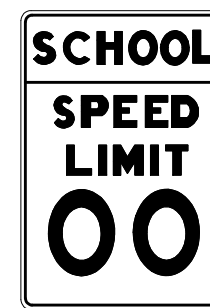

FTP-35-06

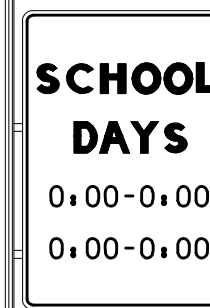

FTP-30-06



S1-1

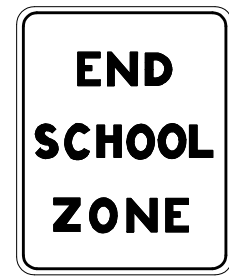

FTP-34-06

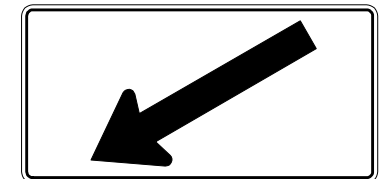

W16-7



W16-9P



S4-5



S3-1

12" Signal Head
(Yellow Lens)



S5-1

Ground Mount Standard

Notes:

- Standard size signs should be used whenever possible. Minimum sizes may be used only on low volume, low speed (less than 35 mph) streets. Special sizes should be used on expressway facilities where special emphasis is needed.
- The value of the actual school zone speed limit shall be determined by the District Traffic Operations Engineer in cooperation with local school superintendents. In no case shall it be less than the 15 mph min. as set by law.
- See Index No. 17355 for sign details.
- When fluorescent yellow-green background color is used, a systematic approach featuring one background color within a zone or area should be used. The mixing of standard yellow and fluorescent yellow green background within a zone should be avoided.

Note:

Existing ground mount school speed limit signs utilizing a single 8" min. size beacon or two 6" min. size beacons inside the sign border are considered meeting the standard. However, replacement or upgrading of these school speed limit signs shall conform to the above standard. Numerical speed limit displayed shall be established by appropriate regulatory authorities.



2010 FDOT Design Standards

SCHOOL SIGNS & MARKINGS

Last Revision	Sheet No.
07/01/09	6 of 6
Index No.	
17344	

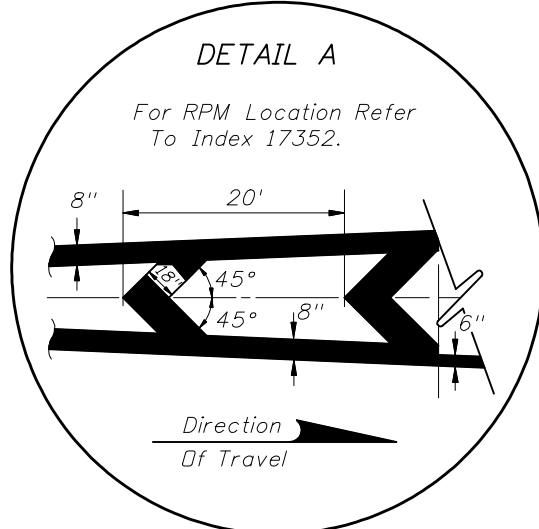
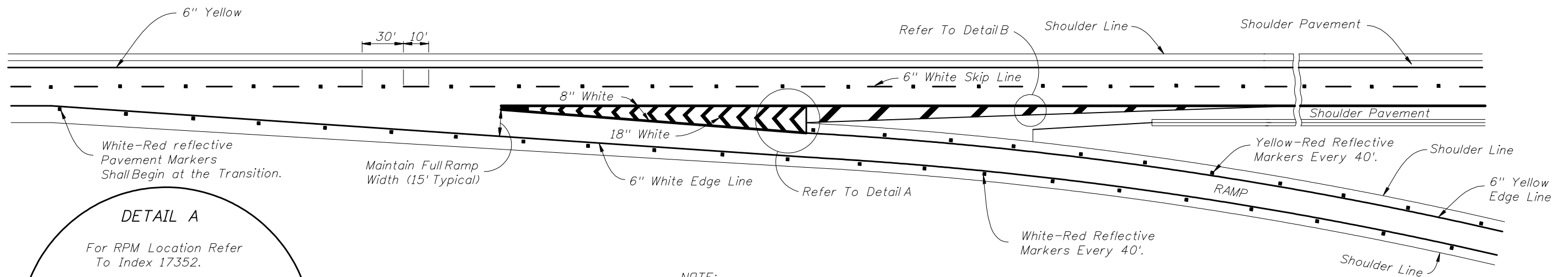

NOTE:
Reflective pavement markers
are installed adjacent to the
edge line.

NORMAL TAPERED EXIT
(TWO THRU LANES)

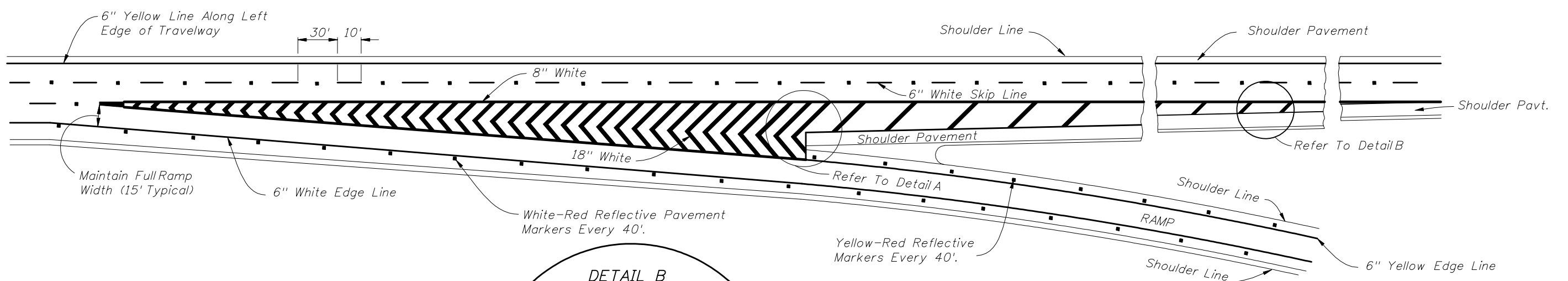

NOTE:
In advance of lane drops at exit ramps a special marking pattern
may be used to distinguish the lane drop situation from a normal
exiting ramp or auxiliary lane.
A typical special marking for lane drops consist of 8" wide by 3'
long white stripes separated by 9' gaps. If used, this special
marking should begin 1/2 mile in advance of the theoretical gore
point. Where lane changes may cause conflicts, an 8" wide
solid white channelizing line may be extended 300' upstream
from the theoretical gore. (MUTCD Section 3B.05).

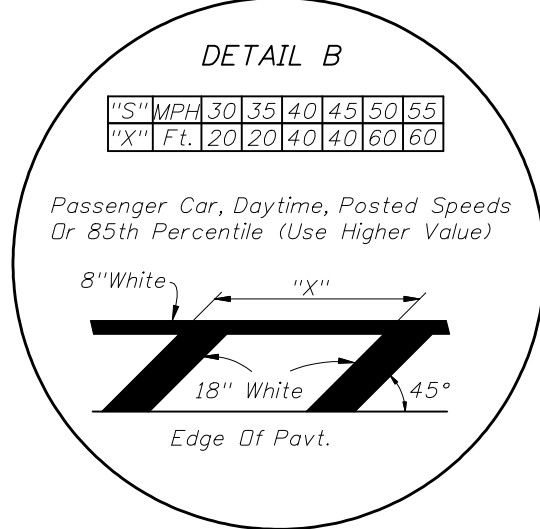

NORMAL TAPERED EXIT ONLY
(TWO THRU LANES - THREE APPROACH LANES)

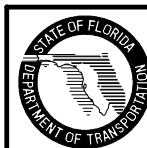

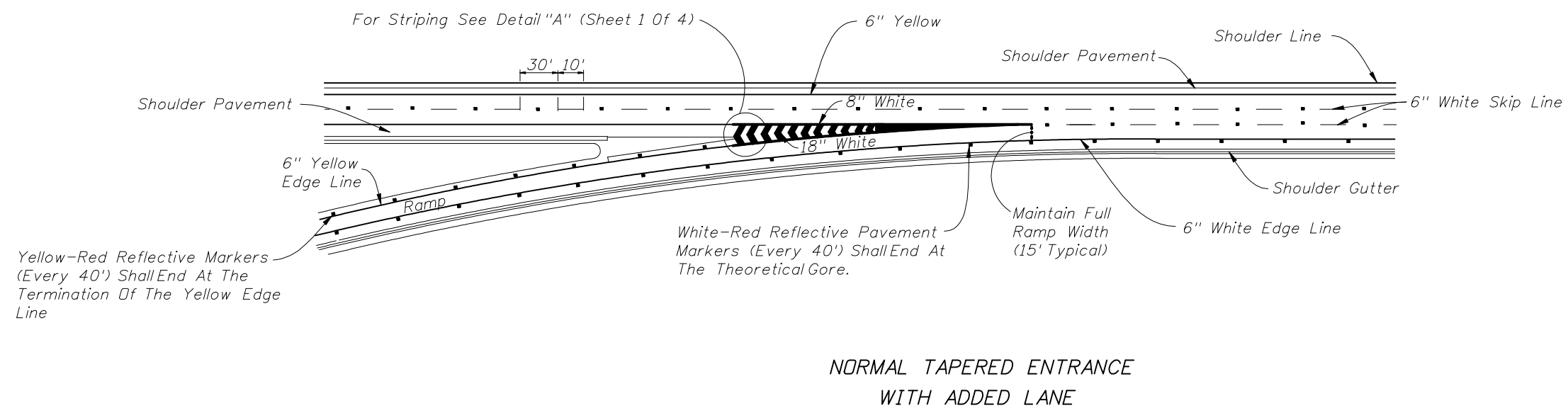
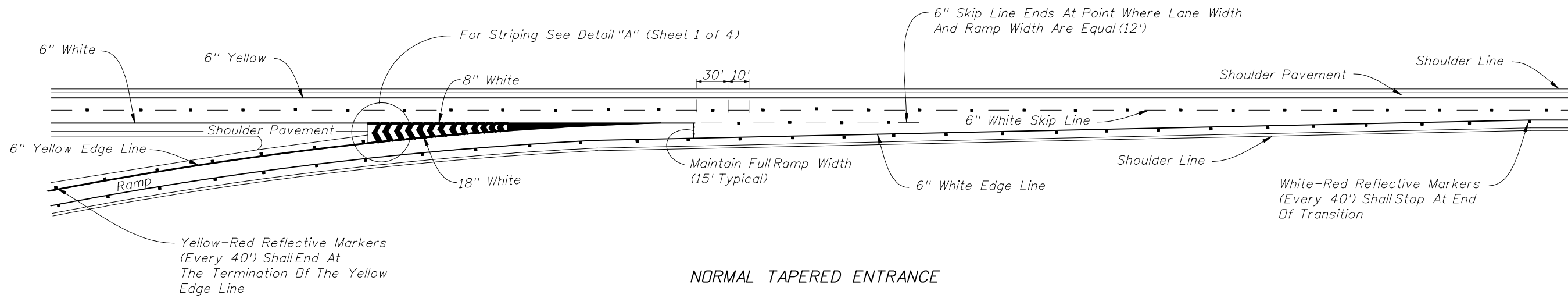

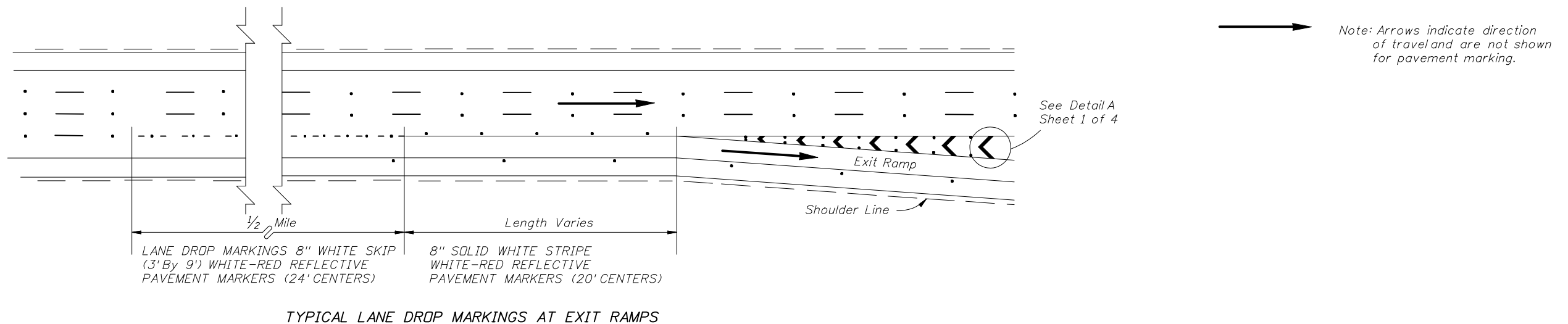
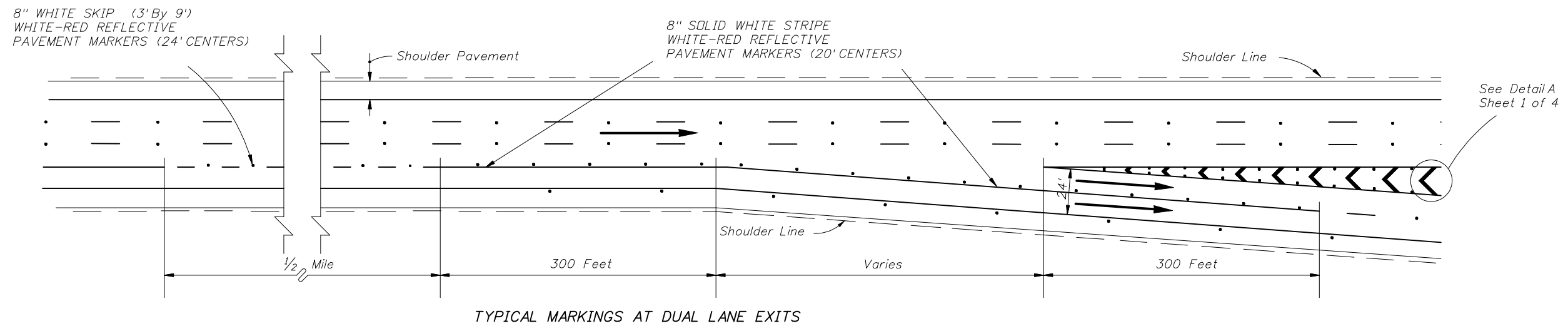
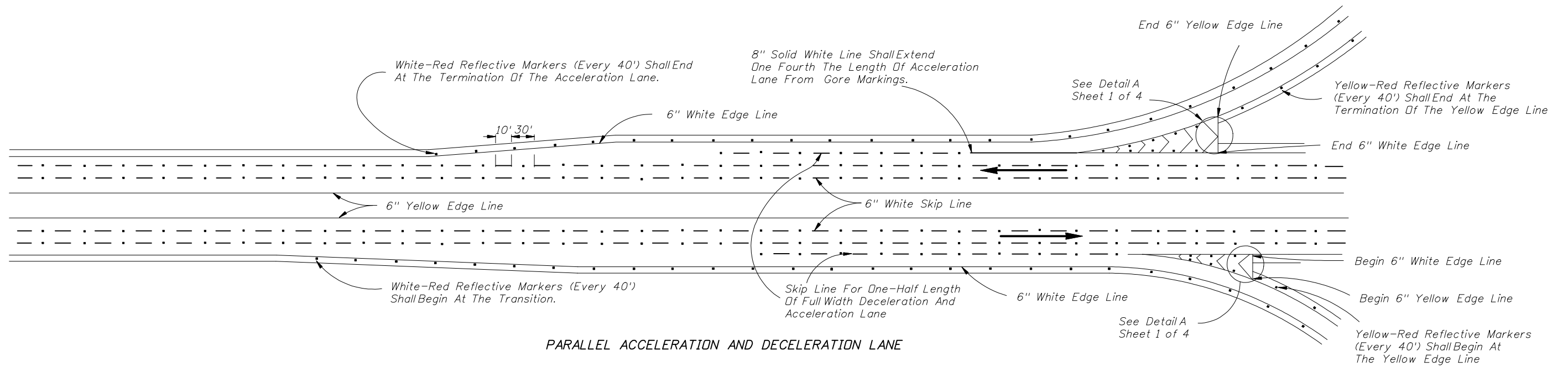

Notes:

1. Post delineators spaced at 40' on curves of the entrance and exit of ramps. The spacing on the tangent portion of the ramp section shall be 300'. All delineators are to be setback 4' from shoulder break. Post delineators should not be discontinued in sections with guardrail.

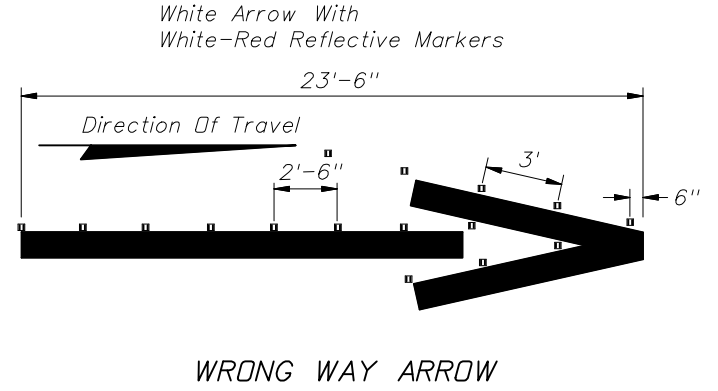
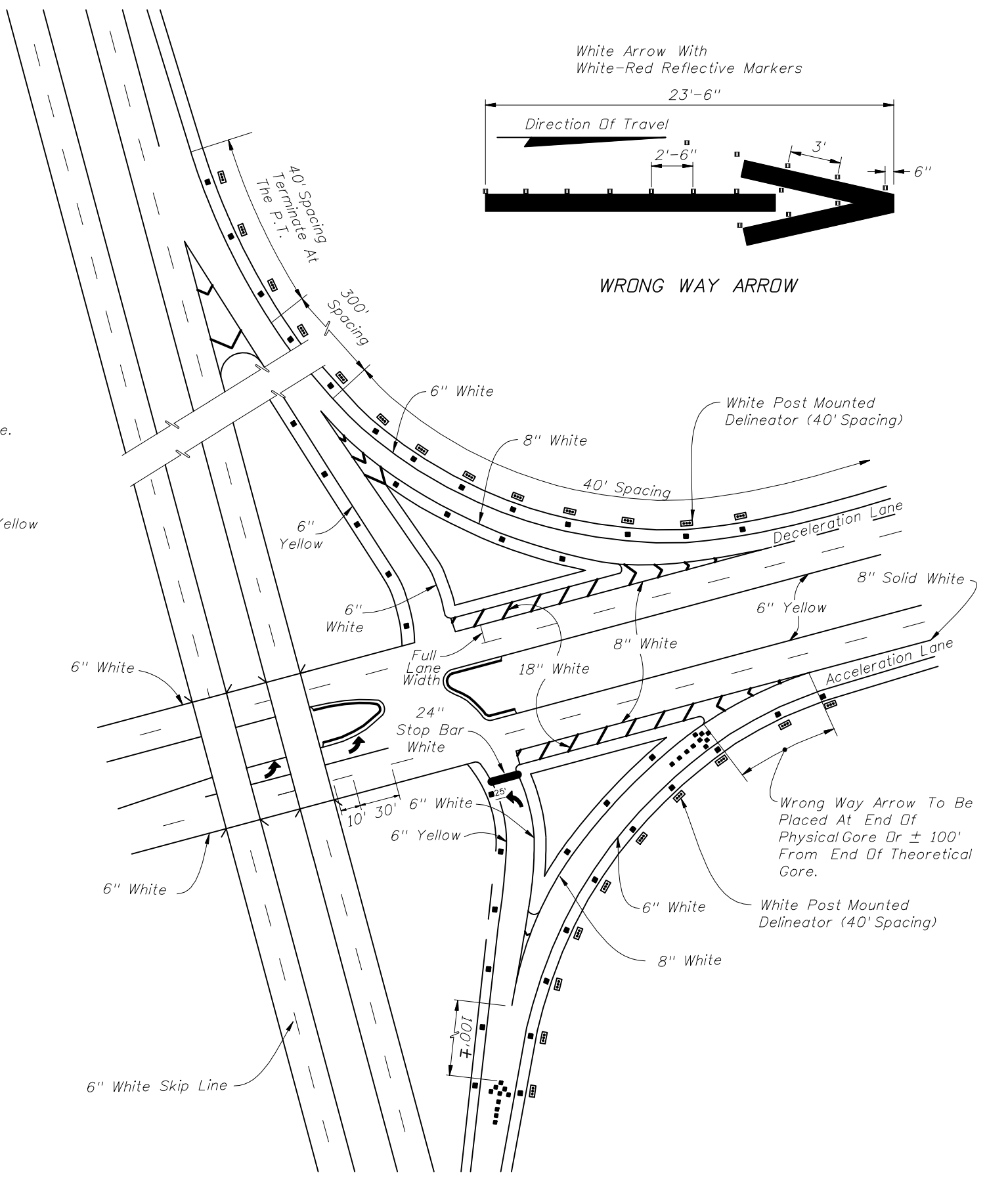
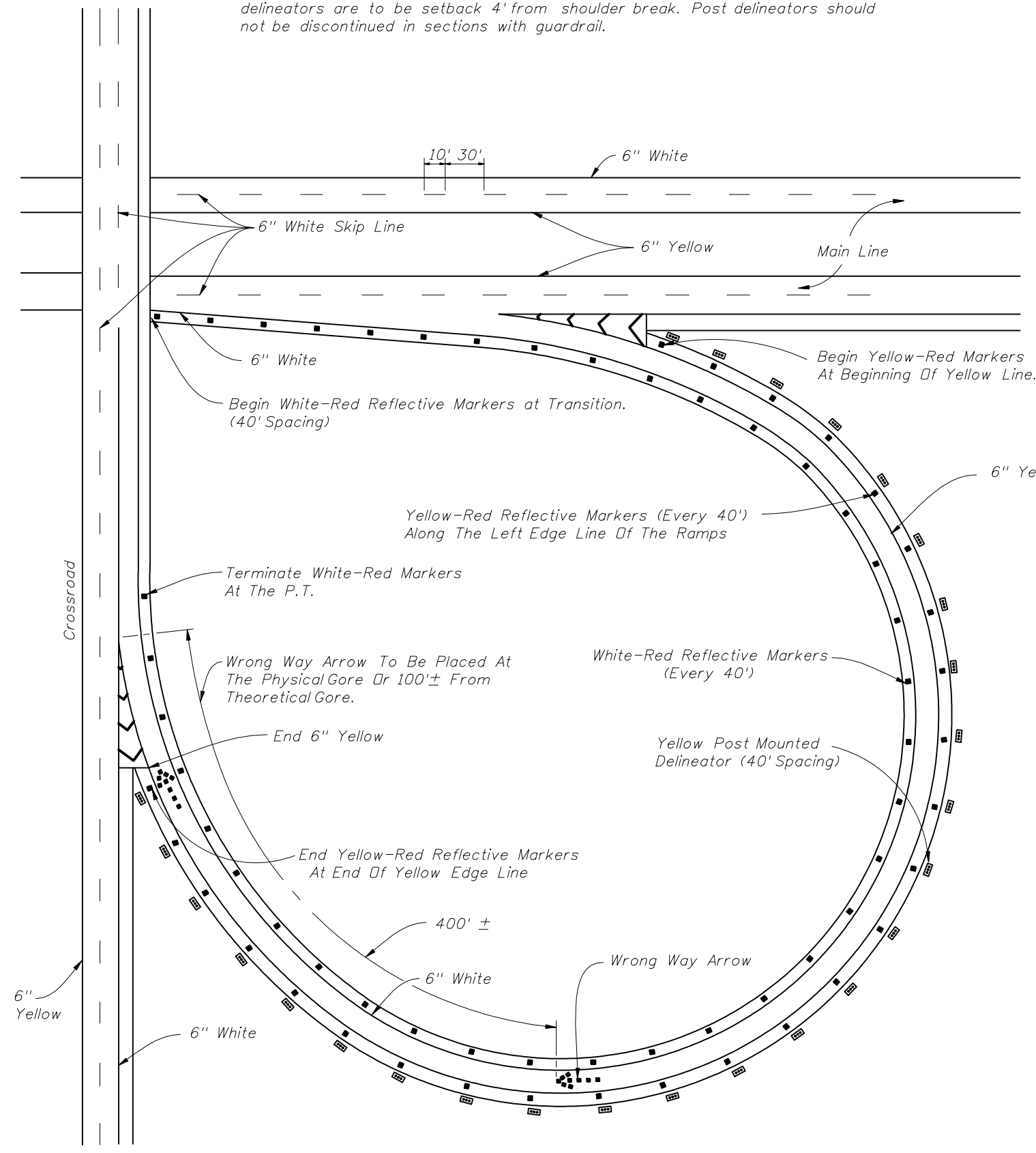

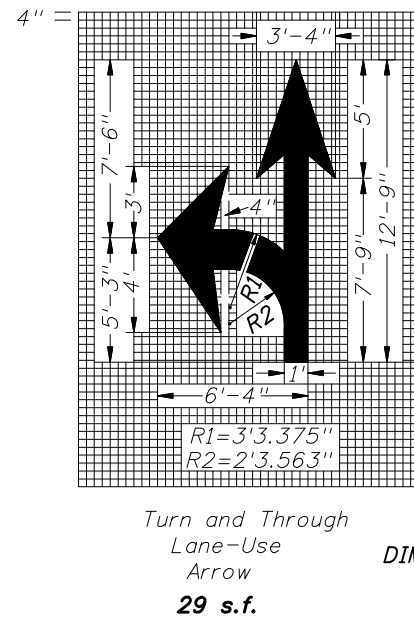
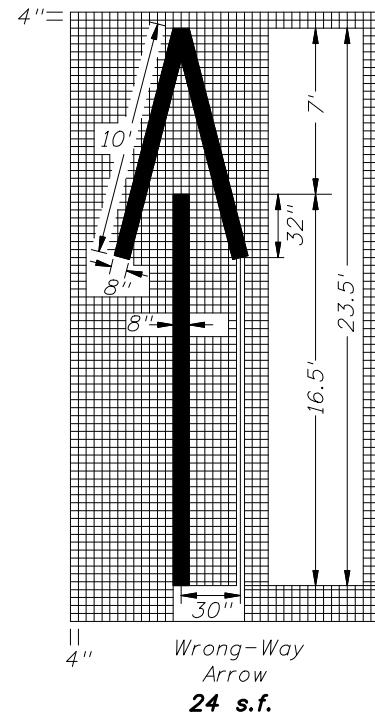
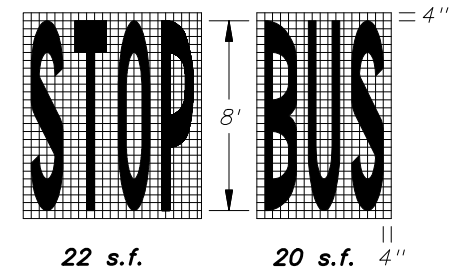
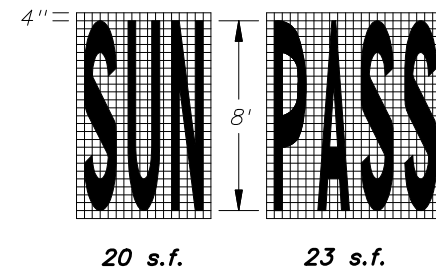
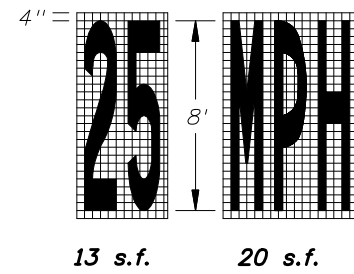
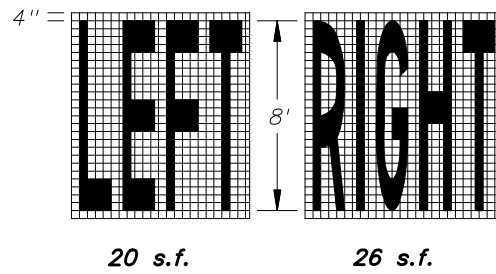
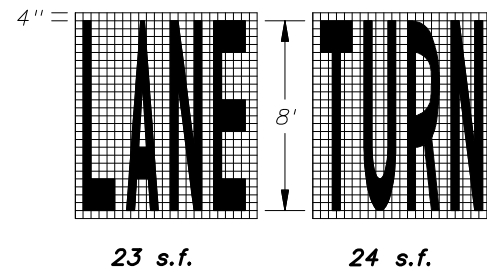
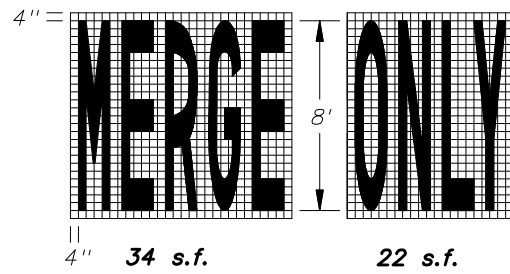

DIMENSIONS ARE WITHIN 1" ±

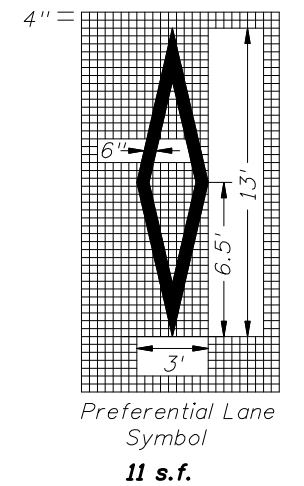
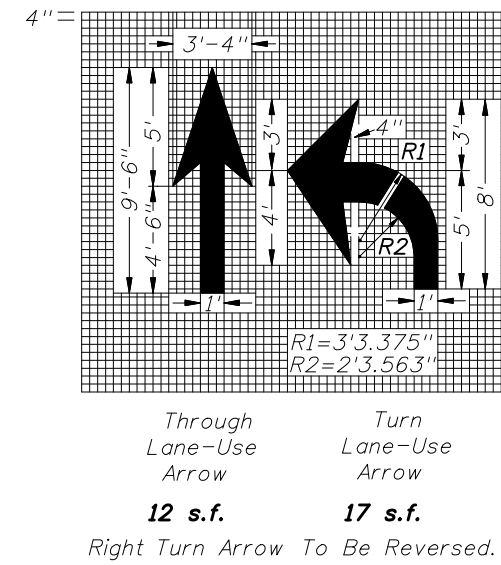
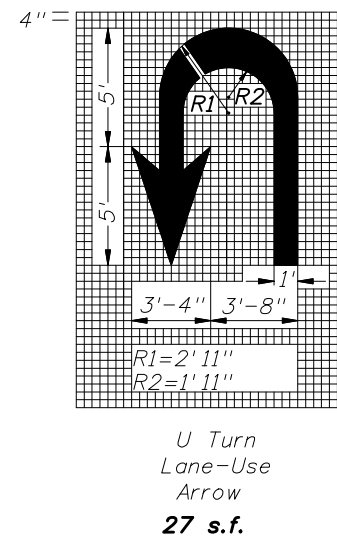

PAVEMENT ARROW AND MESSAGE DETAILS

NOTE: When arrow and pavement message are used together, the arrow shall be located down stream of the pavement message and shall be separated from the pavement message by a distance of 25' (Base of the arrow to the base of the message). Stop message shall be placed 25' from back of stop line.

TYPES OF PERMANENT LONGITUDINAL LINES

BASIC COLOR RULE:

White lines separate traffic in the same direction. Yellow lines separate traffic in opposing directions. Yellow dotted lines may be used in special cases. Black may be used in combination with white for skip lines where a light-colored pavement does not provide sufficient contrast with the markings.

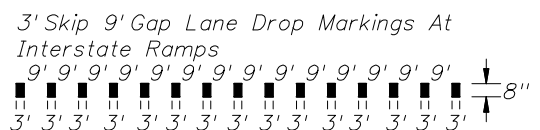
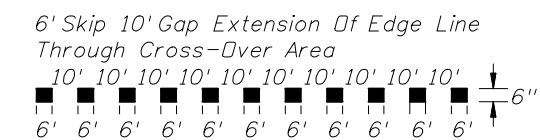
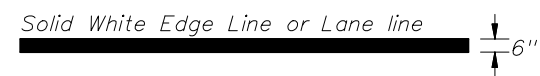
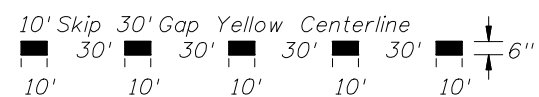
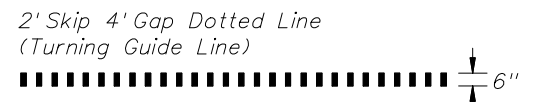

CONTRAST MARKINGS

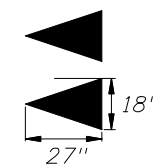
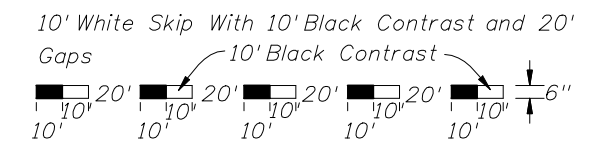
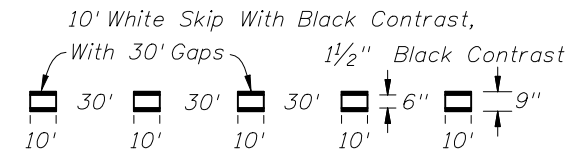

Yield Lines 5-18" X 27" White triangles facing traffic equally spaced within travel lane with 1 additional triangle using same spacing when a bike lane is present.



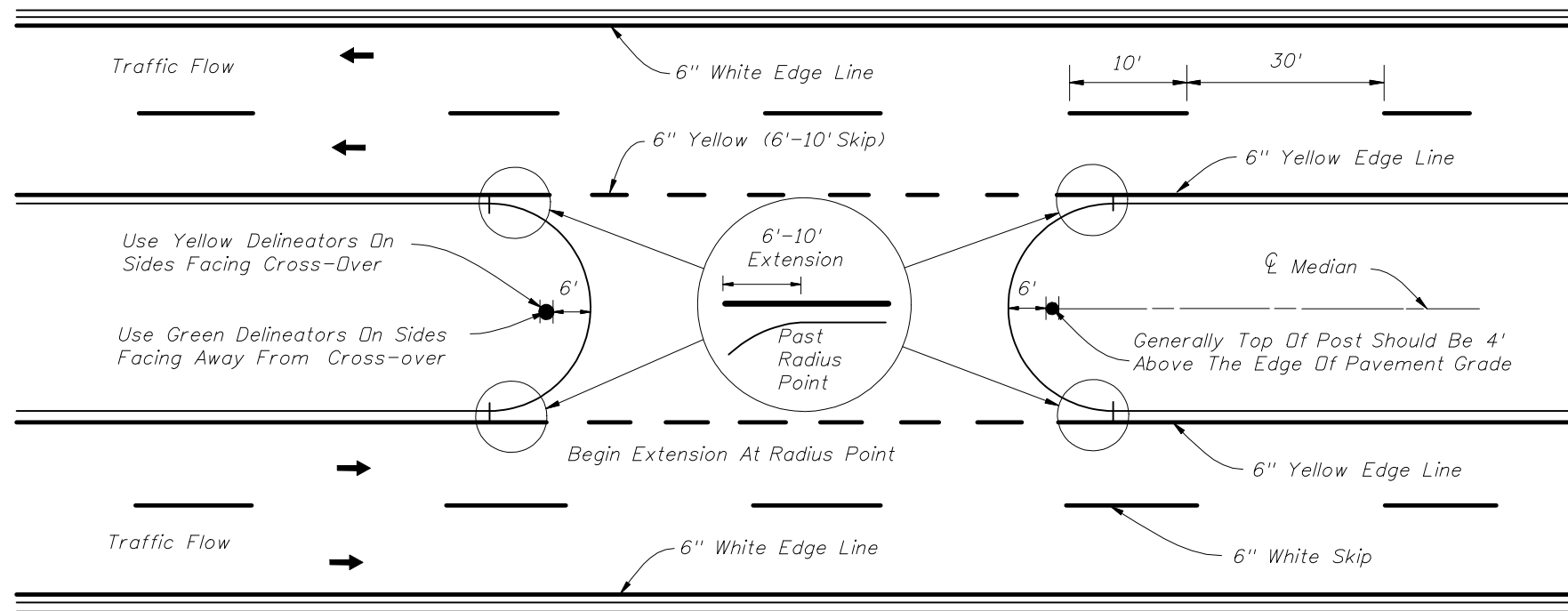

PAVEMENT MARKINGS AND DELINEATORS FOR MEDIAN CROSS-OVER

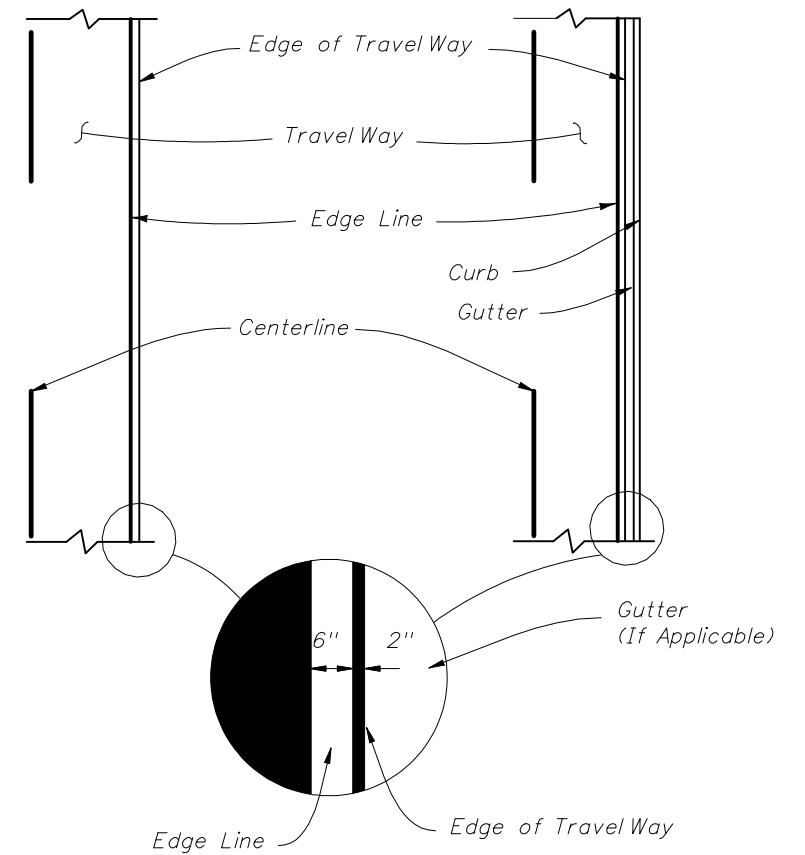

PLACEMENT OF EDGE LINES

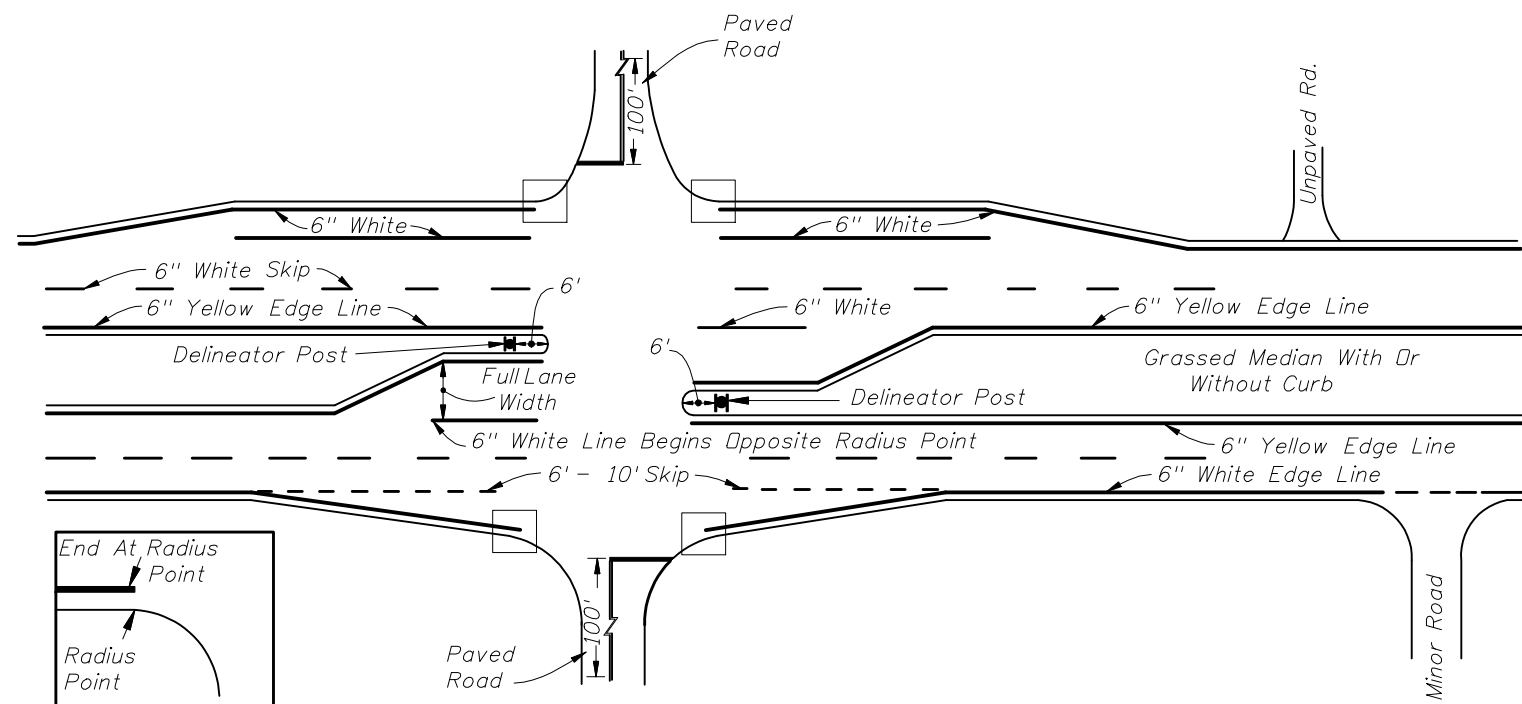

PAVEMENT MARKINGS FOR INTERSECTIONS WITH MAJOR AND MINOR ROADS

NOTE:

Markings applied to median noses shall be yellow in color.

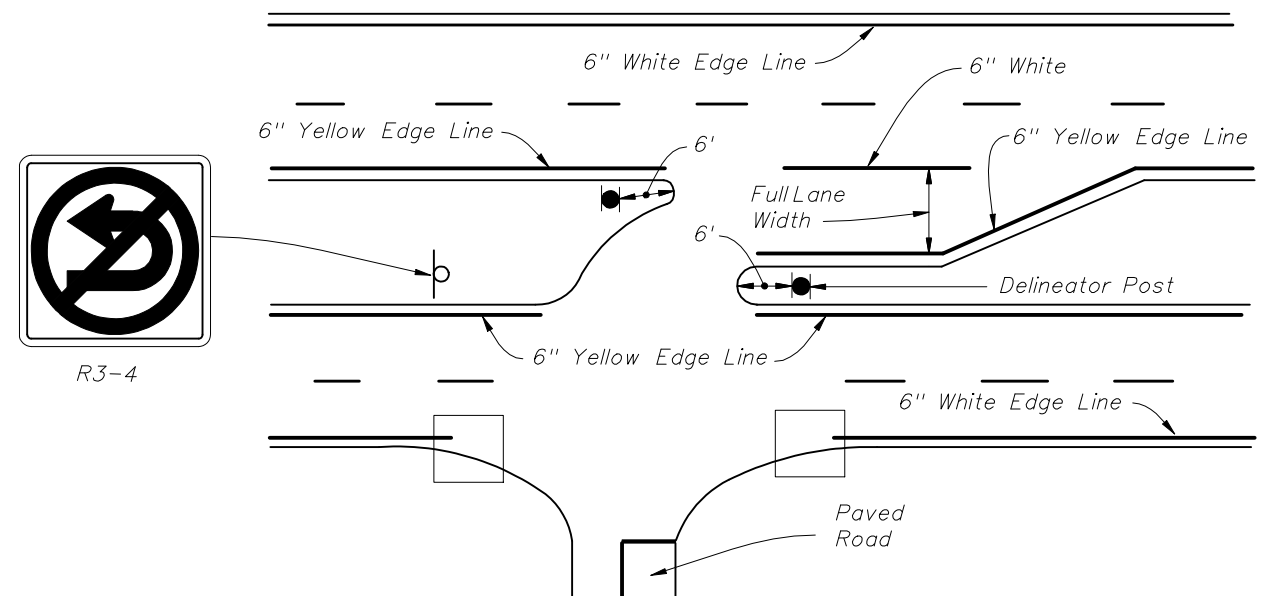

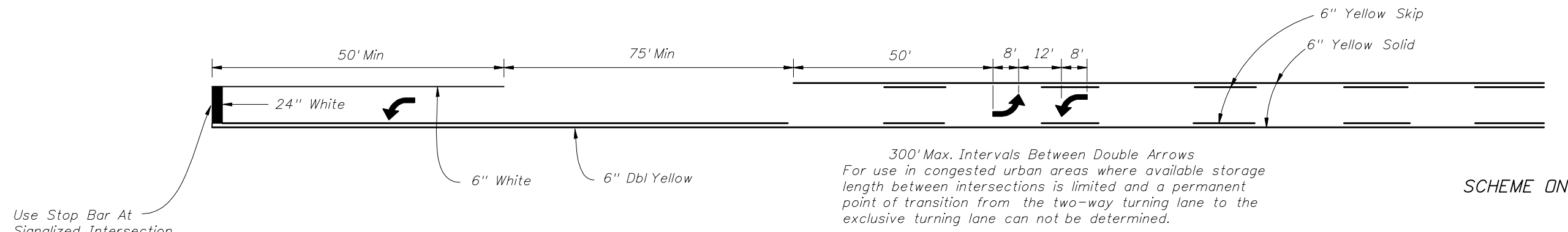

SCHEME ONE

Use Stop Bar At Signalized Intersection Only

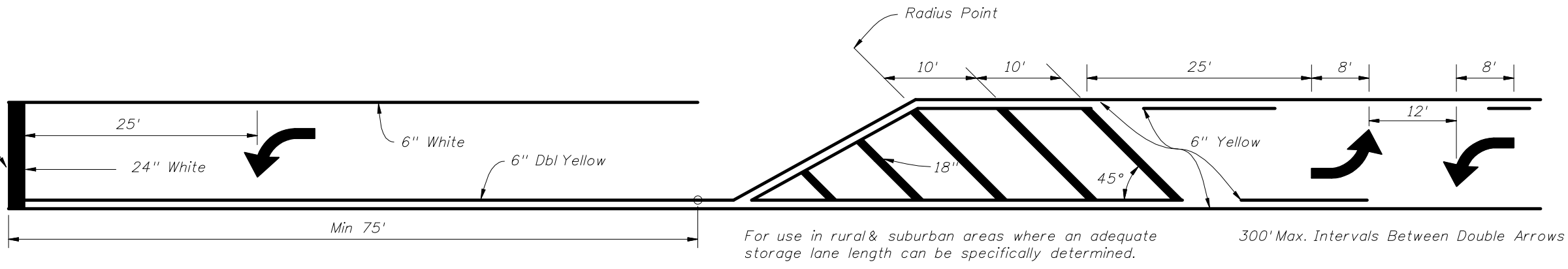

SCHEME TWO

(WITH SINGLE LANE LEFT TURN CHANNELIZATION)
TWO WAY LEFT TURN LANE

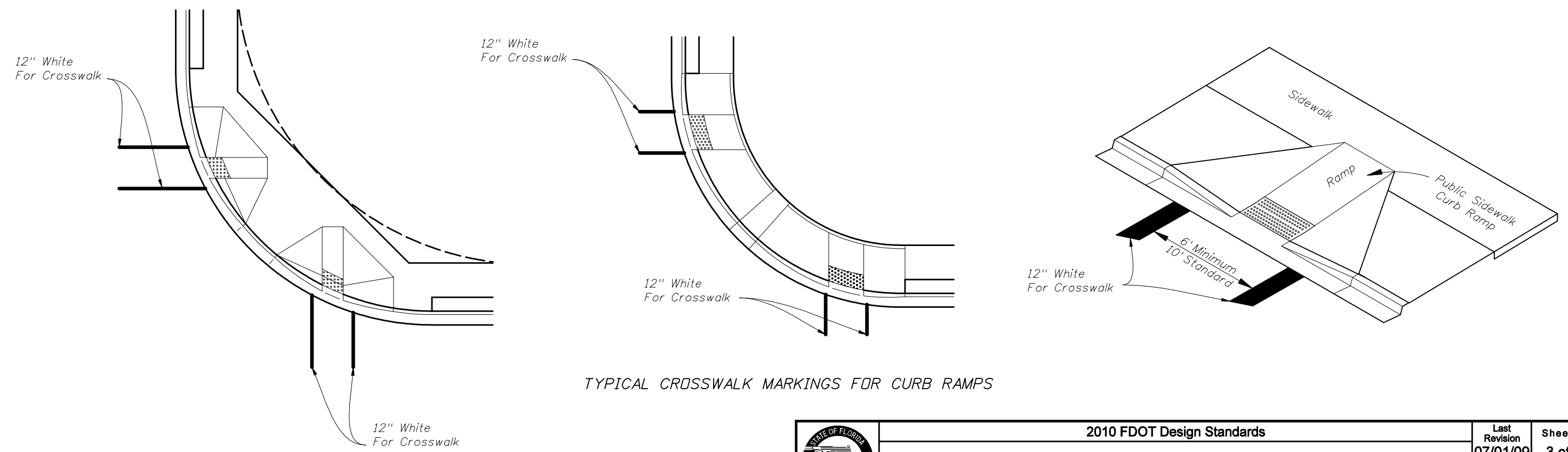

TYPICAL CROSSWALK MARKINGS FOR CURB RAMPS



6'-10' Skip
6" White

These markings may be used for locations with restricted left turn lengths, only when called for in plans.

6" Dbl Yellow

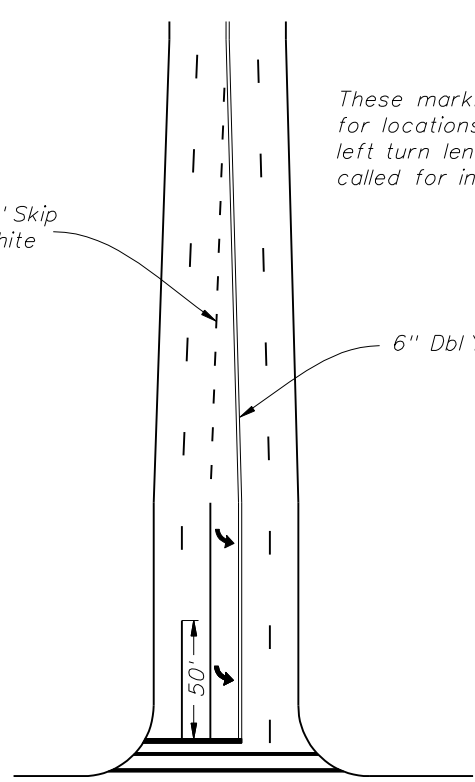

RESTRICTED LEFT TURN MARKING

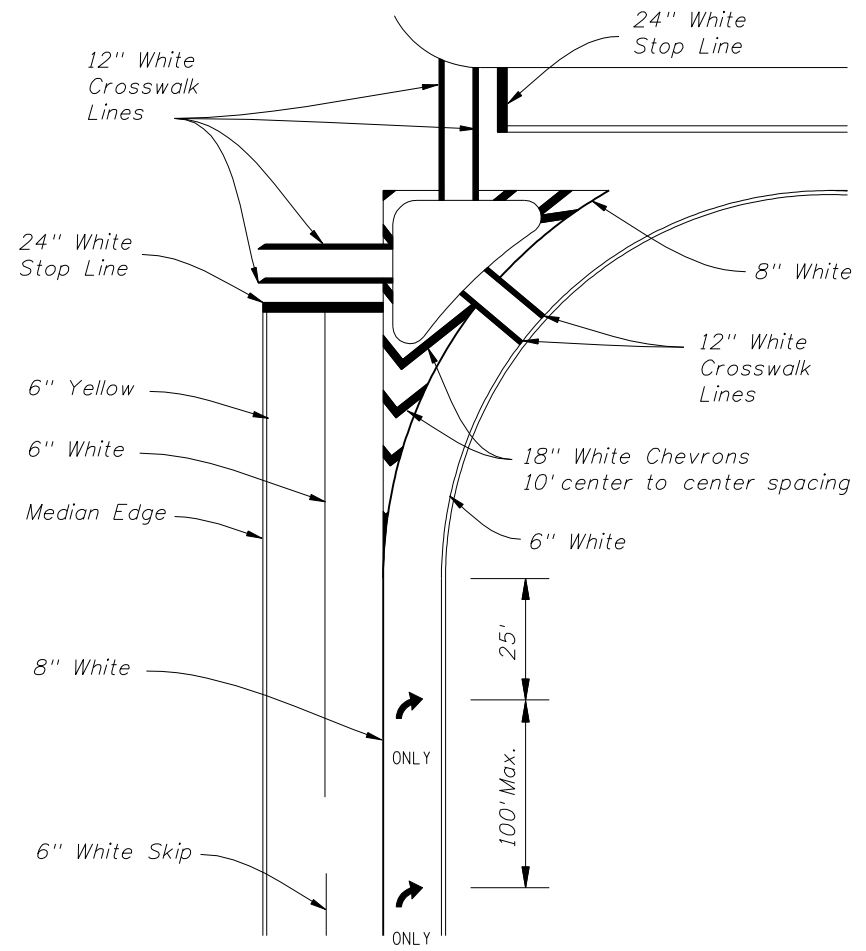

RIGHT TURN LANE DROP AND ISLAND DETAILS
LEFT TURN LANE DROP IS MIRROR IMAGE

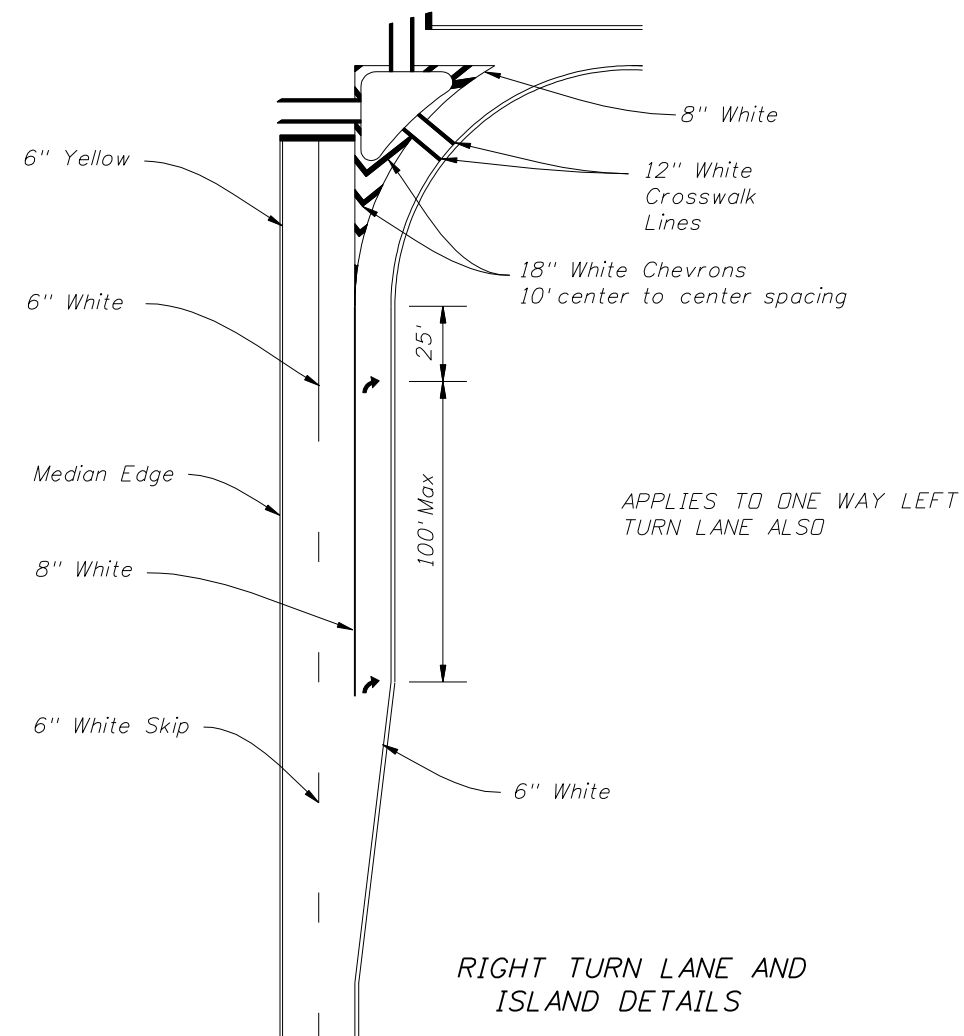

RIGHT TURN LANE AND ISLAND DETAILS

100' Minimum or as determined by $L=WS$

$$(L = \frac{WS^2}{60} < 45 \text{ mph}) \text{ where}$$

W is the lateral offset in feet and S is the 85th percentile speed in miles per hour (speed limit)

For left turn storage lane detail see sheet 2 of 13 of this index.

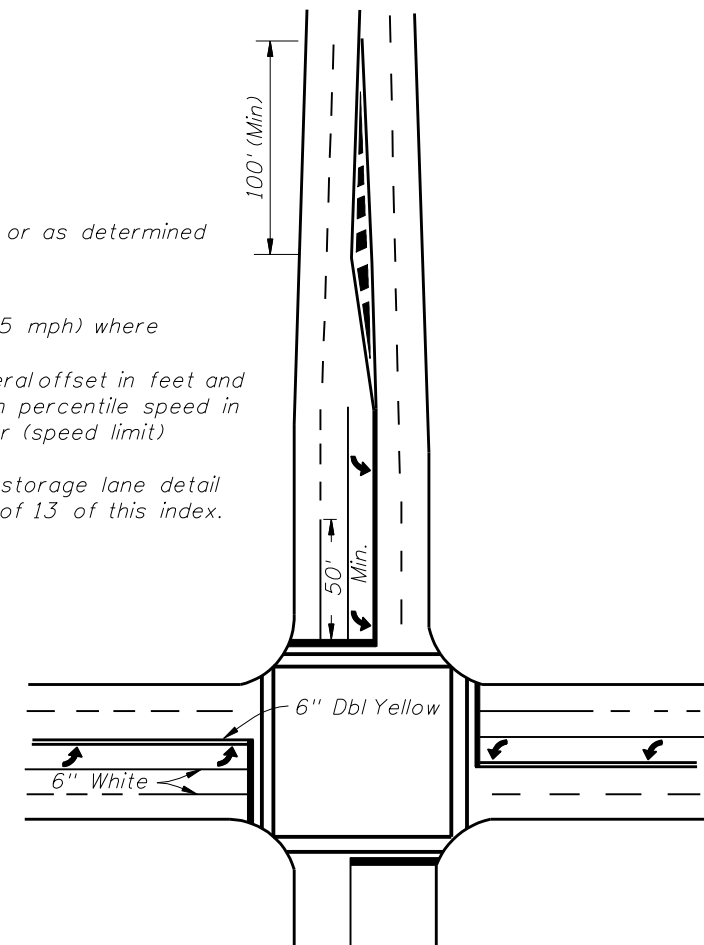

TYPICAL INTERSECTION 2 THRU LANES PLUS LEFT TURN LANE, WITH CROSSWALK

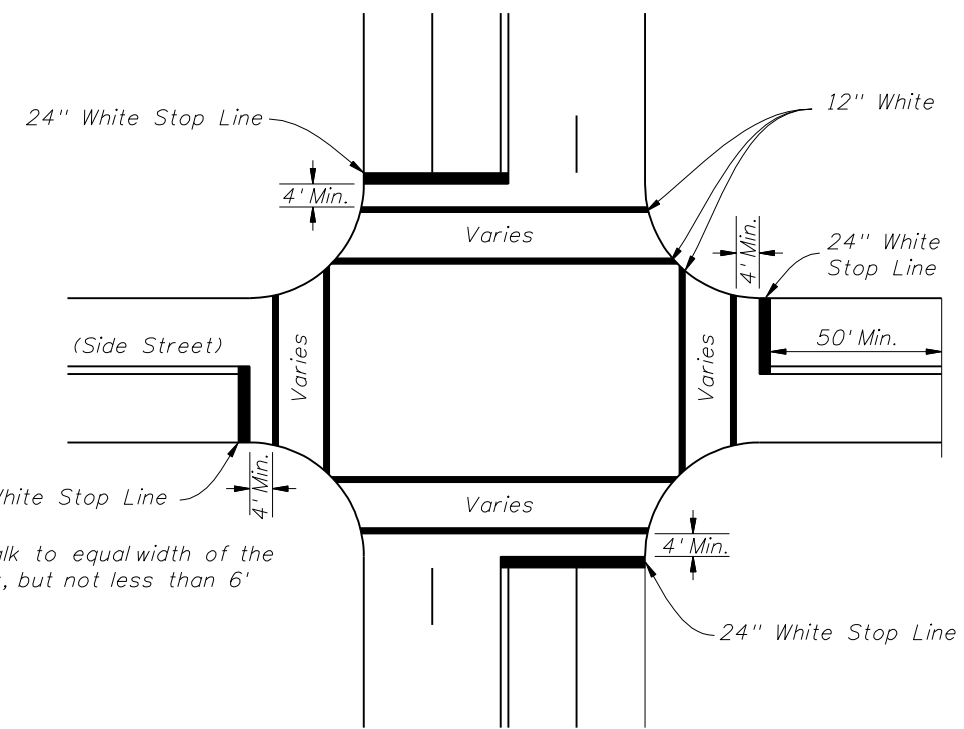

STOP BARS, CROSSWALKS AND DOUBLE CENTER LINE DETAILS

NOTES:

1. When public sidewalk curb ramps are present, refer Index 17344 and Index No. 304 for crosswalk widths.
2. Double yellow longitudinal center lines on all roadway approaches shall be extended back 100' for projects involving intersection improvements only.
3. When specified, "stop" message shall be placed 25' back of stop lines.



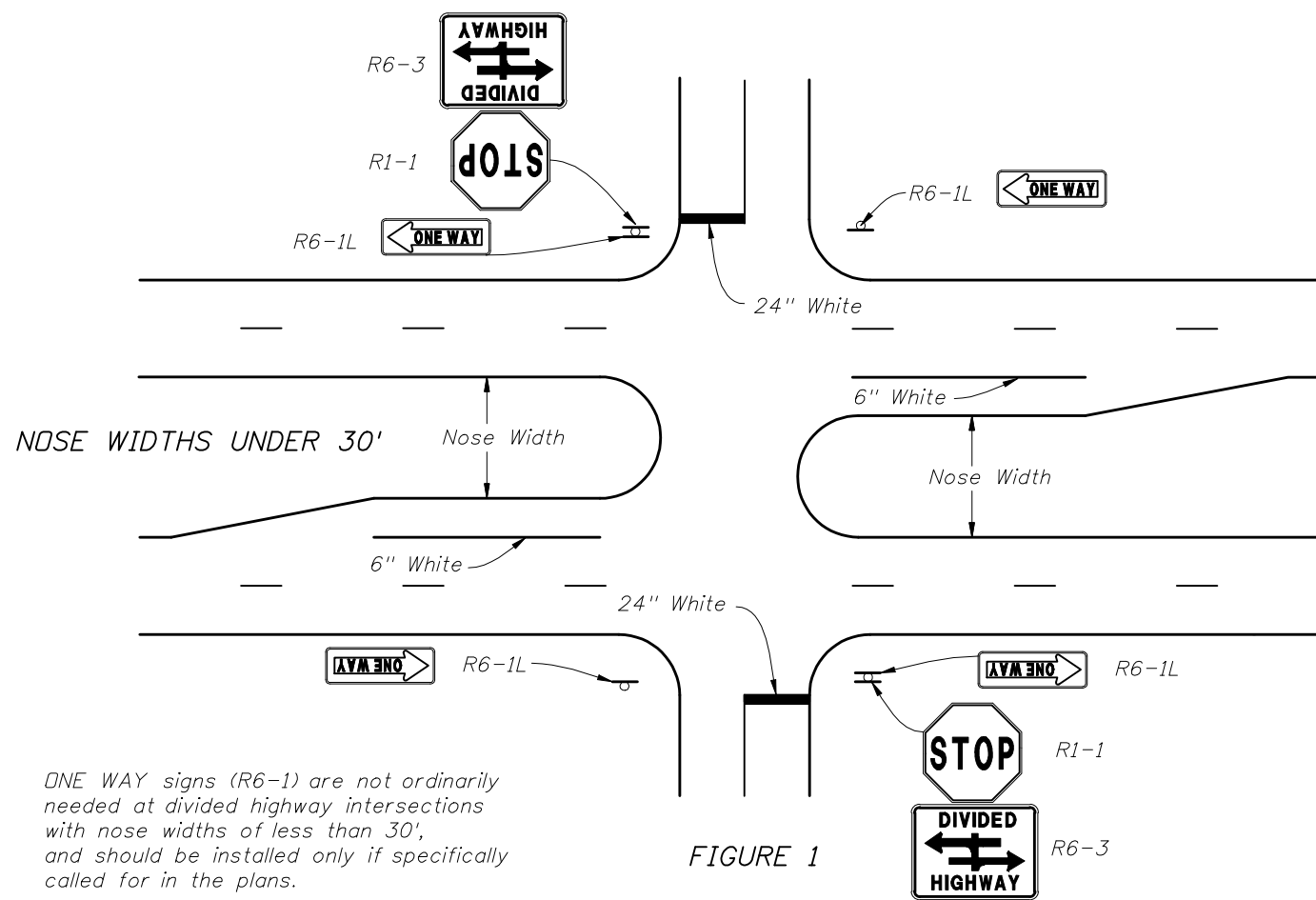

FIGURE 1

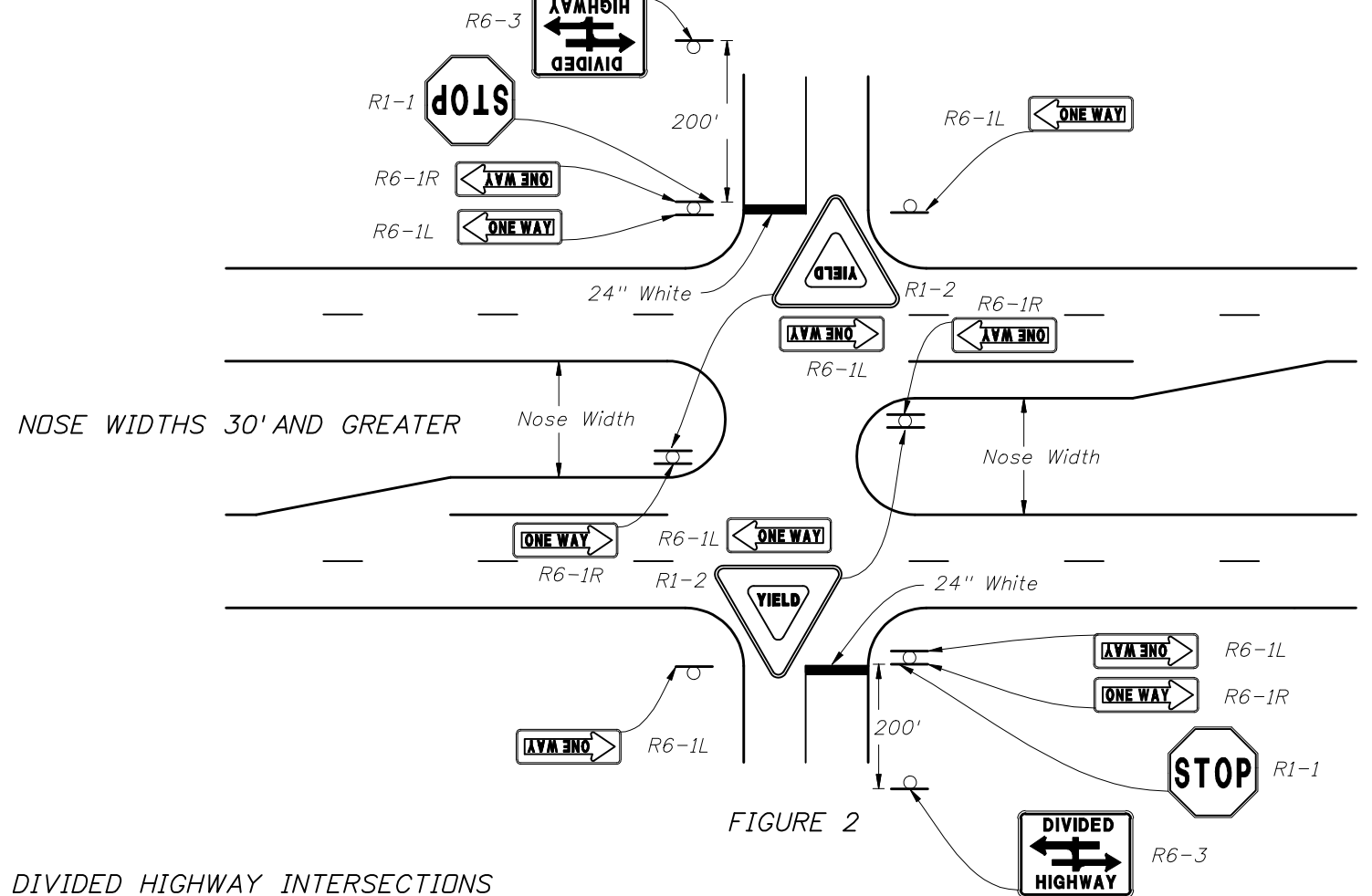
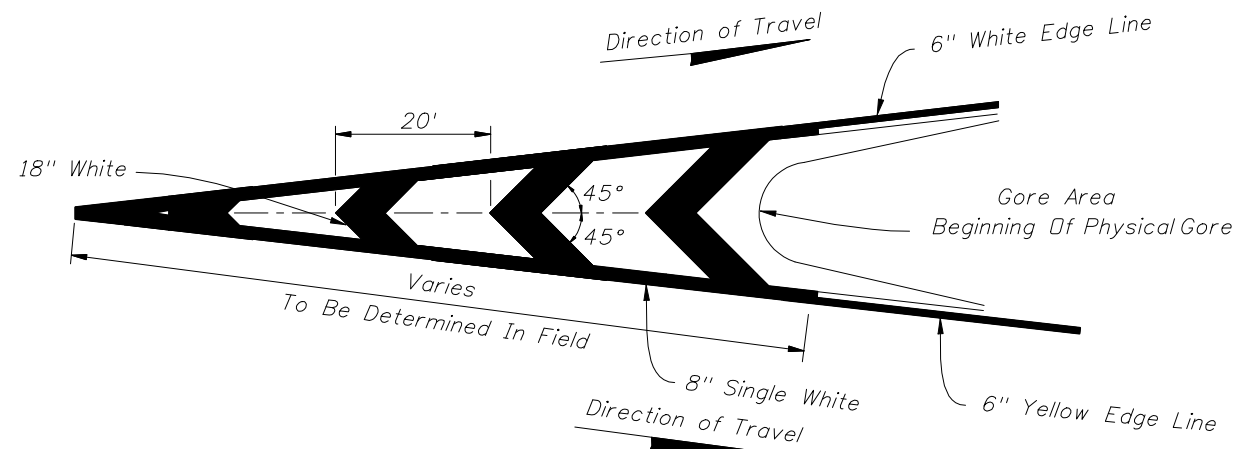
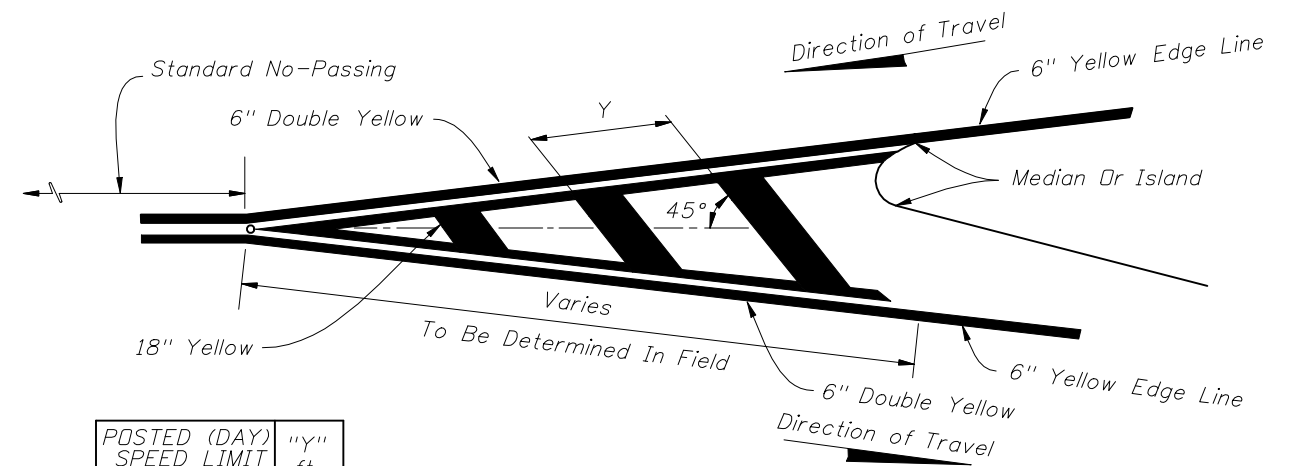

FIGURE 2

ONE-WAY SIGNS ON DIVIDED HIGHWAY INTERSECTIONS



PAVEMENT MARKINGS FOR TRAFFIC CHANNELIZATION AT GORE
(TRAFFIC FLOWS IN SAME DIRECTION)



POSTED (DAY) SPEED LIMIT MPH	"Y" ft.
30 OR LESS	10
35	20
40	20
45	30
50 OR MORE	40

PAVEMENT MARKING FOR TRAFFIC SEPARATION
(TRAFFIC FLOWS IN OPPOSING DIRECTIONS)

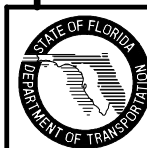

TYPICAL TRANSITION MARKING
 COLOR SHALL BE THE SAME AS RESPECTIVE EDGE LINE

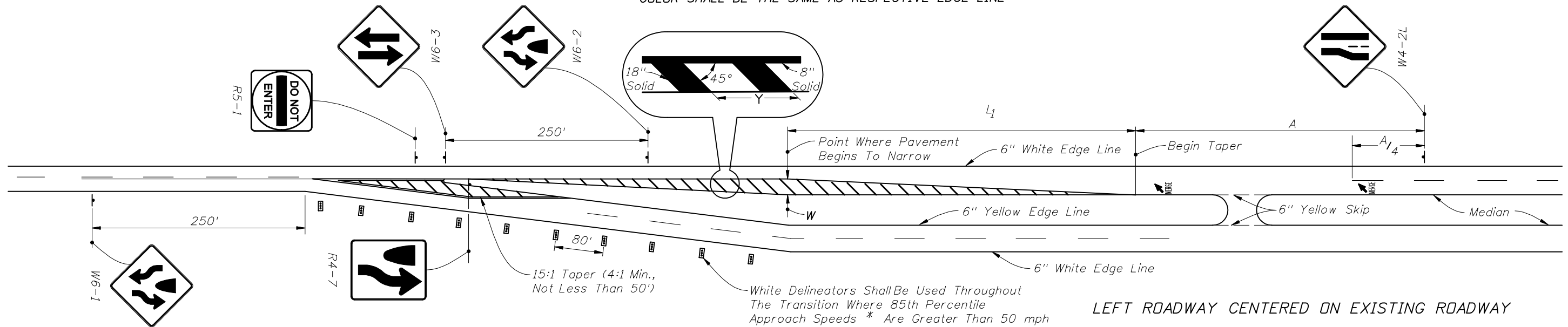

LEFT ROADWAY CENTERED ON EXISTING ROADWAY

** W * S	TRANSITION DISTANCE L ₁ (FEET)						
MPH	8	9	10	11	12	13	14
30	120	135	150	165	180	195	210
35	165	185	205	225	245	265	285
40	215	240	270	295	320	350	375
45	360	405	450	495	540	585	630
50	400	450	500	550	600	650	700
55	440	495	550	605	660	715	770
60	480	540	600	660	720	780	840
65	520	585	650	715	780	845	910

SPEED* MPH	"A" (FT.)
55	950
50	850
45	750
40	650
30	450

POSTED (DAY) SPEED LIMIT MPH	"Y" (FT.)
30 OR LESS	10
35	20
40	20
45	30
50 OR MORE	40

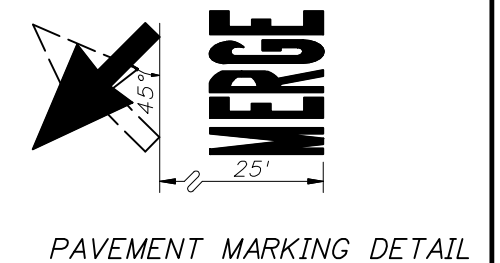
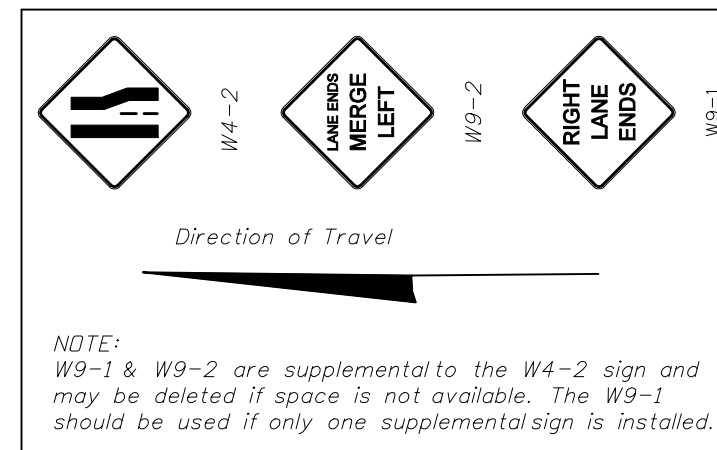

$L_1 = WS$ (45 MPH or Greater) *Design Speed
 $L_1 = \frac{WS^2}{60}$ (<40 MPH) **Lateral offset

White Delineators Shall Be Used Throughout The Transition Where 85th Percentile Approach Speeds* Are Greater Than 50 mph.

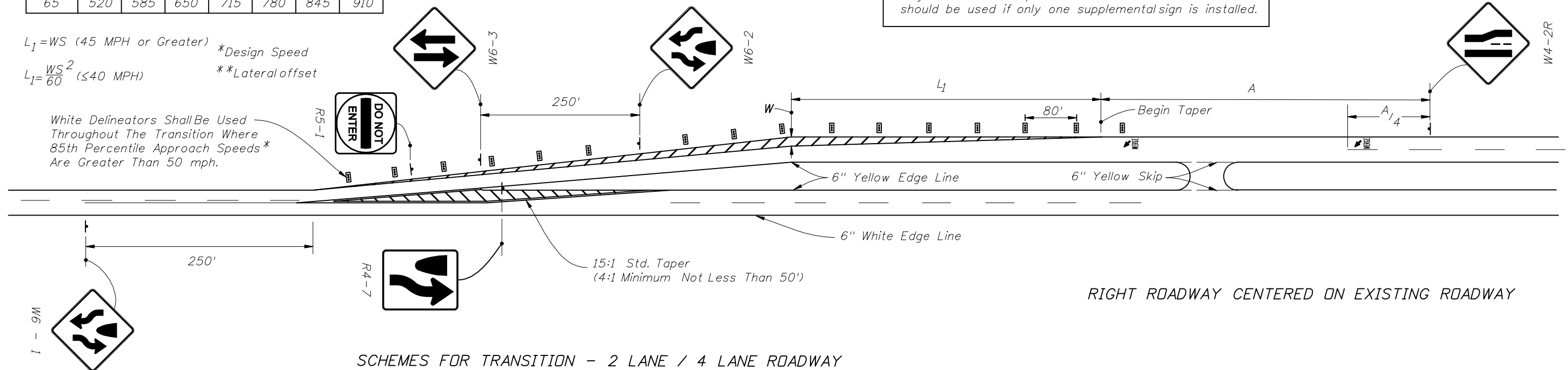

RIGHT ROADWAY CENTERED ON EXISTING ROADWAY

SCHEMES FOR TRANSITION - 2 LANE / 4 LANE ROADWAY



2010 FDOT Design Standards

SPECIAL MARKING AREAS

Last Revision: 07/01/09
 Sheet No.: 6 of 14
 Index No.: 17346

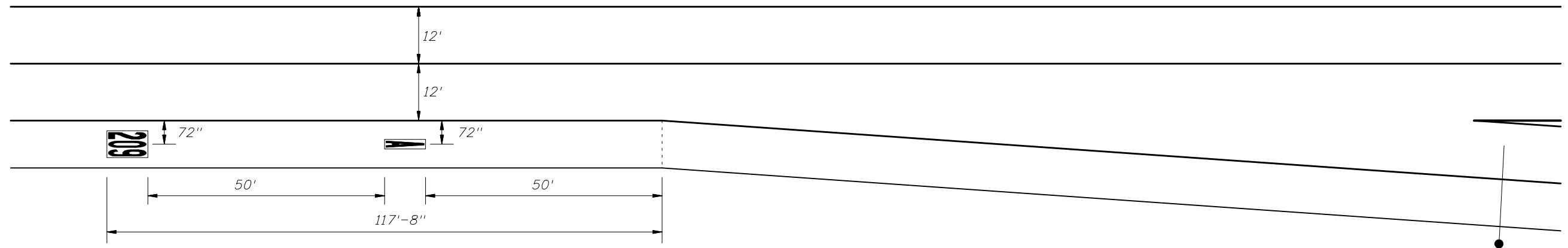

LAYOUT FOR 1, 2 AND 3 DIGIT NUMBERS AND LETTERS

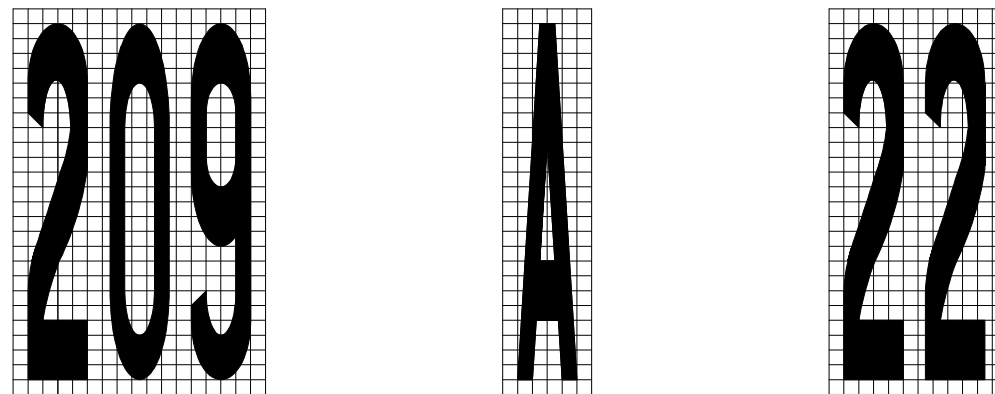

MESSAGE SIZE AND SPACING

NOTES:

1. Messages shall meet requirements of Specification Section 971-7 and Section 711.
2. The thickness of the preformed message shall be 125 mils.
3. The message shall consist of white letters and numbers with black contrasting material. The black material shall meet the mat dimensions shown and have a minimum skid resistance value of 55 BPN.
4. The "EXIT NUMBER" position remains the same (117'-8") from the beginning of taper regardless of the number of lines of information.

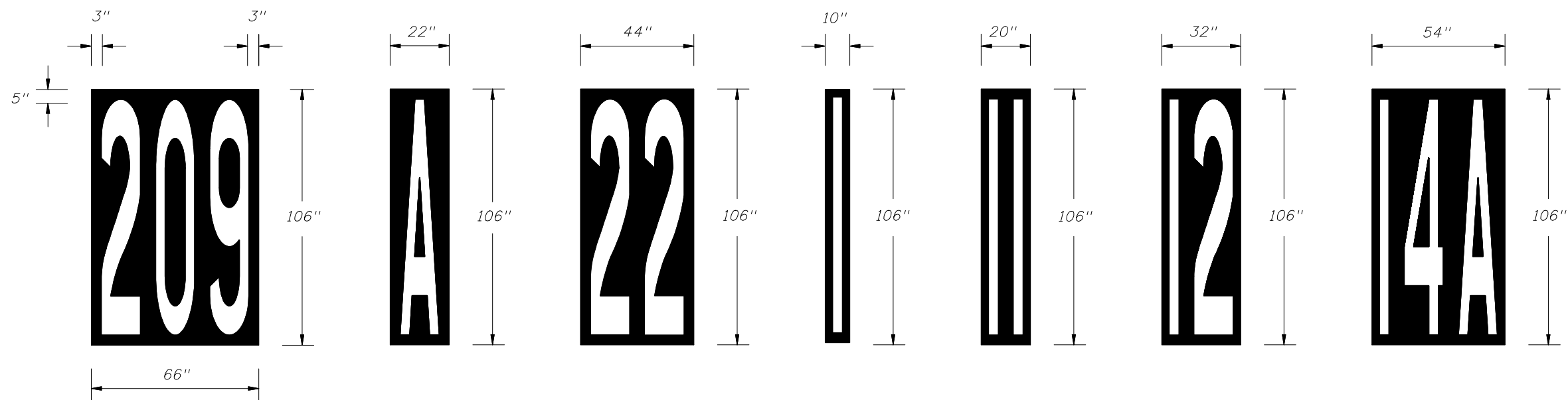

MAT DIMENSIONS



Stop Bar Perpendicular To Edge Of Travelway Or 8' From & Parallel To Gate When Present.

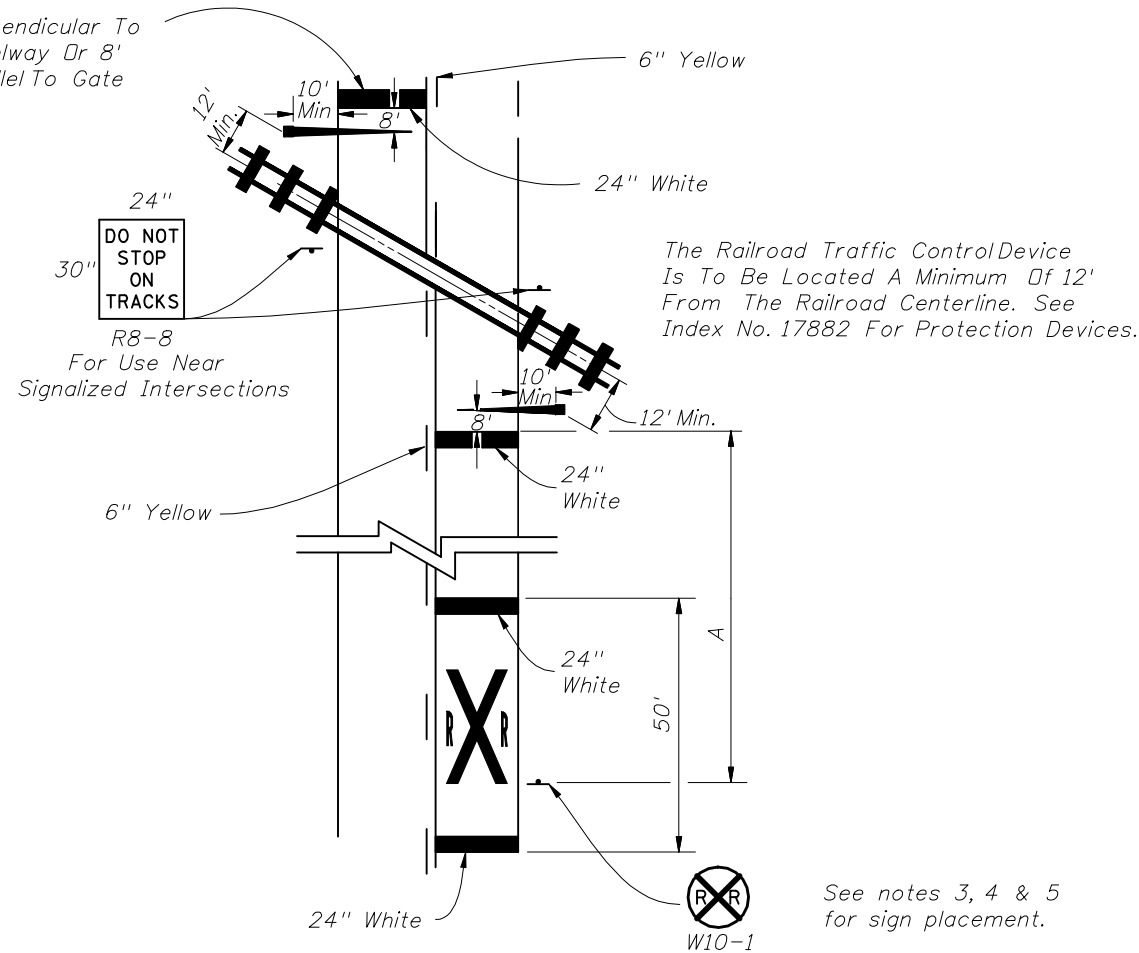

RAILROAD CROSSING AT 2-LANE ROADWAY

Stop Bar Perpendicular To Edge Of Travelway Or 8' From & Parallel To Gate When Present

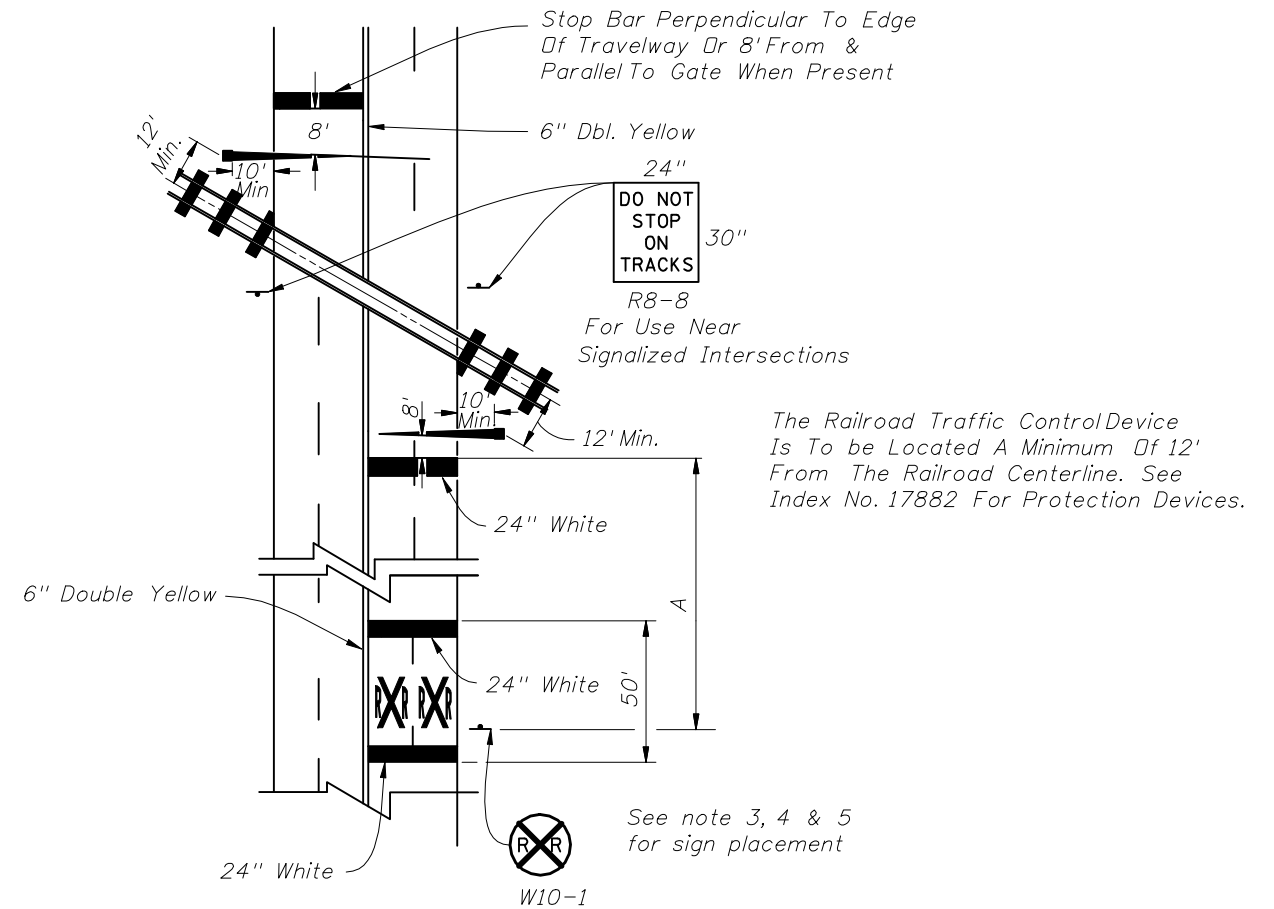

RAILROAD CROSSING AT 4-LANE ROADWAY

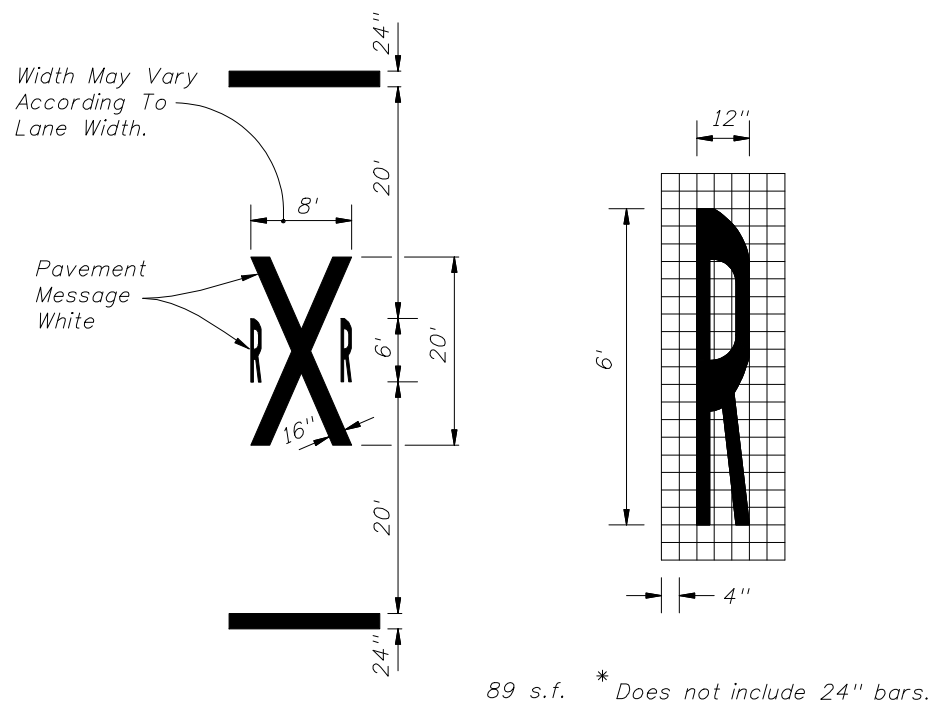

TYPICAL PAVEMENT MARKINGS FOR R/R CROSSING

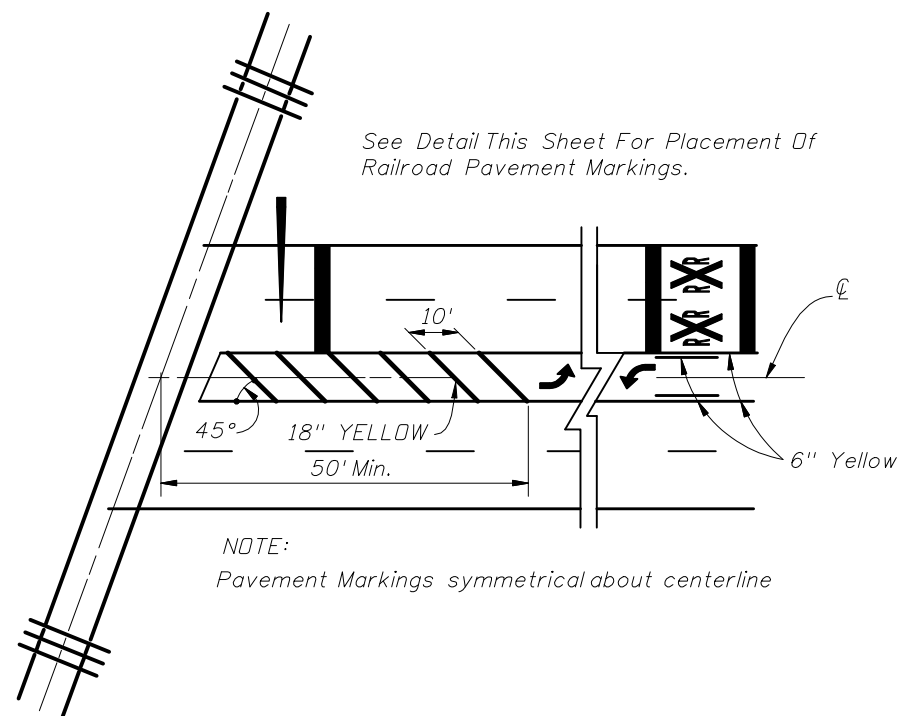

PAVEMENT MARKINGS FOR TERMINATION OF TWO WAY LEFT TURN AT R/R CROSSINGS

NOTES:

1. When computing pavement messages, quantities do not include transverse lines.
2. When dynamic devices are not present or are to be installed, the crossbuck shall be located at the future location of the RR gate or signal and gate in accordance with Index No. 17882.
3. Placement of sign W10-1 in a residential or business district, where low speeds are prevalent, the W10-1 sign may be placed a minimum distance of 100' from the crossing. Where street intersections occur between the RR pavement message and the tracks an additional W10-1 sign & additional Pavement message should be used.
4. Recommended location for FTP-61-06 or FTP-62-06 sign, 100' urban & 300' rural in advance of the crossings.
5. A portion of the pavement marking symbol should be directly opposite the W10-1 sign.

SPEED MPH	" A " IN FT.
60	400
55	325
50	250
45	175
40	125
35	100
URBAN	85 MIN.



2010 FDOT Design Standards

SPECIAL MARKING AREAS

Last Revision 07/01/09 Sheet No. 8 of 14

Index No. 17346

GENERAL NOTES

1. For traffic and pedestrian signal installation, refer to Index No. 17721 through 17890.
2. For public sidewalk curb ramps, refer to Index No. 304.
3. For pavement marking and sign installation, refer to Indexes 11200 through 17356.
4. Crosswalk minimum widths: Intersection Crosswalk 6'.
Midblock Crosswalk 10'.
5. All crosswalk markings shall be white.
6. Longitudinal lines in Special Emphasis Crosswalk shall be 24" wide and spaced to avoid the wheelpath of vehicles as shown in detail. The maximum space between markings shall not exceed 60". A longitudinal marking shall be centered at each lane line. Additional longitudinal markings shall be placed at the center of each lane (1/2W).

Where the Crosswalk is skewed to the lane lane lines, the Special Emphasis longitudinal lines should be parallel to the lane line.

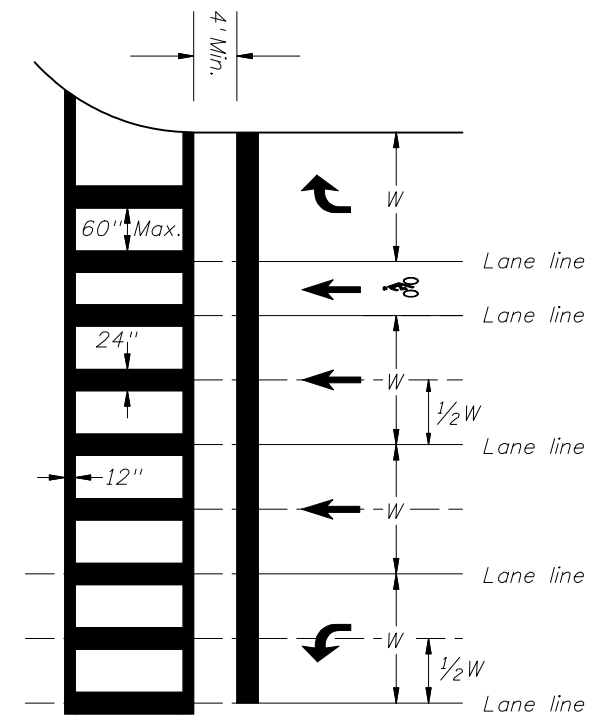
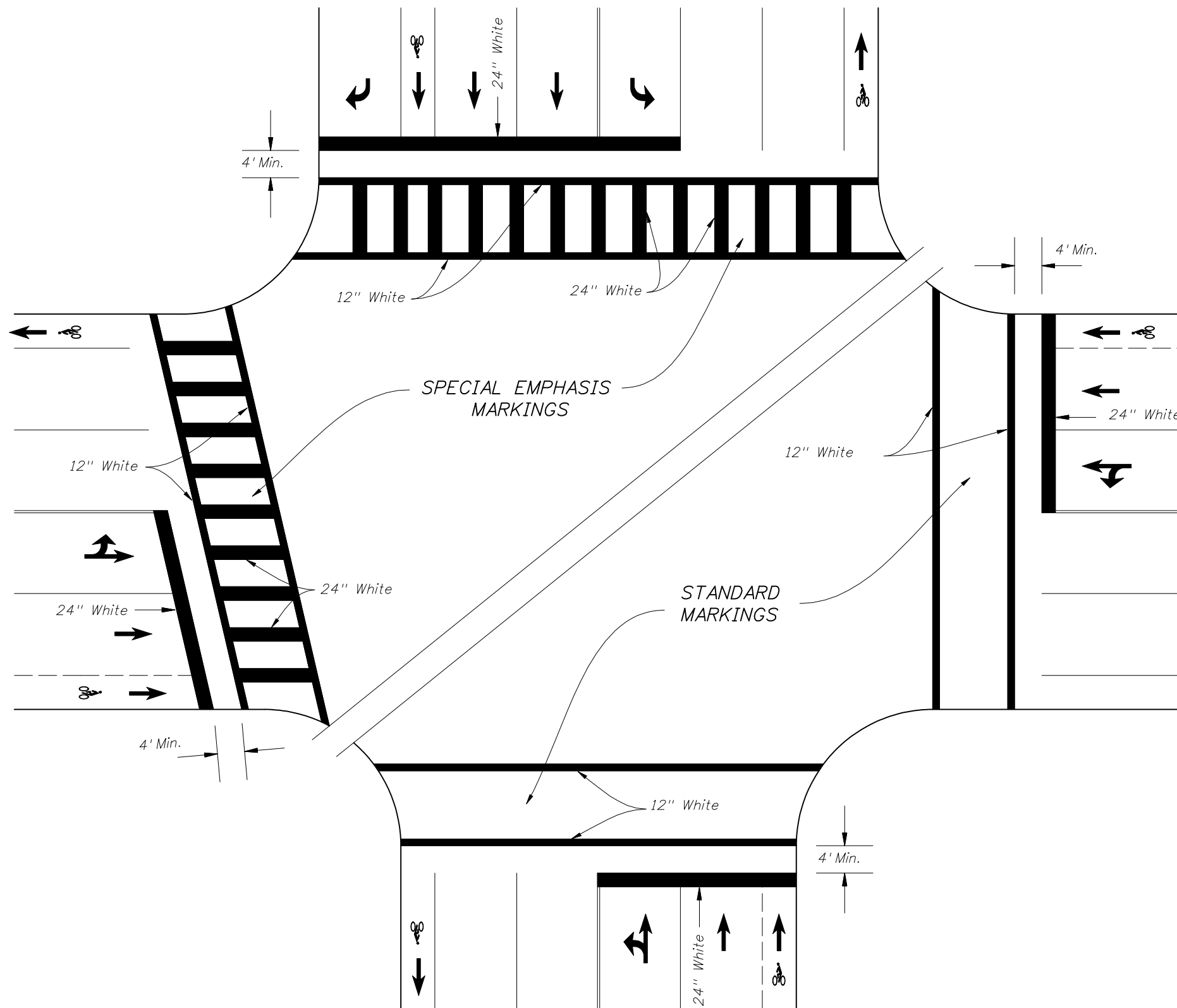

SPECIAL EMPHASIS CROSSWALK MARKING DETAIL

SPECIAL EMPHASIS AND STANDARD CROSSWALKS SIGNALIZED OR STOP SIGN CONTROLLED INTERSECTION



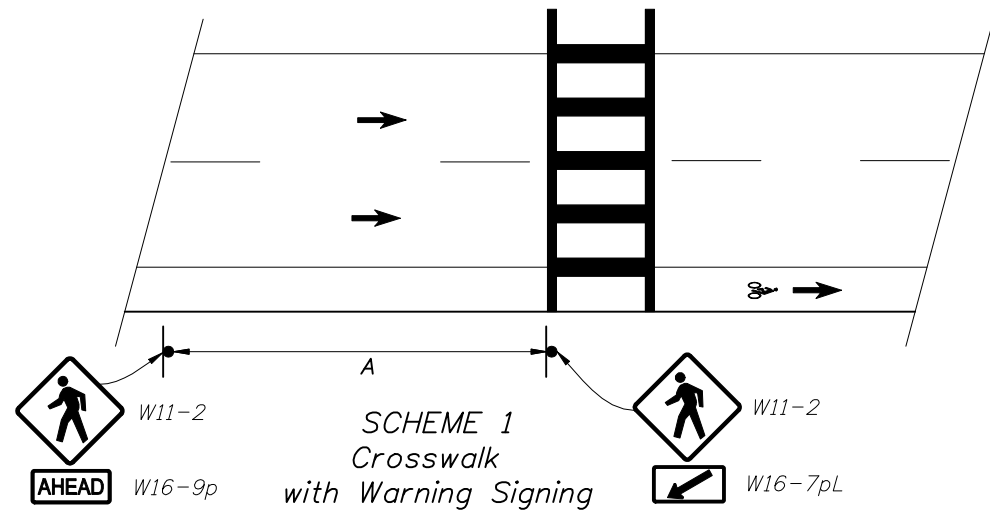

SCHEME 1
Crosswalk
with Warning Signing

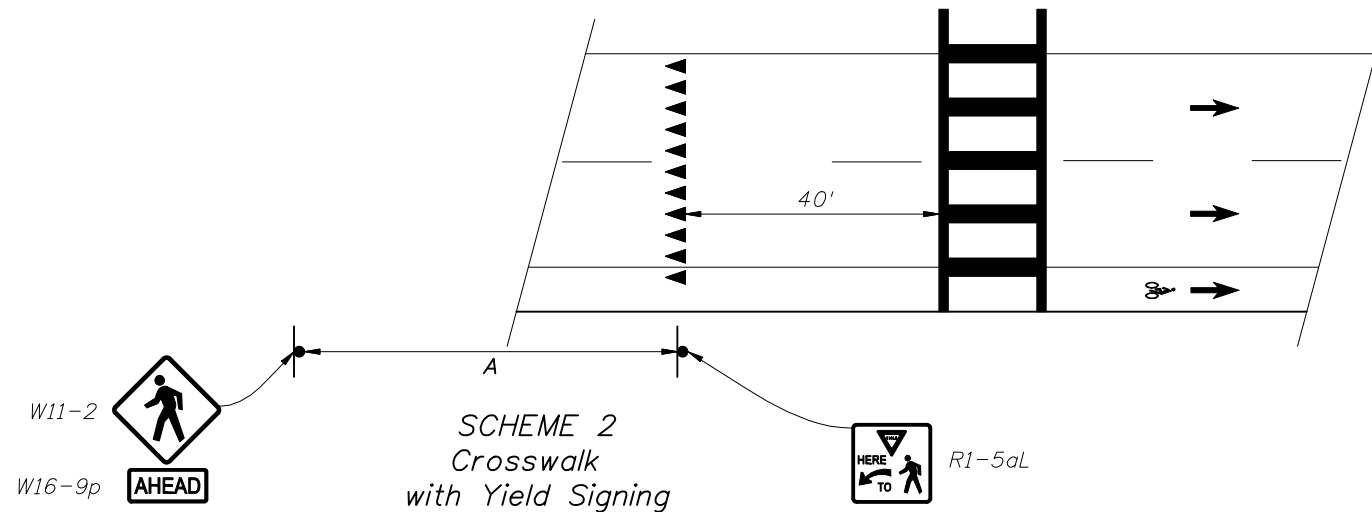

SCHEME 2
Crosswalk
with Yield Signing

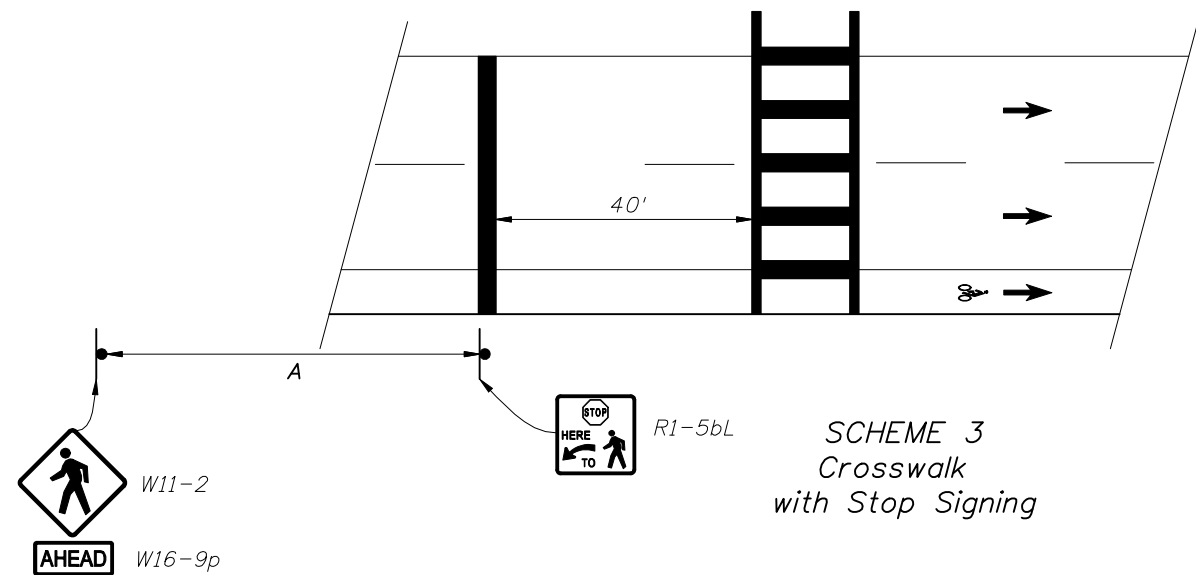

SCHEME 3
Crosswalk
with Stop Signing

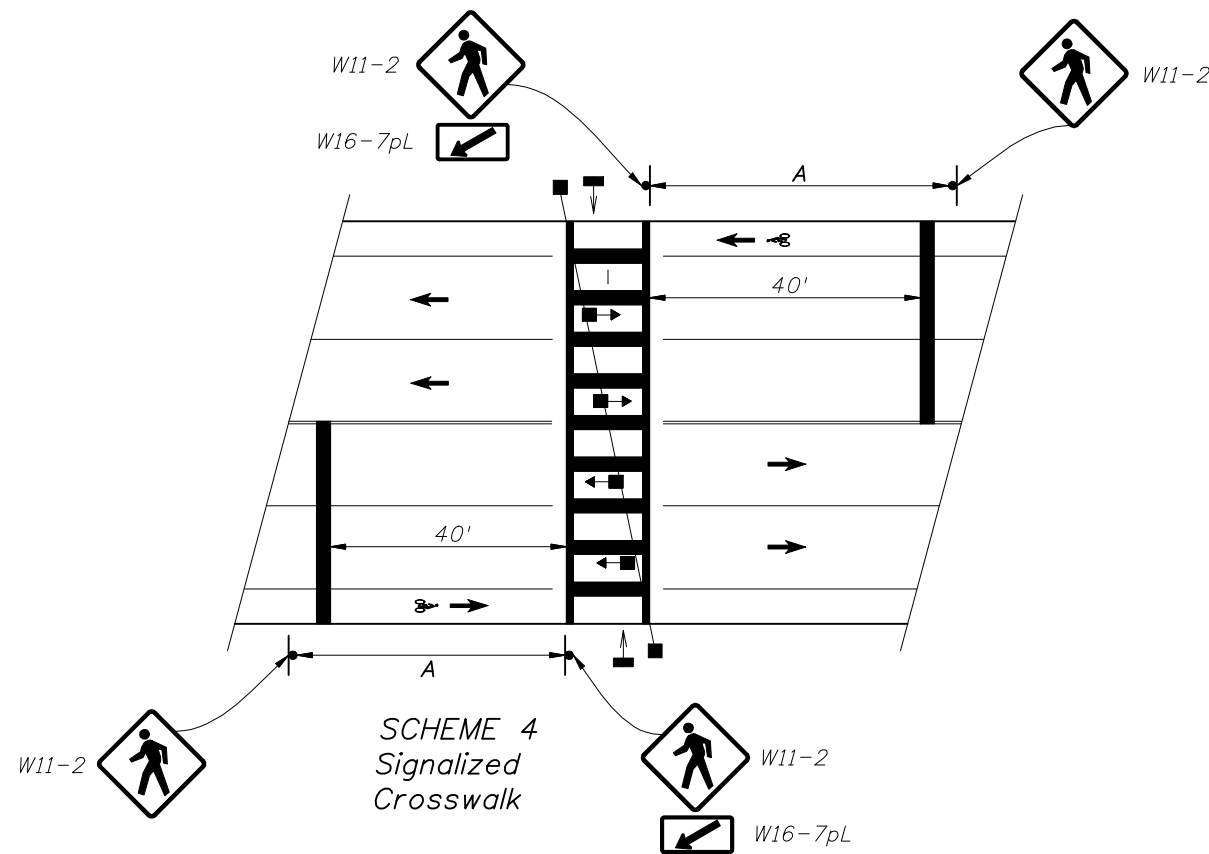

SCHEME 4
Signalized
Crosswalk

APPROACH SPEED MPH	A-SUGGESTED DISTANCE (Ft.)
25 Or Less	200
26 To 35	250
36 To 45	300
46 To 55	325

- Plans shall indicate which crosswalk scheme is to be used.
- The details shown do not depict the signing and markings for multi-lane roadways with divided medians. For these applications, additional signs shall be installed on the median side.
- All mid-block crosswalks shall use high emphasis crosswalk markings.
- Crosswalk marking should utilize preformed marking materials.



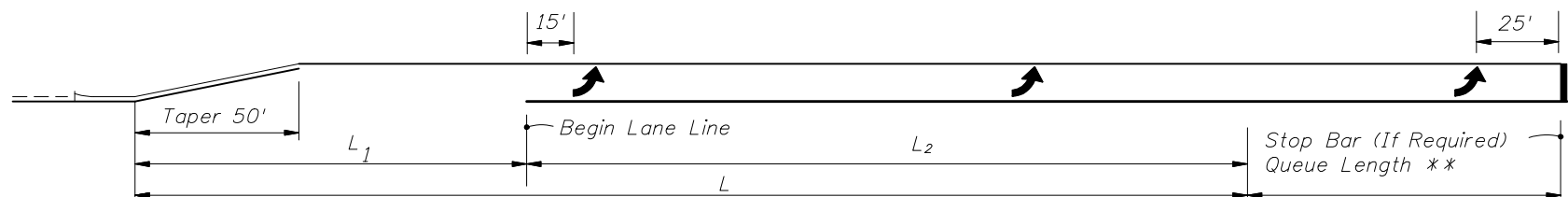

SINGLE LEFT TURNS

** Queue Length Is Measured From The Median Nose Radial Point Or, When A Stop Bar Is Required, From The Stop Bar.

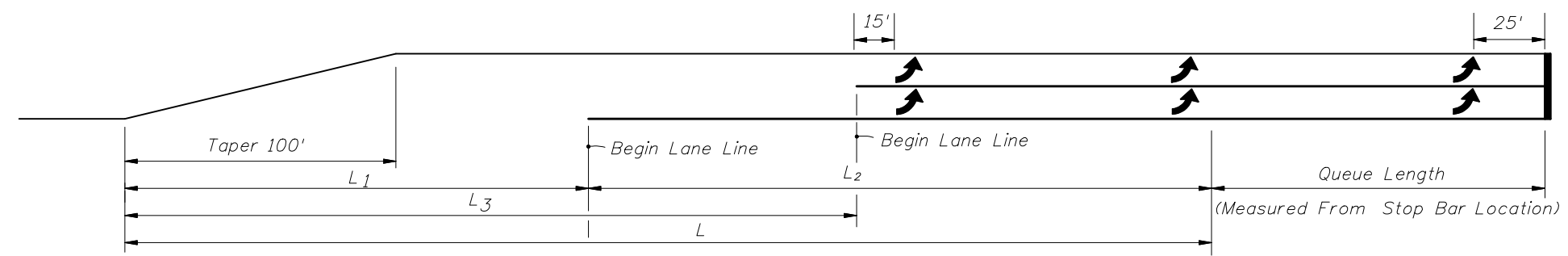

DOUBLE LEFT TURNS

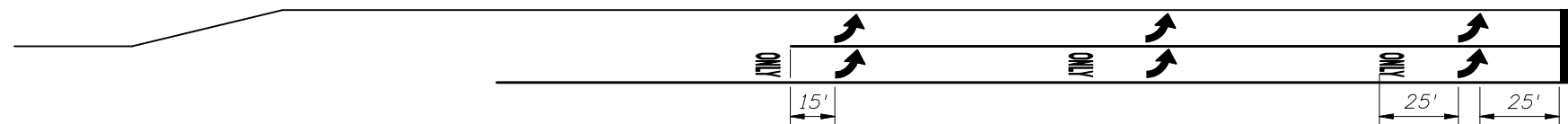

The ONLY pavement message is required for turn lanes, where the thru lane becomes turn lane.

Through Lane Becomes Exclusive Left Turn

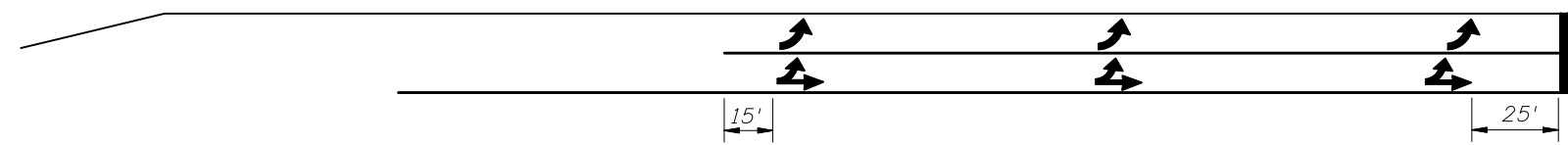

Through Lane Becomes Optional Left Turn

DOUBLE LEFT TURN MARKINGS

TURN LANES • CURBED AND UNCURBED MEDIANS							
Design Speed (mph)	Clearance Distance L_1	URBAN CONDITIONS			RURAL CONDITIONS		
		Brake To Stop Distance L_2	Total Decel. Distance L	Clearance Distance L_3	Brake To Stop Distance L_2	Total Decel. Distance L	Clearance Distance L_3
35	70'	75'	145'	110'	---	---	---
40	80'	75'	155'	120'	---	---	---
45	85'	100'	185'	135'	---	---	---
50	105'	135'	240'	160'	185'	290'	160'
55	125'	---	---	---	225'	350'	195'
60	145'	---	---	---	260'	405'	230'
65	170'	---	---	---	290'	460'	270'

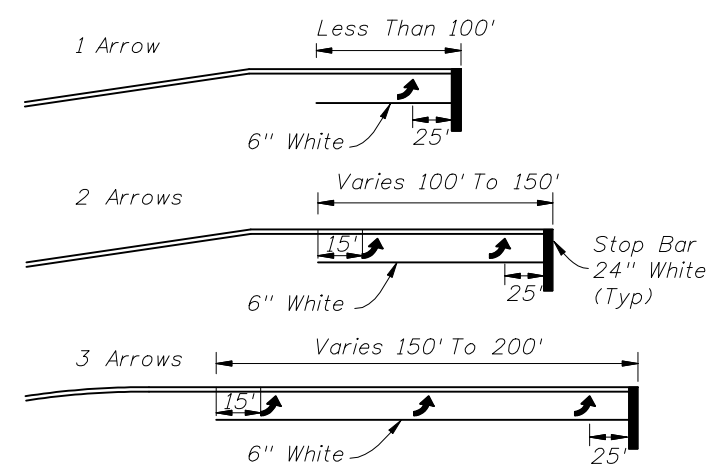

Arrow should be evenly spaced between first and last arrow. Turn lanes longer than 200' add one arrow for each 100' additional length.

ARROW SPACING

NOTES:

1. The "Begin Lane Line" locations are based on the standard lengths shown in Design Standard 301. These locations must be adjusted on a case by case basis for turn lanes not meeting the standard lengths.
2. Yellow left turn edge marking may be used adjacent to raised curb or grass medians if lane use is not readily apparent to drivers approaching a left turn storage lane.
3. Refer to Design Standard Index 301 for Roadway Details.
4. This Index also applies to right turn lanes.



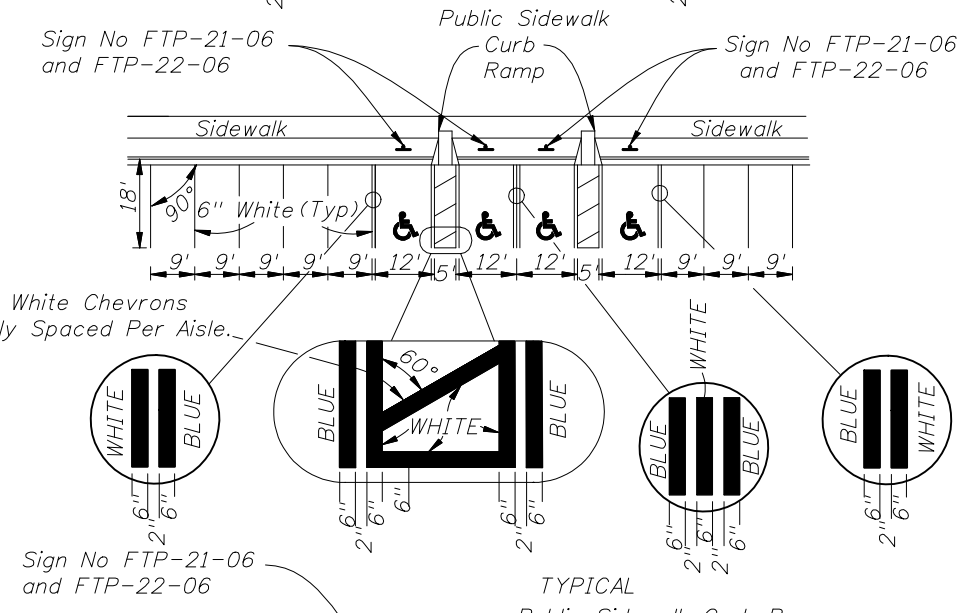
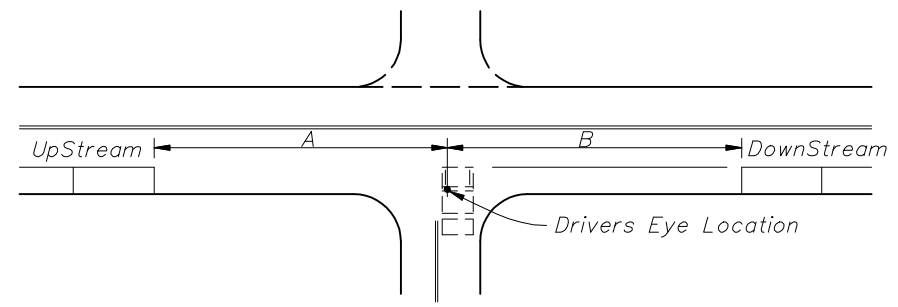
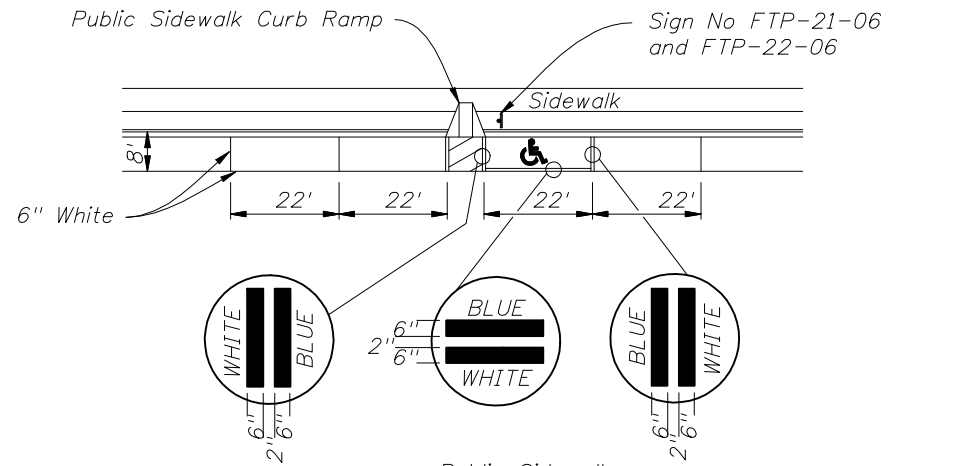

SPEED MPH	UP STREAM (A)	DOWN STREAM (B)	
		2 LANE	4 LANE
0-30	85'	60'	45'
35	100'	70'	50'

- NOTES**
- Distances measured longitudinally along the street from driver location of entering vehicle to end of parking restriction.
 - Distances applicable to intersecting street, major driveways and other driveways to the extent practical.
 - For nonsignalized intersections, the values above shall be compared with the values for signalized intersections and the maximum restrictions implemented. These restrictions apply to both accessible and nonaccessible parking.

MINIMUM PARKING RESTRICTION FOR NONSIGNALIZED INTERSECTIONS

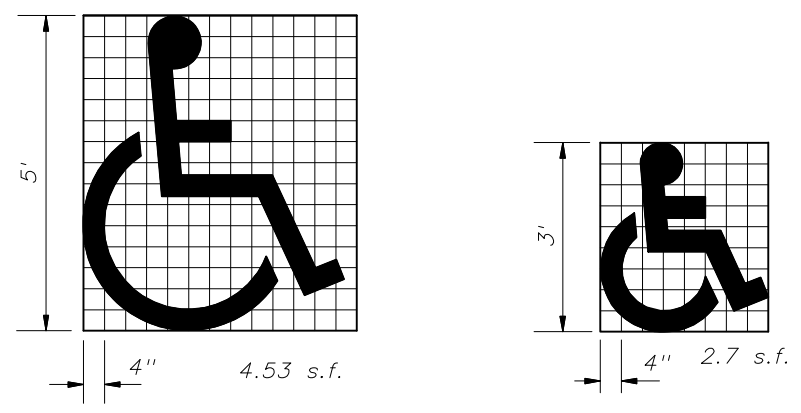

Use of pavement symbol in accessible parking spaces is optional, when used the symbol shall be 3' or 5' high and white in color.

UNIVERSAL SYMBOL OF ACCESSIBILITY

GENERAL NOTES (Signalized & Nonsignalized)

- For entrances to a one-way street, the downstream restriction may be reduced to 20'.
- Parking shall not be allowed within 20' of a crosswalk.
- All parking lane markings shall be 6" white.
- Parking lane lines shall be broken at driveways.
- Refer to Chapter 316, Fla. Statutes, for laws governing parking spaces.
- Where curb and gutter is used, the gutter pan width may be included as part of the minimum width of parking lane, but desirably the lane width should be in addition to that of the gutter pan.

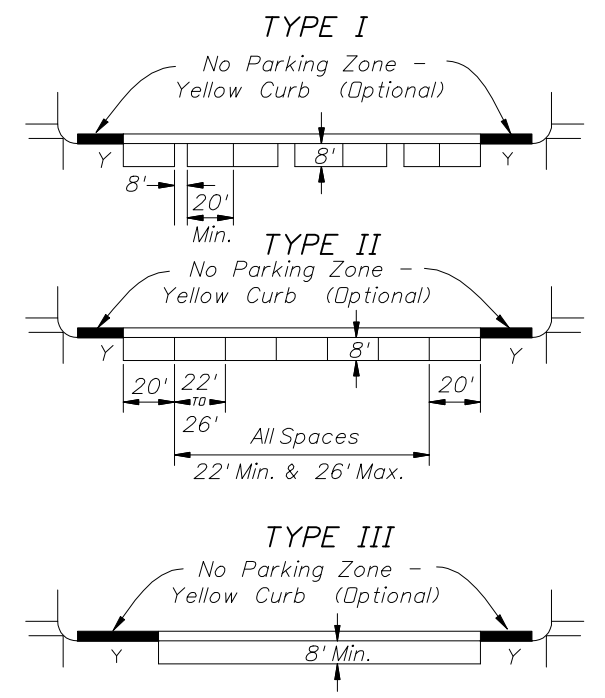

SPEED LIMIT MPH	SIGNALIZED INTERSECTIONS	DISTANCE FROM CURB RADIUS (Y)
0-30	30'	
35	50'	

PARKING RESTRICTION (FT.) FOR SIGNALIZED INTERSECTION

- NOTES:**
- Parking restrictions measured from curb radius point.
 - Restrictions for accessible parking are the same as those applied to nonsignalized intersections.

MINIMUM PARKING RESTRICTION FOR SIGNALIZED INTERSECTION

- NOTES:**
- Dimensions are to the centerline of markings.
 - An Access Aisle is required for each accessible space when angle parking is used.
 - Criteria for pavement markings only, not public sidewalk curb ramp locations. For ramp locations refer to plans.
 - Blue pavement markings shall be tinted to match shade 15180 of Federal Standards 595a.
 - The FTP-22-06 panel shall be mounted below the FTP-21-06 sign.

PAVEMENT MARKING FOR PUBLIC SIDEWALK CURB RAMP IN REST AREAS

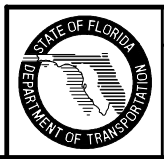

2010 FDOT Design Standards

SPECIAL MARKING AREAS (PARKING)

Last Revision	Sheet No.
07/01/09	12 of 14
Index No.	
17346	

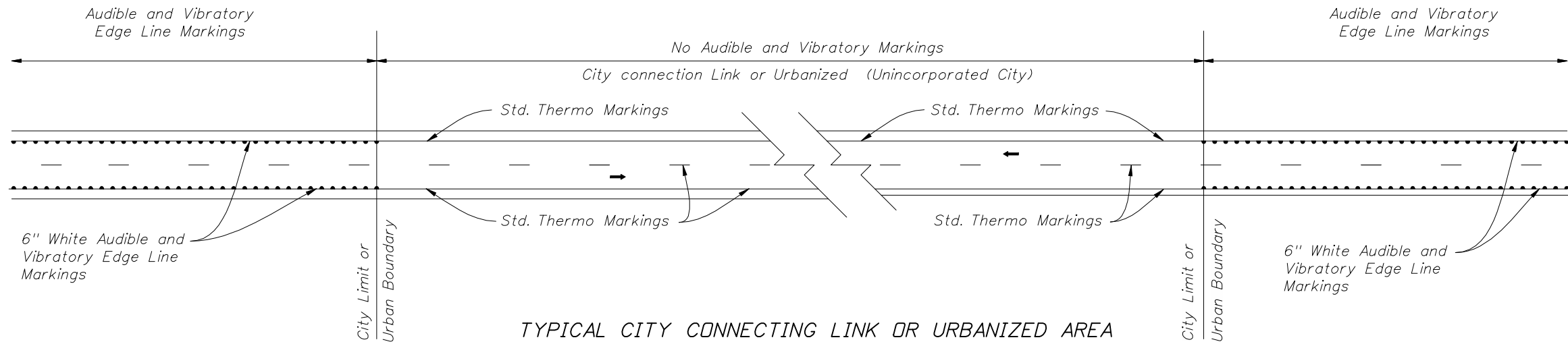

TYPICAL CITY CONNECTING LINK OR URBANIZED AREA

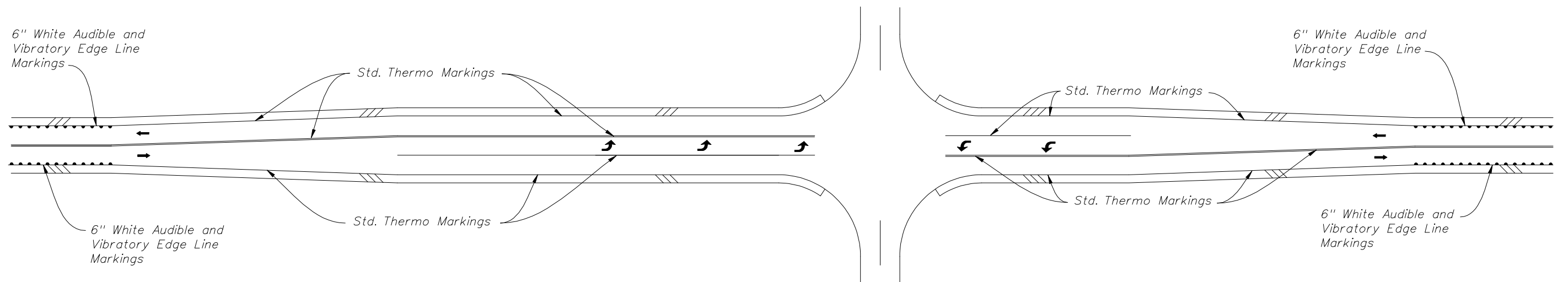

TYPICAL RURAL INTERSECTION WITH TURN LANES

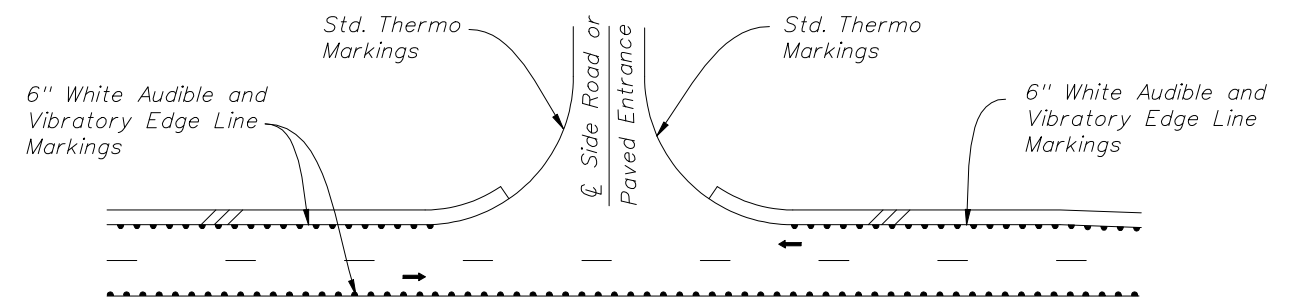
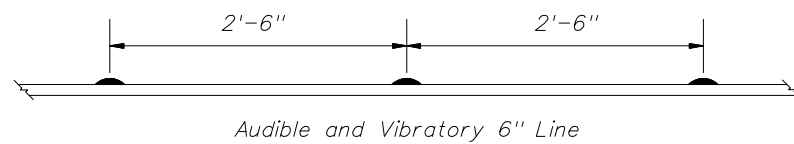

TYPICAL RURAL INTERSECTION WITHOUT TURN LANES

AUDIBLE AND VIBRATORY MARKINGS

2 LANE ROADWAYS

	2010 FDOT Design Standards	Last Revision 07/01/09	Sheet No. 13 of 14
	SPECIAL MARKING AREAS		Index No. 17346

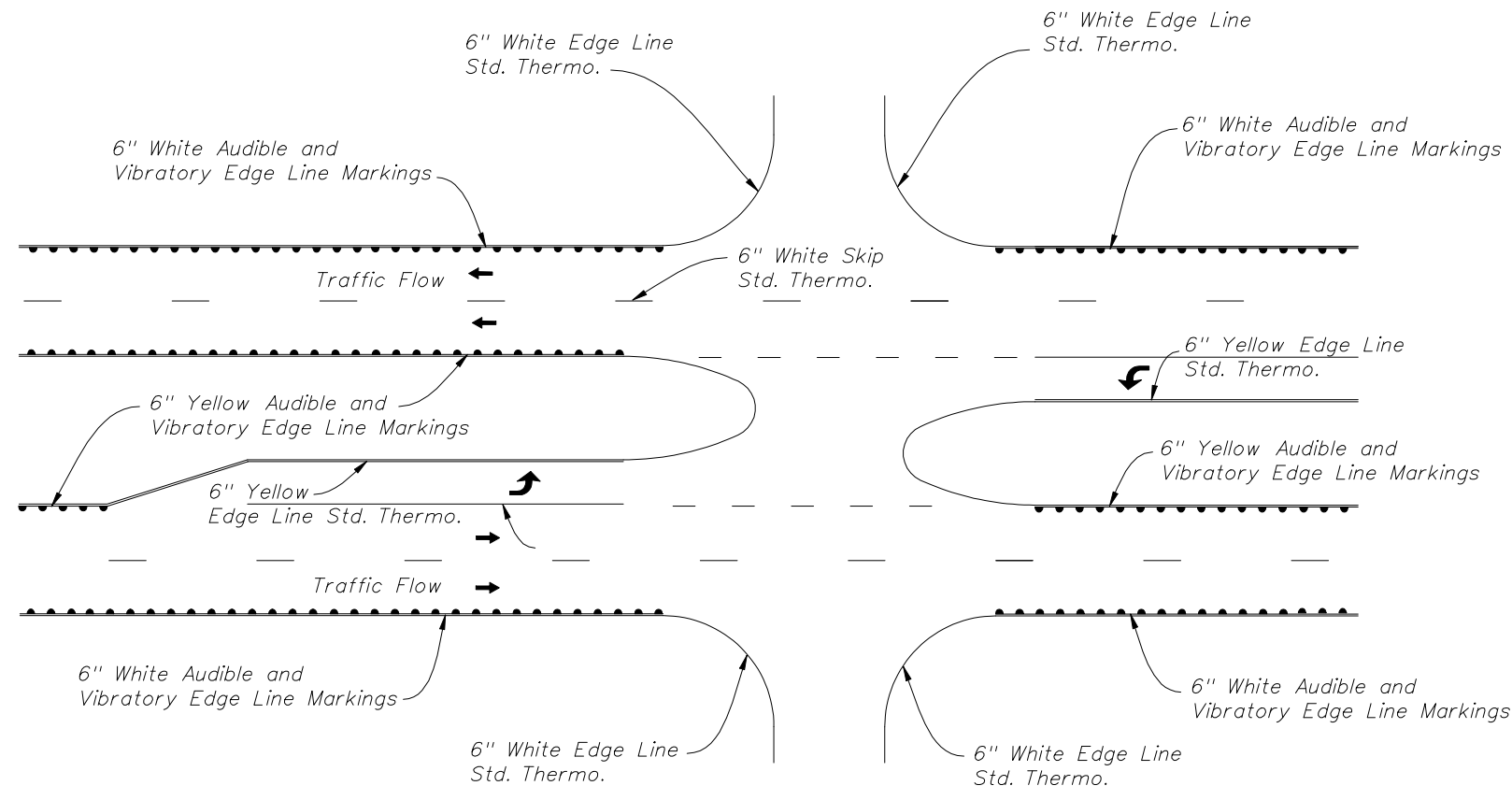

1. The Contractor Shall Adjust The Maintenance Of Traffic During Installation To Provide Sufficient Time For The Markings To Bear Traffic.
2. The Height Of The Transverse Bar For Markings Shall Be 0.45 To 0.55 Inches Above The Pavement Surface At The Edge Of The Marking.
3. Transverse Bars Shall Be Evenly Space In The Marking At Intervals Of 30 Inches Center To Center.
4. The Transverse Bar May Have A Drainage Channel On Each Bar. The Width Of The Drainage Channel May Not Exceed 0.25 Inches At The Bottom Of The Channel.
5. Audible And Vibratory Markings Shall Only Be Installed On Centerline Markings Of Two Lane Roads When Shown In The Plans.
6. When Raised Pavement Markers Conflict With The Installation Of The Centerline Markings, The Contractor Shall Be Responsible For Removing And Replacing The Raised Pavement Markings. The Additional Expenses Associated With The Raised Pavement Markings Shall Be Included In The Cost Of The Marking.
7. Grinding Is An Acceptable Method Of Removal Of The Existing Markings Where Markings Are Installed As Replacement Markings.
8. The Specifications Allow The Audible Markings To Utilize A Flat Base Line Or An Inverted Rib Profile Base Line.

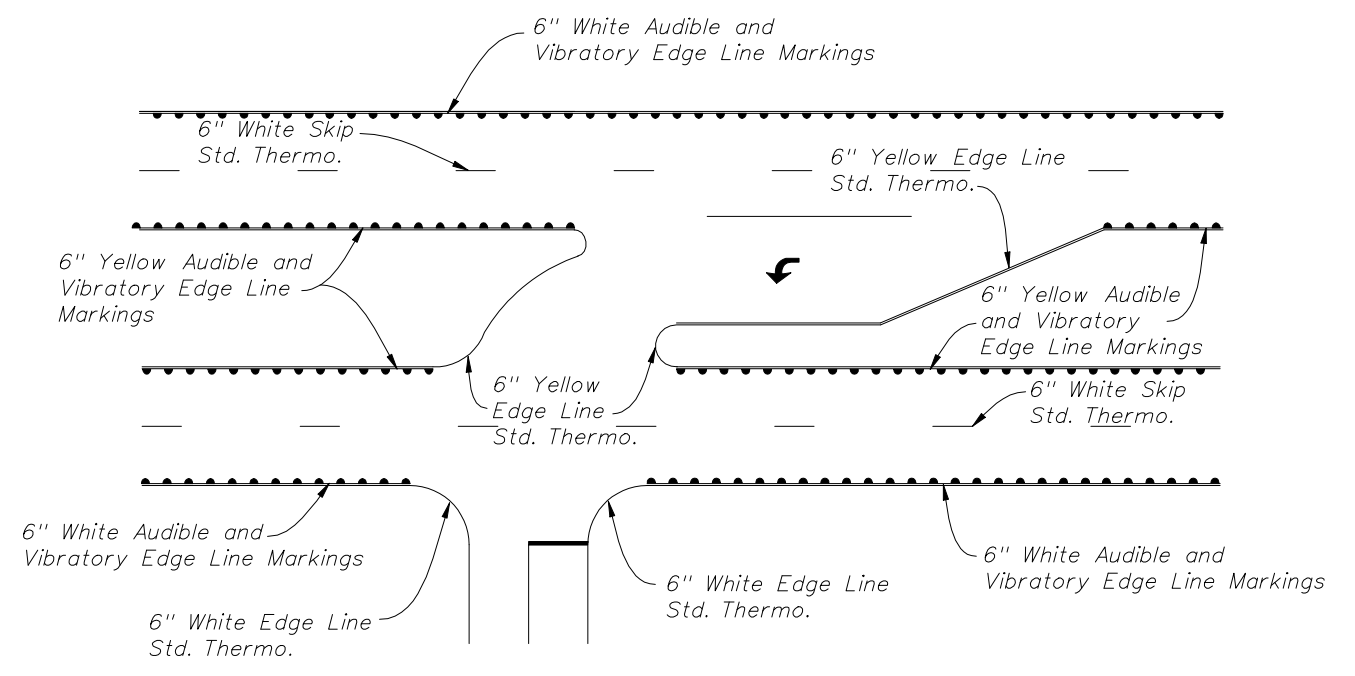
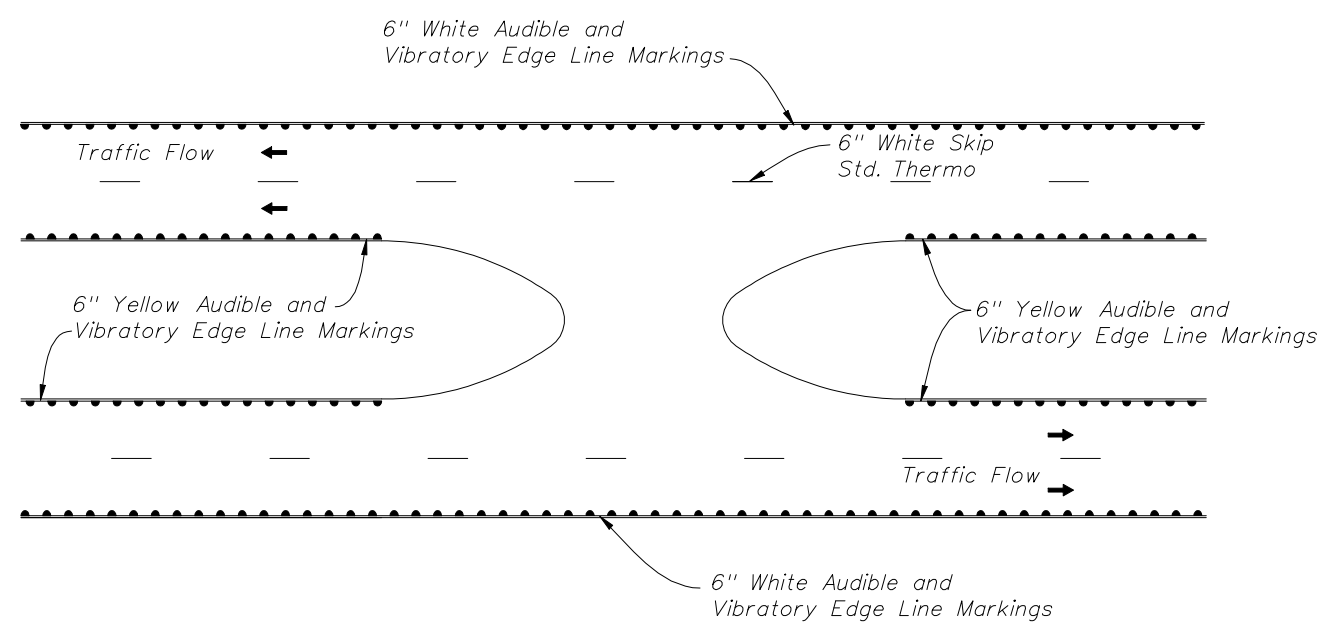

AUDIBLE AND VIBRATORY MARKINGS

MULTI-LANE ROADWAYS

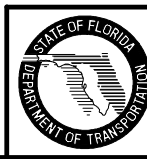

2010 FDOT Design Standards

SPECIAL MARKING AREAS

Last Revision	Sheet No.
07/01/09	14 of 14
Index No.	
17346	

1. Recommended spacing of symbols: Immediately after intersections and major driveways and at a maximum spacing of 600 feet for urban sections and 1320 feet for rural sections.

2. All pavement markings and pavement messages shall be white.

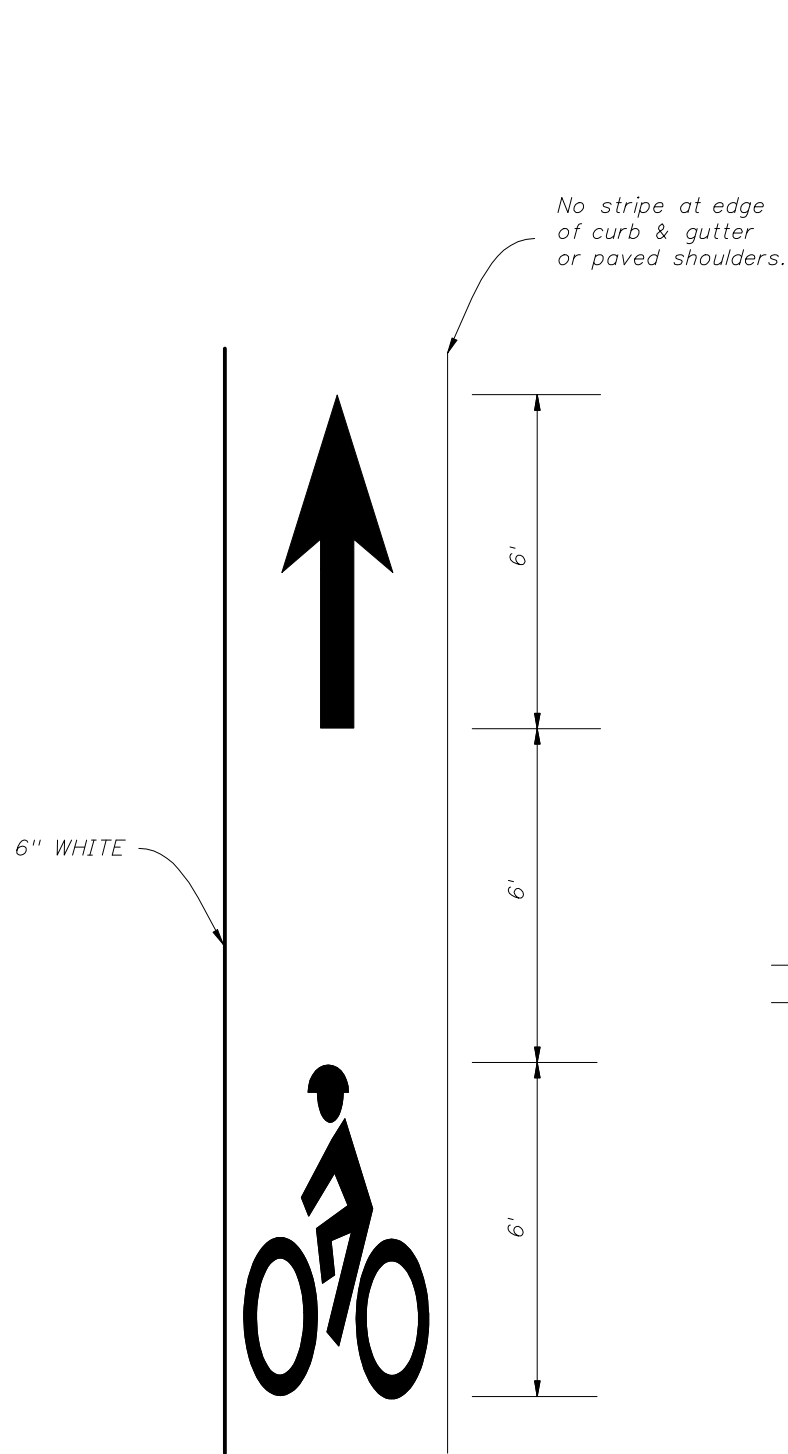

DETAIL OF BIKE LANE MARKINGS

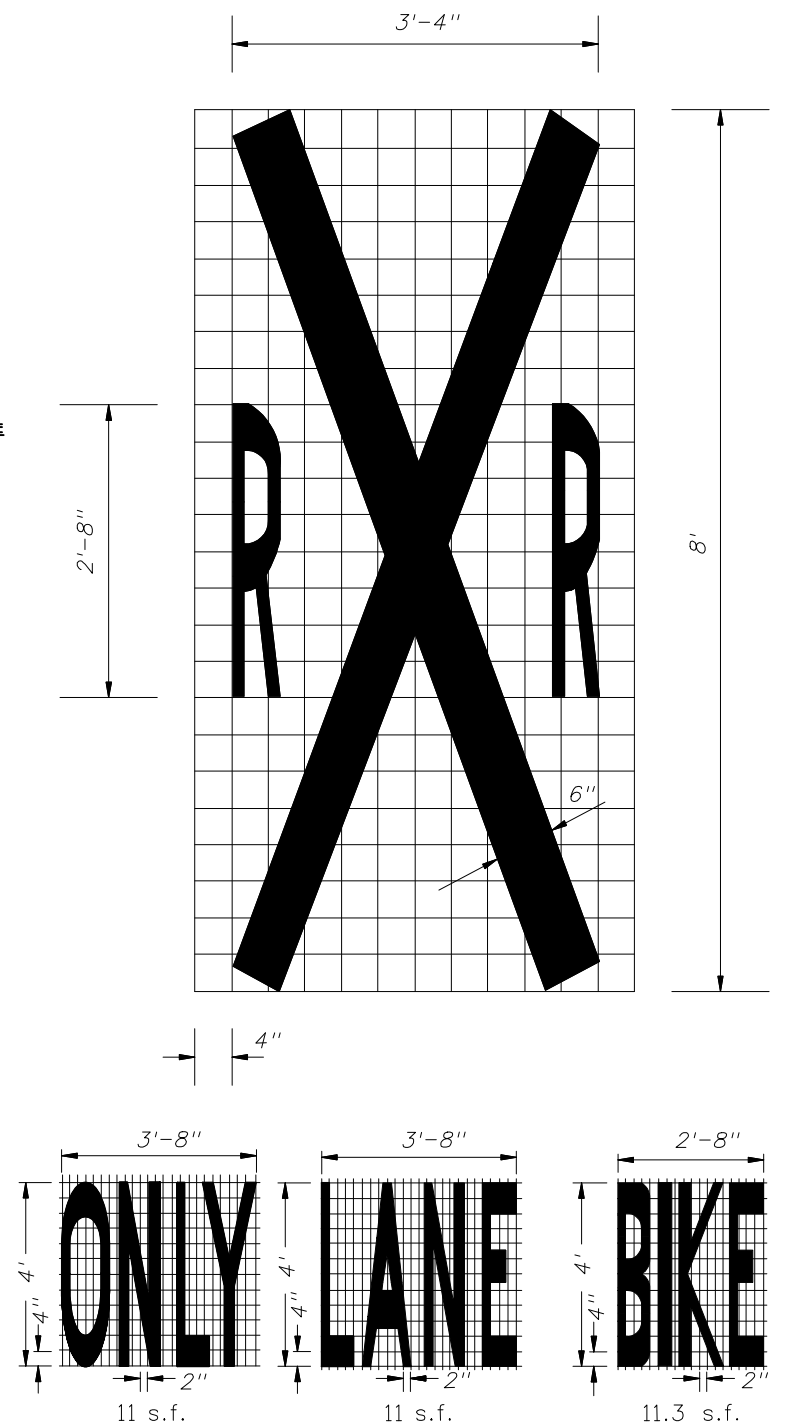
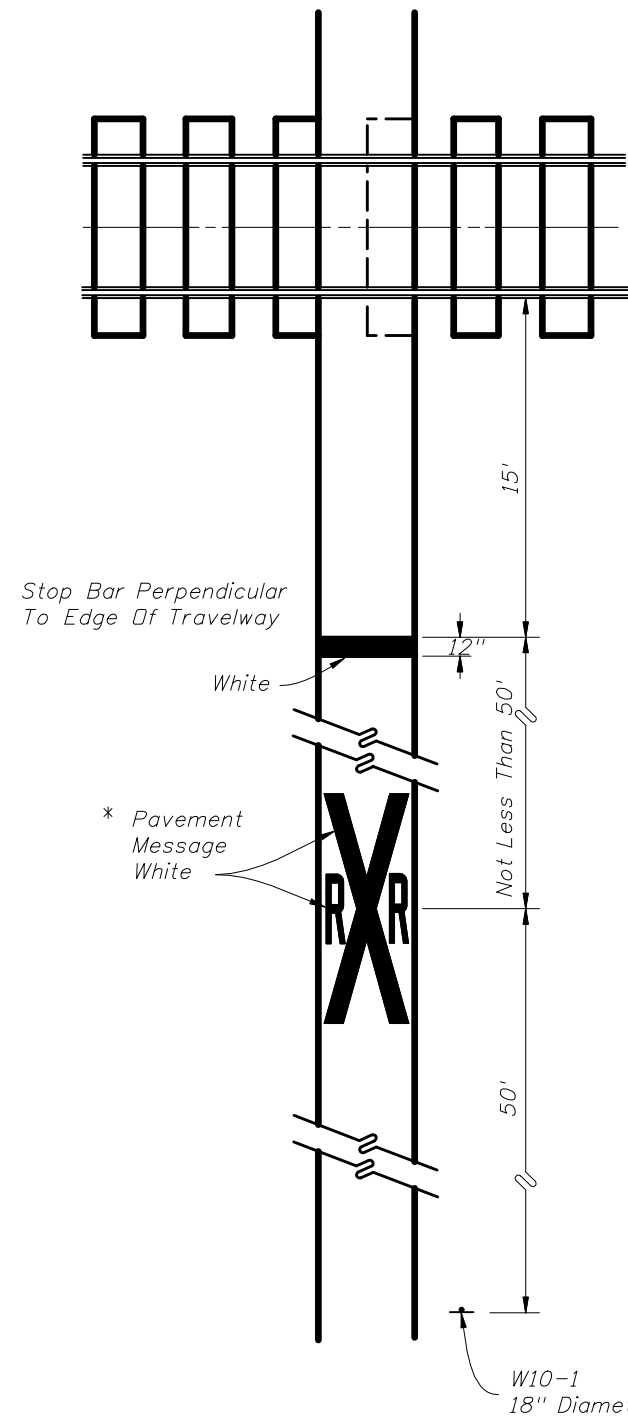
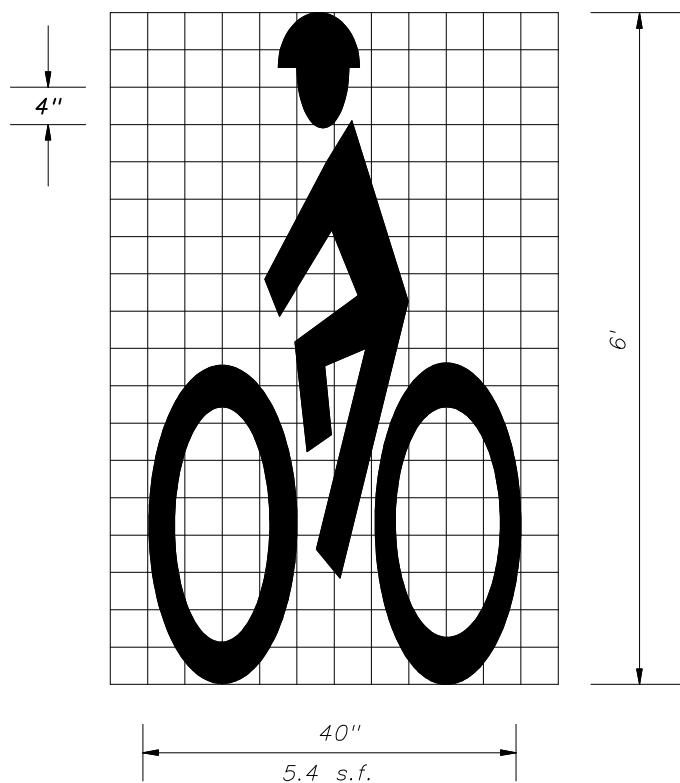
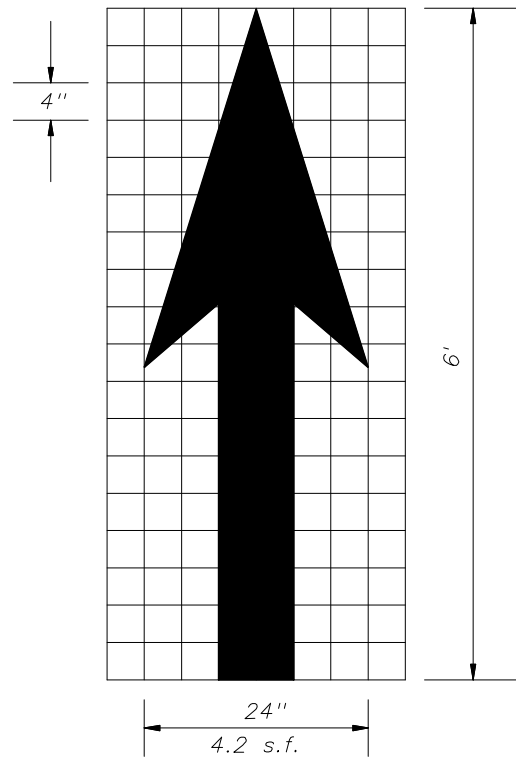

PAVEMENT MESSAGE DETAILS

* NOTE

3. When used on a bike lane (adjacent to vehicle lane) markings shall be placed adjacent to markings for vehicles & W10-1 sign shall be sized and placed for vehicles.

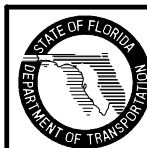

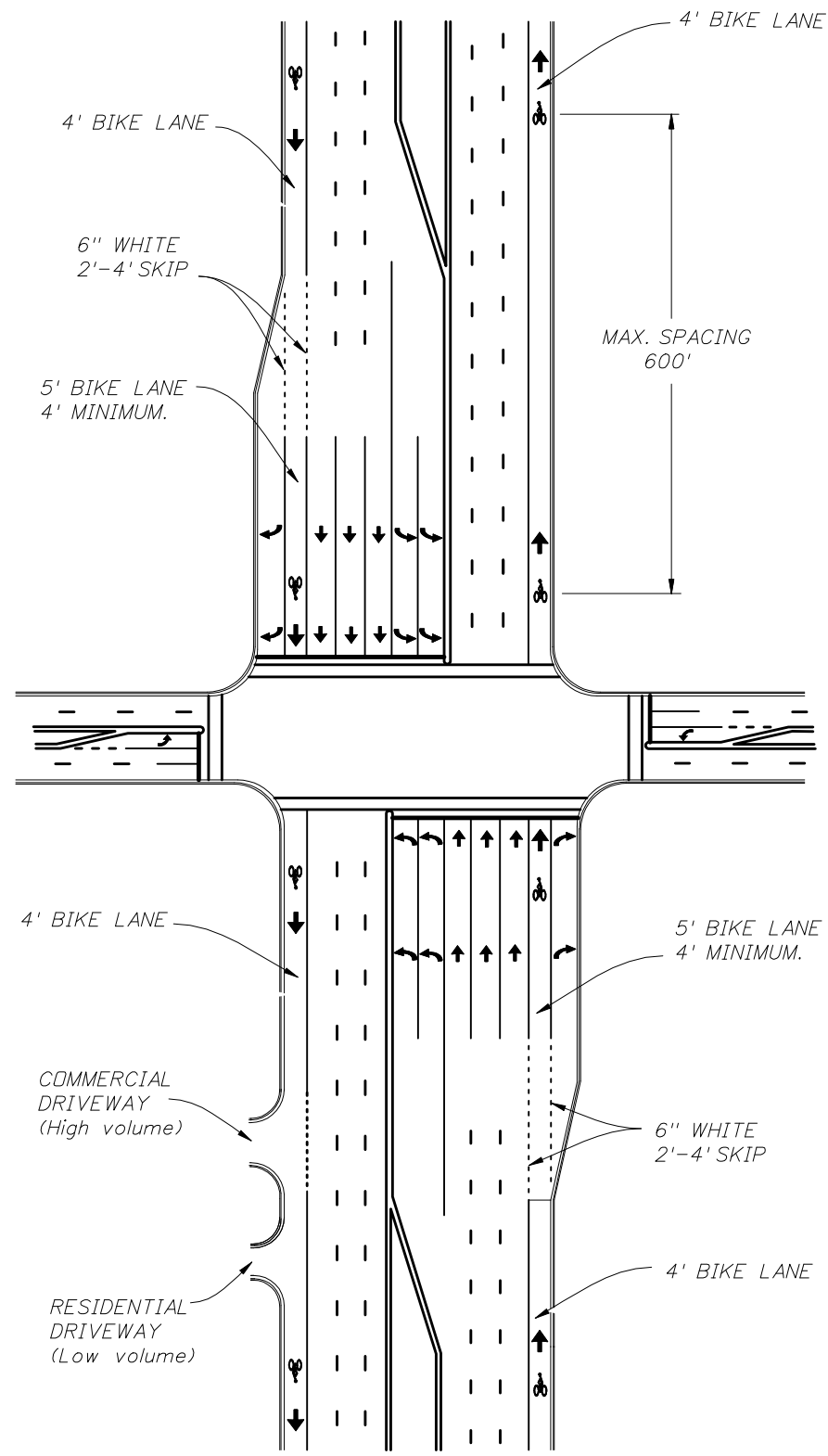

MAJOR INTERSECTION WITH SEPARATE RIGHT TURN LANE URBAN TYPICAL SECTION (CURB AND GUTTER)

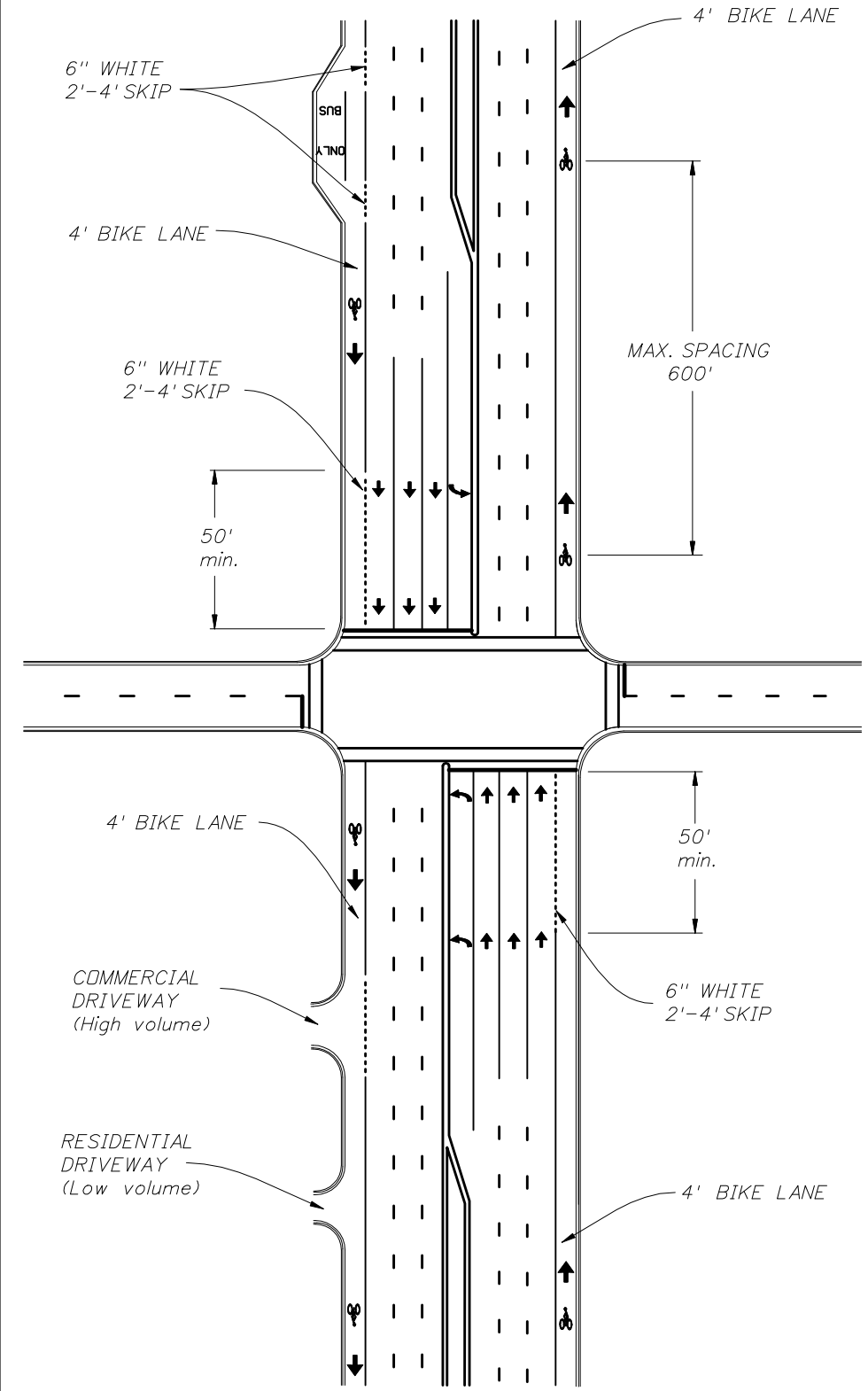

MAJOR INTERSECTION, NO RIGHT TURN LANE PLUS BUSBAY URBAN TYPICAL SECTION (CURB AND GUTTER)

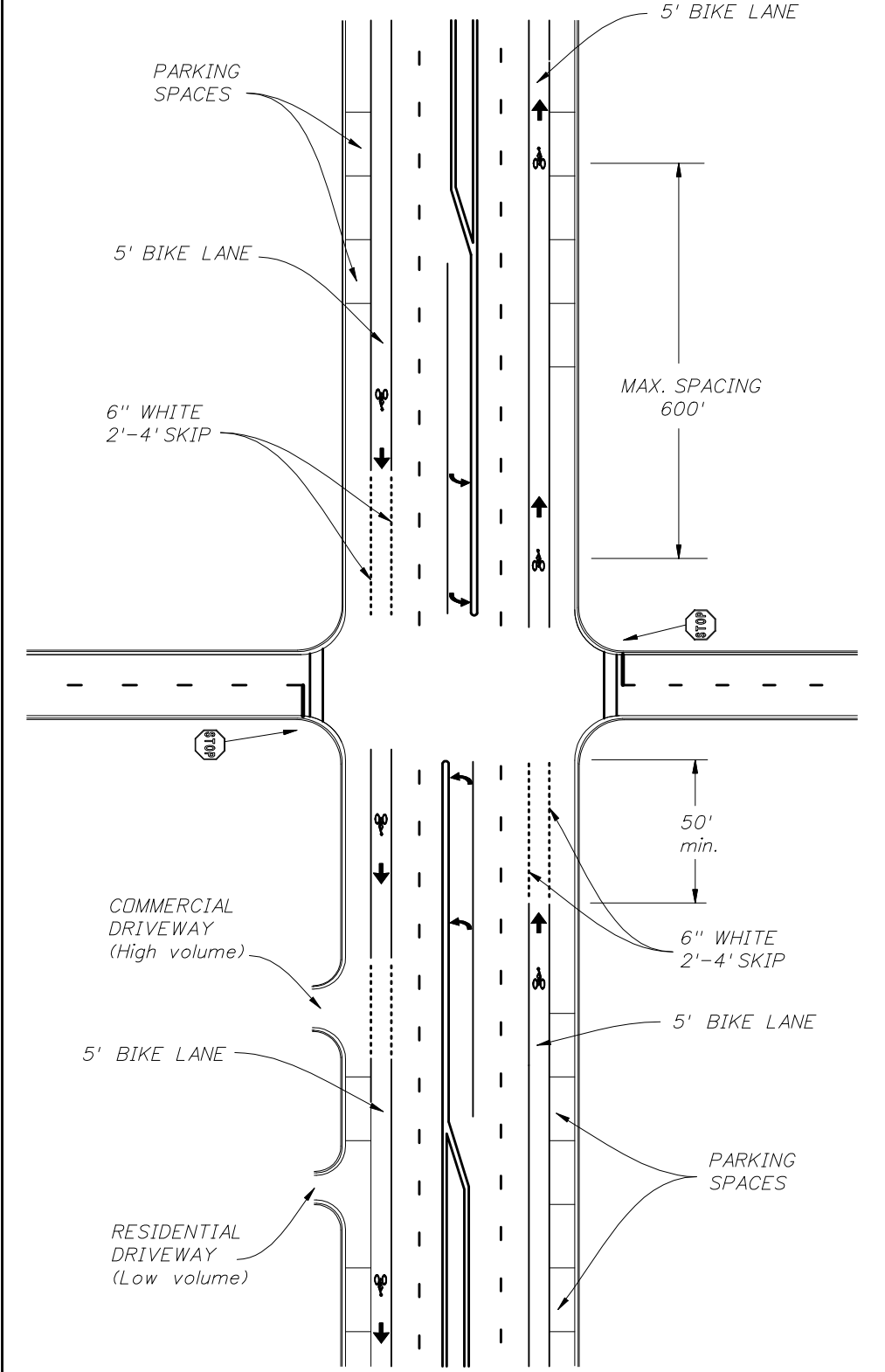

MAJOR WITH LOCAL STREET INTERSECTION, NO RIGHT TURN LANE, ON STREET PARKING URBAN TYPICAL SECTION (CURB AND GUTTER)



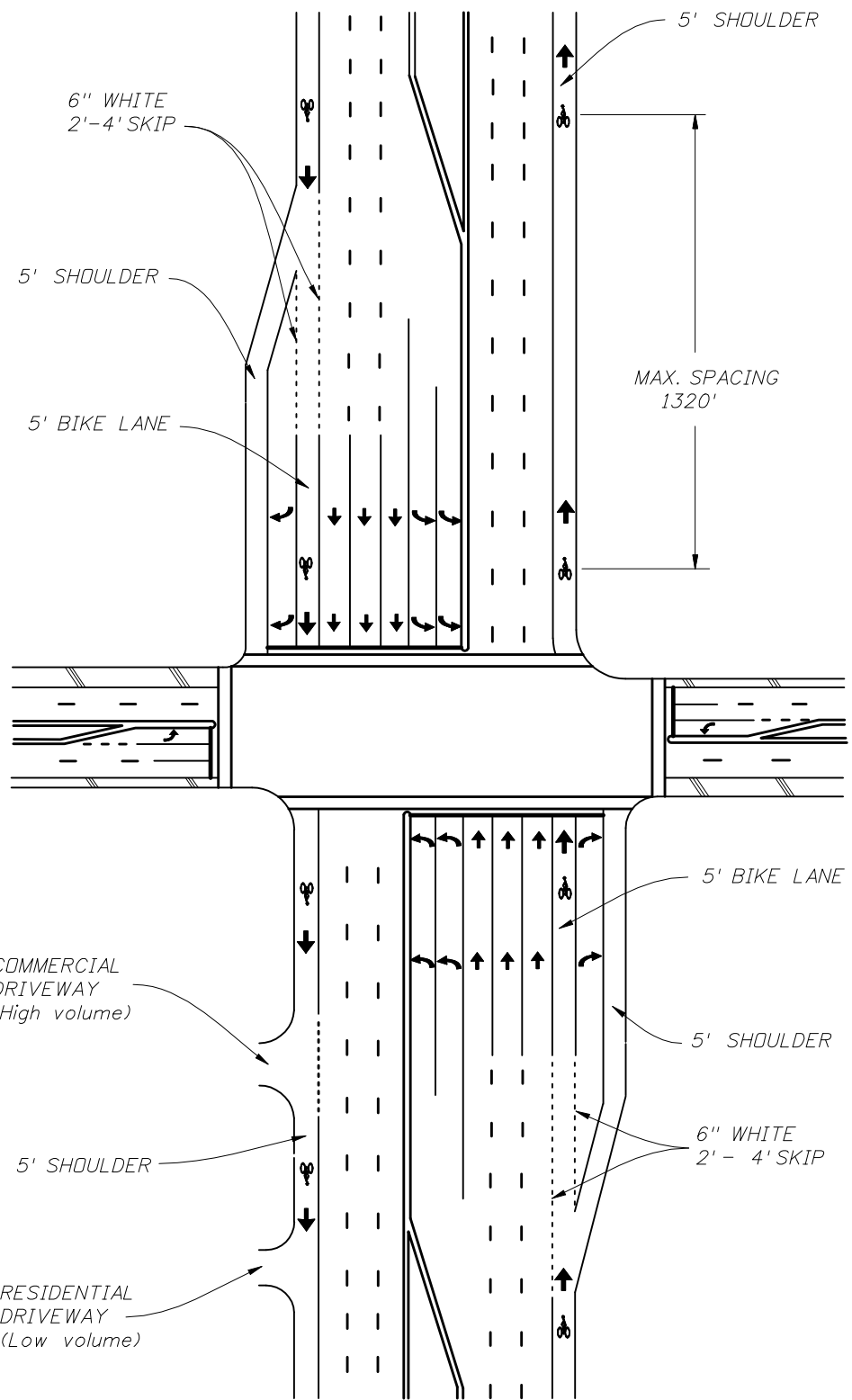

MAJOR INTERSECTION WITH DESIGNATED SHOULDER, AND SEPARATE RIGHT TURN LANE RURAL TYPICAL SECTION (PAVED SHOULDER)

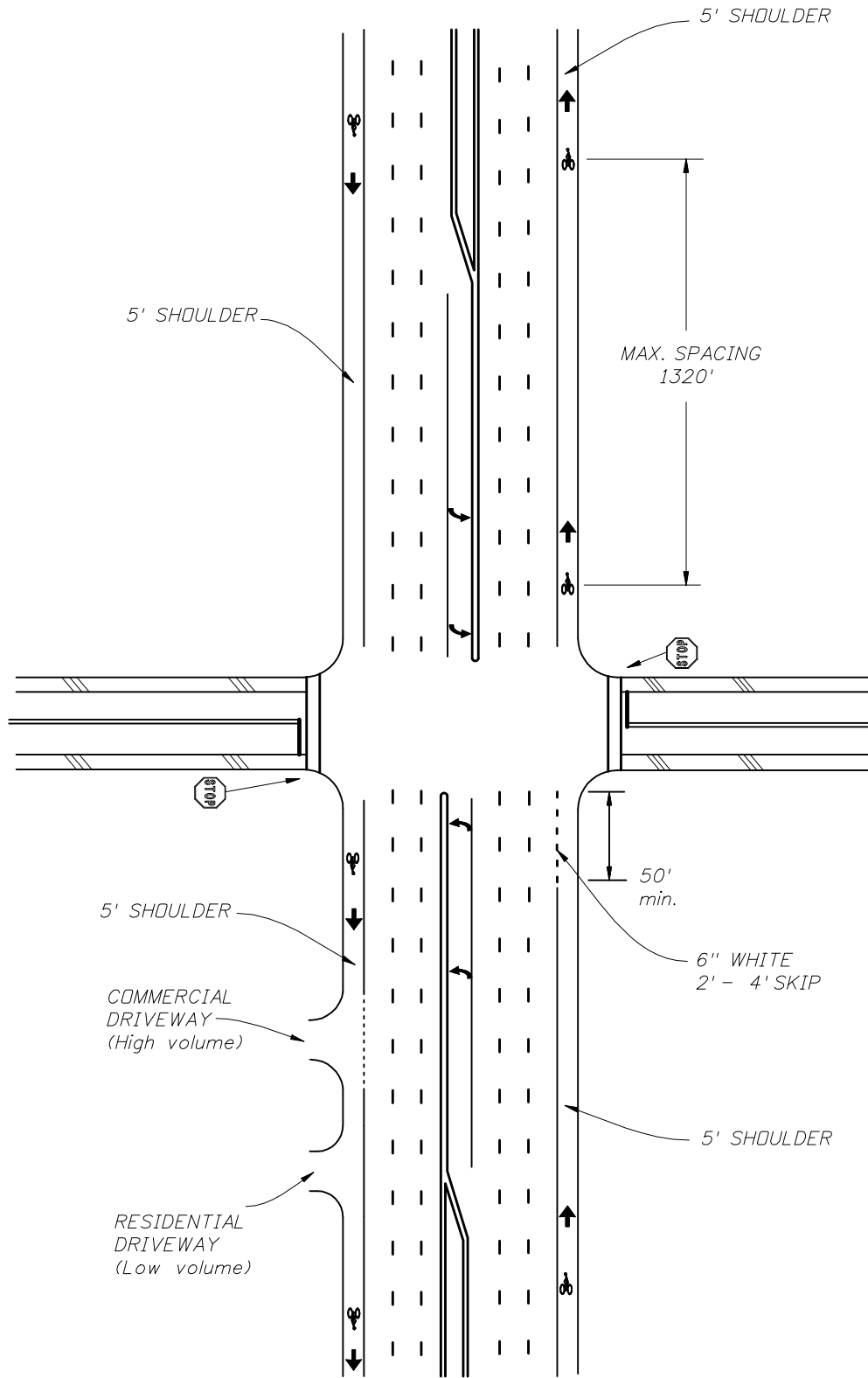

MAJOR WITH LOCAL STREET INTERSECTION, DESIGNATED SHOULDER, AND NO RIGHT TURN LANE RURAL TYPICAL SECTION (PAVED SHOULDER)

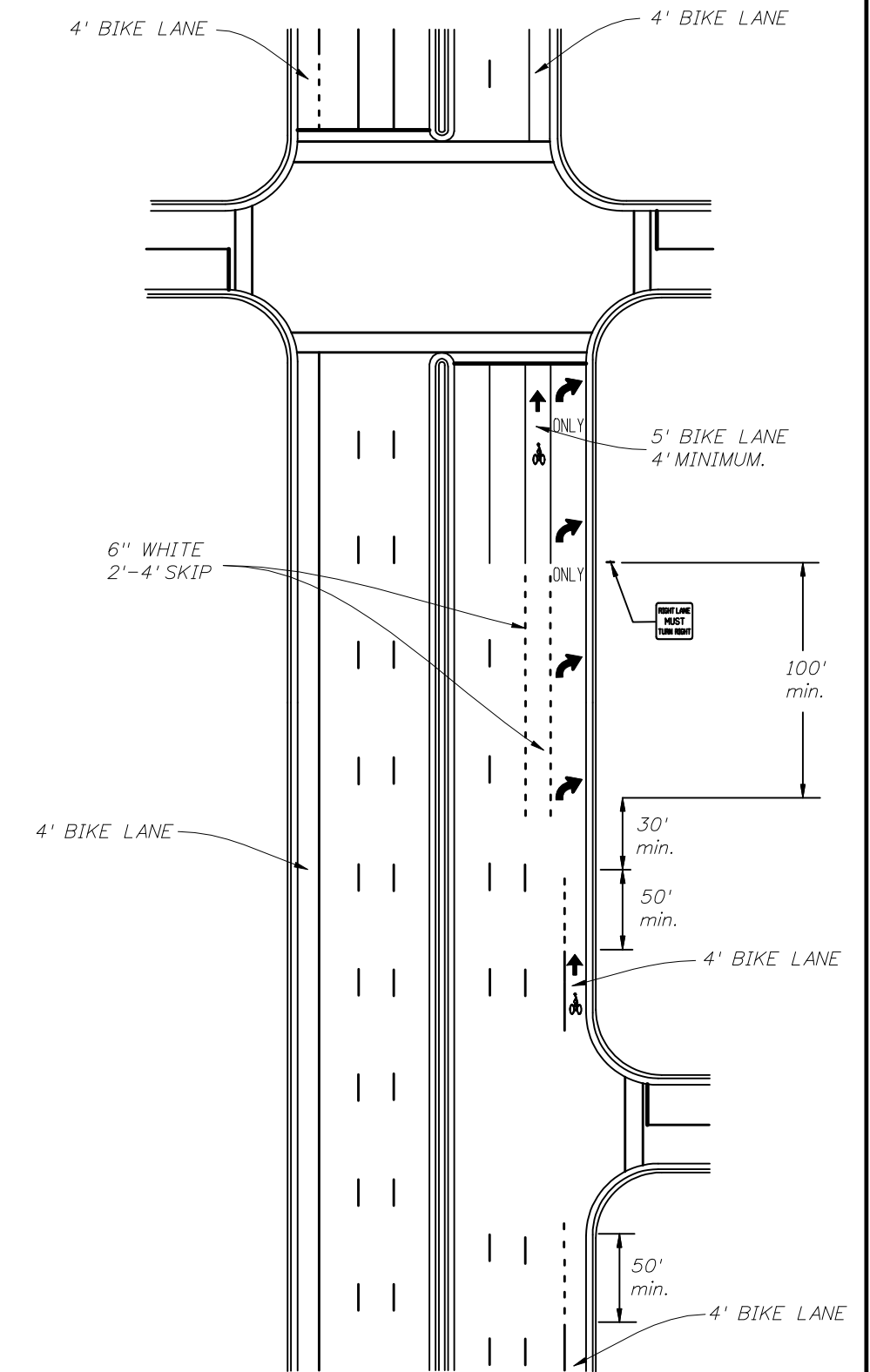

MAJOR INTERSECTION WITH RIGHT TURN DROP LANE AND DESIGNATED OR UNDESIGNATED BIKE LANE URBAN TYPICAL SECTION (CURB AND GUTTER)

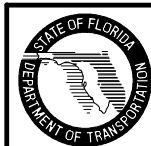

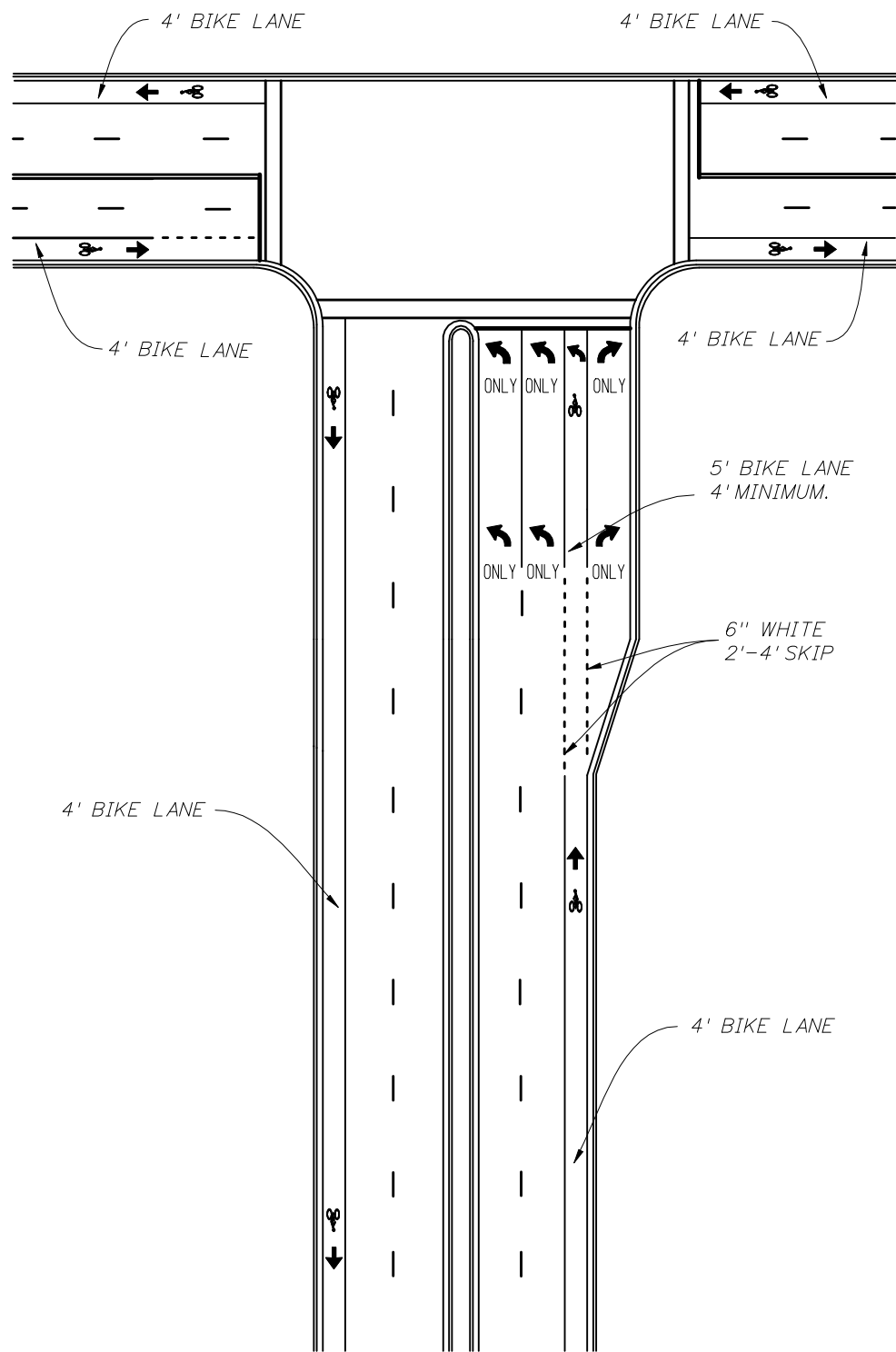

"TEE" INTERSECTION WITH SEPARATE RIGHT TURN LANE URBAN TYPICAL SECTION (CURB & GUTTER)

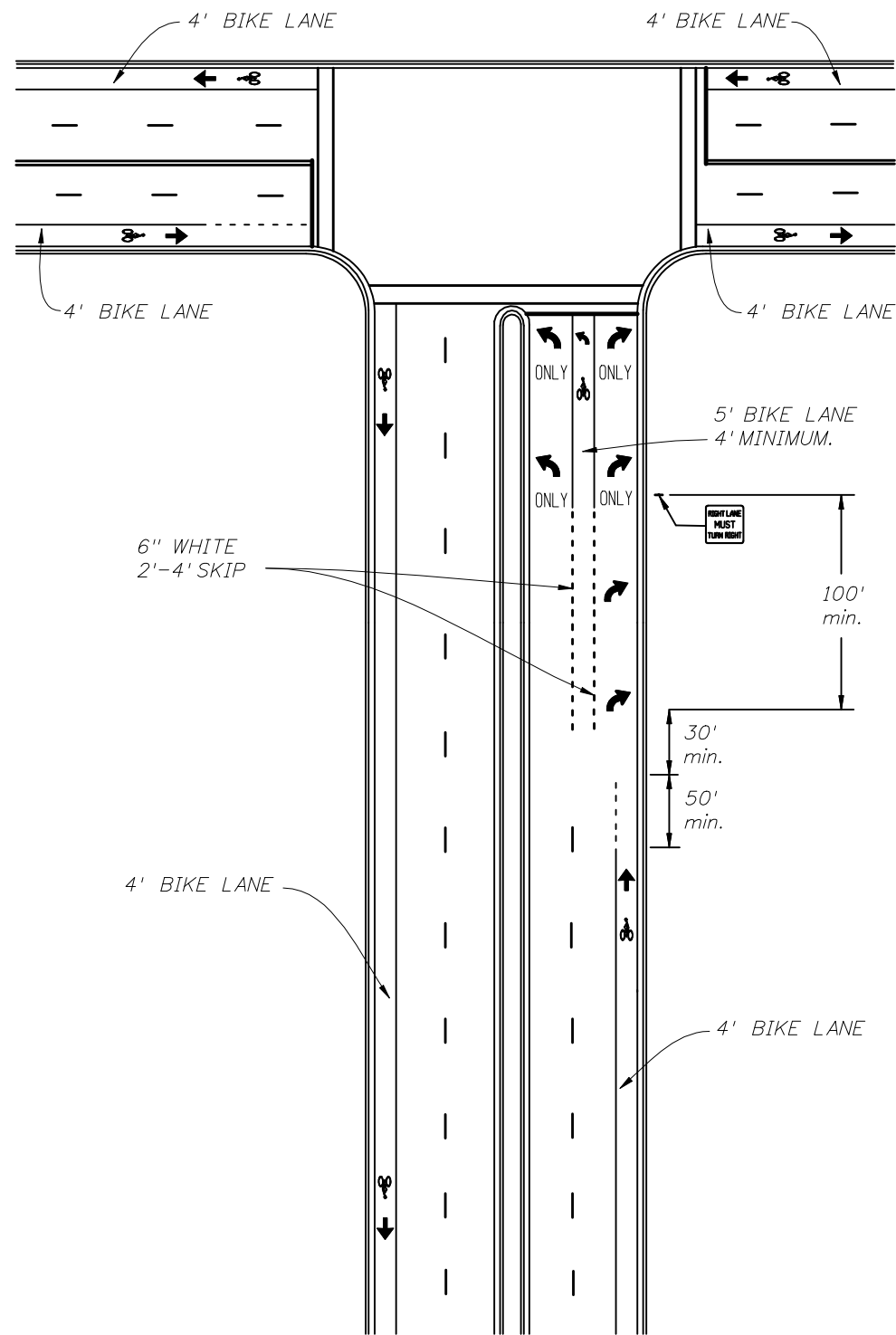

"TEE" INTERSECTION WITH RIGHT TURN DROP LANE URBAN TYPICAL SECTION (CURB & GUTTER)

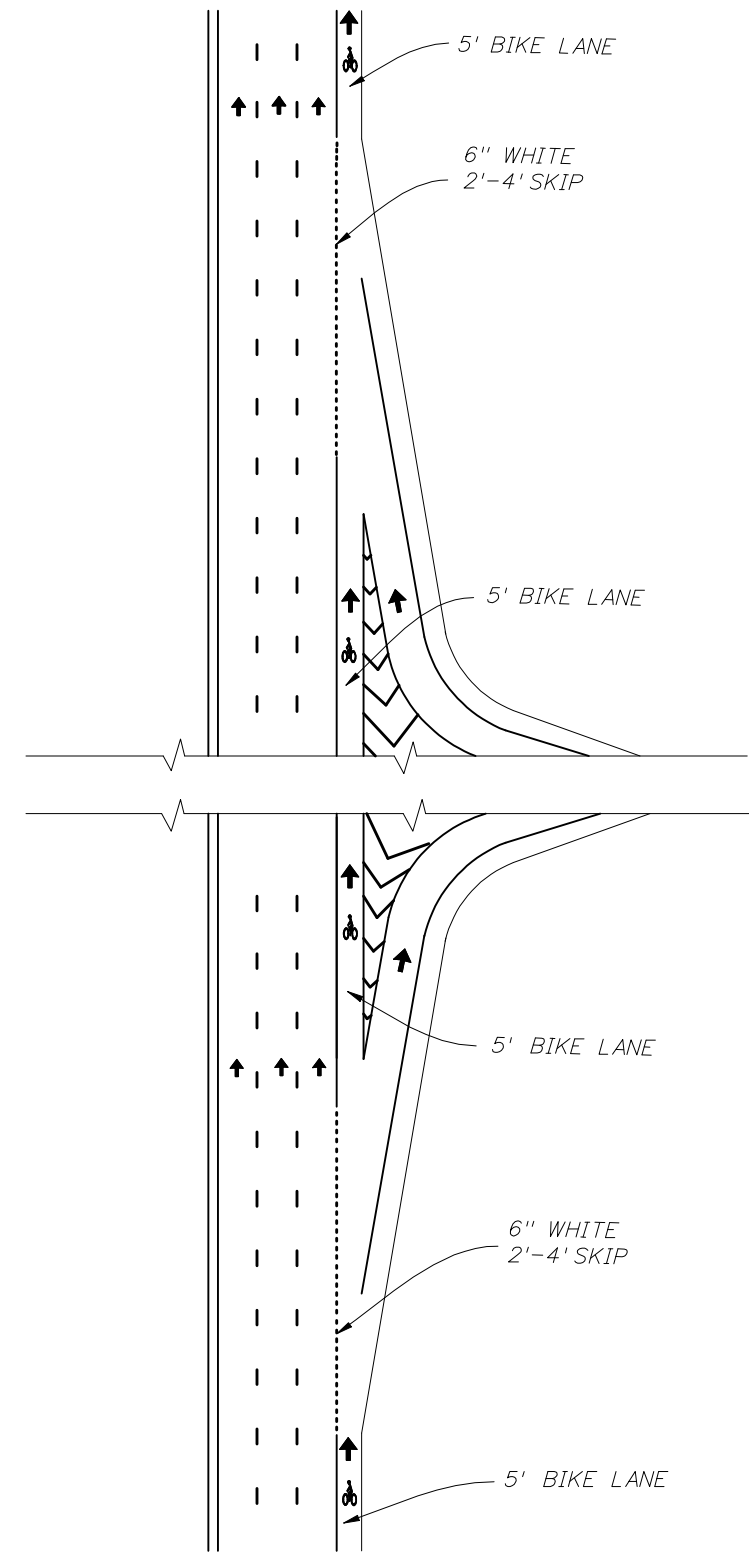

INTERCHANGE RAMP RURAL TYPICAL SECTION (PAVED SHOULDER)



CASE I Type 1 Object Markers shall consist of nine yellow reflectors mounted on a yellow reflective background or consist of a retroreflective panel of the same size.

CASE II End of Road Markers shall consist of nine red reflectors mounted on a red reflective background or consist of a retroreflective panel of the same size.

NOTES:

1. This index applicable to residential and minor streets only. Major streets to be evaluated on a case by case basis.
2. "T"-intersection-Two-Way arrows and reflectors are optional. The need should be based on a review of each location.
3. For additional details on aluminum round post, sign panel material and bolts, nuts and washers see Index Nos. 11860.
4. Case I Installation - The arrow panels and object markers shall be located approximately 20', but not less than 12' from the edge of the travel lane.
5. Dead end sign shall be posted a sufficient advance distance to permit the vehicle operator to avoid the dead end by turning off, if possible, at the nearest intersecting street.
6. For pavement marking see Index No. 17346
7. No guardrail is required unless special field conditions require its use.

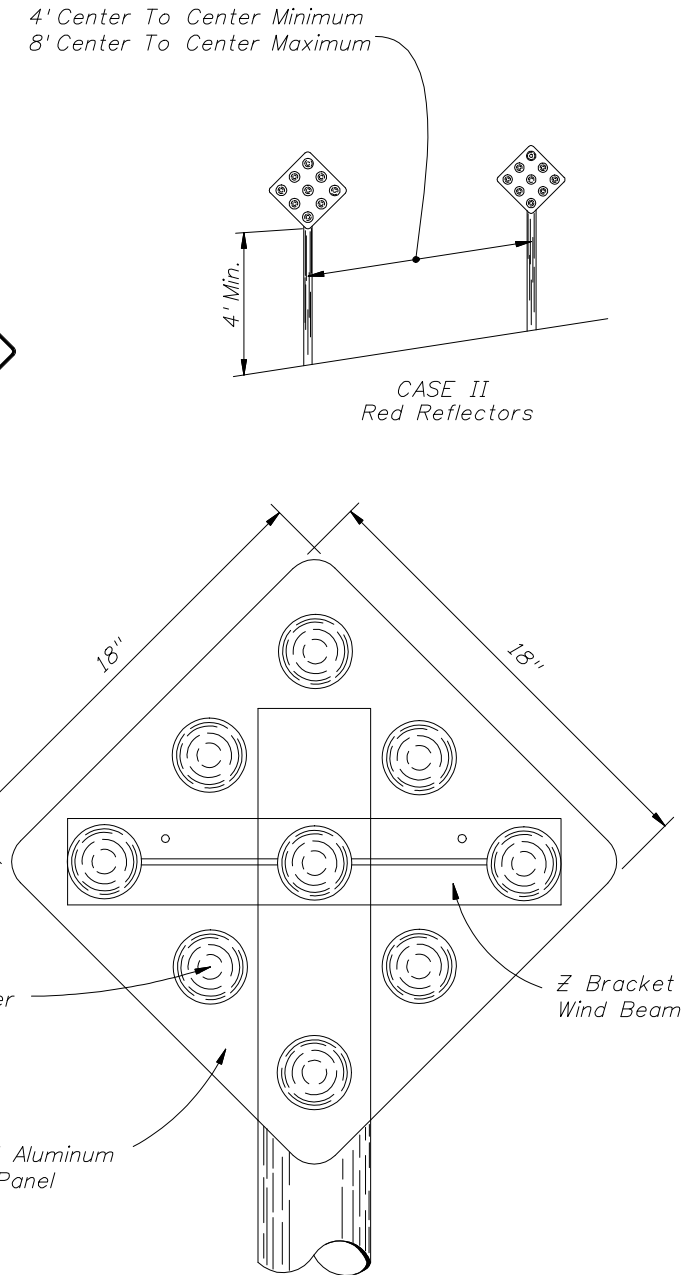
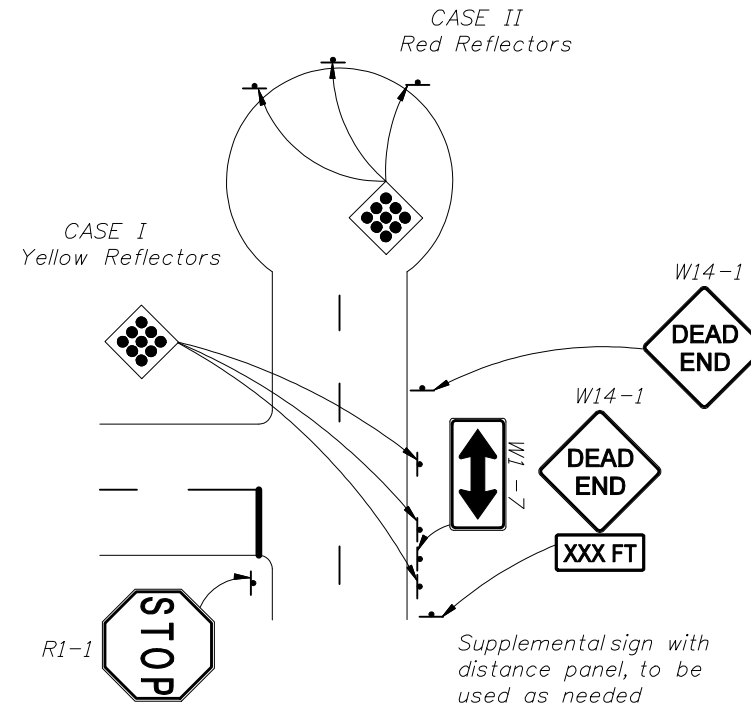
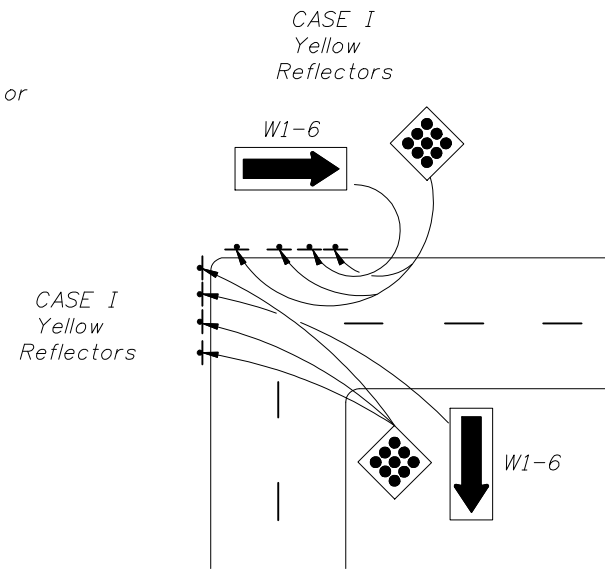

Object markers shall be installed on 2" ϕ x $\frac{1}{8}$ " Aluminum Round Post.
 $\frac{3}{8}$ " ϕ Aluminum Button Head Bolt with Nut and Lockwasher or $\frac{15}{16}$ " ϕ Stainless Steel Hex Head Bolt with Flat Washer under Head and Lockwasher under Nut. Post foundation shall be installed in accordance with Index No. 11860.

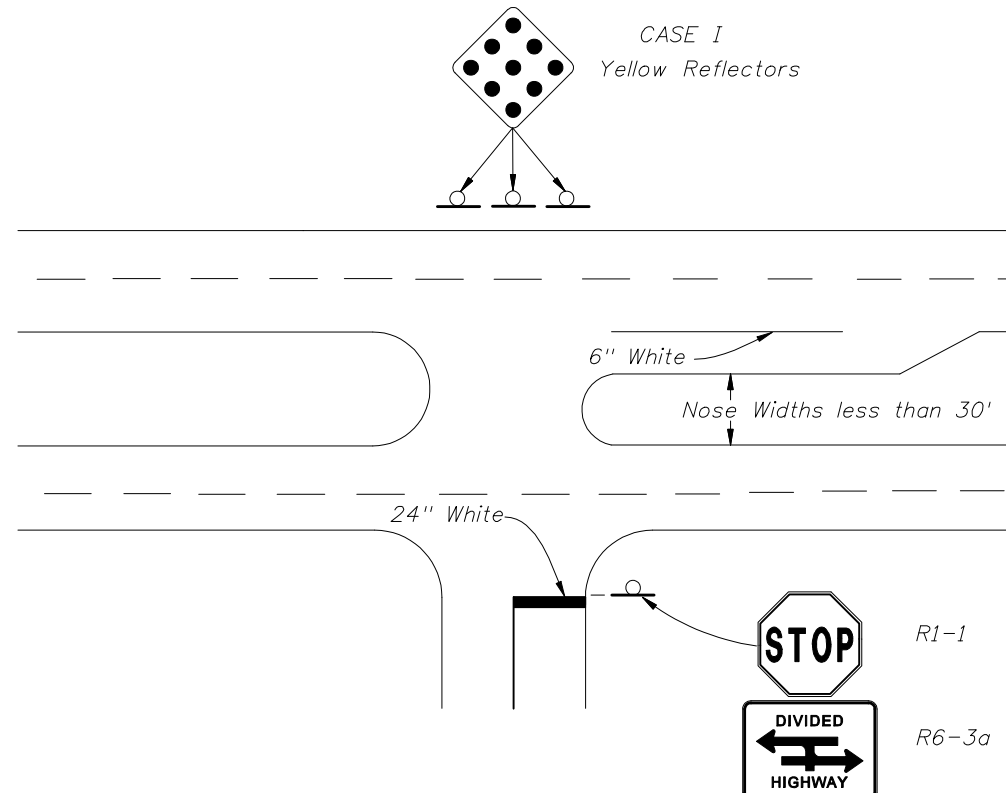
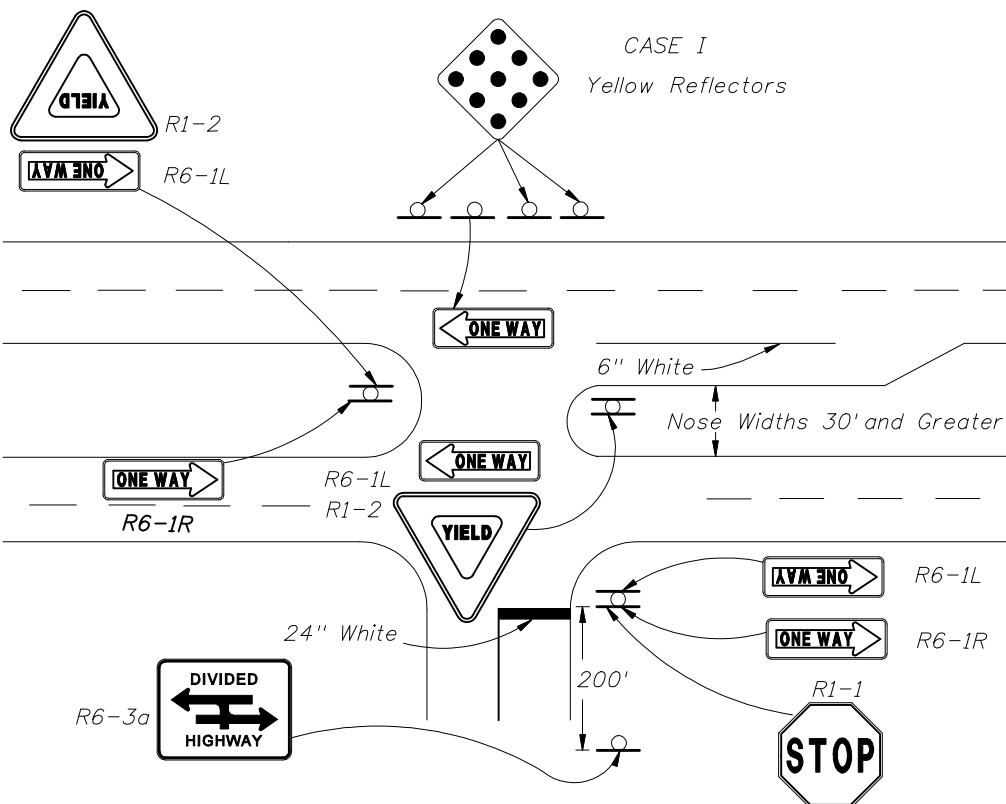

****Note:**

Two assemblies are required; one for each side of the ramp, showing those services in each particular direction from the ramp terminal.

Ramp mounted signs shall be installed to avoid conflict with existing signs and in no case should they be placed within 100' of another sign.

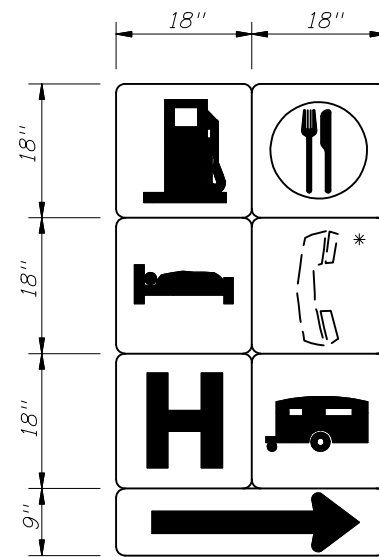

DETAIL "D"

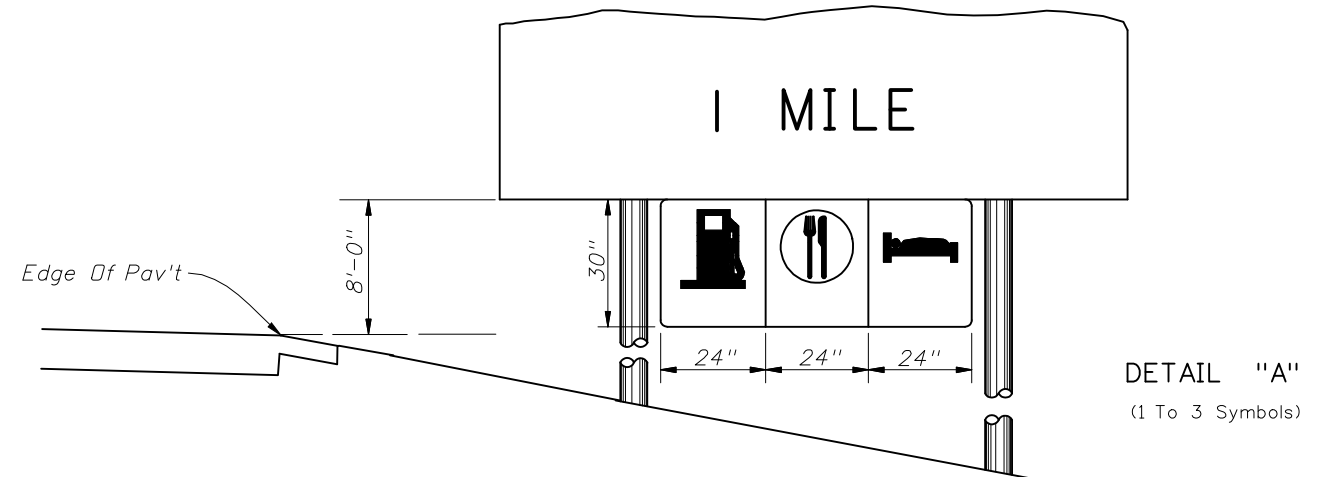

DETAIL "A"
(1 To 3 Symbols)

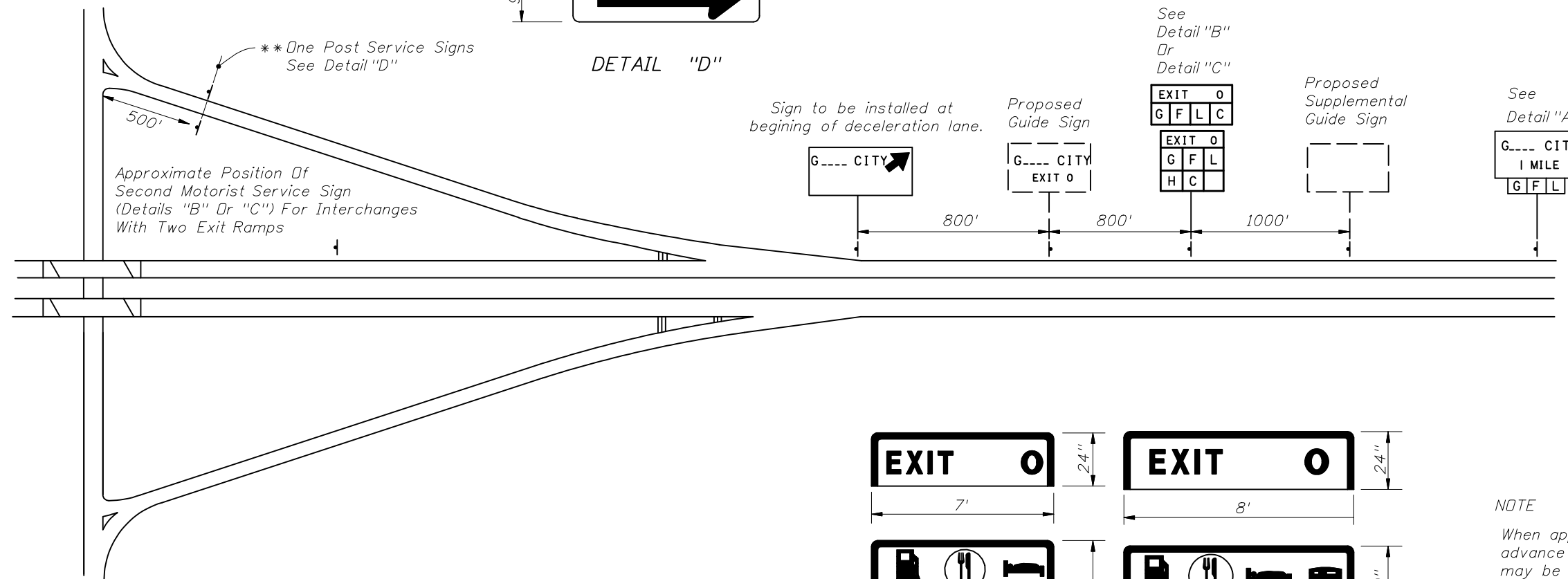

GENERAL NOTES

1. Only those services meeting criteria established by the Department and approved by the State Traffic Operations Engineer for each interchange shall be shown. Symbols for motorist services shall always appear in the following order reading from left to right and top to bottom: Gas, Food, Lodging, Phone *, Hospital, Camping. The phone symbol shall not be shown whenever any Gas, Food, Lodging or Camping symbol appears.
2. Symbols shall appear consecutively on the sign with no positions left blank or reserved for intermediate symbols not currently approved for a particular interchange.
3. All motorist service signs to have White Legend and Border with Blue Background.
4. For mounting details see Index 11200 for Type "A" breakaway or Index 11860 for Type "C" Frangibility.

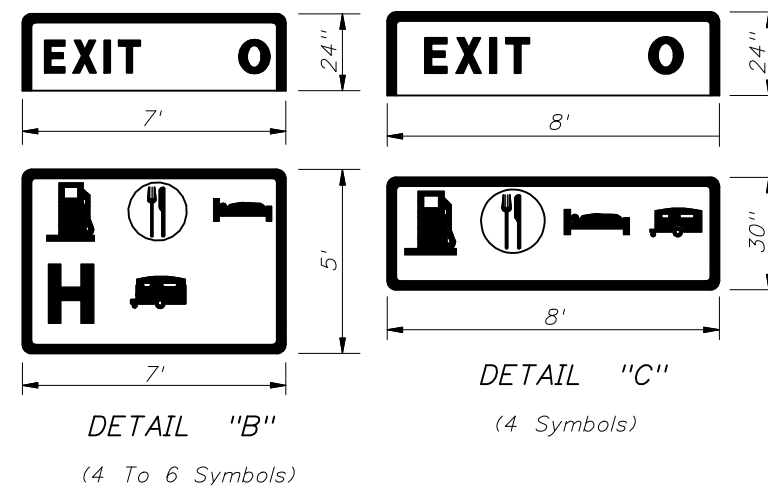

DETAIL "B"
(4 To 6 Symbols)

DETAIL "C"
(4 Symbols)

NOTE

When approved for attachment to the advance guide signs, up to 3 services may be used for an exit. The symbol signs shall be suspended from the guide sign panel or existing wind beams. Symbol signs are not to be connected to existing sign posts.

The mounting height of the advance guide sign shall be increased, where necessary, to provide 8' between the level of the pavement edge and the bottom of the guide sign, prior to mounting the supplementary panel.





Sign No. FTP-10-06

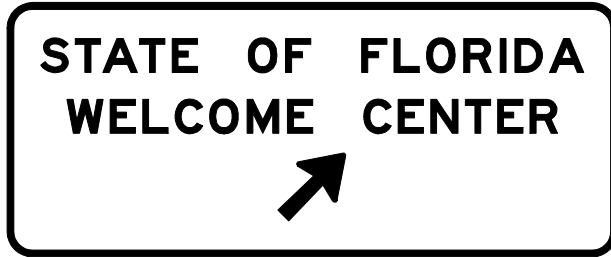

Sign No. FTP-11-06

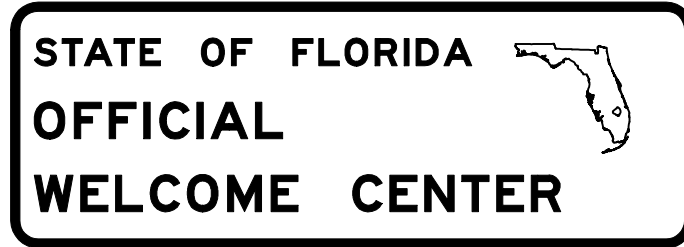

Sign No. FTP-12-06



Sign No. FTP-13-06

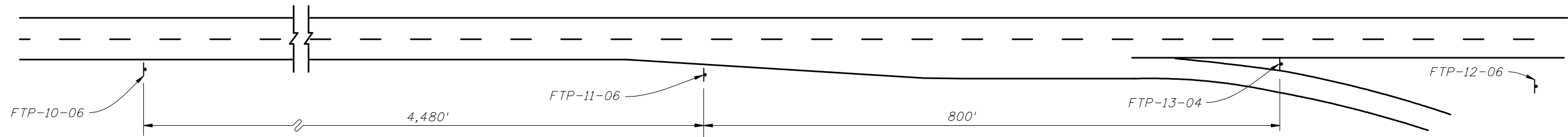

Note : Roadway not drawn to scale
Distances shown are adequate for driver communication
but may be altered slightly if conditions require.



Sign No. FTP-14-06

Note: Sign FTP-14-06 shall be used as a supplemental guide sign at interchanges which have a Tourist Information Center approved for such signing (locate half-way between normal guide signs)

Notes:

1. Signs and sign structures shall be erected in accordance with the details shown on Index No. 11200.
2. Sign FTP-12-06 shall be located on the Welcome Center grounds in proximity to the building and as far from the main line roadway as possible (2 signs back to back).
3. Sign FTP-10-06, 11-06, 12-06 shall be located as limited access highways only.
4. All legend to be Series E.
5. See Index No. 17355 for sign details.

FOR LIMITED ACCESS HIGHWAYS



2010 FDOT Design Standards

WELCOME CENTER SIGNING

Last Revision 07/01/07	Sheet No. 1 of 2
Index No. 17351	

**STATE OF FLORIDA
WELCOME CENTER
1 MILE**

SIGN NO. FTP-15A-04

STATE OF FLORIDA 
**OFFICIAL
WELCOME CENTER**

SIGN NO. FTP-12-04

1/2 MILE

SIGN NO. FTP-15B-04



SIGN NO. FTP-15C-04

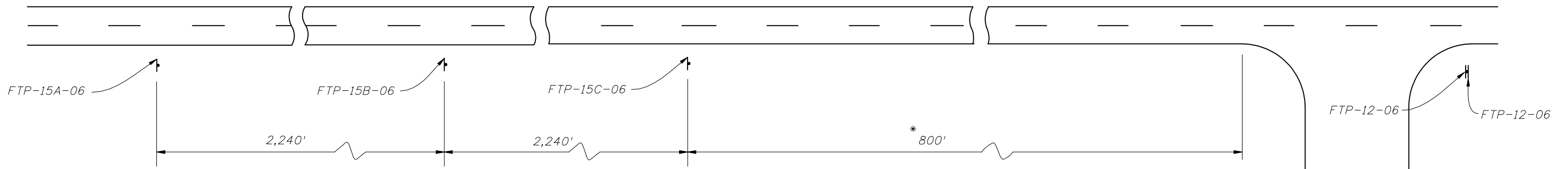

* 800' Maximum For Rural Conditions
50' Minimum For Rural Conditions

Notes:

1. Signs and sign structures shall be erected in accordance with the details shown on Index 11200.
2. Sign FTP-12-06 shall be located on the Welcome Center grounds in proximity to the building and as far from the Main Line Roadway as possible (2 signs back to back).
3. All legend to be Series E.
4. One sign FTP-15A-06 or 15B-06 should be used depending on speed, roadside development & geometric conditions.

FOR PRIMARY HIGHWAYS

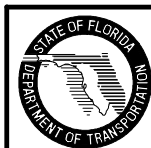

2010 FDOT Design Standards

WELCOME CENTER SIGNING

Last Revision 07/01/07	Sheet No. 2 of 2
Index No. 17351	

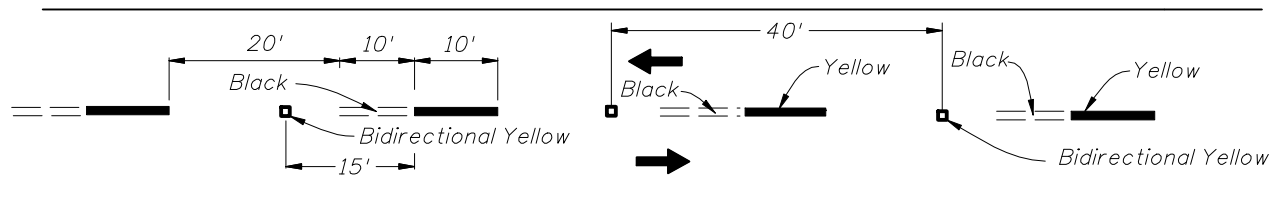

ALTERNATING SKIP LINE

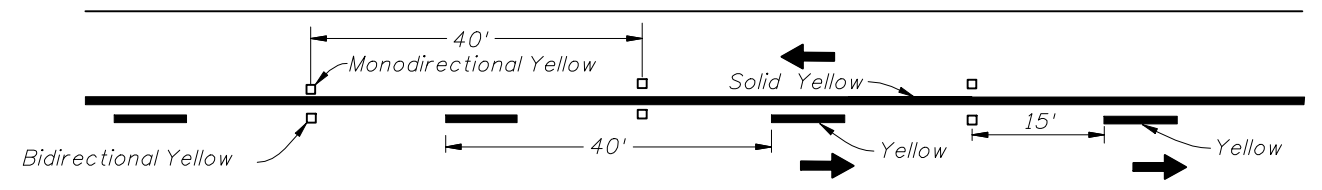

SOLID LINE WITH SKIP

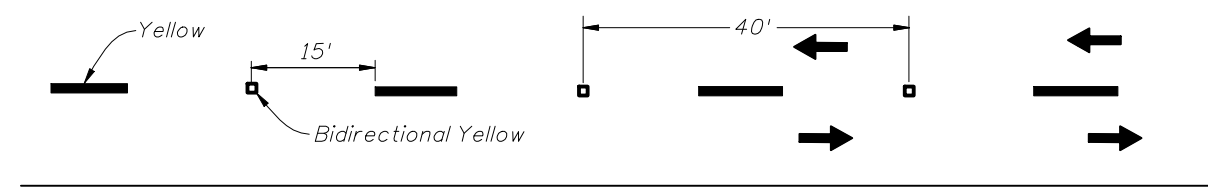

SKIP LINE

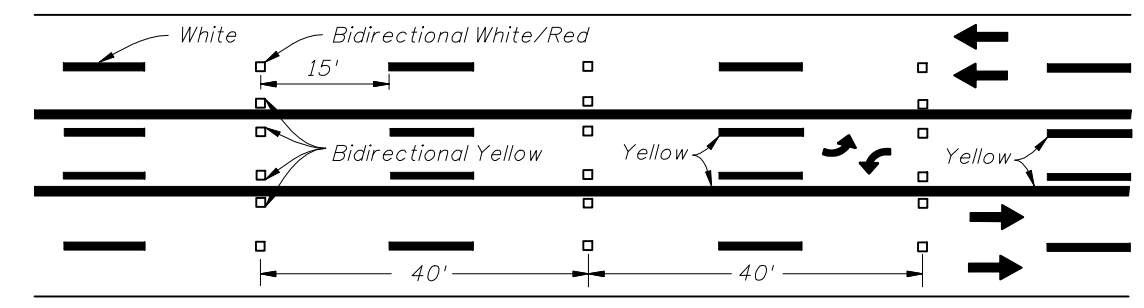

SKIP LINE WITH TWO-WAY LEFT TURN LANE

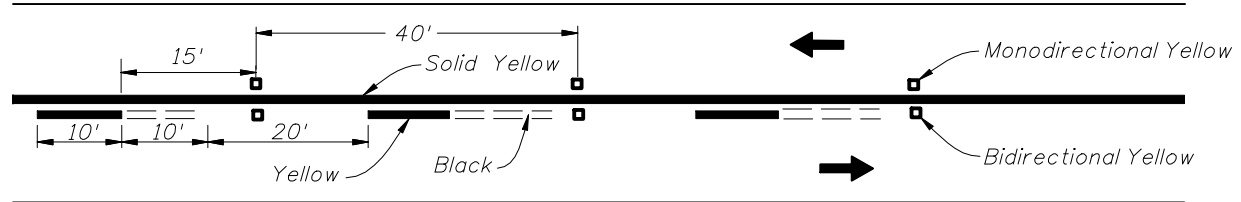

SOLID LINE WITH ALTERNATING SKIP

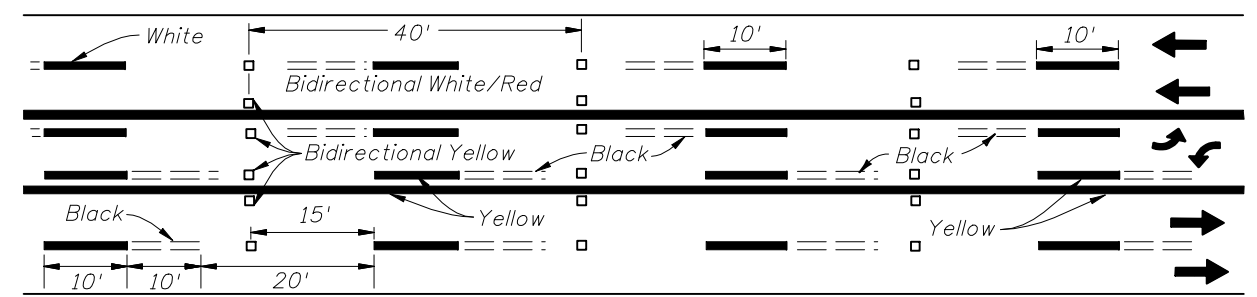

ALTERNATING SKIP LINE WITH TWO-WAY LEFT TURN LANE

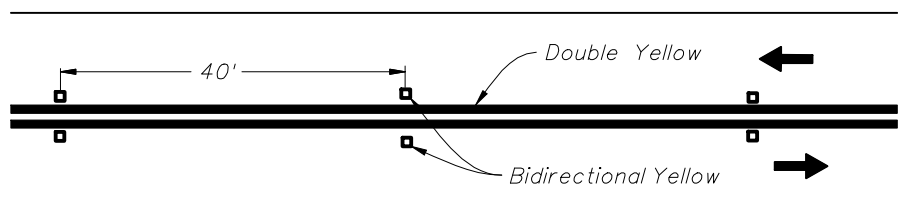

DOUBLE SOLID LINE

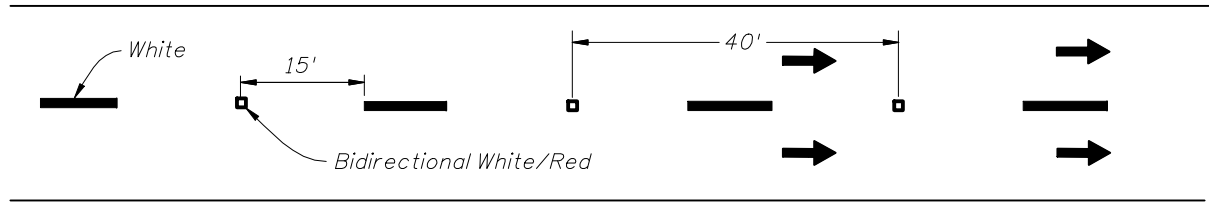

MULTILANE

1. Reflective Pavement Markers shall be spaced at 40' on all skip lane lines and skip center lines. This spacing may be reduced to 20' if specifically called for in the plans.
2. The spacing on solid lines and solid/skip combination lines shall be 40'.
3. All RPM's shall be offset 1" from solid lines.
4. These spacings may be reduced for sharp curves if required.
5. All RPM's shall be class "B".

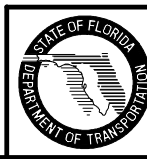

NOTE

Raised pavement markers shall be set 1" from line.

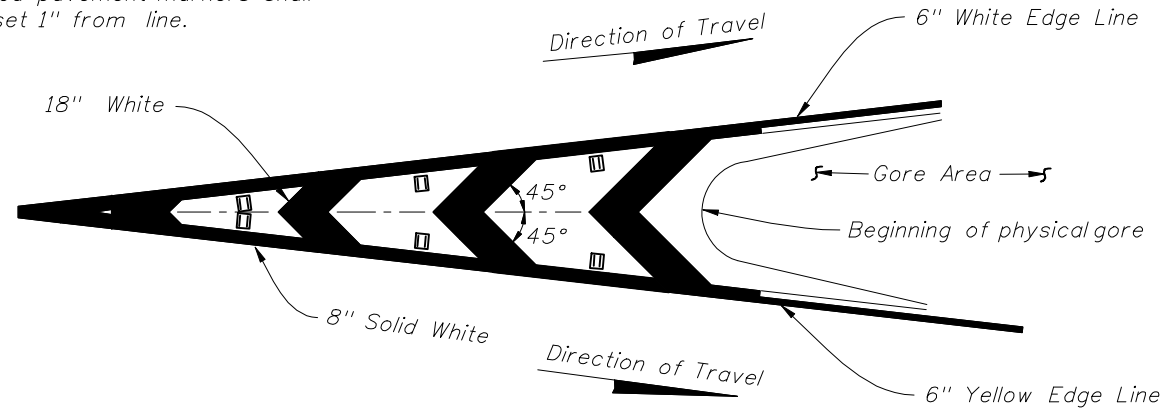

RPM PLACEMENT FOR TRAFFIC CHANNELIZATION AT GORE
(TRAFFIC FLOWS IN SAME DIRECTION)

NOTE

Raised pavement markers (Bidirectional White/Red) should be used in all gores of this type

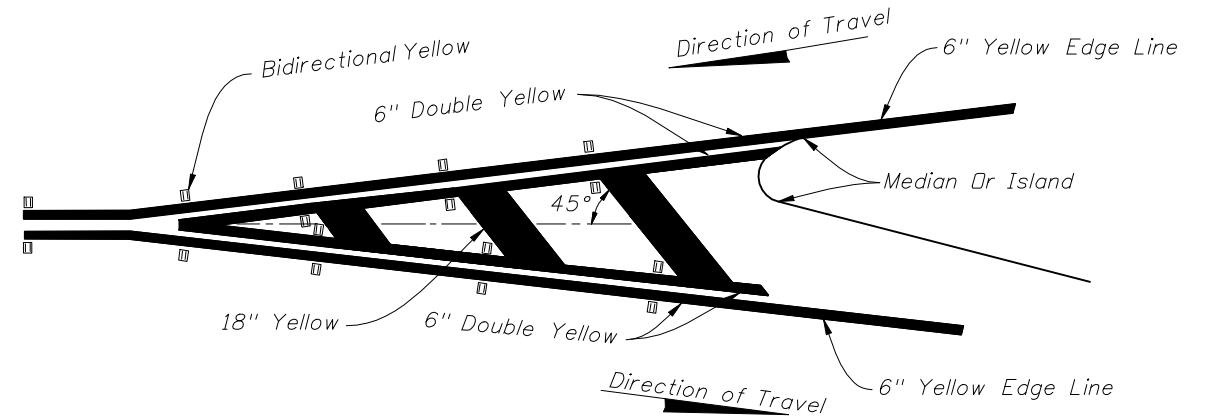
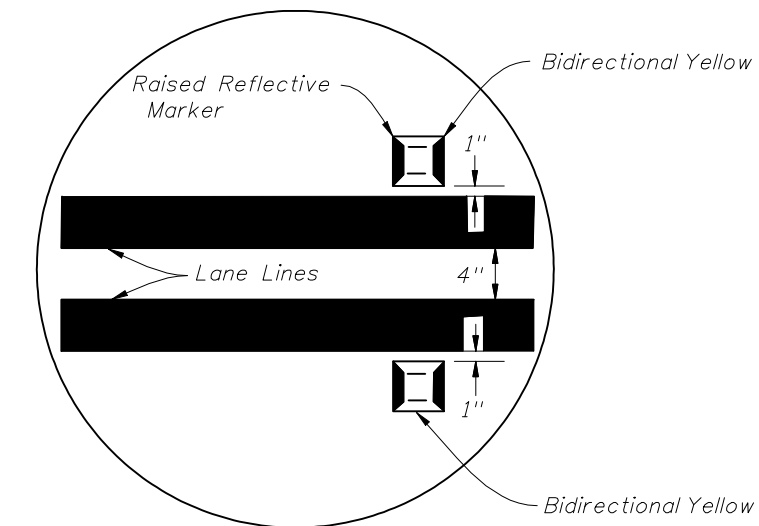

RPM PLACEMENT FOR TRAFFIC SEPARATION
(TRAFFIC FLOWS IN OPPOSITE DIRECTION)

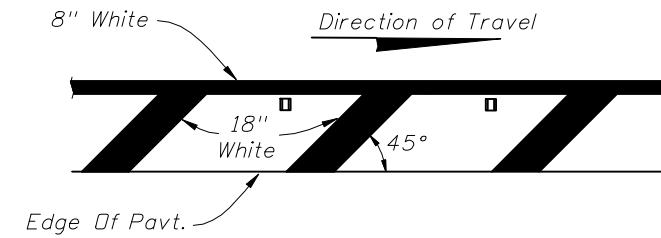

PLACEMENT OF RPM'S ON SHOULDER MARKINGS

For Left Side Of Roadway The Plan Is Opposite Hand And Markings Shall Be Yellow.

For Placement Of Rpm's On Ramps See Index 17345.

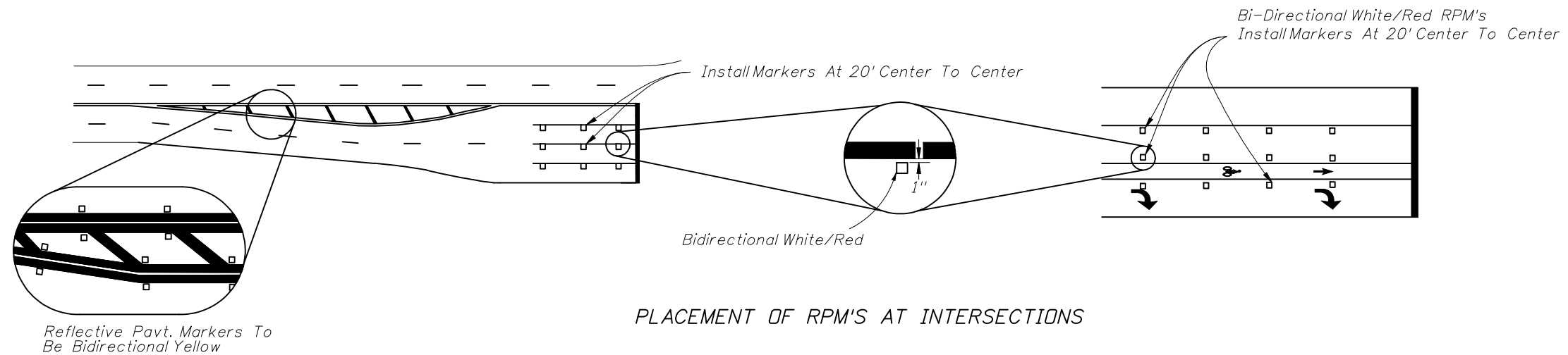

PLACEMENT OF RPM'S AT INTERSECTIONS

Reflective Pavt. Markers To Be Bidirectional Yellow



2010 FDOT Design Standards

TYPICAL PLACEMENT OF
REFLECTIVE PAVEMENT MARKERS

Last Revision	Sheet No.
07/01/05	2 of 2
Index No.	
17352	

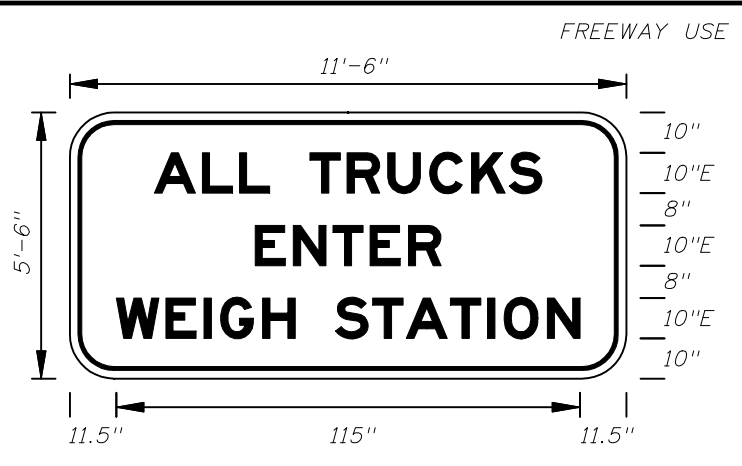

FTP-1-06
11'-6" X 5'-6"
9" Radii 2" Border
10" Series E Legend
White Background
Black Legend and Border

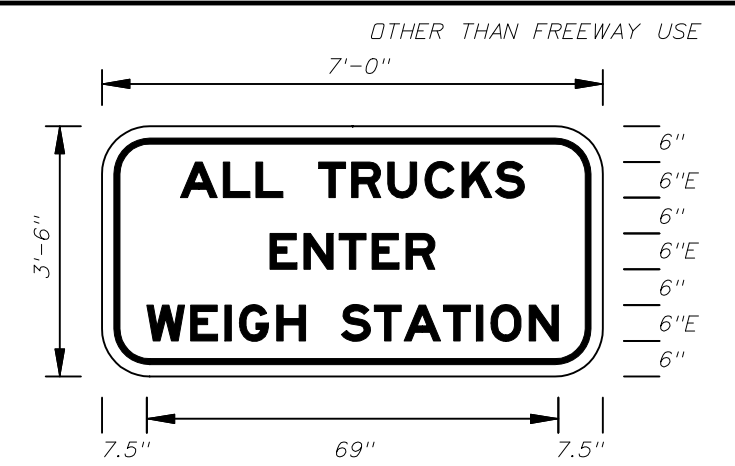

FTP-2-06
7' X 3'-6"
6" Radii 2" Border
6" Series E Legend
White Background
Black Legend and Border

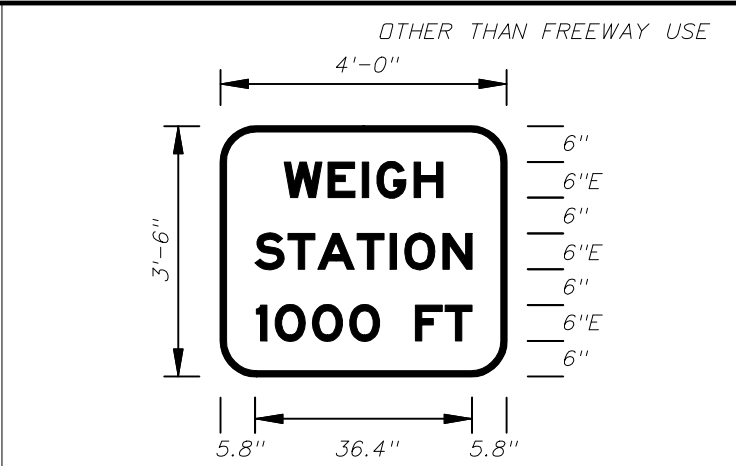

FTP-3-06
4' X 3'-6"
6" Radii 2" Border
6" Series E Legend
Green Background
White Legend and Border

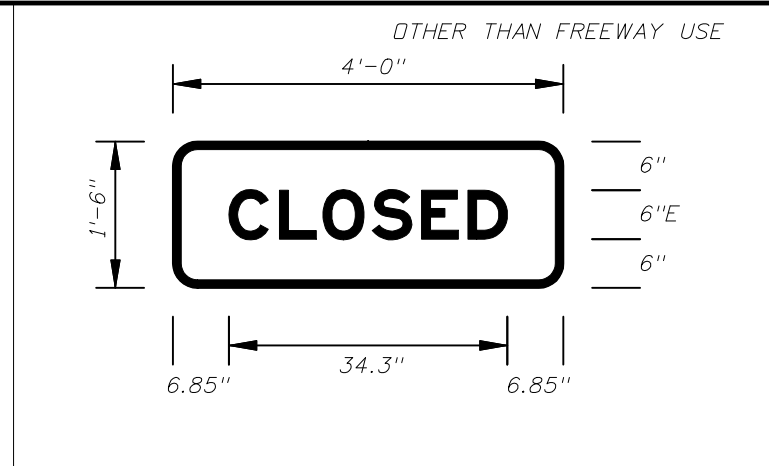

FTP-4-06
4' X 1'-6"
3" Radii 2" Border
6" Series E Legend
Green Background
White Legend and Border

Note:
FTP-4-06 to be used with FTP-3-06

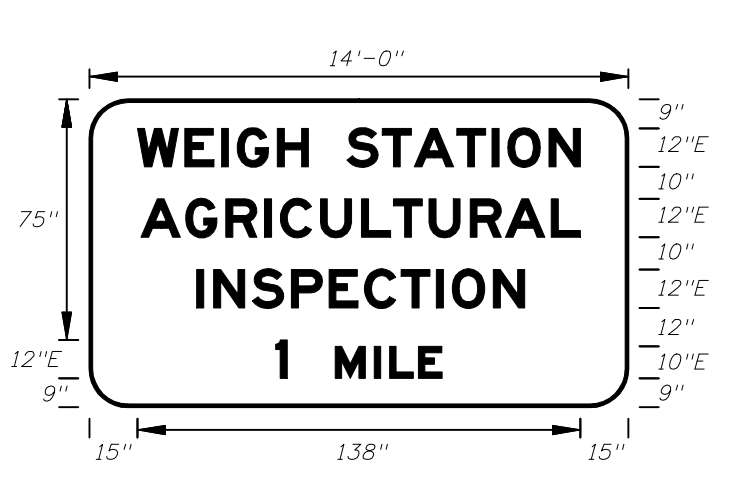

FTP-5-06
14' X 8'
12" Radii 2" Border
12" and 10" Series E Legend
Green Background
White Legend and Border

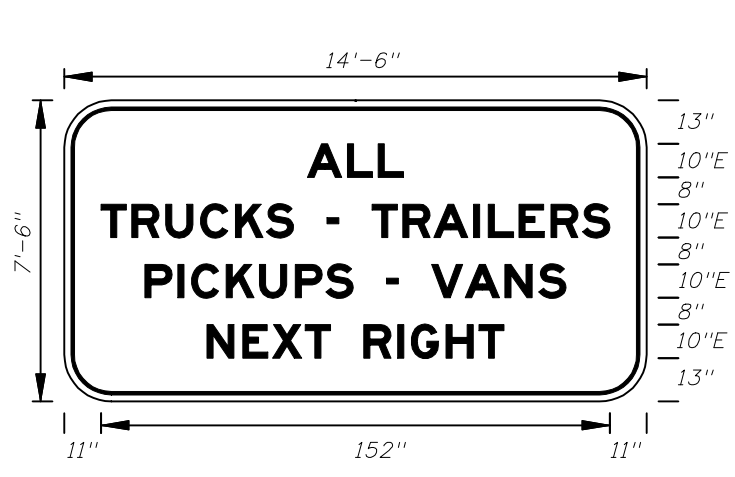

FTP-6A-06
14'-6" X 7'-6"
12" Radii 2" Border
10" Series E Legend
White Background
Black Legend and Border

On Interstate Station
Delete Pickups-Vans,
and reduce Sign height
accordingly.

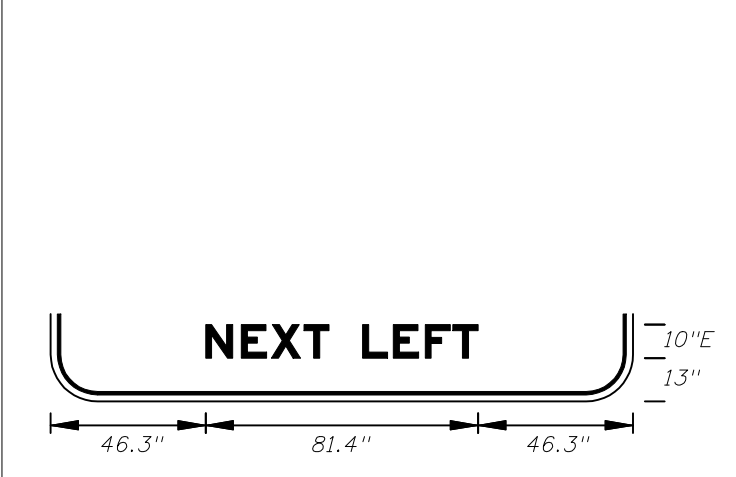

FTP-6B-06
14'-6" X 7'-6"
12" Radii 2" Border
10" Series E Legend
White Background
Black Legend and Border



FTP-7A-06
12' X 7'
11" Radii 2" Border
10" Series E Legend
Green Background
White Legend and Border

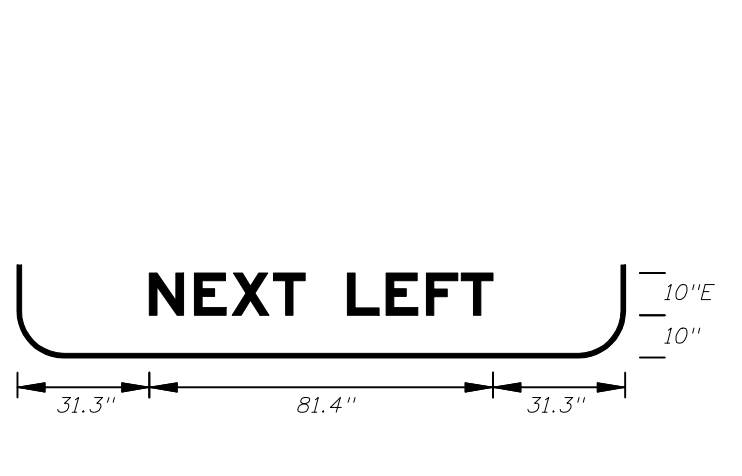

FTP-7B-06
12' X 7'
11" Radii 2" Border
10" Series E Legend
Green Background
White Legend and Border

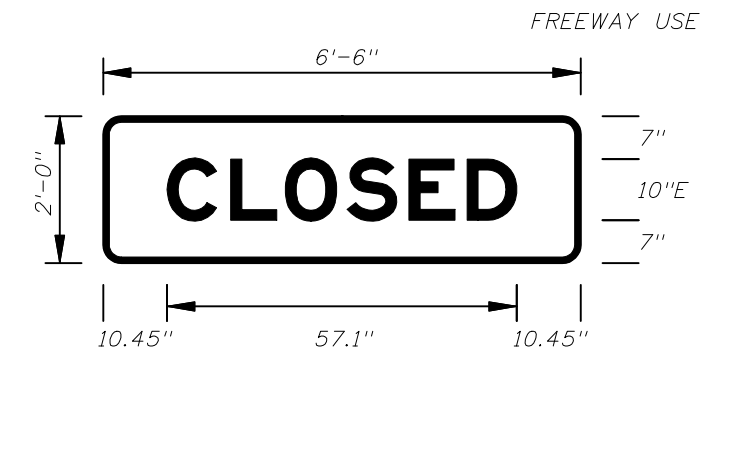

FTP-8-06
6'-6" X 2'
3" Radii 2" Border
10" Series E Legend
Green Background
White Legend and Border

Note:
FTP-8-06 to be used with FTP-7A-06 & FTP-7B-06.

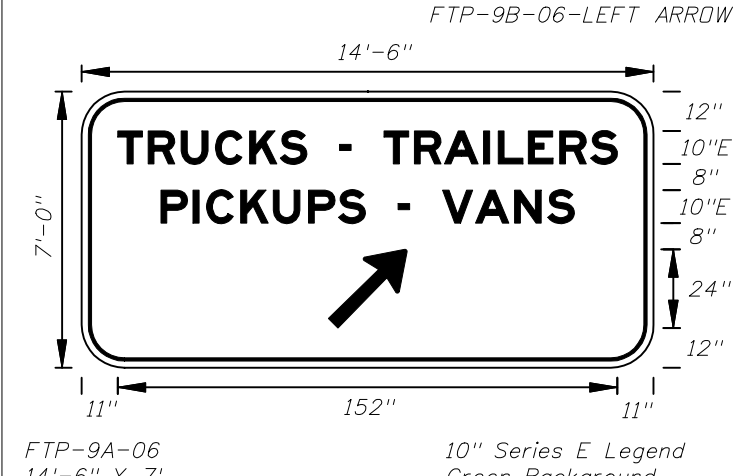

FTP-9A-06
14'-6" X 7'
11" Radii 2" Border

FTP-9B-06-LEFT ARROW
10" Series E Legend
Green Background
White Legend and Border

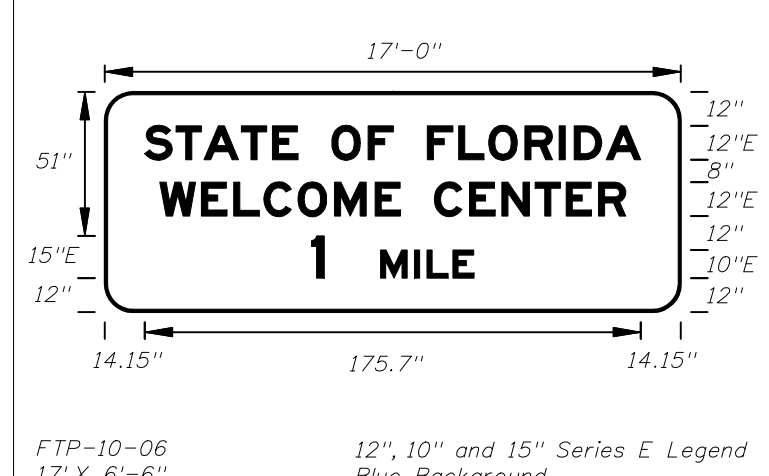

FTP-10-06
17' X 6'-6"
10" Radii 2" Border

12", 10" and 15" Series E Legend
Blue Background
White Legend and Border



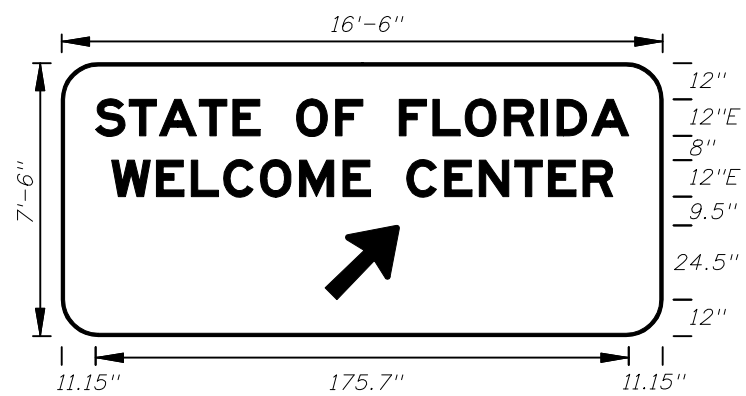

FTP-11-06
16'-6" X 7'-6"
12" Radii 2" Border
12" Series E Legend
Blue Background
White Legend and Border

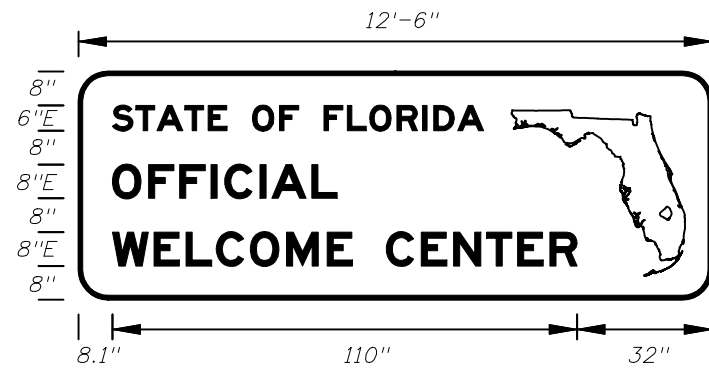

FTP-12-06
12'-6" X 4'-6"
7" Radii 2" Border
6" and 8" Series E Legend
Blue Background
White Legend and Border

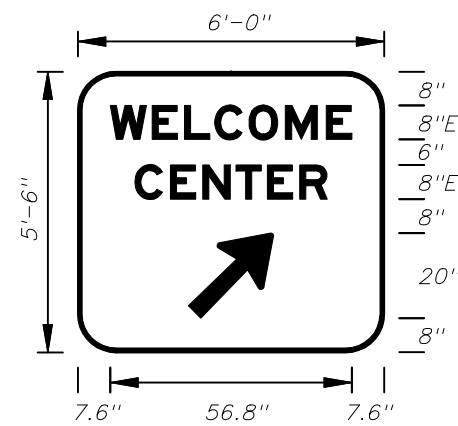

FTP-13-06
6' 0" X 5'-6"
9" Radii 2" Border
8" Series E Legend
Blue Background
White Legend and Border

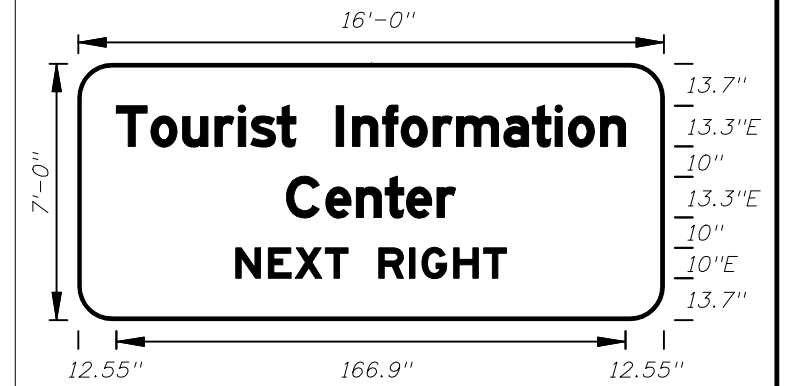

FTP-14-06
16'-0" X 7'-0"
11" Radii 2" Border
13.3 and 10" Series E Legend
Blue Background
White Legend and Border

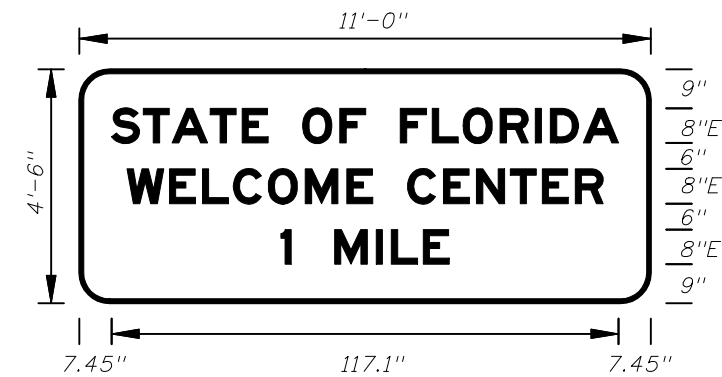

FTP-15A-06
11'-0" X 4'-6"
7" Radii 2" Border
8" Series E Legend
Blue Background
White Legend and Border

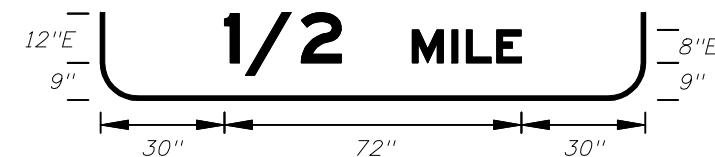

FTP-15B-06
11'-0" X 5'-0"
8" Radii 2" Border
8" and 12" Series E Legend
Blue Background
White Legend and Border

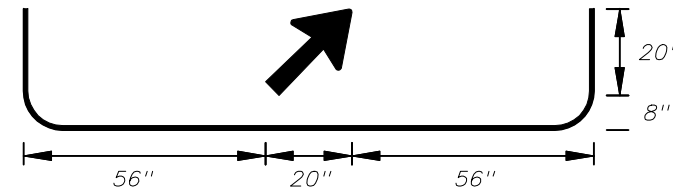

FTP-15C-06
11'-0" X 5'-6"
9" Radii 2" Border
8" Series E Legend
Blue Background
White Legend and Border

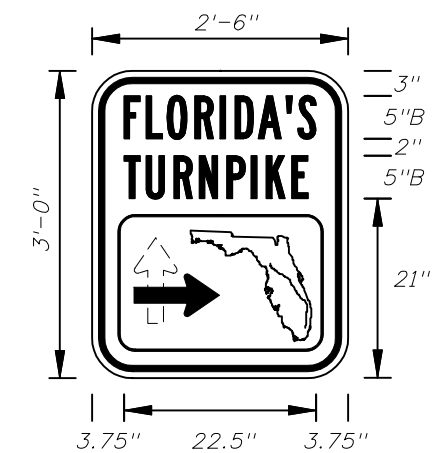

FTP-16-06
2'-6" X 3'-0"
4" Radii 2" Border
5" Series B Legend
Green Background
White Legend and Border

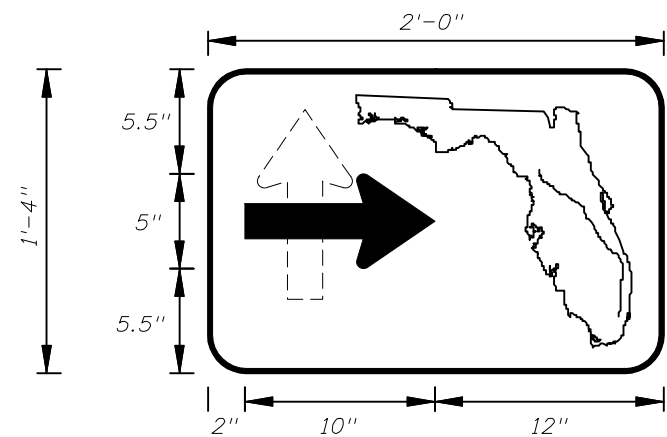

FTP-16-06 DETAIL
2' X 1'-4"
2" Radii 1" Border
White Background
Black Legend and Border

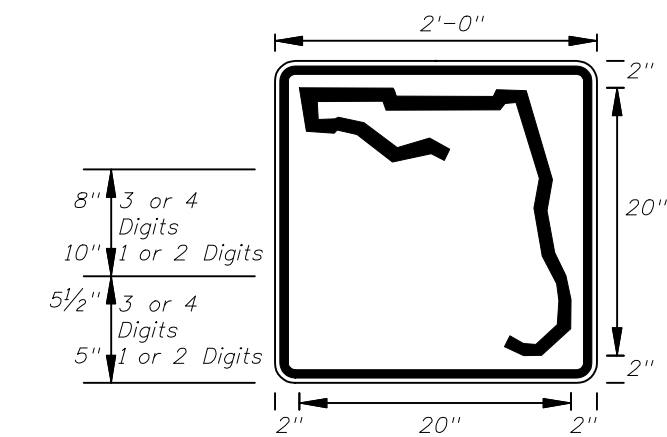

FTP-17-06
2' X 2'
1.13" Radii .0521" Border
White Background
Black Legend and Border

See Sheet 3 of 11
For Additional Details



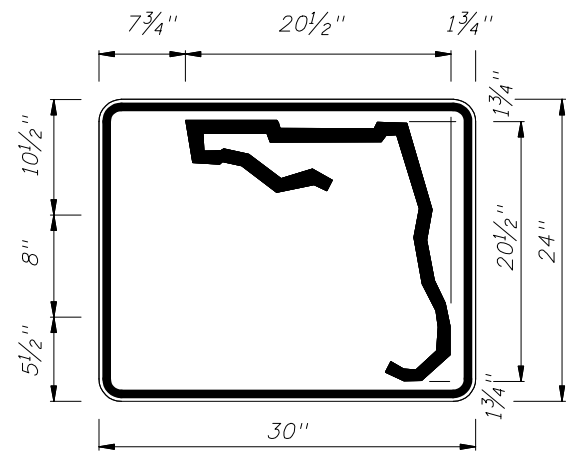

3 or 4 DIGITS

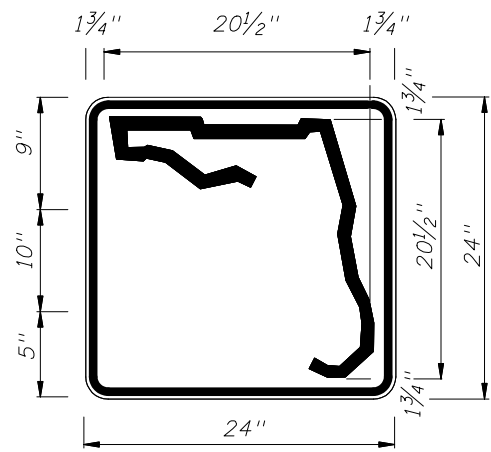

1 or 2 DIGITS

DIGITS	NUMERAL SIZE	SERIES	PANEL SIZE
1-2	10"	D	24" x 24"
3-4	8"	D	24" x 24"
3	8"	C	30" x 24"
4	8"	C	30" x 24"

Note :
The 24" X 24" panel shall only be used for a 3 or 4 digit route when the panel is to be used on a sign cluster with other 24" X 24" panels.

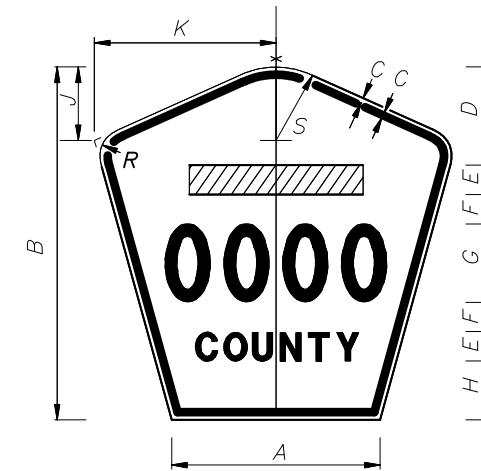

- Notes :
- All Legend Series "D".
 - Color: Yellow Legend and Border on Blue Background.
 - When used on a guide sign, marker must be overlaid on a rectangular Yellow Background as shown in chart. **

INDEPENDENT USE OTHER THAN FREEWAY

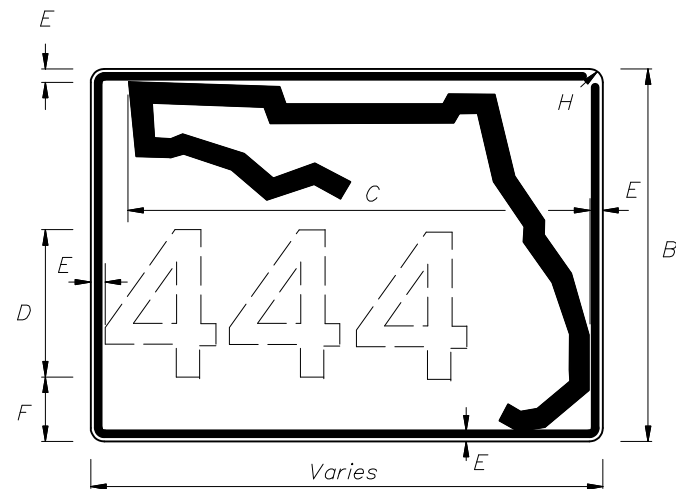

3 OR MORE DIGITS

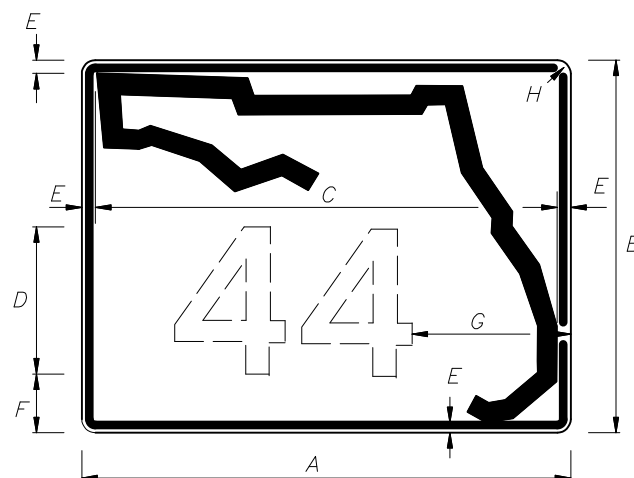

1 OR 2 DIGITS

SIGN	DIMENSIONS												**
	A	B	C	D	E	F	G	H	J	K	R	S	
4 DIGIT POST MOUNTED	25 1/8"	42"	3/4"	10"	4"	4"	8"	8"	8 3/8"	22"	5"	8 3/4"	
2 DIGIT OVERHEAD	21 1/2"	36"	1/2"	7 1/2"	3"	3"	12"	4 1/2"	7 1/8"	18 7/8"	4 1/4"	7 1/2"	42" x 42"
3 DIGIT OVERHEAD	25 1/8"	42"	3/4"	8"	4"	4"	12"	6"	8 3/8"	22"	5"	8 3/4"	48" x 48"
4 DIGIT OVERHEAD	29 7/8"	48"	3/4"	8"	5"	5"	12"	8"	9 3/4"	25 5/8"	5 3/4"	10 1/4"	52" x 52"

M1-6 COUNTY ROUTE MARKER DETAIL
FTP-18-06

A	B	C	D	E	F	G	H
30"	24"	26"	12"	1 1/4"	2 3/4"	8 1/4"	1 1/4"
36"	30"	32"	15"	1 1/4"	3 1/4"	8 3/4"	1 1/4"
42"	36"	38"	15"	1 1/4"	6 1/4"	11"	1 1/4"

GUIDE SIGN USE

- Notes:
- Florida marker shall have Black Legend with White Background.
 - Stroke width of State outline to be 1" for independent use and 1 1/4" for Guide Sign.
 - Numbers are series D.

FLORIDA ROUTE MARKER
FTP-17-06

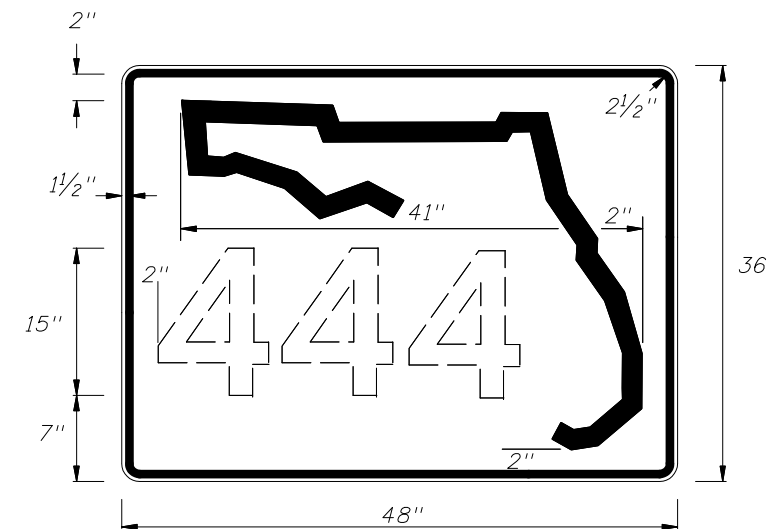

1-3 DIGITS 15" SERIES C
4 DIGITS 12" SERIES C
INDEPENDENT USE FOR FREEWAY



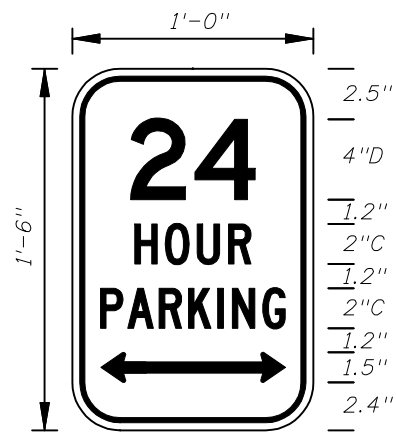

FTP-19-06
1' X 1'-6"
4" Radii 3/8" Border
Top 4" Series D
Bottom 2" Series C
White Background
Green Legend and Border

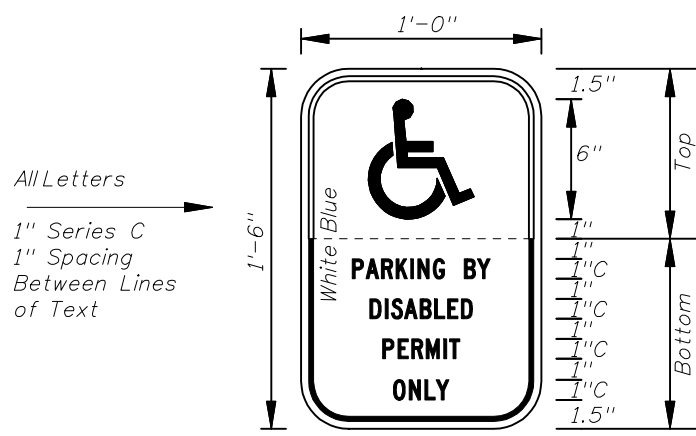

FTP-20-06
1' X 1'-6"
2" Radii 3/8" Border
1" Series C Legend
Color
Background
Legend and Border
Top Blue
Bottom White
White Black

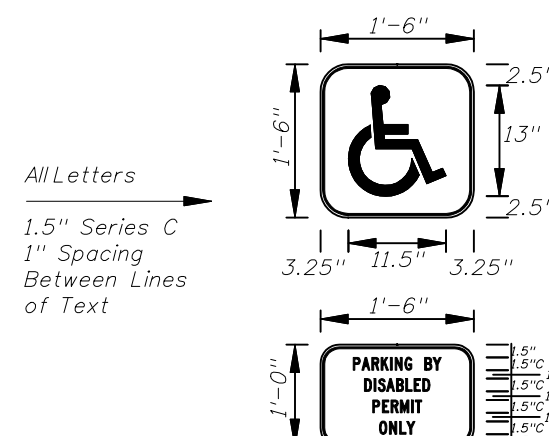

FTP-21-06
1'-6" X 2'-6"
2" Radii 3/8" Border
1.5" Series C Legend
Color
Background
Legend and Border
Top Blue
Bottom White
White Black

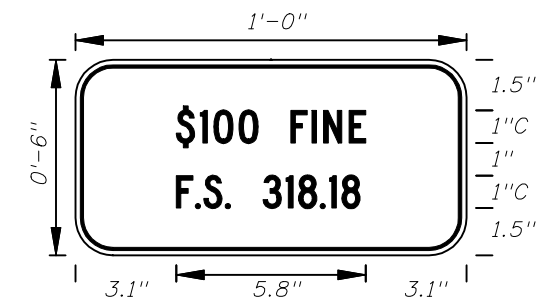

FTP-22-06
1' X 6"
1" Radii 3/8" Border
1" Series C Legend
White Background
Black Legend and Border
Supplemental panel
for the FTP-20-06
and FTP-21-06 signs

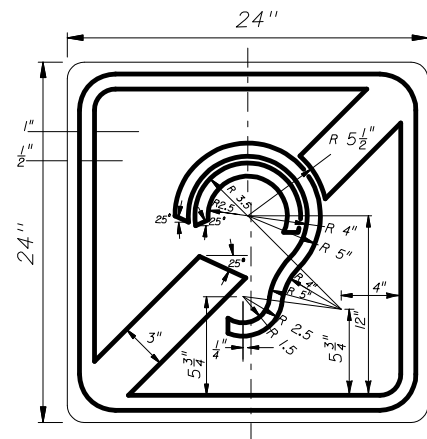

FTP-23-06
2' X 2'
1.5" Radii 5/8" Border
Blue Background
White Legend and Border

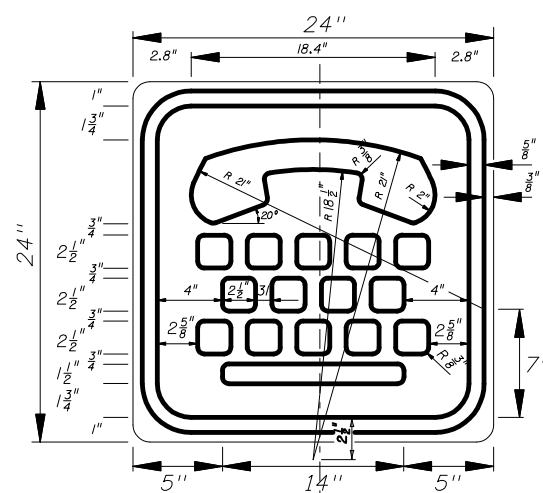

FTP-24-06
2' X 2'
1.5" Radii 5/8" Border
Blue Background
White Legend and Border

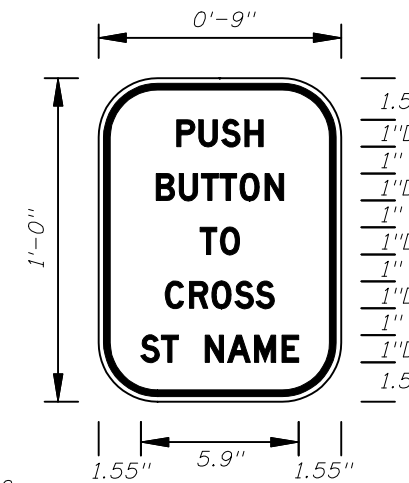

FTP-25-06
9" X 1'-0"
2" Radii 3/8" Border
1" Series D Legend
White Background
Black Legend and Border

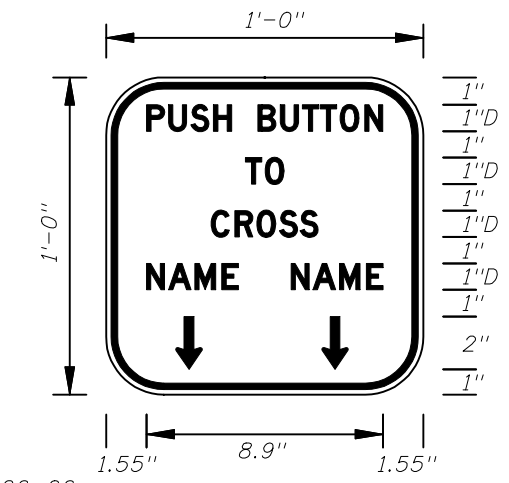

FTP-26-06
1' X 1'
2" Radii 3/8" Border
1" Series D Legend
White Background
Black Legend and Border

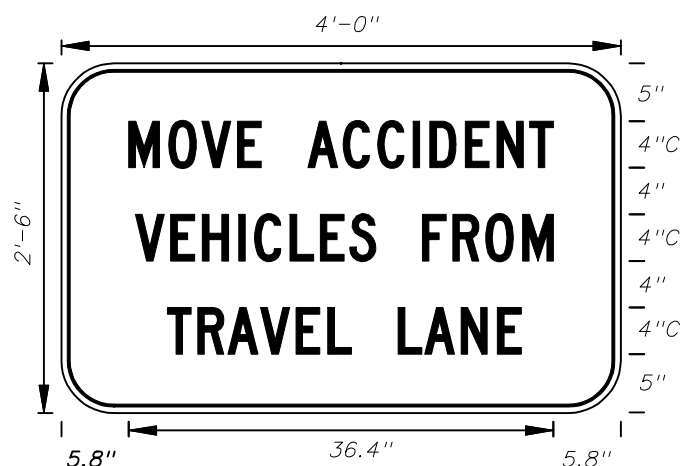

FTP-27-06
4' X 2'-6"
4" Radii 3/4" Border
4" Series C Legend
White Background
Black Legend and Border

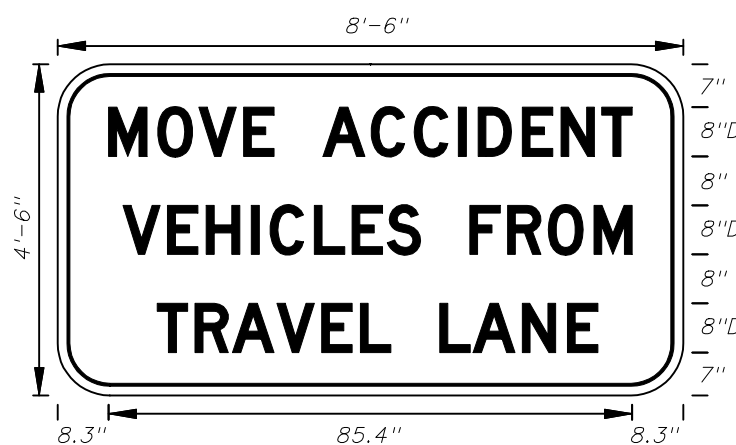

FTP-28-06
8'-6" X 4'-6"
7" Radii 3/4" Border
8" Series D Legend
White Background
Black Legend and Border

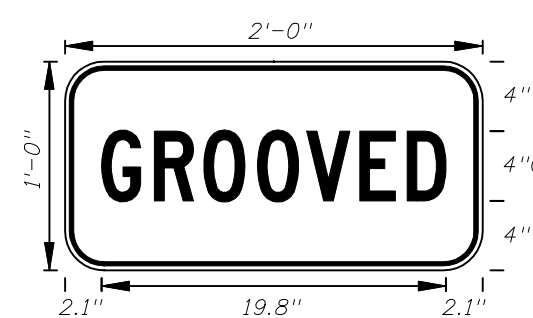

FTP-29-06
2'-0" X 1'-0"
2" Radii 5/8" Border
4" Series C Legend
Yellow Background
Black Legend and Border

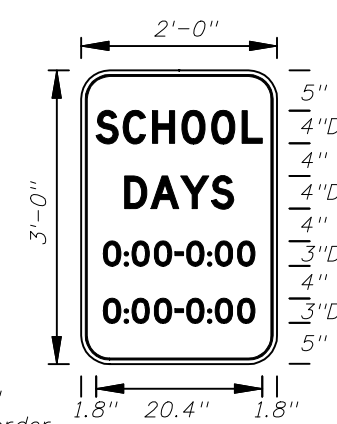

FTP-30-06
2'-0" X 3'-0"
3" Radii 5/8" Border
White Background
Black Legend and Border
Top 4" Series D Legend
Bottom 3" Series C Legend



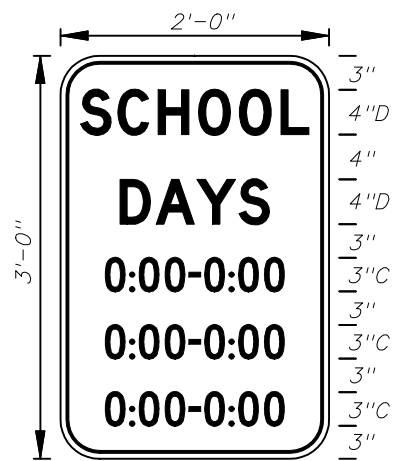

FTP-30A-06
2' X 3'
3" Radii 5/8" Border
Top 4" Series D Legend
Bottom 3" Series C Legend
White Background
Black Legend and Border

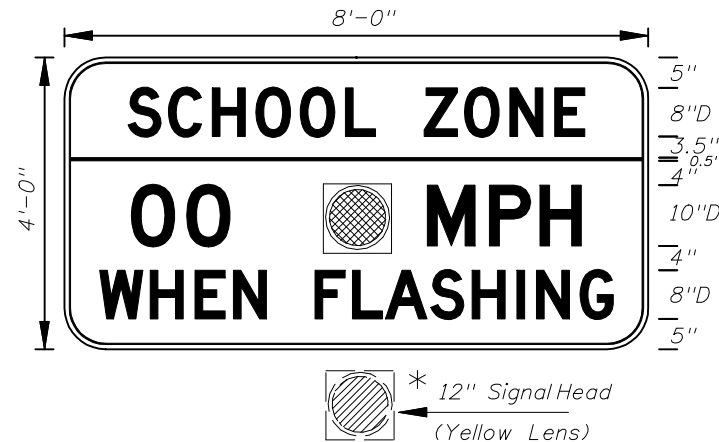

FTP-31-06
8' X 4'
6" Radii 3/4" Border
Series D Legend
Yellow Background Top
White Background Bottom
Black Legend and Border

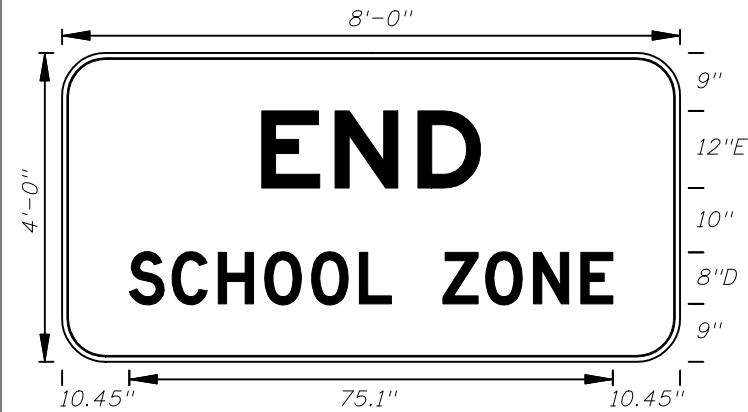

FTP-32-06
8' X 4'
6" Radii 3/4" Border
12" Series E and 8" Series D Legend
White Background
Black Legend and Border

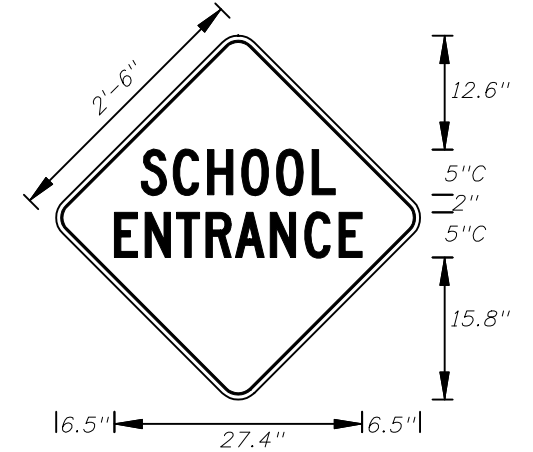

FTP-33-06
2'-6" X 2'-6"
2" Radii 3/4" Border
5" Series C Legend
Yellow Background
Black Legend and Border

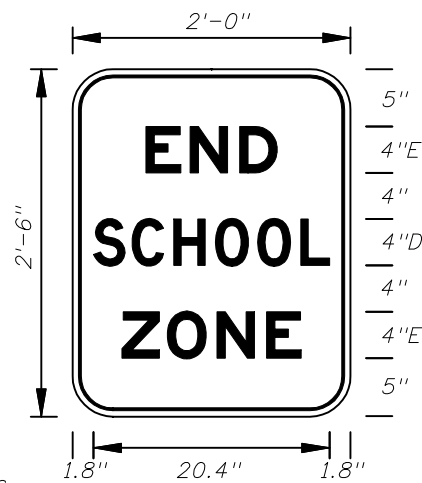

FTP-34-06
2' X 2'-6"
3" Radii 5/8" Border
4" Series D and E Legend
White Background
Black Legend and Border

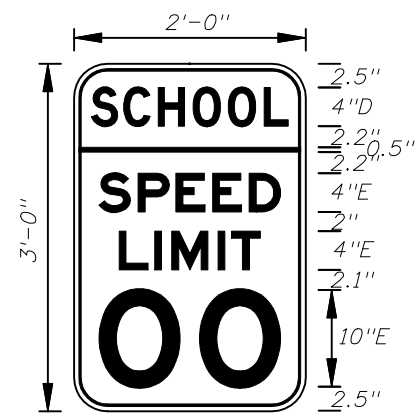

FTP-35-06
2' X 3'
3" Radii 5/8" Border
Top 4" Series D Legend
Bottom 4" and 10" Series E Legend
Yellow Background Top White Background Bottom
Black Legend and Border

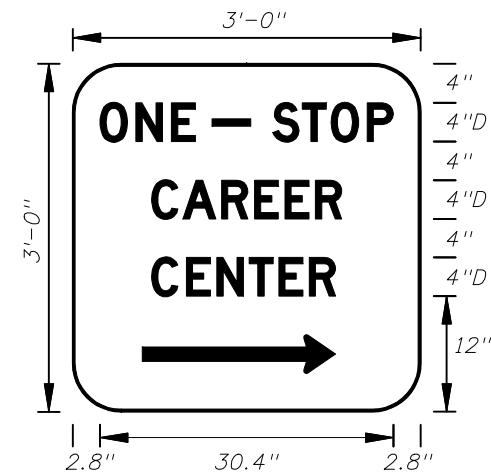

FTP-36-06
3' X 3'
5" Radii
4" Series D Legend
Green Background
White Legend and Border

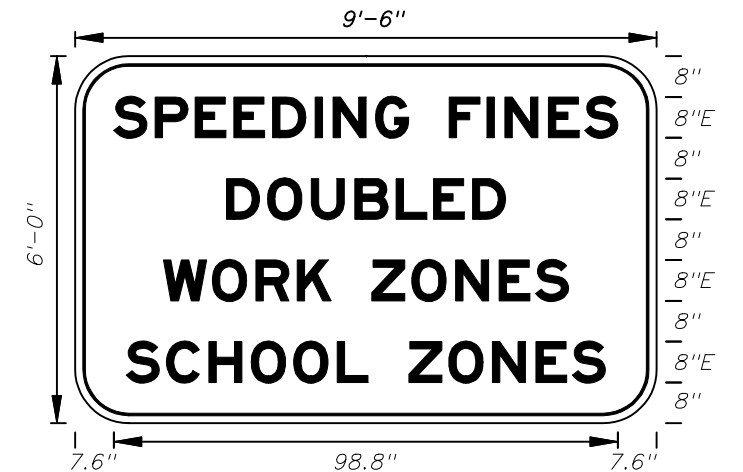

FTP-37-06
9'-6" X 6'
9" Radii 2" Border
8" Series E Legend
White Background
Black Legend and Border
State Line Sign

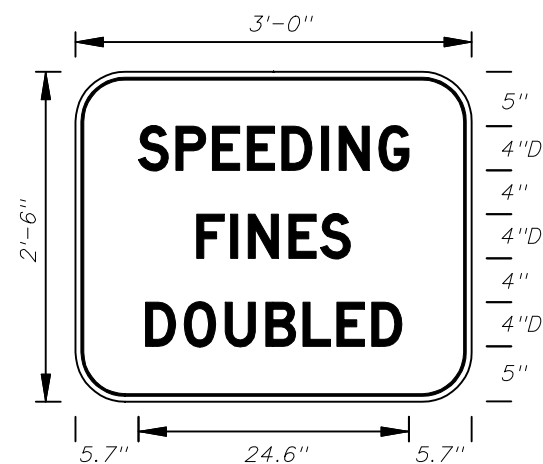

FTP-38-06
3' X 2'-6"
4" Radii 3/4" Border
4" Series D Legend
White Background
Black Legend and Border

Arterial Sign

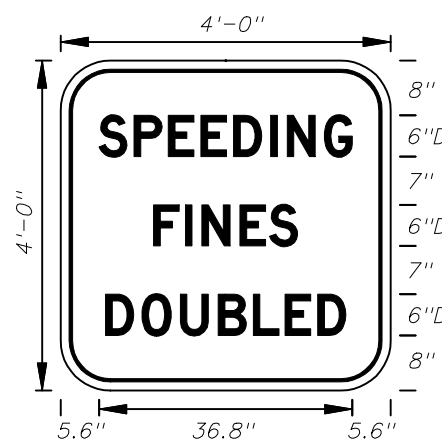

FTP-39-06
4' X 4'
6" Radii 3/4" Border
6" Series D Legend
White Background
Black Legend and Border

Freeway Sign

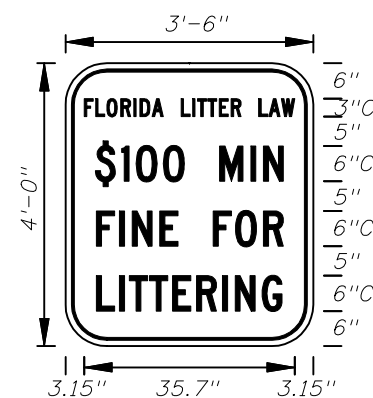

FTP-40-06
3'-6" X 4'
6" Radii 3/4" Border
3" and 6" Series C Legend
White Background
Black Legend and Border

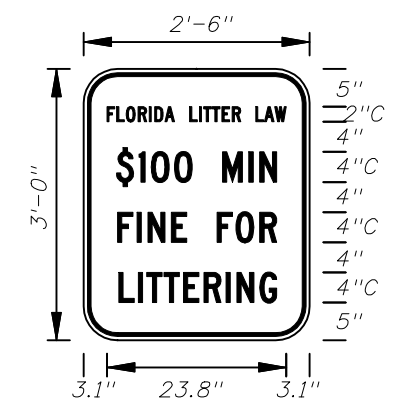

FTP-41-06
2'-6" X 3'
4" Radii 3/4" Border
2" and 4" Series C Legend
White Background
Black Legend and Border

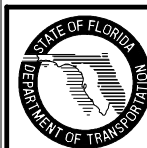

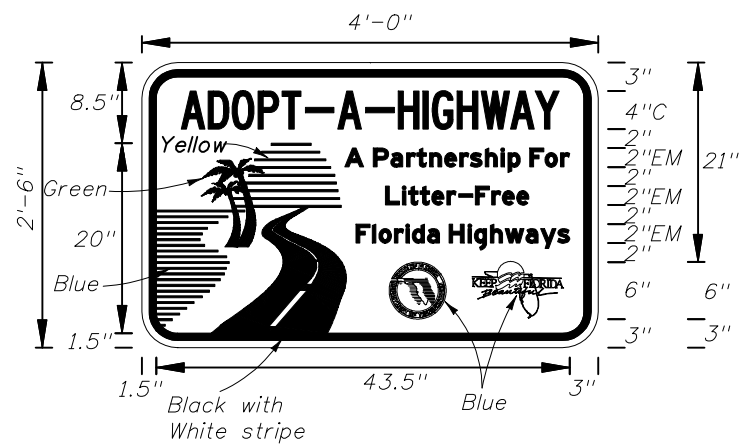

FTP-42-06
4' X 2'-6"
3" Radii
Top 4" Series C Legend
Bottom 2" Series EM Legend
White Background
Blue Legend and Border

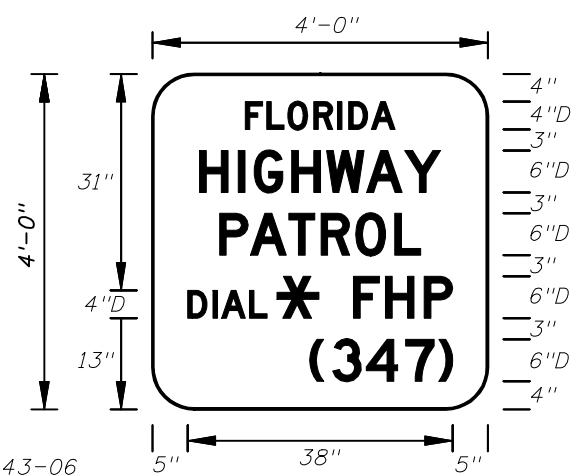

FTP-43-06
4' X 4'
6" Radii 1" Border
Top 4" Series D Legend
Bottom 6" Series D Legend
Blue Background
White Legend and Border



FTP-44-06
9' X 6'
9" Radii 3/4" Border
8" Series D Legend
White Background
Black Legend and Border



FTP-45-06
4' X 3'
5" Radii 3/4" Border
4" Series C Legend
White Background
Black Legend and Border

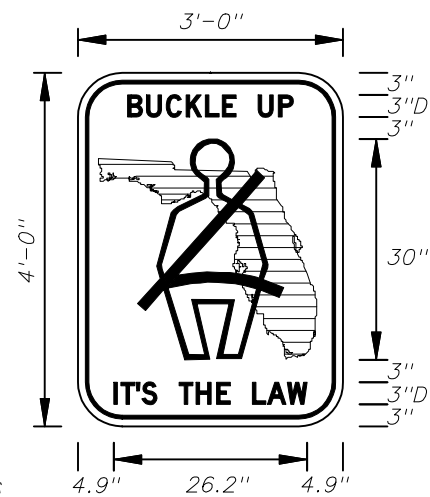

FTP-46-06
3' X 4'
5" Radii 3/4" Border
3" Series D Legend
White Background Florida Shield Green
Black Legend, Border and Man Belt Symbol

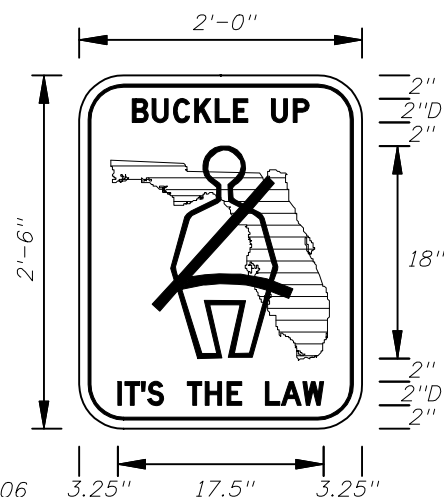

FTP-47-06
2' X 2'-6"
3" Radii 5/8" Border
2" Series D Legend
White Background Florida Shield Green
Black Legend, Border and Man Belt Symbol

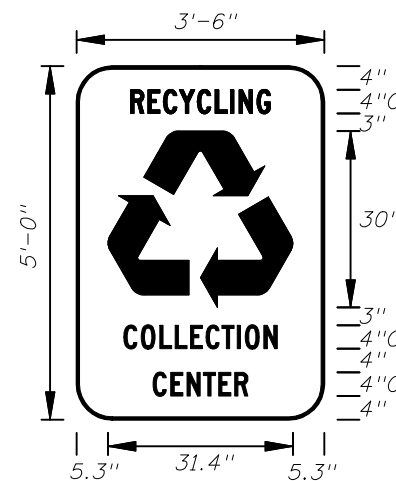

FTP-48-06
3'-6" X 5'
6" Radii
4" Series C Legend
Green Background
White Legend, Border and Symbol

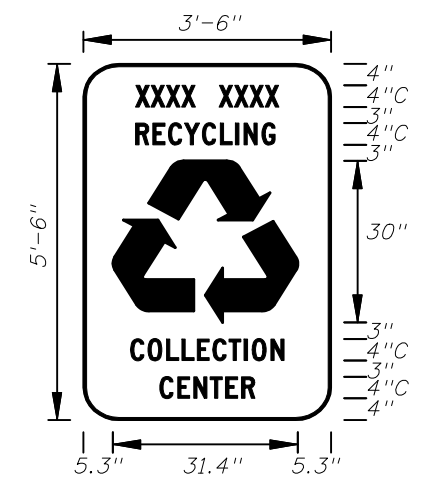

FTP-49-06
3'-6" X 5'-6"
6" Radii
4" Series C Legend
Green Background Municipality Name Optional
White Legend, Border and Symbol

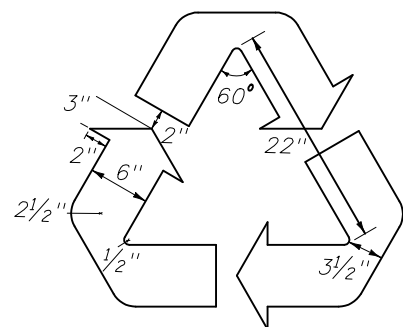

Detail for FTP-48-06 and FTP-49-06

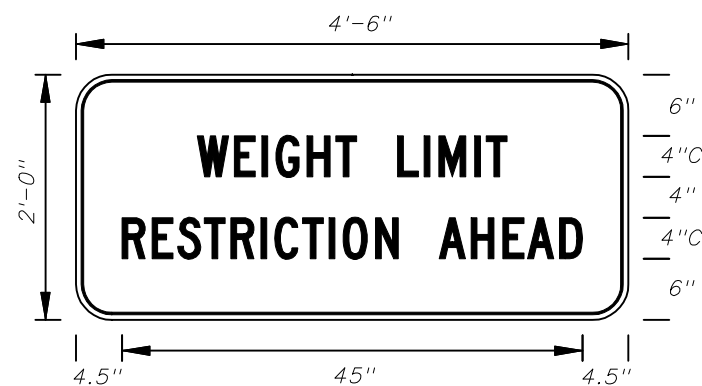

FTP-50-06
4'-6" X 2'
3" Radii 3/4" Border
4" Series C Legend
Yellow Background
Black Legend and Border

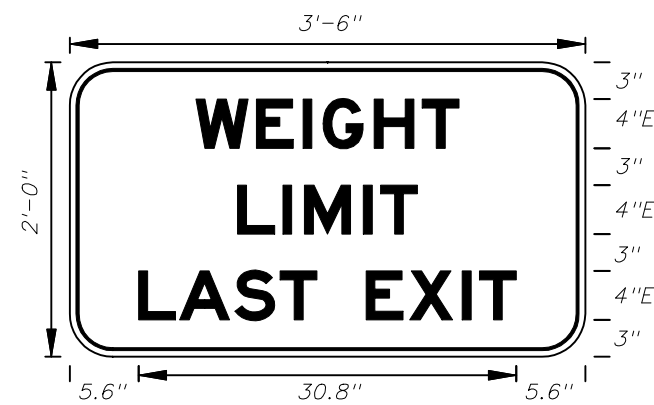

FTP-51-06
3' X 2'
3" Radii 3/4" Border
4" Series E Legend
White Background
Black Legend and Border

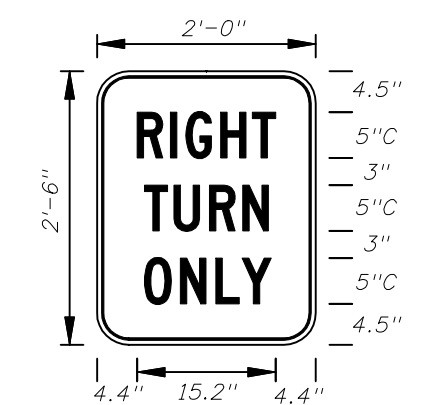

FTP-52-06
2' X 2'-6"
3" Radii 5/8" Border
5" Series C Legend
White Background
Black Legend and Border



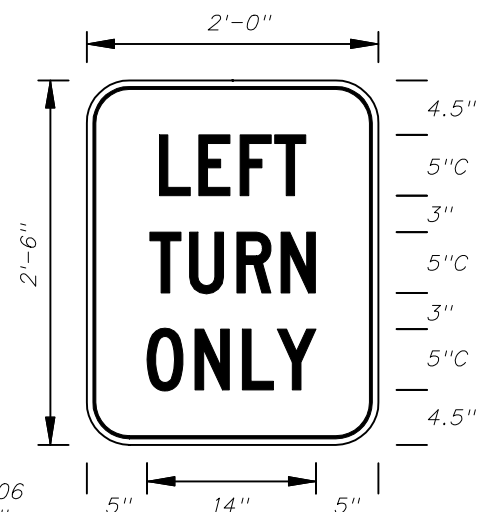

FTP-53-06
2' X 2'-6"
3" Radii 5/8" Border
5" Series C Legend
White Background
Black Legend and Border

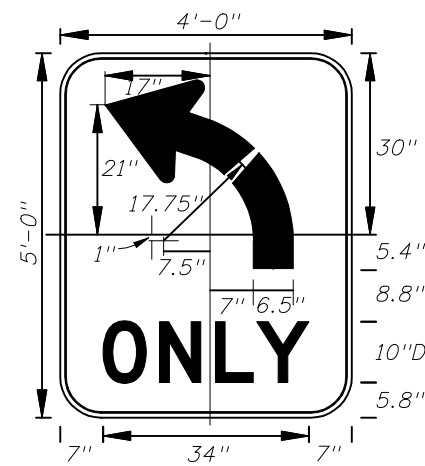

FTP-54-06
4' X 5'
6" Radii 3/4" Border
10" Series D Legend
White Background
Black Legend and Border

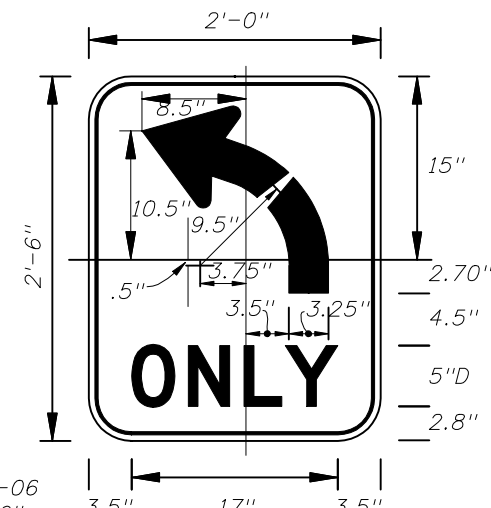

FTP-55-06
2' X 2'-6"
3" Radii 3/8" Border
5" Series D Legend
White Background
Black Legend and Border

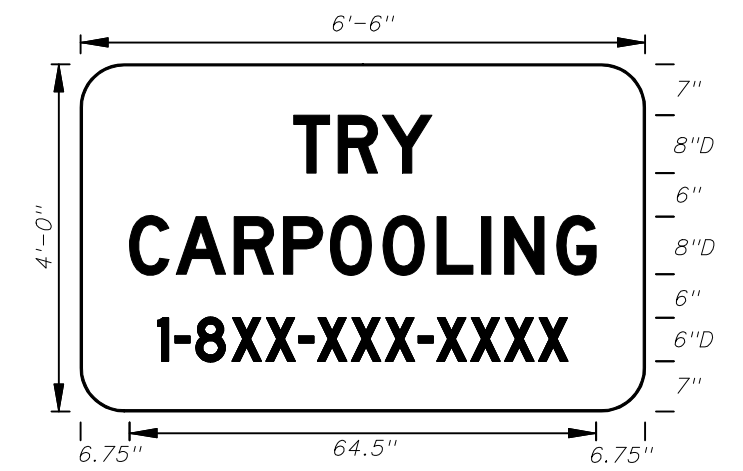

FTP-56-06
6'-6" X 4'
6" Radii 3/4" Border
8" and 6" Series D Legend
Blue Background
White Legend and Border

Design Project Manager
or Transit Administrator
will supply correct 1-8XX
number.

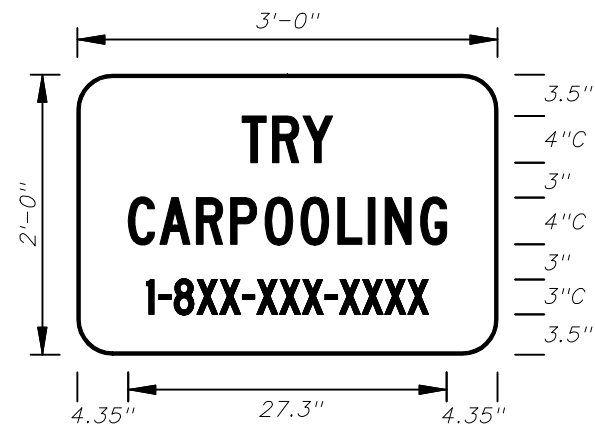

FTP-56A-06
3' X 2'
3" Radii
4" and 3" Series C Legend
Blue Background
White Legend and Border

Design Project Manager
or Transit Administrator
will supply correct 1-8XX
number.

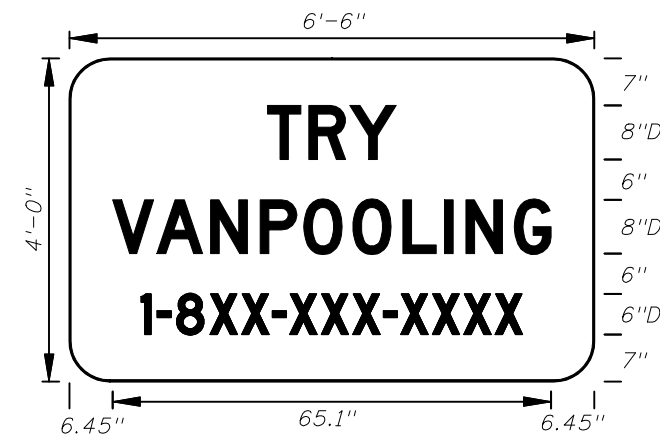

FTP-57-06
6'-6" X 4'
6" Radii
8" and 6" Series D Legend
Blue Background
White Legend and Border

Design Project Manager
or Transit Administrator
will supply correct 1-8XX
number.

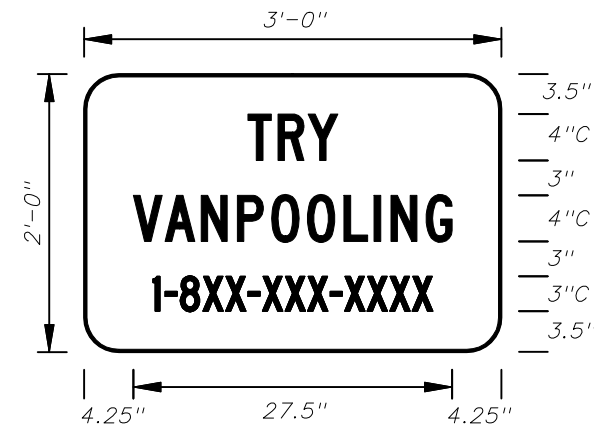

FTP-58-06
3' X 2'
3" Radii
4" and 3" Series C Legend
Blue Background
White Legend and Border

Design Project Manager
or Transit Administrator
will supply correct 1-8XX
number.

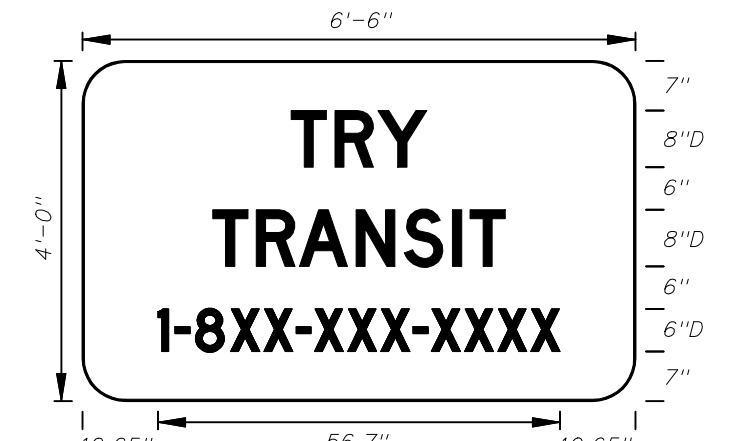

FTP-59-06
6'-6" X 4'
6" Radii
8" and 6" Series D Legend
Blue Background
White Legend and Border

Design Project Manager
or Transit Administrator
will supply correct 1-8XX
number.

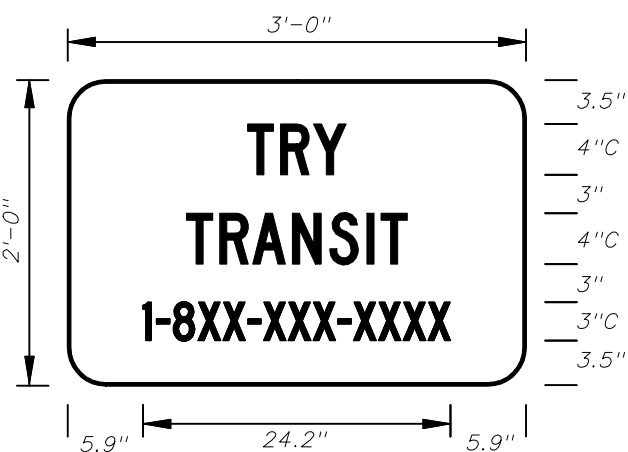

FTP-60-06
3' X 2'
3" Radii
4" and 3" Series C Legend
Blue Background
White Legend and Border

Design Project Manager
or Transit Administrator
will supply correct 1-8XX
number.



FTP-61-06
3' X 2'
3" Radii 3/4" Border
4" and 3" Series C Legend
Yellow Background
Black Legend and Border

Design Project Manager
or Transit Administrator
will supply correct 1-8XX
number.

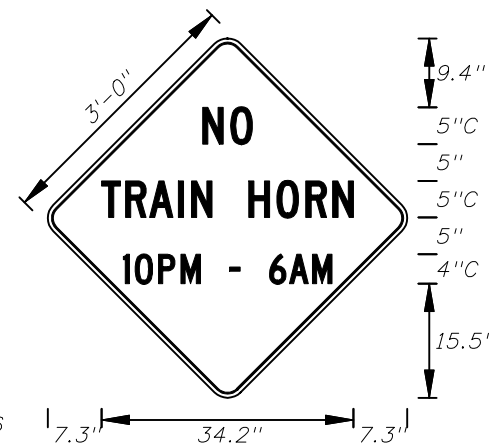

FTP-62-06
3' X 3'
2" Radii 3/4" Border 4" and 5" Series C Legend
Yellow Background Black Legend and Border

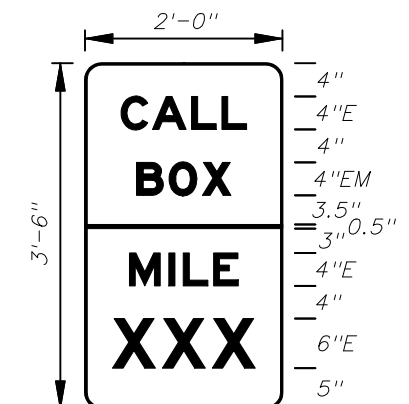

FTP-63-06
2' X 3'-6"
2" Radii 4" and 6" Series E and EM Legend
Top Blue Background White Legend and Border
Bottom Green Background White Legend and Border



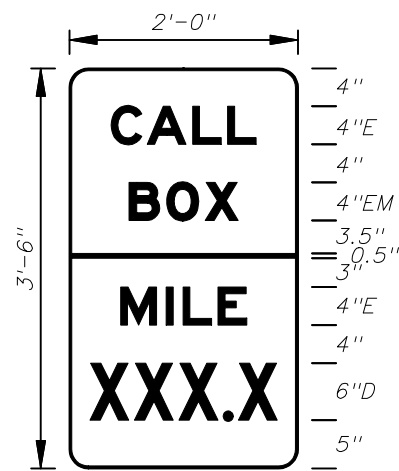

FTP-64-06
2' X 3'-6"
2" Radii
Top 4" Series E and 4" Series EM Legend
Blue Background White Legend and Border
Bottom 4" Series E and 6" Series D Legend
Green Background White Legend and Border

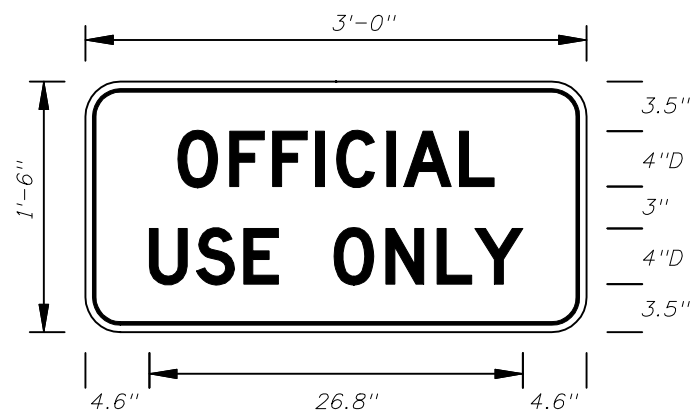

FTP-65-06
3' X 1'-6"
2" Radii 3/4" Border
4" Series D Legend
White Background
Black Legend and Border



FTP-66-06
4' X 5'
2" Radii 3/4" Border
7" Series D Legend
Blue Background
White Legend and Border



FTP-67-06
3' X 4'
2" Radii 3/4" Border
5" Series D Legend
Blue Background
White Legend and Border

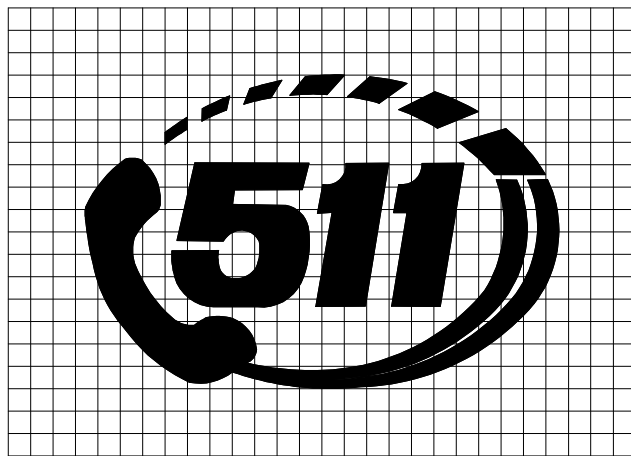

DETAIL for FTP-66 AND FTP-67

Sign Mounting Holes Can Be Punched Or Field Drilled With No Obstruction To Text Or Symbols From Holes Or Bolts.

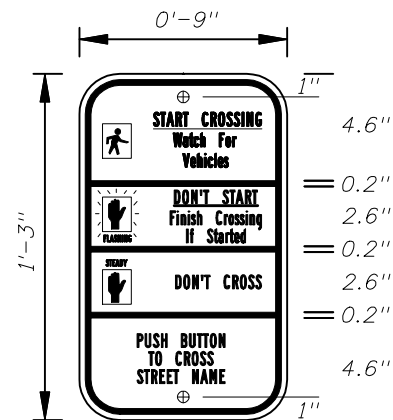

FTP-68A-06
9" X 1'-3"
1.5" Radii 3/4" Border
Series B Legend
White Background
Black Legend and Border

See Standard Highway Signs Manual, Sign R10-3b For Letter Size Spacing And Symbol Sizes.

Sign Mounting Holes Can Be Punched Or Field Drilled With No Obstruction To Text Or Symbols From Holes Or Bolts.

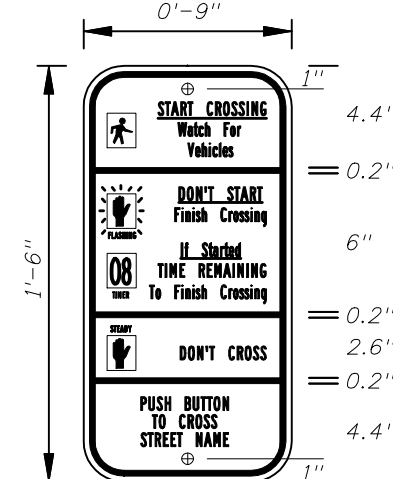

FTP-68B-06
9" X 1'-6"
1.5" Radii 3/4" Border
Series B Legend
White Background
Black Legend and Border

See Standard Highway Signs Manual, Sign R10-3b For Letter Size Spacing And Symbol Sizes.

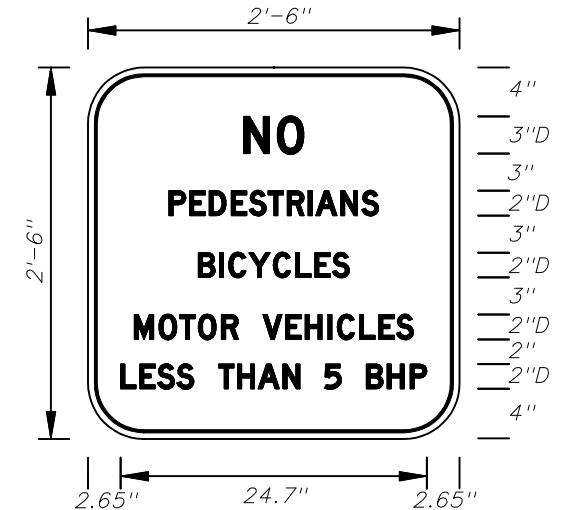

FTP-69-06
2'-6" X 2'-6"
4" Radii 3/4" Border
2" and 3" Series D Legend
White Background
Black Legend and Border

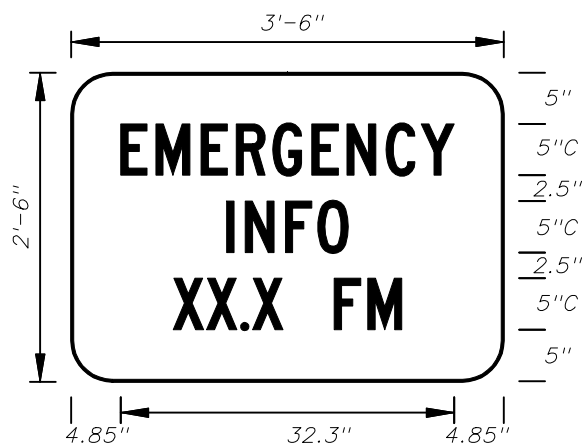

FTP-70-06
3'-6" X 2'-6"
4" Radii 3/4" Border
5" Series C Legend
Blue Background
White Legend and Border

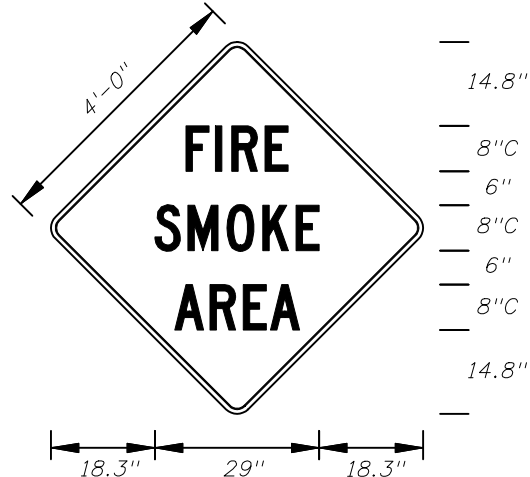

FTP-71-06
4' X 4'
2" Radii 3/4" Border
8" Series C Legend
Yellow Background
Black Legend and Border



FTP-72-06
3' X 3'
2" Radii 3/4" Border
6" Series C Legend
Yellow Background
Black Legend and Border

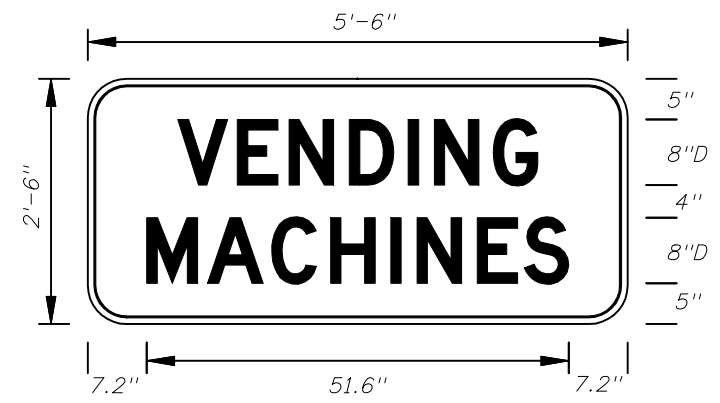

FTP-73-06
5'-6" X 2'-6"
4" Radii 3/4" Border
8" Series D Legend
Blue Background
White Legend and Border





FTP-74-06
5'-6" X 2'-6"
4" Radii 3/4" Border
6" Series D Legend
Blue Background
White Legend and Border

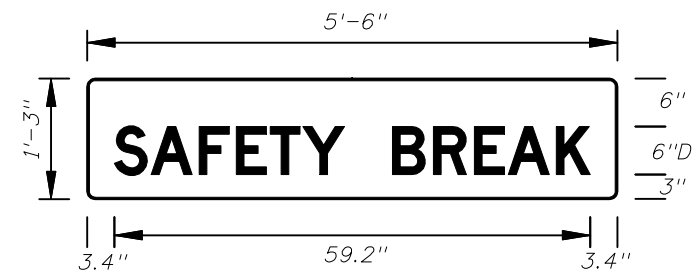

FTP-75-06
5'-6" X 1'-3"
1" Radii
6" Series D Legend
Blue Background
White Legend

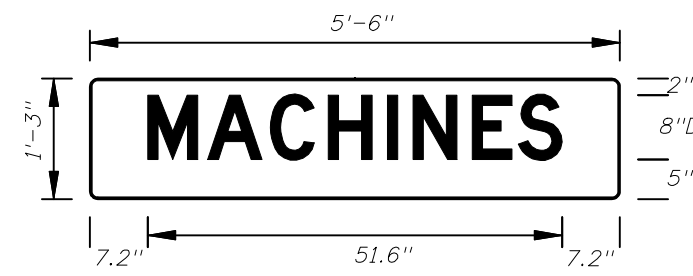

FTP-76-06
5'-6" X 1'-3"
1" Radii
8" Series D Legend
Blue Background
White Legend

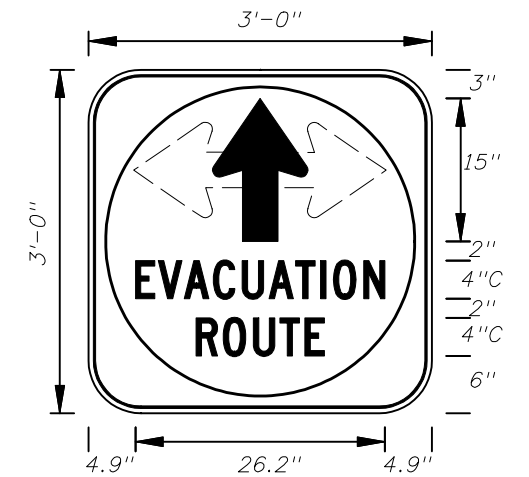

FTP-77-06
3' X 3'
5" Radii 3/4" Border
4" Series C Legend
White Background with Blue Circle Background
White Legend and Black Border

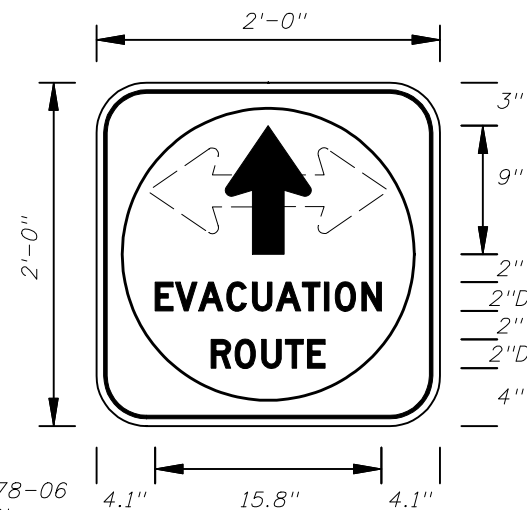

FTP-78-06
2' X 2'
3" Radii 3/4" Border
2" Series D Legend
White Background with Blue Circle Background
White Legend and Black Border

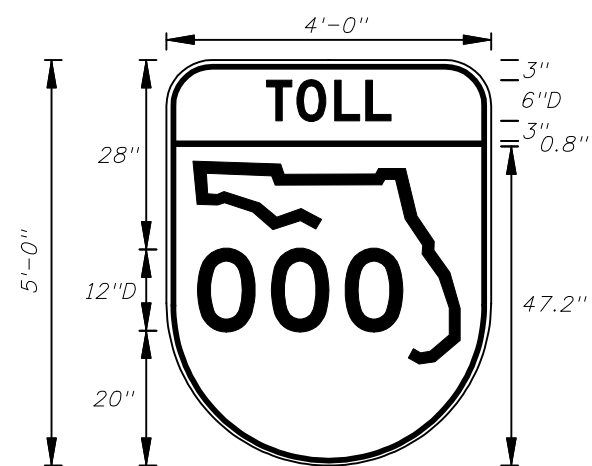

FTP-79-06
4' X 5'
6" Radii 3/4" Border
6" and 12" Series D Legend
Top Green Background with White Legend and Black Border
Bottom White Background with Black Legend and Border

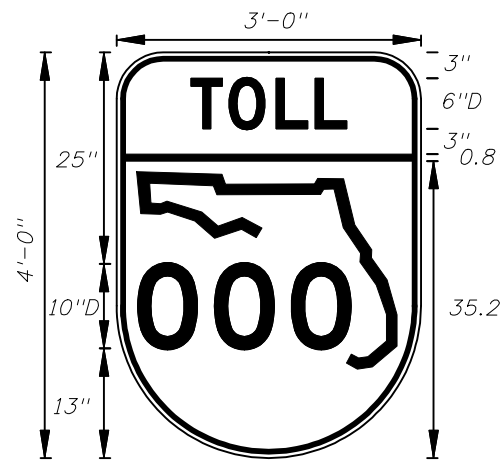

FTP-80-06
3' X 4'
5" Radii 3/4" Border
6" and 10" Series D Legend
Top Green Background with White Legend and Black Border
Bottom White Background with Black Legend and Border

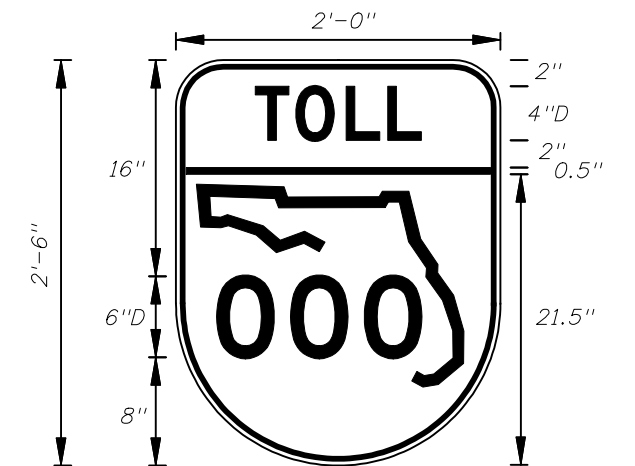

FTP-81-06
2' X 2'-6"
3" Radii 3/4" Border
4" and 6" Series D Legend
Top Green Background with White Legend and Black Border
Bottom White Background with Black Legend and Border

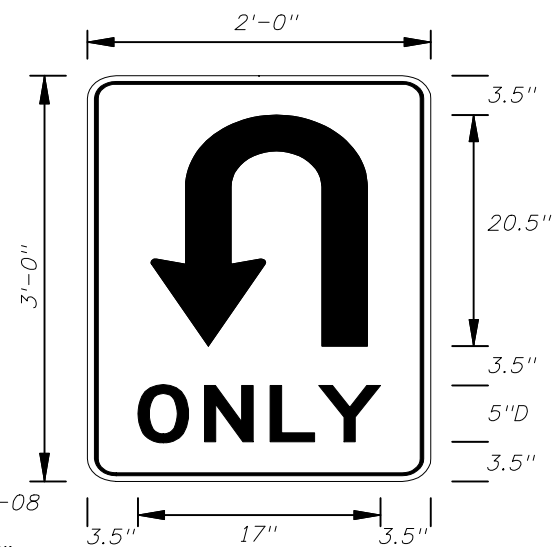

FTP-82-08
2' X 3'
1.5" Radii
5" Series D Legend
White Background
Black Legend and Border

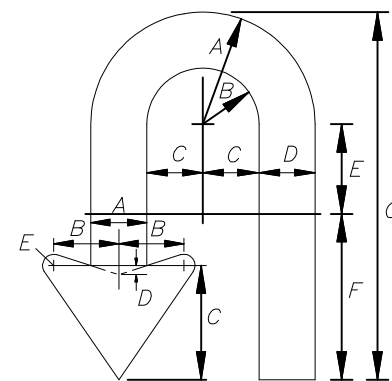

ARROW BODY

A	B	C	D	E	F	G
6.25	3.125	3.125	3.125	5	9.25	20.5

ARROW HEAD

A	B	C	D	E
3.125	3.625	6.375	.5	.625

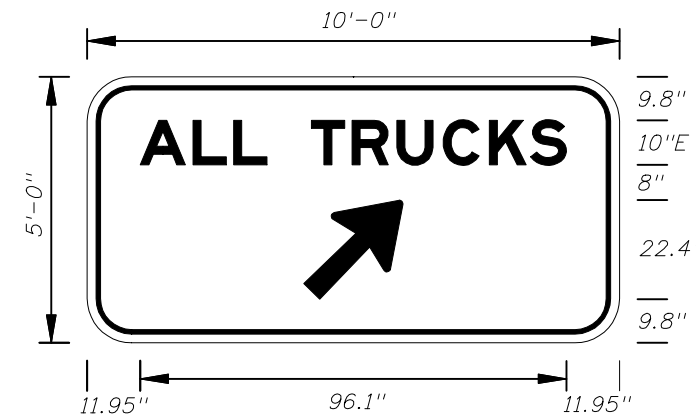

FTP-83-08
10'-0" X 5'-0"
8" Radii
10" Series E Legend
Green Background
White Legend



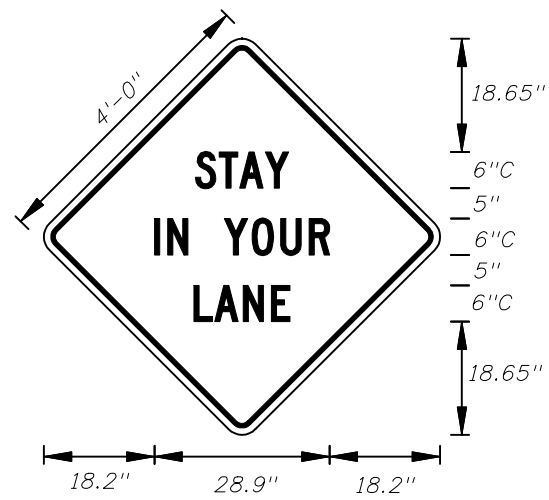

MDT-1-06
4' X 4'
2" Radii 3/4" Border
6" Series C Legend
Orange Background
Black Legend and Border

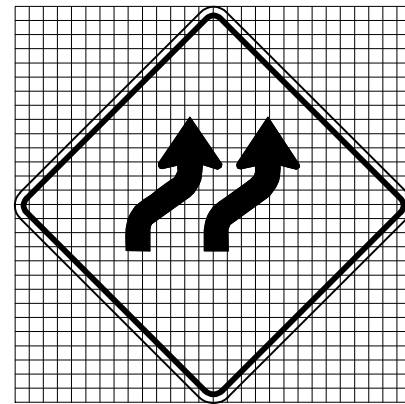

MDT-2-06
4' X 4'
2" Radii 3/4" Border
Orange Background
Black Arrows and Border

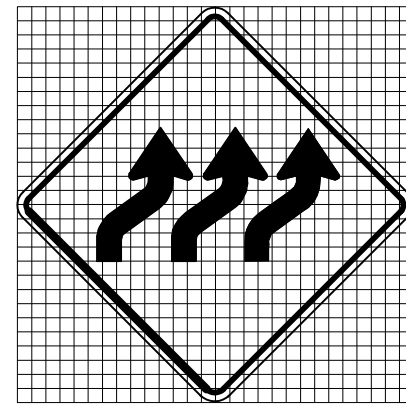

MDT-3-06
4' X 4'
2" Radii 3/4" Border
Orange Background
Black Arrows and Border

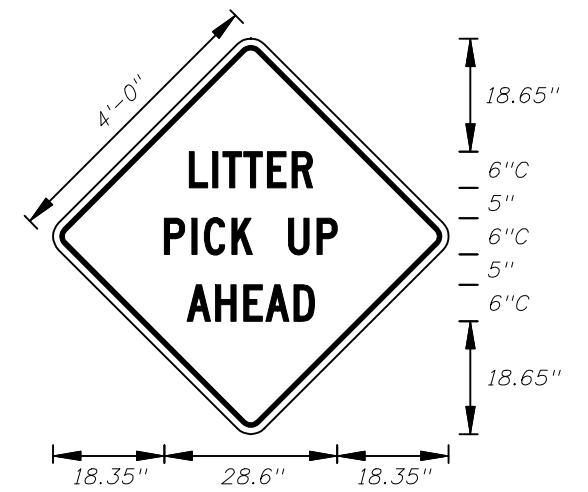

MDT-4-06
4' X 4'
2" Radii 3/4" Border
6" Series C Legend
Orange Background
Black Legend and Border

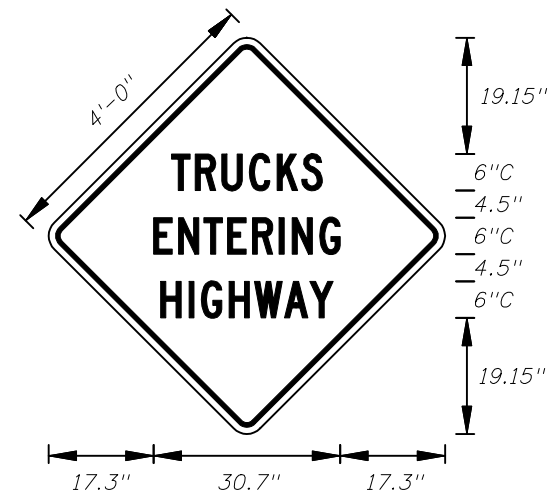

MDT-5-06
4' X 4'
2" Radii 3/4" Border
6" Series C Legend
Orange Background
Black Legend and Border

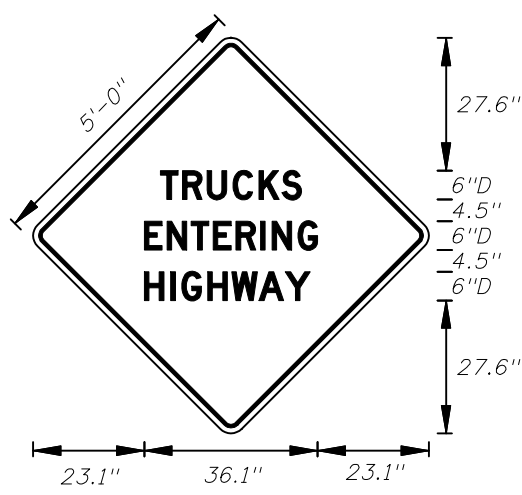

MDT-6-06
5' X 5'
2" Radii 3/4" Border
6" Series D Legend
Orange Background
Black Legend and Border

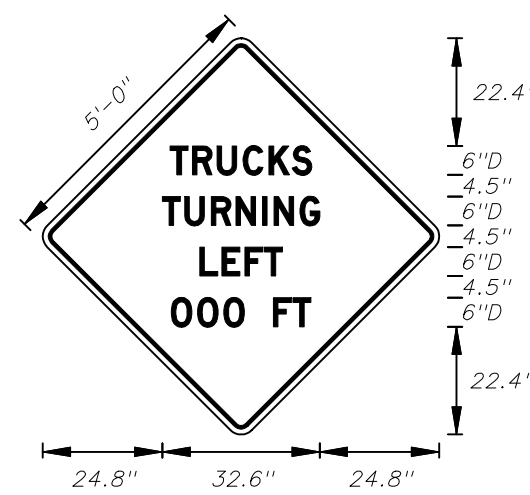

MDT-7-06
5' X 5'
2" Radii 3/4" Border
6" Series D Legend
Orange Background
Black Legend and Border

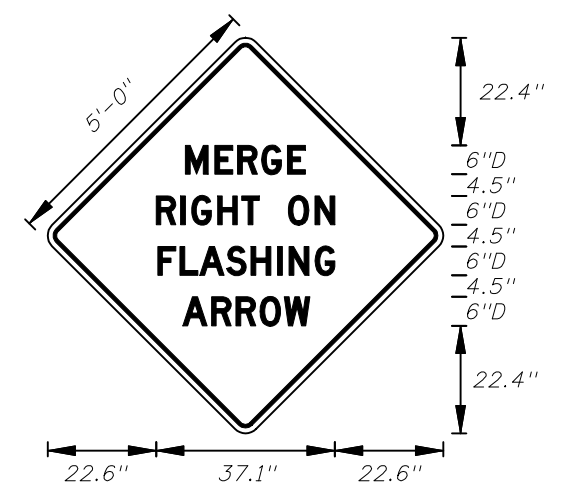

MDT-8-06
5' X 5'
2" Radii 3/4" Border
6" Series D Legend
Orange Background
Black Legend and Border

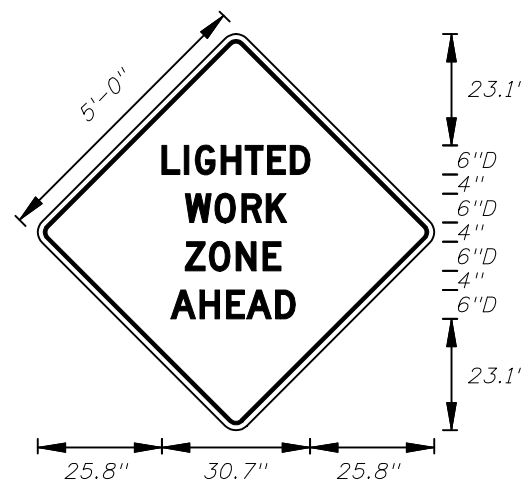

MDT-9-06
5' X 5'
2" Radii 3/4" Border
6" Series D Legend
Orange Background
Black Legend and Border

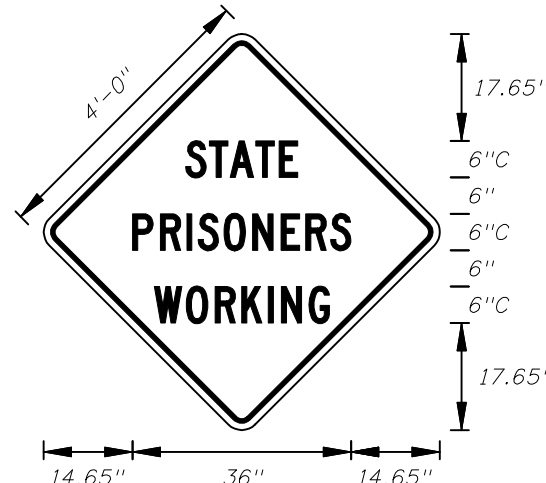

MDT-10-06
4' X 4'
2" Radii 3/4" Border
6" Series C Legend
Orange Background
Black Legend and Border

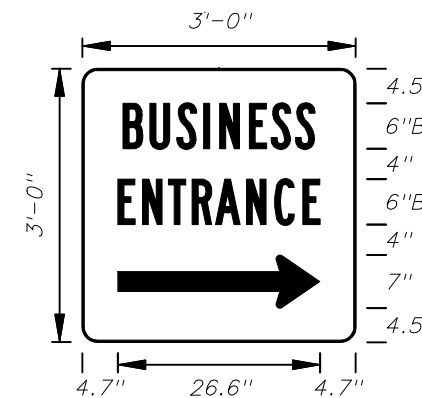

MDT-11-06
3' X 3'
2" Radii 3/4" Border
6" Series B Legend
Blue Background
White Legend and Border

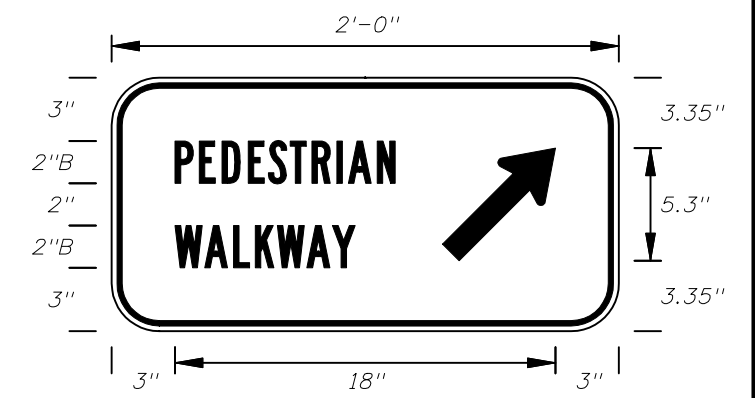

MDT-12-06
2' X 1'
2" Radii 3/4" Border
2" Series B Legend
White Background
Black Legend and Border



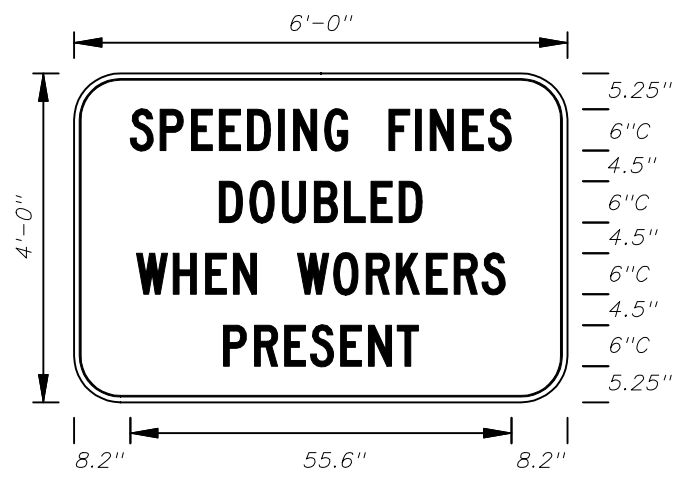

MDT-13-06 Freeway Sign
6' X 4'
6" Radii $\frac{3}{4}$ " Border

6" Series C Legend
White Background
Black Legend and Border

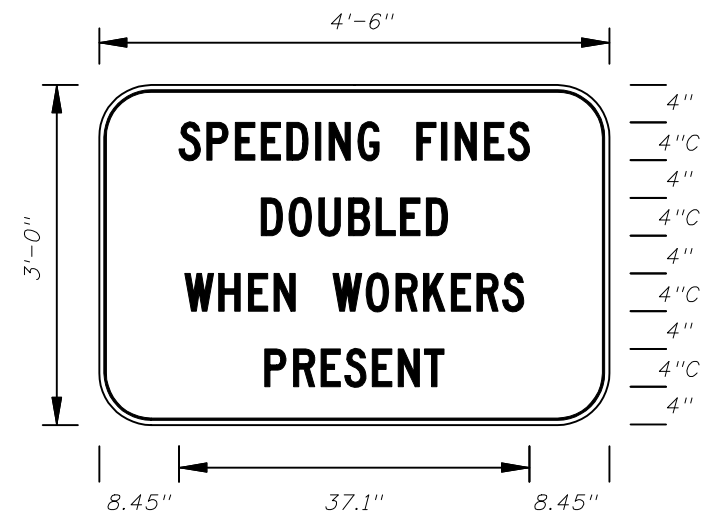

MDT-14-06 Arterial Sign
4'-6" X 3'
5" Radii $\frac{3}{4}$ " Border

4" Series C Legend
White Background
Black Legend and Border

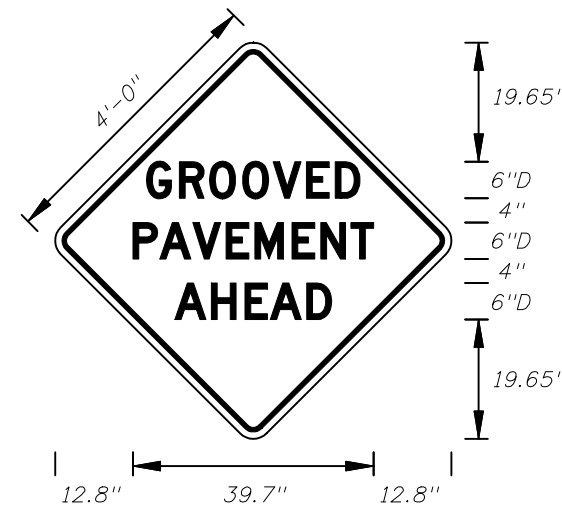

MDT-15-06
4' X 4'
2" Radii $\frac{3}{4}$ " Border

6" Series D Legend
Orange Background
Black Legend and Border

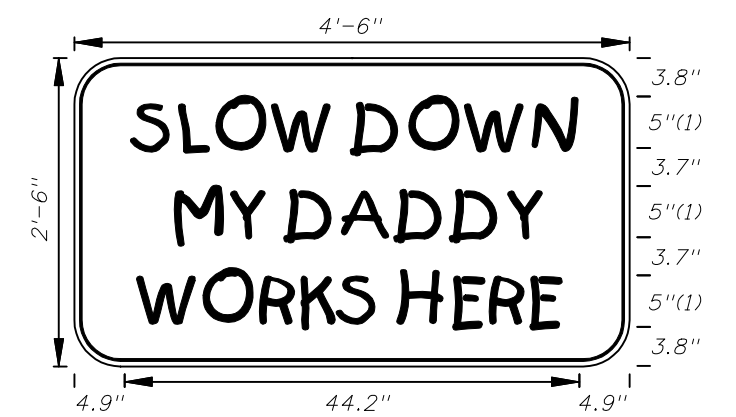

MDT-16-06
4'-6" X 2'-6"
4" Radii $\frac{3}{4}$ " Border

5" Kids Series Legend
Orange Background
Black Legend and Border

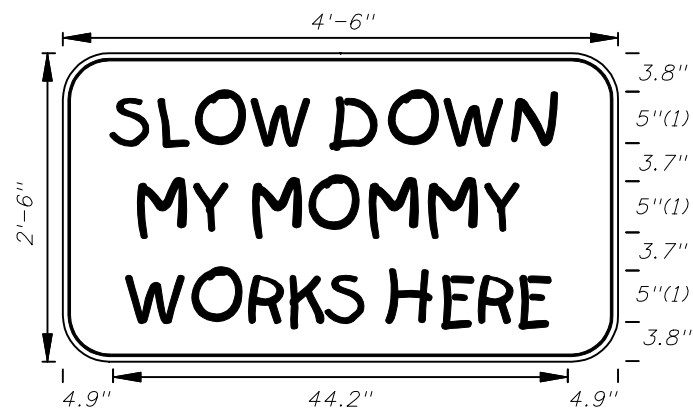

MDT-17-06
4'-6" X 2'-6"
4" Radii $\frac{3}{4}$ " Border

5" Kids Series Legend
Orange Background
Black Legend and Border



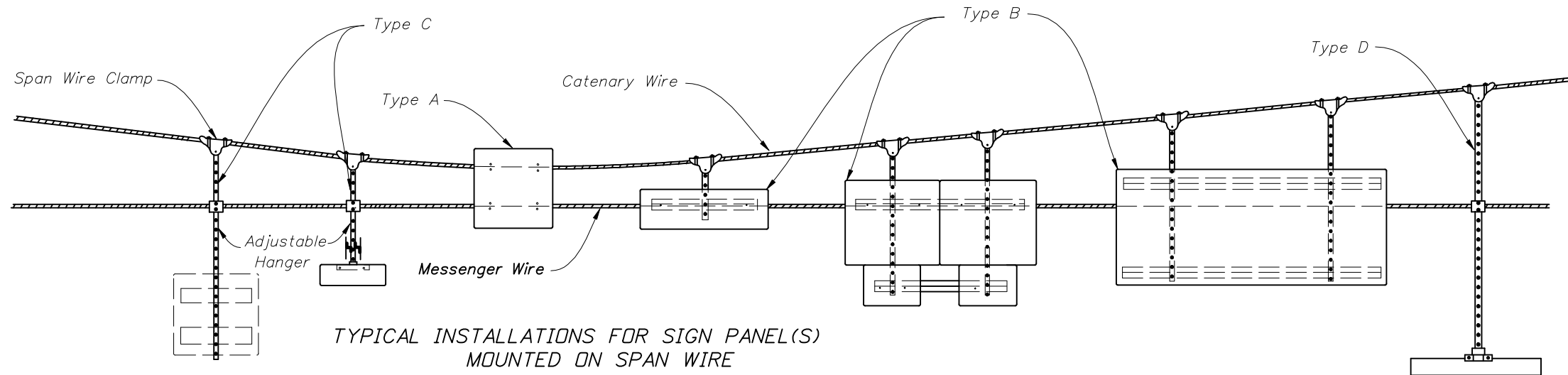

Notes :

1. Bottom edge of signs shall be approximately at the same elevation.
2. Type B & C attachments with one hanger shall have wind beams for signs wider than 3½'. The beams shall extend to within 6" of the sign edge.
3. Type B & C attachments for signs 4' and wider shall have 2 hangers. Signs 7' and wider shall have wind beams that extend to within 6" of the sign edge.
4. Type D attachments shall be for signs 3½' wide or less.
5. Sign panels shall meet the requirements of Index 11200.
6. Refer to section 634 of the Standard Specifications For Road And Bridge Construction.
7. All bolts, nuts, and washers shall be passivated stainless steel, AISI 300 series, commercial grade, type 316.

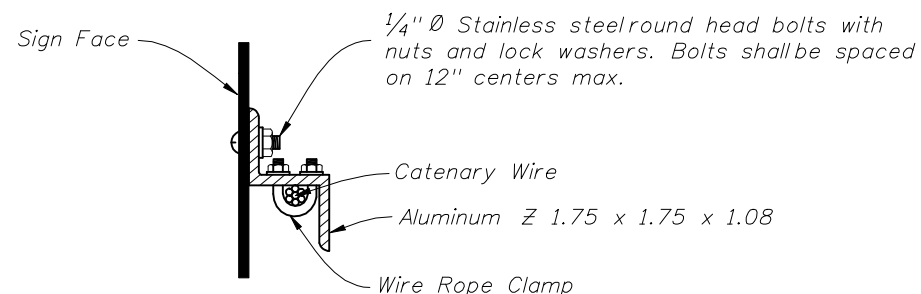

SIGN MOUNTING DETAIL

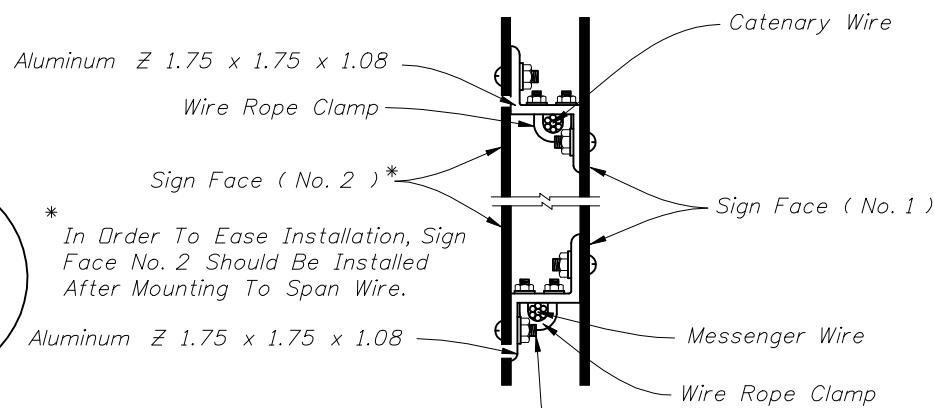

* In Order To Ease Installation, Sign Face No. 2 Should Be Installed After Mounting To Span Wire.

The overlapped connection of adjustable hangers shall use a minimum of 2 bolts with a minimum spacing between bolts of 2".

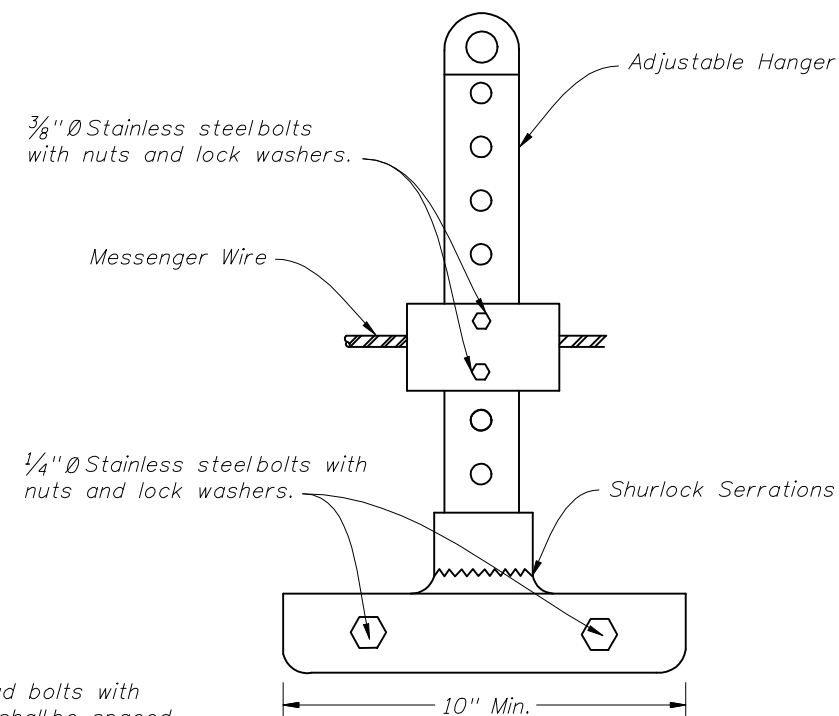

ADJUSTABLE HANGER FOR SIGN MOUNTING

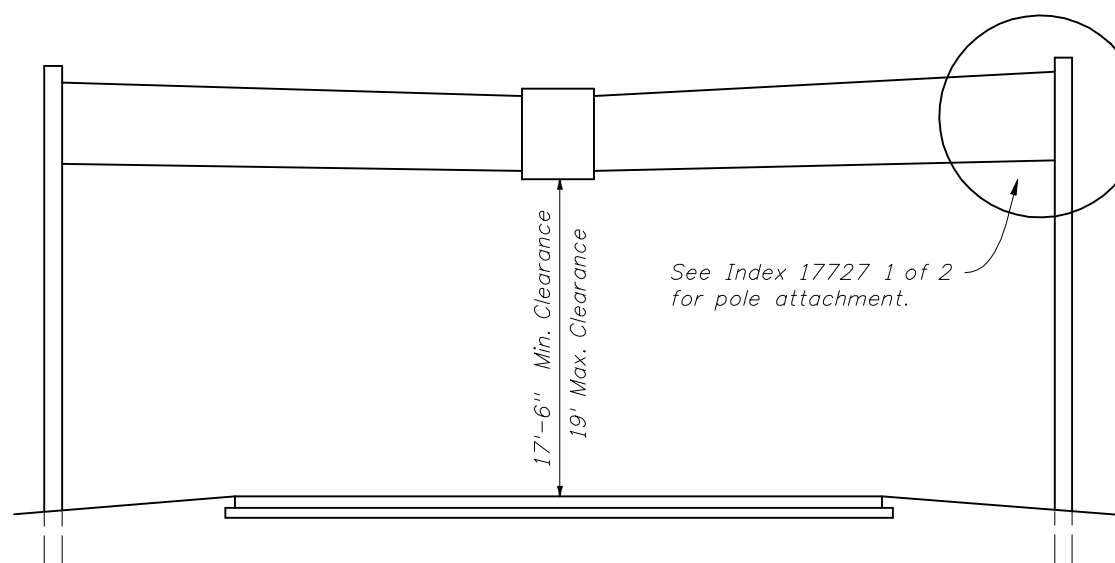

TYPICAL SPAN WIRE INSTALLATION

See Index 17727 1 of 2 for pole attachment.

TWO POINT ATTACHMENT



2010 FDOT Design Standards

SPAN WIRE MOUNTED SIGN DETAILS

Last Revision	Sheet No.
07/01/09	1 of 1
Index No.	
17356	

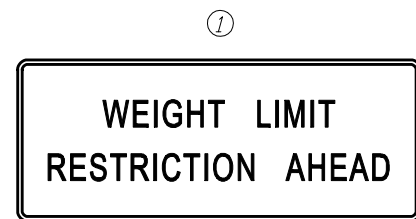
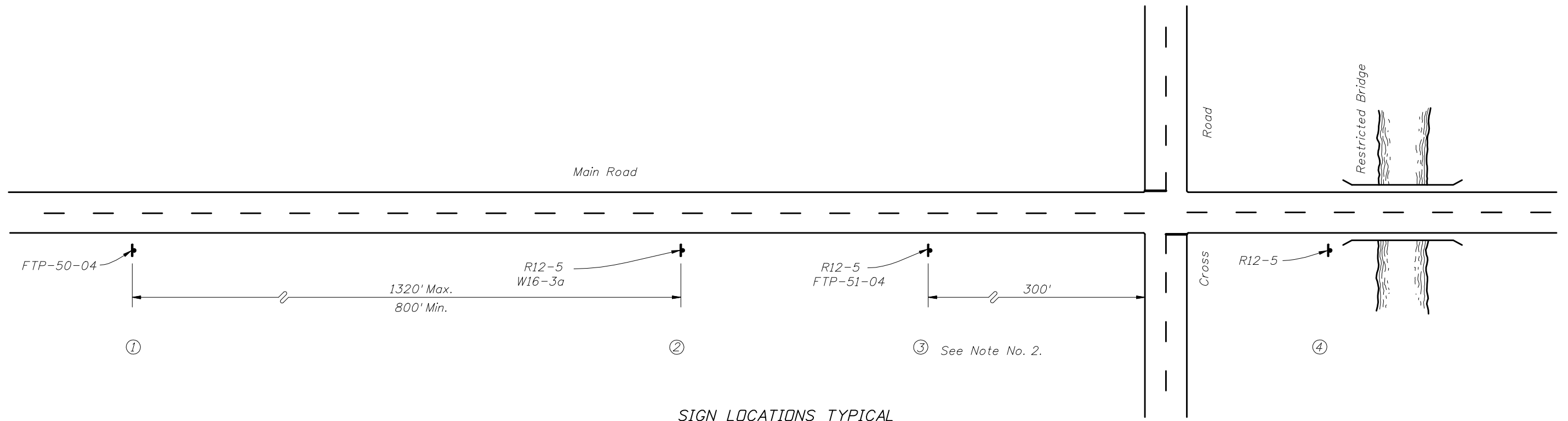

FTP-50-06



R12-5 (30" X 36")



W 16-3A



R12-5 (30" X 36")



FTP-51-06



R12-5 (30" X 36")

1. See Standard Highway Signs for sign R12-5 and W16-3 details.
2. Sign locatin No. 3 may require some field adjustment.
3. The Cross Road is the last detour to route around the restricted bridge.
4. Sign location No. 2 should be established from the Cross Road the following approximate distances; Interstate-1 Mile Non- Interstate-1/2 Mile.
5. See Index 17355 for sign details.



2010 FDOT Design Standards

BRIDGE WEIGHT RESTRICTIONS

Last Revision 07/01/04	Sheet No. 1 of 1
Index No. 17357	

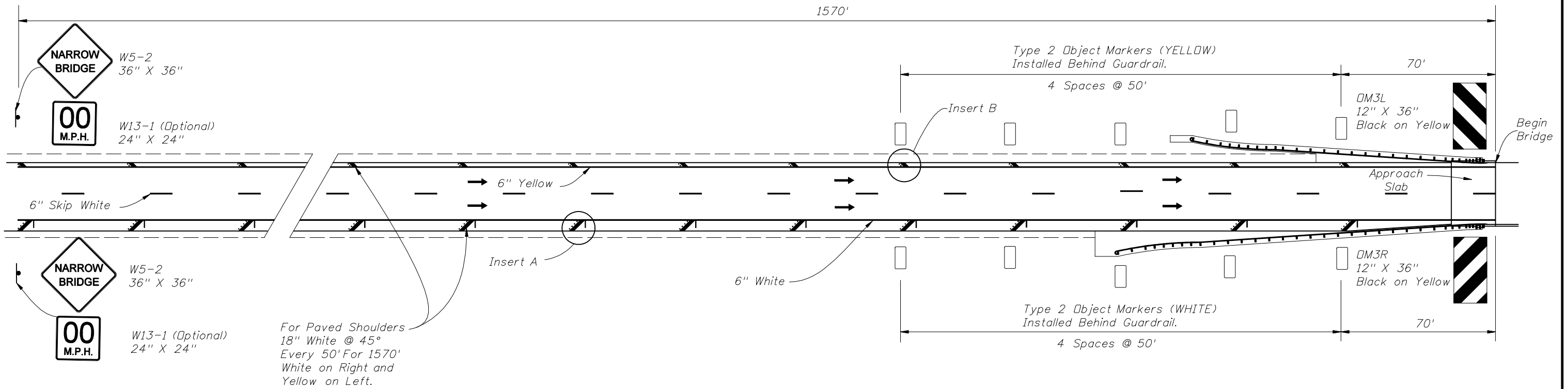

One-Way Traffic

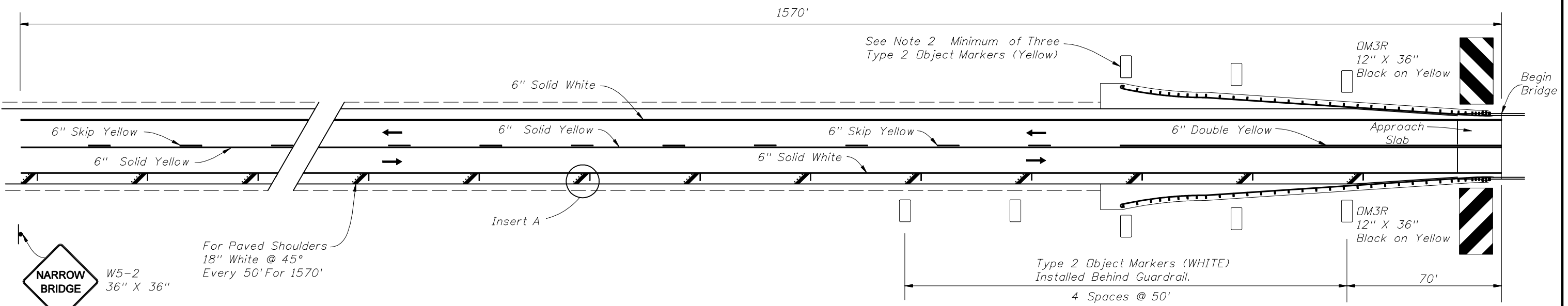

2-Way Traffic



2010 FDOT Design Standards

**RURAL NARROW
BRIDGE TREATMENT**

Last Revision	Sheet No.
07/01/09	1 of 2
Index No.	
17359	

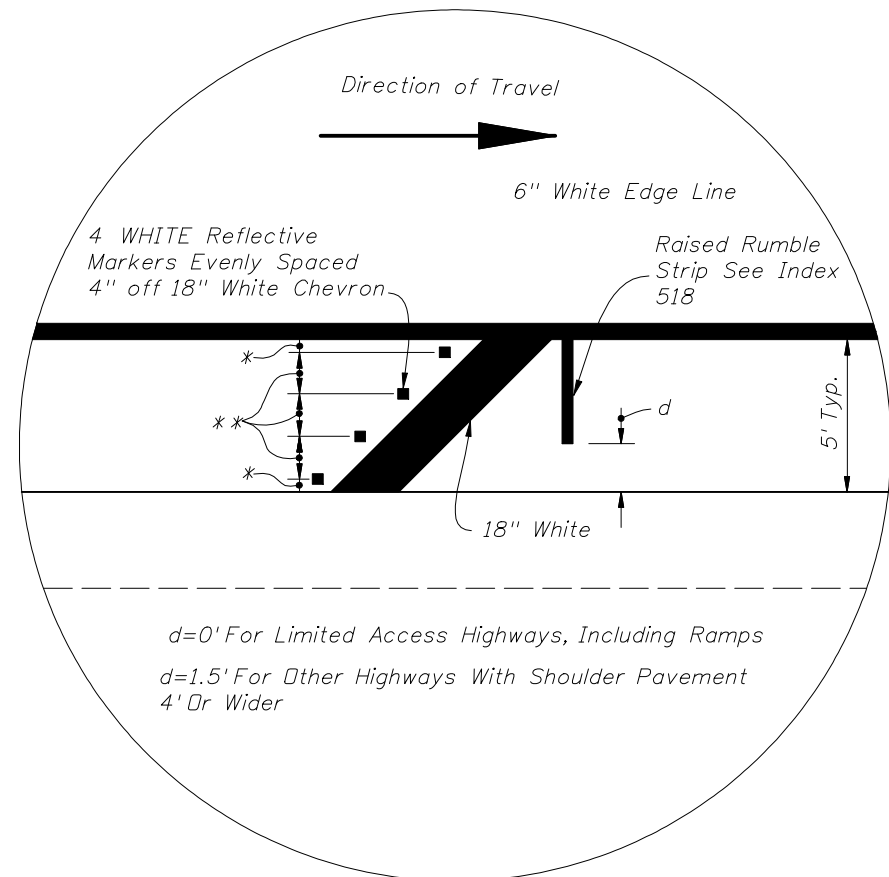

$d=0'$ For Limited Access Highways, Including Ramps
 $d=1.5'$ For Other Highways With Shoulder Pavement
 4' Or Wider

- * $\frac{1}{8}$ Length (4' and 5' shoulder)
 $\frac{1}{4}$ Length (2' shoulder)
- ** $\frac{1}{4}$ Length (4' and 5' shoulder)
 $\frac{1}{2}$ Length (2' shoulder)

INSERT A

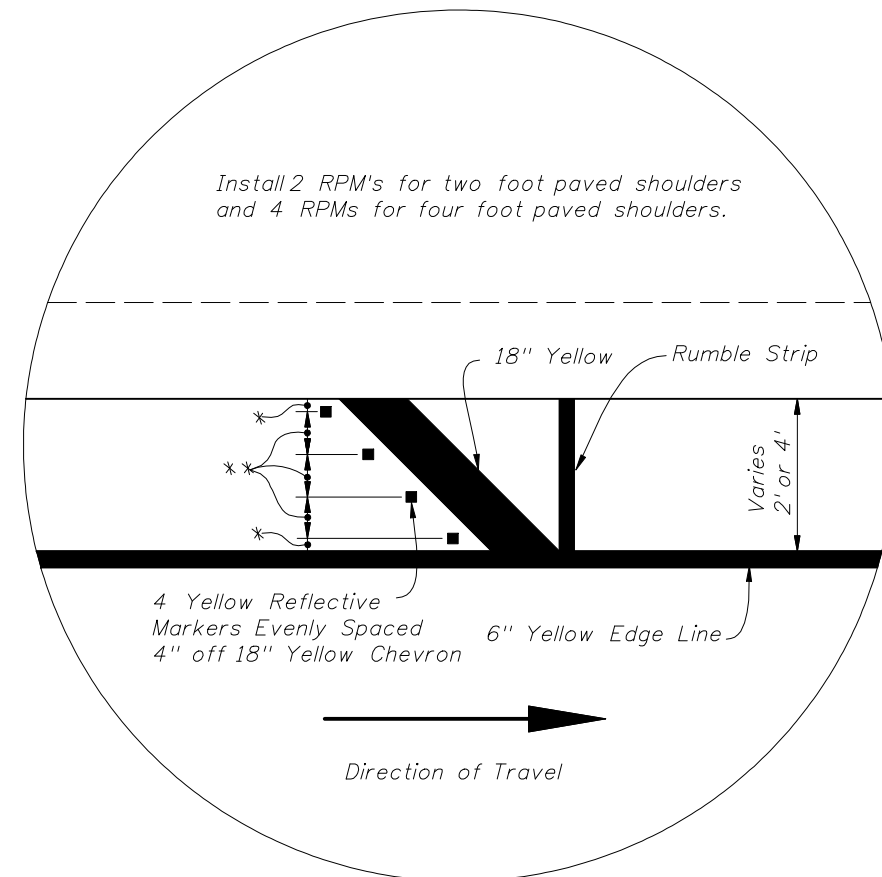

Install 2 RPM's for two foot paved shoulders
 and 4 RPMs for four foot paved shoulders.

- * $\frac{1}{8}$ Length (4' and 5' shoulder)
 $\frac{1}{4}$ Length (2' shoulder)
- ** $\frac{1}{4}$ Length (4' and 5' shoulder)
 $\frac{1}{2}$ Length (2' shoulder)

INSERT B

NOTES:

1. Bridges should be marked as narrow bridges under the following conditions:
 - (1) For approach roadways with paved shoulders when the bridge width including shoulders is less than the width of the approach roadway including paved shoulders.
 - (2) For approach roadways without paved shoulders when the bridge shoulder width is less than 2'.
2. Roadways with Two-Way Traffic:
 No passing zone should be extended 1570' in advance of narrow bridge.
3. If the bridge or the approach is on a curve, delineators shall be installed for a distance of 1570' in advance of narrow bridge on the outside portion of the roadway. Spacing shall be 100' between delineators. Delineators are to be placed not less than 2' or not more than 8' outside the outer edge of pavement.
4. Object markers and delineators on both sides of roadway shall face traffic approaching bridge
5. The DM-3R & DM-3L object markers shall be installed 4' above the roadway edge. The panels may be post mounted at the bridges.

