

HIGHMAST LIGHTING NOTES:

- 1) High Mast materials:
  - a. Pole: ASTM A1011 Grade 50, 55, 60 or 65 (Less than 1/4") or ASTM A572 Grade 50, 55, 60, or 65 (1/4" and over) or ASTM A595 Grade A (55 ksi yield) or Grade B (60 ksi yield).
  - b. Steel Plates: ASTM A709 Grade 36 or ASTM A36
  - c. Weld Metal: E70XX
  - d. Anchor Bolts: ASTM F1554 Grade 55 with ASTM A563, Grade A heavy-hex nuts and ASTM F436 Type I washers.
  - e. Handhole: ASTM A709 Grade 36 or ASTM A36 Frame with ASTM A36 cover.
  - f. Caps: ASTM A1011 Grade 50, 55, 60 or 65 or ASTM B209.
  - g. Nut Covers: ASTM B26 (319-F)
  - h. Stainless Steel Screws: AISI Type 316
- 2) Reinforcing steel: ASTM A615, Grade 60.
- 3) Concrete: Class IV (Drilled Shaft) with a minimum 4,000 psi compressive strength at 28 days for all environmental classifications.
- 4) Grout: minimum 5,000 psi compressive strength at 28-days and meeting the requirements of Section 934.
- 5) Welding: American Welding Society Structural Welding Code (Steel) ANSI/AWS D1.1 (Current edition).
- 6) Galvanization:
  - a. Nuts, Bolts, Washers and Threaded Bars/Studs: ASTM F2329.
  - b. Other items (Including Pole): ASTM A123
- 7) Hole diameters for anchor bolts: not greater than the bolt diameter plus 1/2".
- 8) Poles: Tapered with the diameter changing at a rate of 0.14 inch per foot with a minimum 16-sided pole shaft and only one longitudinal seam weld. Circumferentially welded pole shaft butt splices and laminated pole shafts are not permitted. Longitudinal seam welds within 6 inches of pole to base must be complete penetration welds. Longitudinal seam welds at telescopic field joints must be complete penetration welds for the splice length plus 6 inches.
- 9) If a grout pad is not installed, place wire cloth screen vertically between the base plate and top of foundation, wrap horizontally around the base plate with a 3" min. lap. Use standard grade, plain weave, 1/2"x1/2" mesh, galvanized steel wire-cloth with 0.063" dia. wire. Attach the screen to the base plate with stainless steel self-tapping 1/4" screws with stainless steel washers spaced at 9" centers.
- 10) One hundred percent of full-penetration groove welds and a random 25 percent of partial penetration groove welds shall be inspected. Full-penetration groove weld inspection shall be performed by nondestructive methods of radiography or ultrasonics.
- 11) Furnish each pole with a 2"x4" (max.) aluminum identification tag. Submit details for approval. Secure to pole with 0.124" stainless steel rivets or screws. Locate identification tag on the inside of pole and visible from handhole. Include the following information: Financial Project ID, Pole Mounting Height, Manufacturer's Name, Certification Number and QPL Number.
- 12) Manufacturers seeking approval of a Highmast Lighting structural assembly (exclude lowering system) for inclusion on the Qualified Products List must submit a QPL Production Evaluation Application along with drawings showing the product meets all specified requirements of this Index.

DESIGN CRITERIA:

- 1) Designed in accordance with the FDOT Structures Manual.
- 2) Poles are designed to support the following:
  - a. (1) cylindrical head assembly with a maximum effective projected area of 6 Sq. ft. (Cd=1) and 340 lbs (Max).
  - b. (8) cylindrical luminaires with a maximum effective projected area of 3.0 Sq. ft (Cd=0.5) and 77 lbs. each.
- 3) Foundation design based upon the following soil criteria:
  - Classification = Cohesionless (Fine Sand)
  - Friction Angle = 30 Degrees (30°)
  - Unit Weight = 50 lbs./cu. Ft. (assumed saturated)

Only in cases where the Designer considers the soil types at the specific site location to be of lesser strength properties should an analysis be required. Auger borings, SPT borings or CPT soundings may be utilized as needed to verify the assumed soil properties, and at relatively uniform sites, a single boring or sounding may cover several foundations. Furthermore, borings in the area that were performed for other purposes may be used to confirm the assumed soil properties.
- 4) Foundation applies only to slopes of 1:4 or flatter. Provide a minimum 24" shaft projection on the high side.
- 5) Poles are designed for 6 mil galvanization thickness.

STANDARD POLE DESIGN NOTES

REVISIONS							2008 Interim Design Standard		Interim Date	Sheet No.
DATE	BY	DESCRIPTION	DATE	BY	DESCRIPTION		HIGHMAST LIGHTING		07/01/08	3 of 7
01/01/08	DYW	Changed Note 9, Renumbered Notes 10 thru 12. Added Notes 10 & 11.								
07/01/08	DYW	Changed notes 11 & 12.								
									Index No.	17502

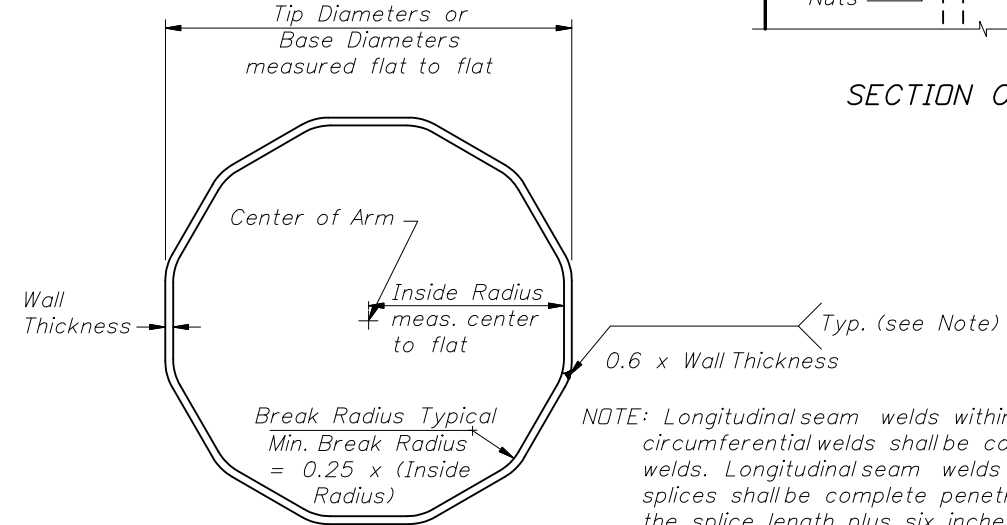
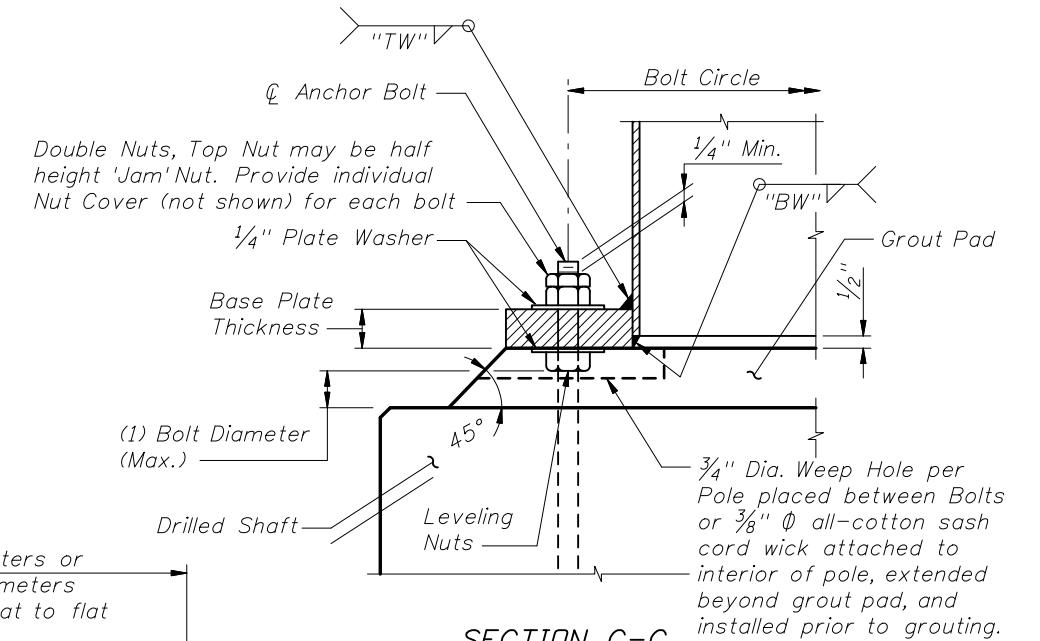
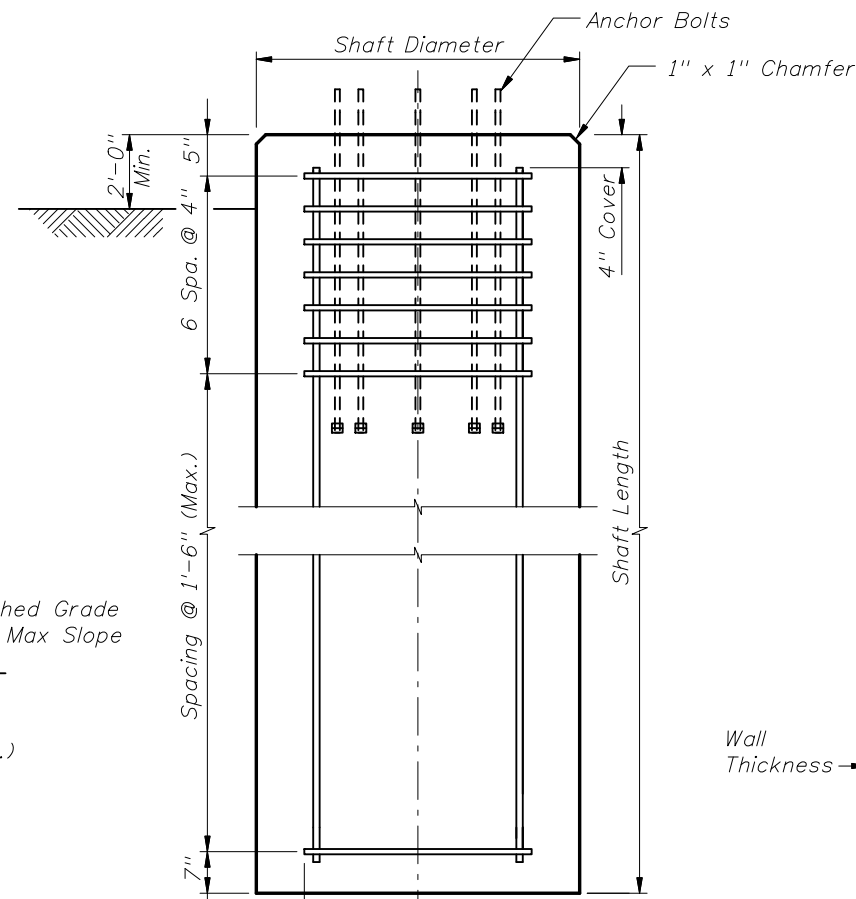
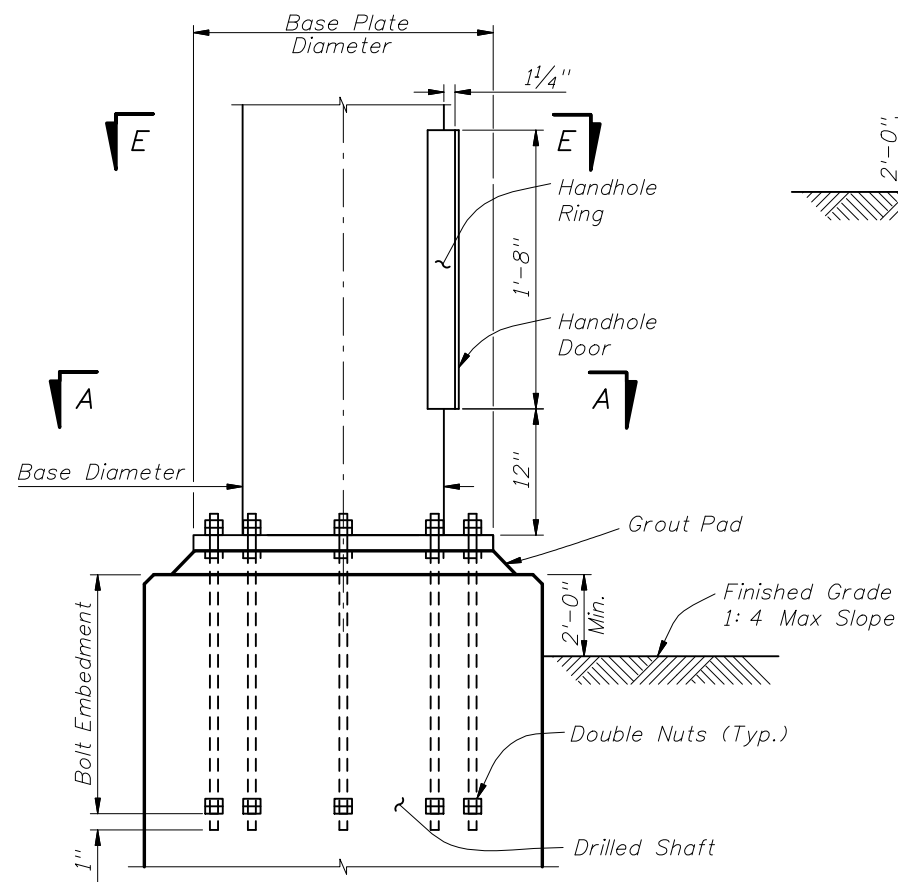
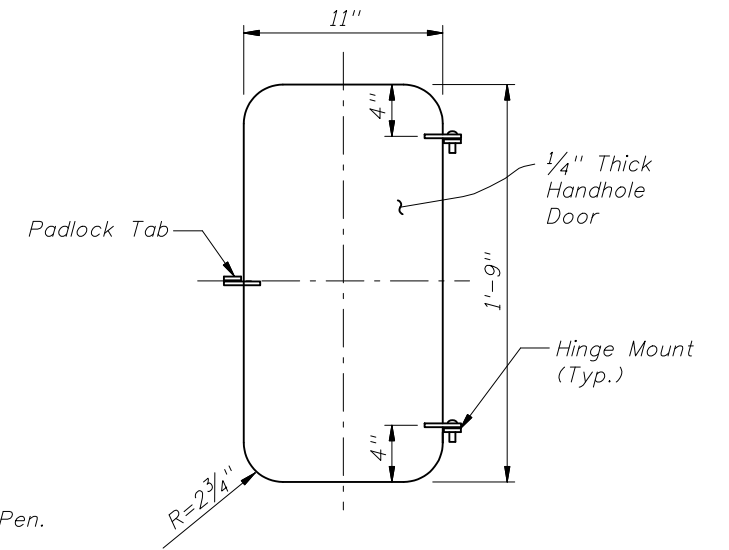
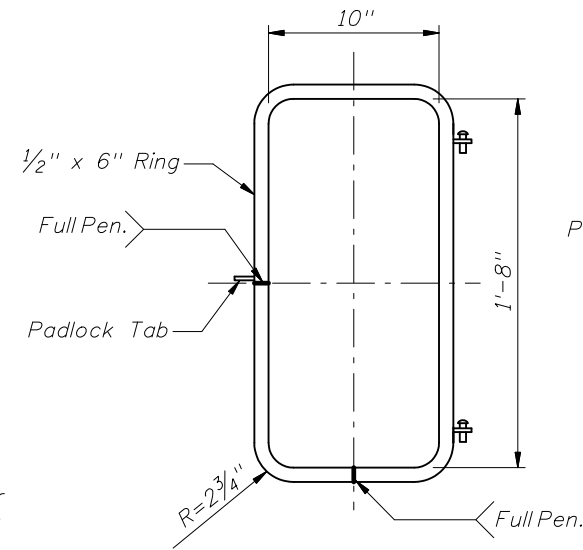
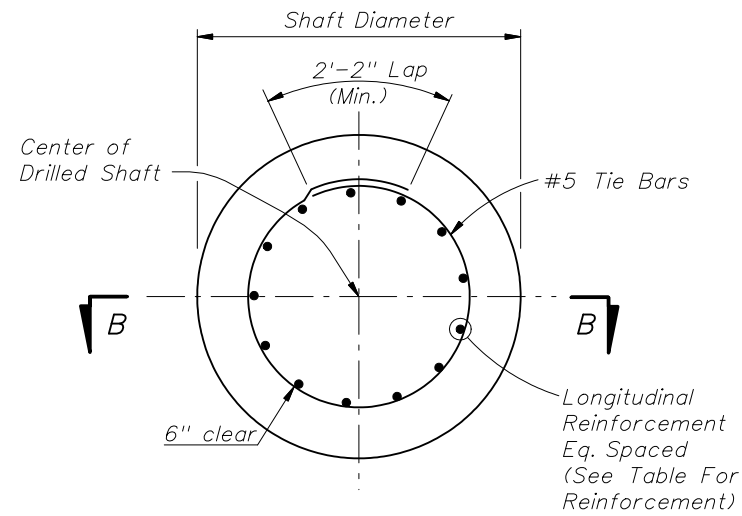
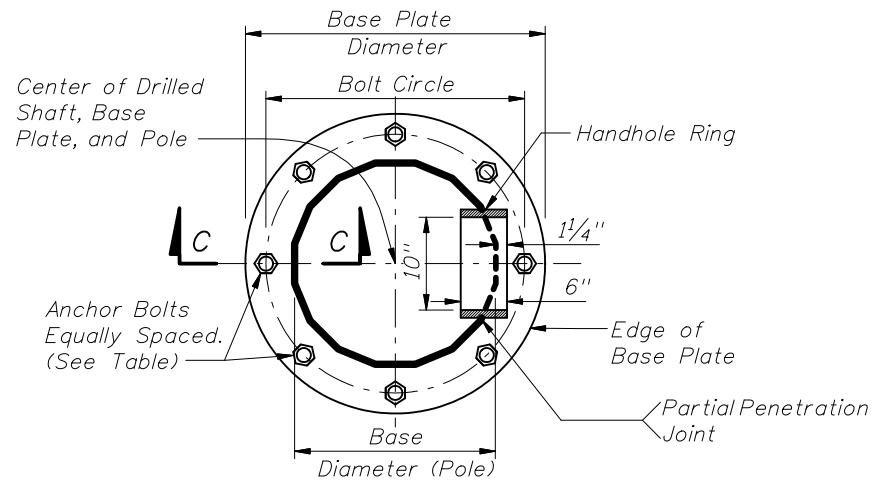

NOTE: Longitudinal seam welds within six inches of circumferential welds shall be complete penetration welds. Longitudinal seam welds at telescopic field splices shall be complete penetration welds for the splice length plus six inches. For tubes greater than 70" in circumference, two longitudinal seam welds are allowed.

POLE FOUNDATION

REVISIONS

DATE	BY	DESCRIPTION	DATE	BY	DESCRIPTION
01/01/08	DYW	Changed Weld symbol in SECTION A-A, Added Padlock Tab to HANDHOLE RING.			
07/01/08	DYW	Added SECTION E-E, washer for Base Plate.			



2008 Interim Design Standard

HIGHMAST LIGHTING

Interim Date

07/01/08

Sheet No.

5 of 7

Index No.

17502