

**GENERAL NOTES**

- This fence to be used generally in urban areas.
- For supplemental information refer to Section 550 of FDOT Standard Specifications.
- Chain link fabric, posts, rails, truss rods, tension wires, tie wires, stretcher bars, gates and all miscellaneous fittings and hardware shall meet the requirements of AASHTO M181 unless otherwise specified by this index. Stipulated AASHTO and ASTM signify current reference.
- Fence Component Options:
  - Line post options:
    - Galvanized steel pipe, Schedule 40- 1 1/2" nominal dia. zinc galvanized at the rate of 1.8 oz./ft.<sup>2</sup>; ASTM A53 Table X 2, ASTM F1083, and AASHTO Mill.
    - Aluminum coated steel pipe; ASTM A53, X 2 Tables Schedule 40; 1 1/2" nominal dia., 1.90" OD; coated at the rate 0.40 oz./ft.; AASHTO Mill.
    - Aluminum alloy pipe- 2" nominal dia.: ASTM B241 or B221, Alloy 6063, T6.
    - Steel H-Beam- 1 1/2" x 1 1/8": Zinc Galv. 1.8 oz./ft.; AASHTO Mill and Detail.
    - Aluminum alloy H-Beam- 1 1/2" x 1 1/8": Detail.
    - Steel C- 1 1/8" x 1 1/8": Galv.: 1.8 oz./ft. zinc; AASHTO Mill; or, 0.9 oz./ft.<sup>2</sup> zinc- 5% aluminum-mischmetal; ASTM F1043 and Detail.
    - Resistance welded steel pipe; 50,000 psi min. yield strength ASTM A569/A569M, A653/A653M or undepleted stock of discontinued A446/A446M base materials; ASTM F669 Group IV (Alternative Design); fence industry 2" OD, 1 1/2" NPS, 1.900" dec. equiv., 0.120" min. wall thick. and min. wt. 2.28 lb./ft.; with ASTM F1043 metric equivalent internal coating Types A, B, C or D and external coating Types A, B, or C; the chromate conversion coating of external Type B shall have a thickness of 15 µg/in.<sup>2</sup> min. and the polymer film topcoat shall have a thickness of 0.0003" min.; internal and external coatings are not restricted to the combinations of Table 2, ASTM F1043.
  - Corner, end, and pull post options:
    - Galvanized steel pipe, Schedule 40- 2" nominal dia. zinc galvanized at the rate of 1.8 oz./ft.<sup>2</sup>; ASTM A53 Table X 2, ASTM F1083, and AASHTO Mill.
    - Aluminum coated steel pipe; ASTM A53 steel, X 2 Tables Schedule 40; 2" nominal dia., 2.375" OD; coated at the rate 0.40 oz./ft.; AASHTO Mill.
    - Aluminum alloy pipe- 2 1/2" nominal dia.: ASTM B241 or B221, Alloy 6063, T6.
    - Resistance welded steel pipe; 50,000 psi min. yield strength ASTM A569/A569M, A653/A653M or undepleted stock of discontinued A446/A446M base materials; ASTM F669 Group IV (Alternative Design); fence industry 2 1/2" OD, 2" NPS, 2.375" dec. equiv., 0.130" min. wall thick. and min. wt. 3.17 lb./ft.; with ASTM F1043 metric equivalent internal coating Types A, B, C or D and external coating Types A, B, or C; the chromate conversion coating of external Type B shall have a thickness of 15 µg/in.<sup>2</sup> min. and the polymer film topcoat shall have a thickness of 0.0003" min.; internal and external coatings are not restricted to the combinations of Table 2, ASTM F1043.
  - Rail options:
    - Galvanized steel pipe, Schedule 40- 1 1/4" nominal dia. zinc galvanized at the rate of 1.8 oz./ft.<sup>2</sup>; ASTM A53 Table X 2, ASTM F1083, and AASHTO Mill.
    - Aluminum coated steel pipe; ASTM A53 steel, X 2 Tables Schedule 40; 1 1/4" nominal dia., 1.660" OD; coated at the rate 0.40 oz./ft.; AASHTO Mill.
    - Aluminum alloy pipe- 1 1/4" nominal dia.: ASTM B241 or B221, Alloy 6063, T6.
    - Resistance welded steel pipe; 50,000 psi min. yield strength ASTM A569/A569M, A653/A653M or undepleted stock of discontinued A446/A446M base materials; ASTM F669 Group IV (Alternative Design); fence industry 1 1/4" OD, 1 1/4" NPS, 1.660" dec. equiv., 0.111" min. wall thick. and min. wt. 1.836 lb./ft.; with ASTM F1043 metric equivalent internal coating Types A, B, C or D and external coating Types A, B, or C; the chromate conversion coating of external Type B shall have a thickness of 15 µg/in.<sup>2</sup> min. and the polymer film topcoat shall have a thickness of 0.0003" min.; internal and external coatings are not restricted to the combinations of Table 2, ASTM F1043.

- Chain link fabric options (2" mesh with twisted and barbed selvage top and bottom for all options except as described in Note No. 10):
  - AASHTO M181 Type I - Zinc Coated Steel, No. 9 gage (coated wire diameter), coated at the rate of 1.8 oz./ft.<sup>2</sup> (M181 Class D 2.0 oz./ft.<sup>2</sup> modified to 1.8 oz./ft.<sup>2</sup>).
  - AASHTO M181 Type II - Aluminum Coated Steel, No. 9 gage (coated wire diameter), coated at the rate of 0.40 oz./ft.<sup>2</sup>.
  - AASHTO M181 Type III - Polyvinyl Chloride (PVC) Coated Steel, No. 9 gage (coated core wire diameter), core wire-zinc coated steel. PVC coating: M181 Class A (either extruded or extruded and bonded) or Class B (bonded). See table right. Unless the plans call for M181 standard colors medium green, dark green or black the coating color shall be soft gray matching that of No. 36622 of Federal Standard 595a.
- Tension wire options:
  - Steel wire No. 7 gage zinc galvanized at the rate of 1.2 oz./ft.<sup>2</sup>; AASHTO M181.
  - Aluminum alloy wire with a diameter of 0.1875" or larger conforming to the requirements of ASTM B211, Alloy 5056 Temper H38, or, Alclad Alloy 5056 Temper H192.
  - Aluminum coated steel wire No. 7 gage coated at the rate of 0.40 oz./ft.<sup>2</sup>; AASHTO M181.
- Tie wire and hog ring options:
  - Steel wire No. 9 gage zinc galvanized at the rate of 1.2 oz./ft.<sup>2</sup>.
  - Aluminum alloy wire with a diameter of 0.1443" or larger conforming to the requirements of ASTM B211, Alloy 5056 Temper H38, or, Alclad Alloy 5056 Temper H192.
  - Aluminum coated steel wire No. 7 gage coated at the rate of 0.40 oz./ft.<sup>2</sup>.
- Unless a specific material is called for in the plans the Contractor may elect to use either a single type of material or a combination of material types from the component options listed above. Combinations of optional materials are restricted as follows: (a) Only one fabric optional material will be permitted between corner and/or end post assemblies. (b) Only one line post optional material will be permitted between corner and/or end post assemblies. (c) Pull post assemblies shall be optional materials identical to either the line post optional material or the corner and end post assembly optional material; but, pull post assemblies shall be the same optional material between any set of corner and/or end post assemblies.
- Concrete for bases shall be Class I concrete as specified in Section 347 of the Standard Specifications or a packaged, dry material meeting the requirements of a concrete under ASTM C-387. Materials for Class I concrete may be proportioned by volume and/or by weight.
- Line posts are to be set in concrete as detailed above or by the following methods:
  - In accordance with special details and/or as specifically described in the contract plans and specifications.
  - In accordance with ASTM F567 Subsections 5.4 through 5.10 as approved by the Engineer.
  - Posts mounted on concrete structure or solid rock shall be mounted in accordance with the base plate detail "Fence Mounting On Concrete Endwalls And Retaining Wall", Sheet 2; or, by embedment in accordance with ASTM F567 Subsection 5.5.

- Pull posts shall be used at breaks in vertical grades of 15° or more, or at approximately 350' centers except that this maximum interval may be reduced by the Engineer on curves where the curve is greater than 3°.
- Corner posts are to be installed at all horizontal breaks in fence at 15° or more and as required at vertical breaks over 15° as determined by the Engineer.
- When fence has an installed top of fabric height less than 6', knuckled top and bottom selvages shall be used unless the plans specifically identify locations for twisted selvage fabrics.
- Unless sliding gates or special gates are called for in the plans, all gates shall be chain link swing gates meeting the material requirements described above as approved by the Engineer. Payment shall include the gates, single or double, all necessary hardware for installation and any additional length and/or size for posts at the opening. Gates shall be paid for under the contract unit price for Fence Gates, EA.
- For construction purposes corner post assemblies shall consist of one corner post, two braces, two truss rods, and all necessary fittings and hardware as detailed above.
- End post assemblies shall consist of one end post, one brace, one truss rod and all necessary fittings and hardware as detailed above.
- All posts, tension wires, chain link fabric, tie wires, Class I concrete, and all miscellaneous fittings and hardware to be included in the cost for Fencing, LF.

TYPE III VINYL COATED FABRIC								
AASHTO M181 Table 4 Redefined As Follows								
Specified Diameter Of Metallic Coated Core Wire	Minimum Weight Of Zinc Coating	PVC Thickness Range						
		M181 Class A (Extruded Or Extruded And Bonded Coating)		M181 Class B (Bonded Coating)				
in.	mm	gage	oz./ft. <sup>2</sup>	g/m <sup>2</sup>	in.	mm	in.	mm
0.148	3.77	9	0.30	92	0.015 to 0.025	0.38 to 0.64	0.006 to 0.010	0.15 to 0.25

**DESIGN NOTE**

This index details fencing that is constructed with chain link fabric 6' (nominal) in height and with specific ground clearance. For fencing of different height or installation details, the fence shall be fully detailed in the Contract plans.

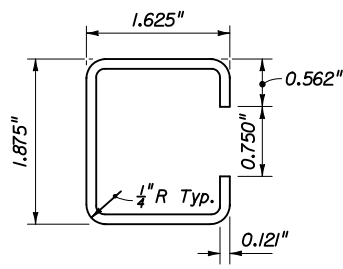

Galv. Wt. Per. Ft. = 2.34# ±5%  
Yield PSI (Min.) 45,000

STANDARD WALL

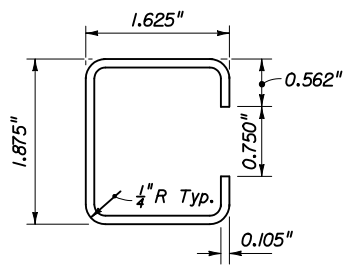

Galv. Wt. Per. Ft. = 1.85# ±5%  
Yield PSI (Min.) 45,000

THINWALL

**OPTIONAL "C" LINE POST**

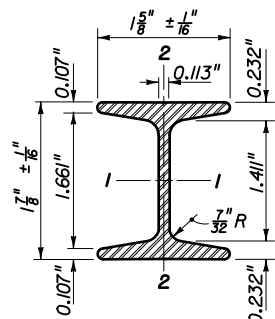

	STEEL		ALUMINUM	
Area (Sq. In.)	724		724	
Weight (Lb./Ft.)	2.72 ±5% (Galv.)		0.91 ±5%	
Surface Area (SF/Ft.)	0.776		0.776	
Tensile Strength (psi Min.)	80,000		30,000	
Yielding Point (psi Min.)	48,000		25,000	
	Axes		Axes	
	1-1	2-2	1-1	2-2
Moment of Inertia	0.428	0.101	0.428	0.101
Section Modulus	0.456	0.124	0.456	0.124
Rad. Of Gyration	0.779	0.373	0.779	0.373

**OPTIONAL 1 7/8" x 1 5/8" H-BEAM LINE POST**

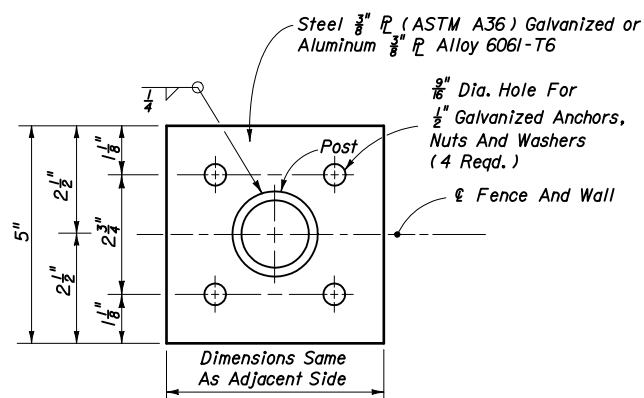

TOP VIEW  
FOUR ANCHOR OPTION

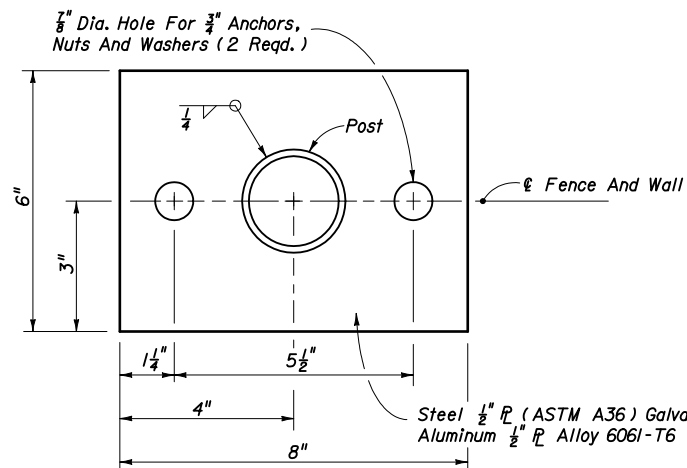

TOP VIEW  
TWO ANCHOR OPTION

**FENCE MOUNTING ON CONCRETE ENDWALL AND RETAINING WALLS**

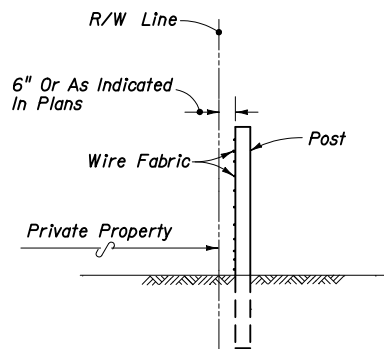

**FENCE POSITION AT LOCATIONS WITHOUT FRONTAGE ROADS**  
(REFER TO DETAIL PLANS FOR FENCE POSITION AT LOCATIONS WITH FRONTAGE ROADS)

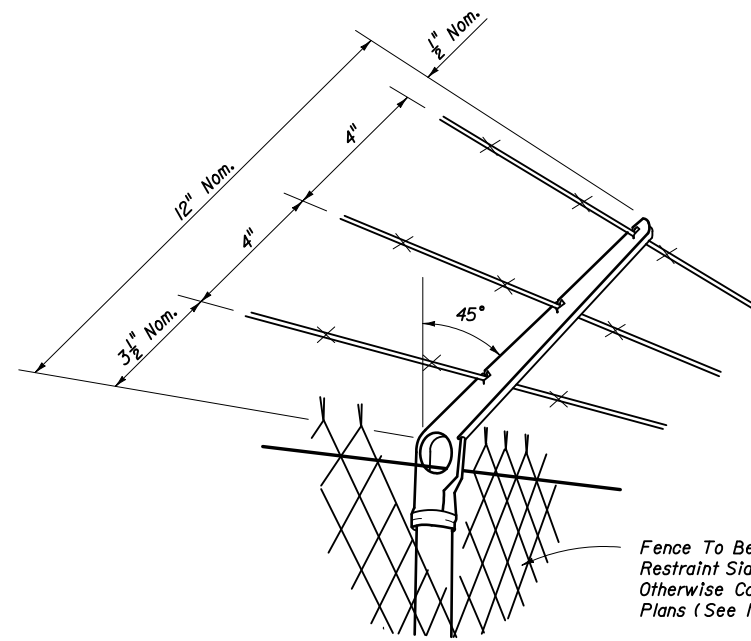

**NOTES**  
Attachments to be used only when called for in the plans.  
Attachments to extend in direction of restraint. Unless otherwise called for in plans, direction of restraint will be as follows:  
(a.) Outward on limited access right of way line.  
(b.) Outward on controlled access right of way line.  
(c.) Outward from utilities and hazardous facilities located within highway right of way.  
(d.) Outward from lateral ditches, outfalls, retention basins, canals, borrow areas and similar support facilities.  
(e.) Inward on pedestrian ways.

The cap-arm shall be designed to provide a drive fit over the top of posts and to exclude moisture in posts with tubular sections.

**BARB WIRE ATTACHMENT**

- BASE PLATE AND ANCHOR NOTES:**
1. Base plate identical for line, pull, end and corner posts and shall be considered an integral part of the respective posts for basis of payment.
  2. Post to be plumbed by grout shim under base plate.
  3. Anchors (Galvanized Steel):
    - 12" Cast In Place, 10 1/2" Embedment: Headed Bolts, U-Bolts or Cluster Plates.
    - 8" Adhesive Anchors, 6" Min. Embedment.\*
 \*Adhesive anchors shall be headless anchor bolts set in drilled holes with an Adhesive Material System in accordance with Specification Sections 416 and 937; drilled holes shall be 1/8" larger in diameter than the anchor bolt. Expansion Bolts Not Permitted.

