

TYPE II

D_1 = 5' Std. (Single Panel For Depths 5' or Less).
 D_2 = 5' Std. (Additional Panel For Depths > 5').
 Curtain To Reach Bottom Up To Depths Of 10 Feet.
 Two (2) Panels To Be Used For Depths Greater Than 10 Feet Unless Special Depth Curtains Specifically Call For In The Plans Or As Determined By The Engineer.

TYPE I

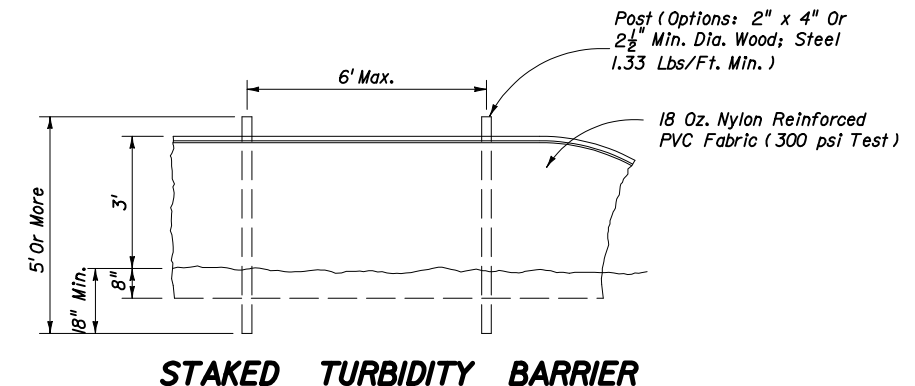
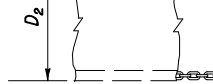

STAKED TURBIDITY BARRIER

NOTICE: COMPONENTS OF TYPES I AND II MAY BE SIMILAR OR IDENTICAL TO PROPRIETARY DESIGNS. ANY INFRINGEMENT ON THE PROPRIETARY RIGHTS OF THE DESIGNER SHALL BE THE SOLE RESPONSIBILITY OF THE USER. SUBSTITUTIONS FOR TYPES I AND II SHALL BE AS APPROVED BY THE ENGINEER.

FLOATING TURBIDITY BARRIERS

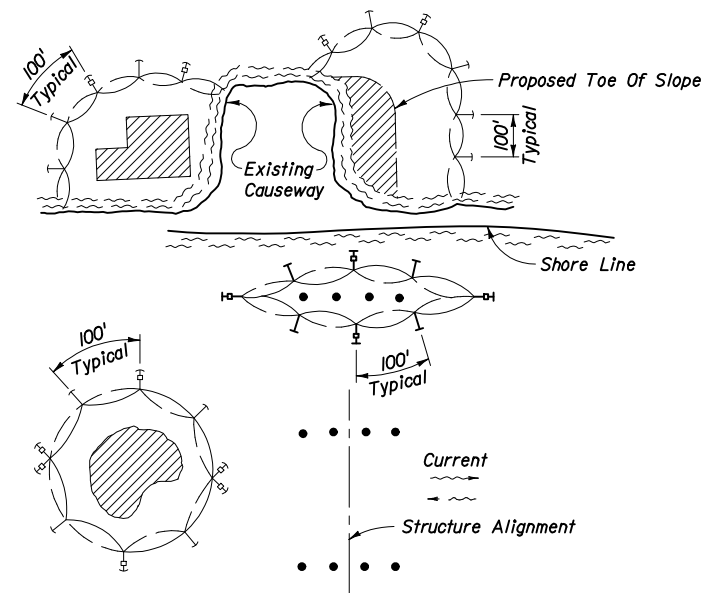

LEGEND

- Pile Locations
- ▨ Dredge Or Fill Area
- ⊕ Mooring Buoy w/Anchor
- ⊙ Anchor
- ⤴ Barrier Movement Due To Current Action

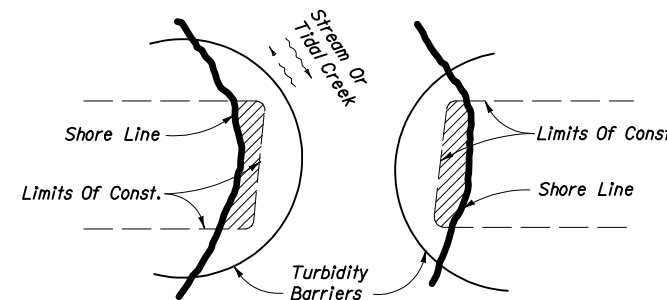

Note:
 Turbidity barriers for flowing streams and tidal creeks may be either floating, or staked types or any combinations of types that will suit site conditions and meet erosion control and water quality requirements. The barrier type(s) will be at the Contractor's option unless otherwise specified in the plans, however payment will be under the pay item(s) established in the plans for Floating Turbidity Barrier and/or Staked Turbidity Barrier. Posts in staked turbidity barriers to be installed in vertical position unless otherwise directed by the Engineer.

NOTES:

1. Turbidity barriers are to be used in all permanent bodies of water regardless of water depth.
2. Number and spacing of anchors dependent on current velocities.
3. Deployment of barrier around pile locations may vary to accommodate construction operations.
4. Navigation may require segmenting barrier during construction operations.
5. For additional information see Section 104 of the Standard Specifications.

GENERAL NOTES

1. Floating turbidity barriers are to be paid for under the contract unit price for Floating Turbidity Barrier, LF.
2. Staked turbidity barriers are to be paid for under the contract unit price for Staked Turbidity Barrier, LF.

TURBIDITY BARRIER APPLICATIONS



2006 FDOT Design Standards

TURBIDITY BARRIERS

Last Revision 00 Sheet No. 1 of 1

Index No. 103