



This memo has expired

Florida Department of Transportation

JEB BUSH
GOVERNOR

605 Suwannee Street
Tallahassee, FL 32399-0450

DENVER J. STUTLER, JR.
SECRETARY

November 13, 2006

To: District Directors of Operations, District Directors of Production, District Design Engineers, District Construction Engineers, District Geotechnical Engineers, District Structures Design Engineers

FROM: William Nickas, P. E., State Structures Design Engineer
for Brian Blanchard, P.E., Director, Office of Construction

COPIES: Bob Greer, Jeffrey Ger (FHWA), Tim Lattner, Duane Brautigam, David O'Hagan, Larry Jones, Robert Robertson, Larry Sessions, Andre Pavlov, Marcus Ansley, Lex Collins, Steve Plotkin, Elwin Broome.

SUBJECT: Temporary Design Bulletin C06-10
DCE Memorandum No. 28-06
Mandatory Utilization of Embedded Data Collectors (EDC) in Prestressed Concrete Test Piles (2 pages)

REQUIREMENT

On all projects with bridges containing 18", 24" or 30" prestressed concrete test piles, modify the Summary of Pay Items to include Pay Item No. 455-146 (Embedded Data Collector – each). The Embedded Data Collector (EDC) quantity will be one per prestressed concrete test pile. Include Special Provision 455-5.12 in the Specifications Package for these projects. Review the plans to assure there are not any conflicts between plan notes and the new special provision.

COMMENTARY

EDC can not be used with steel pipe piles or H-piles. In voided prestressed concrete piles, the length of the solid sections at the tip and toe of the piles shall be at least 4 pile diameters long. Design Standards Index 20630 for 30" Prestressed Concrete Piles has been revised to extend the solid section at the head and toe and will be released as an interim standard along with the interim standard for the EDC. The EDC will be cast into these solid sections, along the axis of the pile, ≥ 2 pile diameters from the end and ≥ 2 pile diameters from any cross-section change such as a pile void or vent.

BACKGROUND

Embedded Data Collector (EDC) technology is the result of a research study by the University of Florida sponsored by FDOT. FDOT has made a commitment to advance EDC technology in prestressed piling by establishing a statistically significant database of approximately 200 piles

monitored concurrently with both EDC and conventional dynamic monitoring methods and then compiling a statistical comparison of the test results. In order to establish this database in a reasonable period of time, FDOT is requiring EDC data collection concurrent with conventional test pile monitoring equipment on all bridge projects beginning January 2007 lettings.

In order to minimize the impact to each Districts' production schedule, a special provision has been drafted and forwarded to FHWA for review, and Interim Design Standards Index 20602 will provide EDC installation details. The special provision will need to be incorporated into the projects as a mandatory specifications change in the January 2007 Workbook.

Interim Design Standards Index 20602 will be posted on the Design Standards Website which will provide construction details for the EDC. The Design Standards Modifications (DSM) dated January 1, 2007 has been edited to include a reference to this Interim Index. Since no projects using this version of the DSM have been let as of this time, the date of the DSM remains unchanged. It therefore is not necessary to revise the DSM note on the Key Sheet.

IMPLEMENTATION

This policy is effective for all projects with 18", 24" or 30" prestressed concrete test piles let after January 1, 2007.

CONTACT

Larry Jones
Assistant State Structures Design Engineer
& State Geotechnical Engineer
Florida Department of Transportation
605 Suwannee Street, MS 33
Tallahassee, FL 32399-0450
phone (850)-414-4305, fax (850)-414-4955
e-mail: Larry.Jones@DOT.STATE.FL.US

WNN/BB/LEJ/RR



Florida Department of Transportation

JEB BUSH
GOVERNOR

605 Suwannee Street
Tallahassee, FL 32399-0450

DENVER J. STUTLER, JR.
SECRETARY

November 1, 2006

MEMORANDUM

TO: DAVID SADLER, CONSTRUCTION ENGINEER
JIM JOHNSON, CONSTRUCTION SYSTEMS ENGINEER

FROM: Brian Blanchard, Director, Office of Construction *Brian Blanchard*

COPIES: Wynette Williams, Administrative Assistant

SUBJECT: DELEGATION OF SIGNATURE AUTHORITY

This is to delegate signature authority for documents (excluding personnel actions) to you for when I am out of the office or on travel status from this date through July 1, 2007.

Ms. Williams is also delegated signature authority for administrative type actions.

Please insure that my office receives a copy of all correspondence signed by you for these dates.

BB/ww

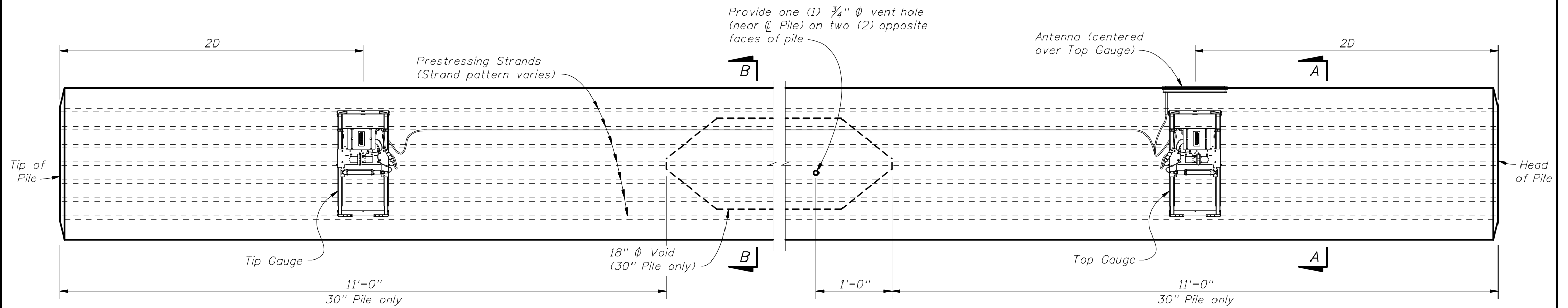

ELEVATION

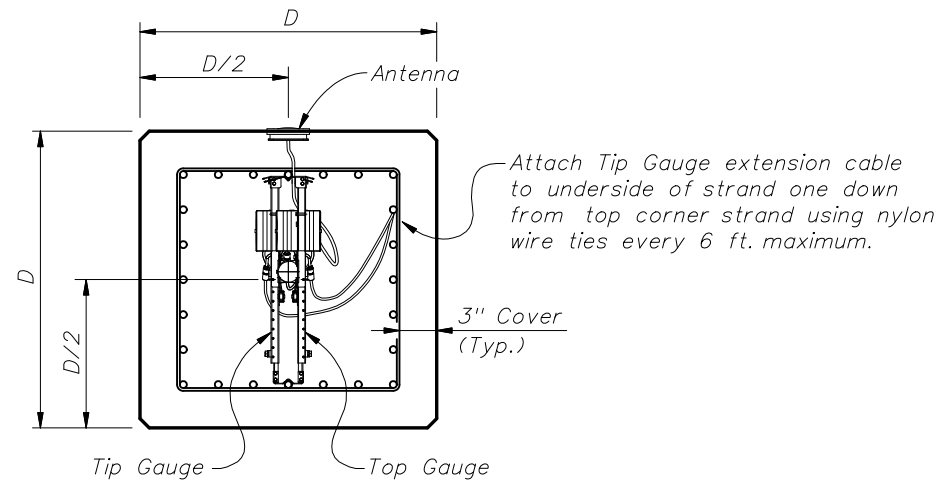

SECTION A-A

(Strand Pattern with odd number of strands per face)

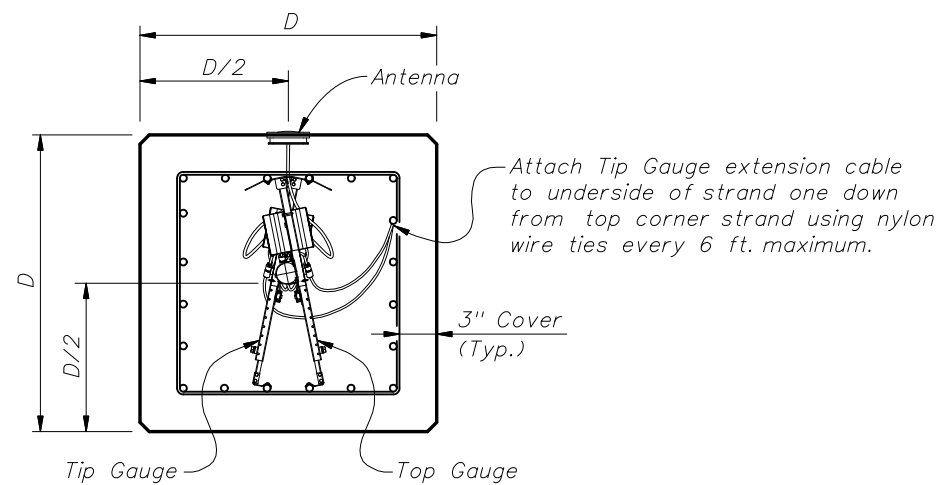

SECTION A-A

(Strand Pattern with even number of strands per face)

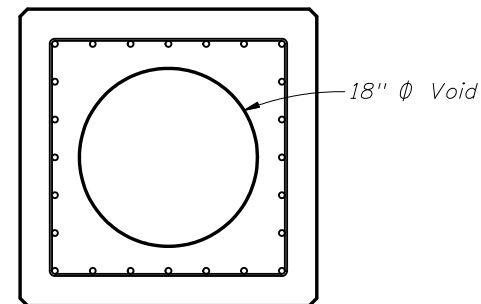

SECTION B-B
(30" Pile only)

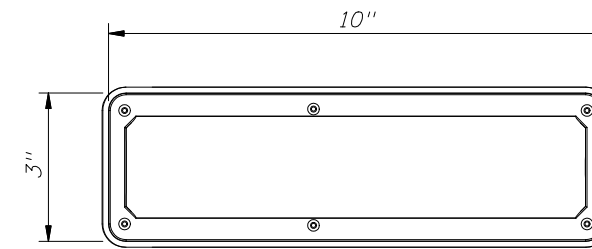

ANTENNA TOP VIEW

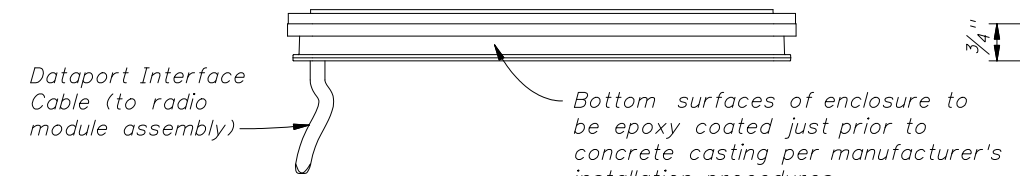

ANTENNA SIDE VIEW

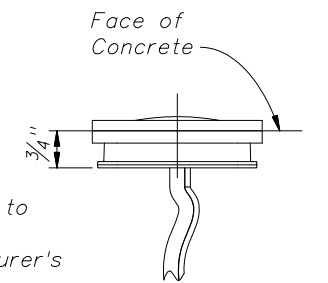

ANTENNA END VIEW

Work this sheet with
Index No. 20618 for 18" square piles,
Index No. 20624 for 24" square piles,
Index No. 20630 for 30" square piles.

REVISIONS

DATE	BY	DESCRIPTION	DATE	BY	DESCRIPTION
11/07/06	LEJ	New Design Standard.			

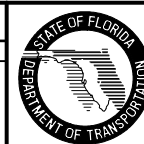

2006 Interim Design Standard

EDC INSTRUMENTATION FOR
SQUARE PRESTRESSED CONCRETE PILES

Interim Date
11/07/06

Sheet No.
1 of 1

Index No.
20602

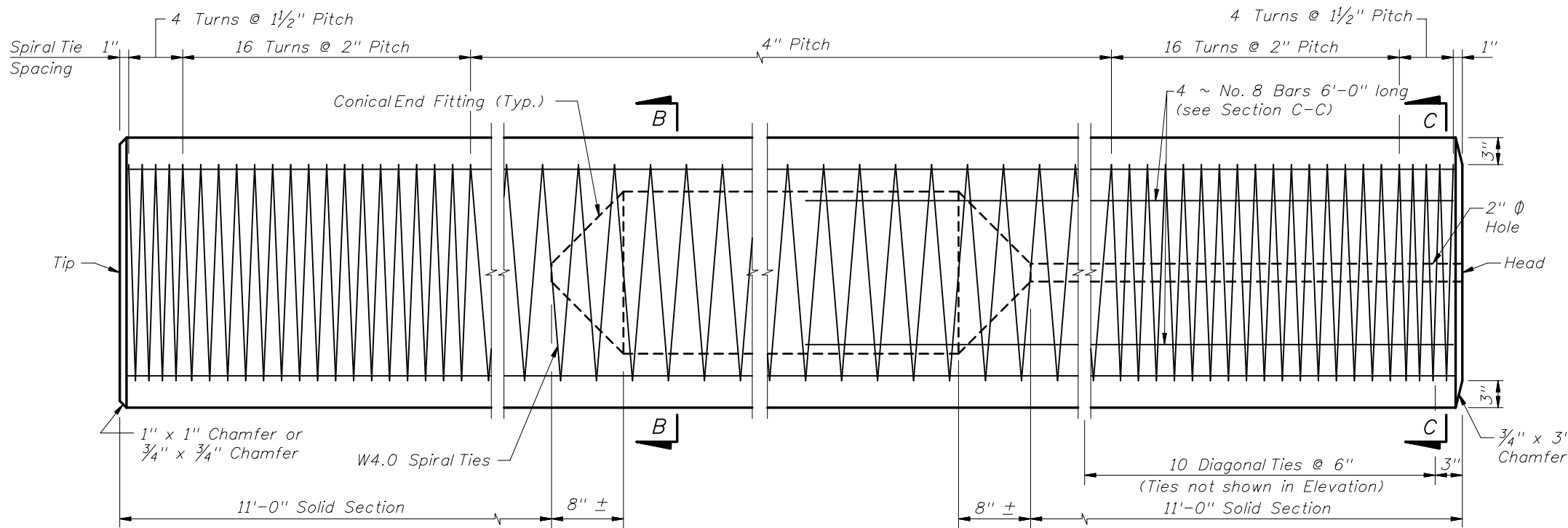

NOTE:
Work this Index with Index No. 20600 - Notes and Details for Square Prestressed Concrete Piles and Index No. 20601 - Square Prestressed Concrete Pile Splices.

ELEVATION

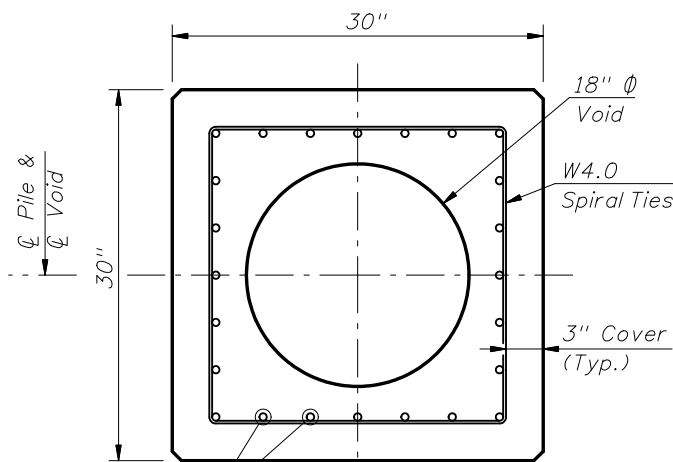

SECTION B-B

(See Pile Splice Reinforcement Details)

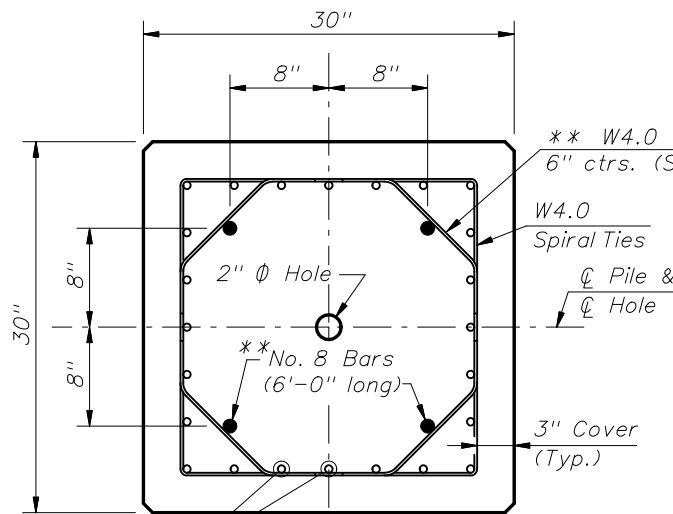

SECTION C-C

(See Pile Splice Reinforcement Details)

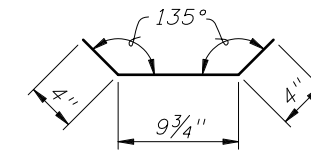

W4.0 DIAGONAL TIE DETAIL

** Omit 4 ~ No. 8 Bars and Diagonal Ties in pre-planned mechanical splice.

ALTERNATE STRAND PATTERNS

- 20 ~ 9/16" Ø, Grade 270 (Spec) LRS, at 39.7 kips
- 20 ~ 9/16" Ø, Grade 270 LRS, at 39.0 kips
- 20 ~ 0.6" Ø, Grade 270 LRS, at 41 kips
- 24 ~ 1/2" Ø, Grade 270 (Spec) LRS, at 34.0 kips
- 24 ~ 9/16" Ø, Grade 270 SR, at 35 kips
- 24 ~ 9/16" Ø, Grade 270 (Spec) SR, at 35.2 kips
- 28 ~ 1/2" Ø, Grade 270 LRS, at 29.0 kips
- 28 ~ 1/2" Ø, Grade 270 (Spec) SR, at 30.2 kips

NOTES:

1. Venting shall be provided by the use of a 1" Ø PVC conduit through a substructure cap or column. Voids between segments of spliced piles shall be connected by 2" Ø hole(s).
2. Any of the given Alternate Strand Patterns may be utilized. The strands shall be located as follows: Place one strand at each corner and place the remaining strands equally spaced between the corner strands. The total strand pattern shall be concentric with the nominal concrete section of the pile.
3. CONTRACTOR OPTION: The 30" pile may be cast SOLID by omitting the 18" Ø void, the 2" Ø holes and the 3/4" Ø vent holes. In this event, the Contractor shall submit calculations for approval and a proposed strand configuration that provide net prestressing after losses equal to 1000 psi.

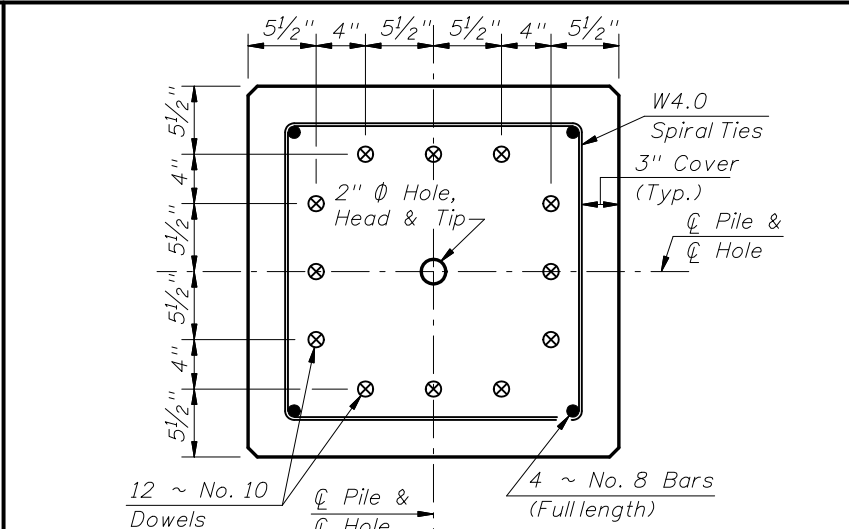

SECTION D-D

(See Non-Drivable Unforced Reinforced Precast Pile Splice Detail)

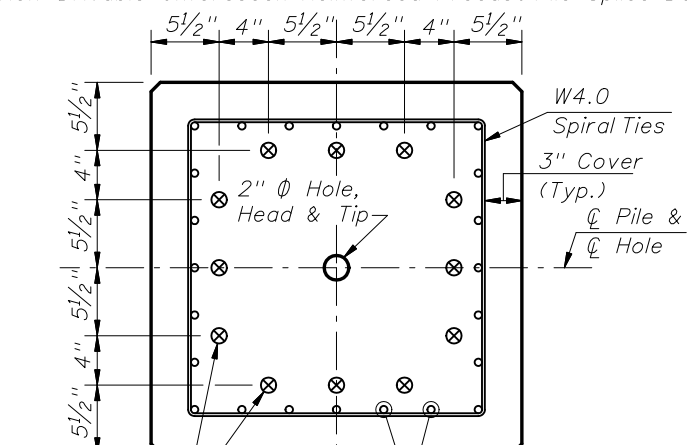

SECTION E-E

(See Drivable Prestressed Precast Pile Splice Detail)

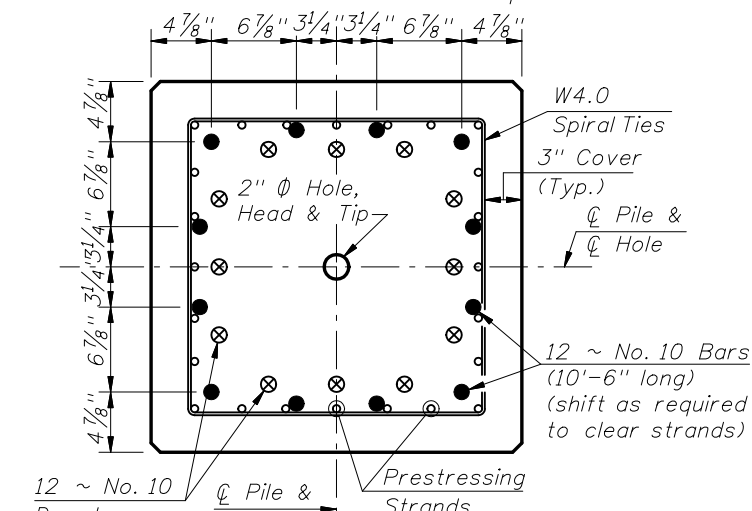

SECTION F-F

(See Drivable Prestressed Precast Pile Splice Detail)

PILE SPLICE DETAILS

REVISIONS

DATE	BY	DESCRIPTION	DATE	BY	DESCRIPTION
01/01/06	CEB	Added dimension "4'-0" Solid Section - Typical for Pile" & "11'-0" Solid Section - Typical for Splice Section" to ELEVATION.	11/07/06	LEJ	Deleted 2" Ø hole in tip solid section. Deleted 3/4" Ø hole in opposite sides of pile. Changed 4'-0" Solid Section to 11'-0" Solid Section & changed Note 1. Added "Head & Tip" to "2" Ø Hole" in PILE SPLICE DETAILS.

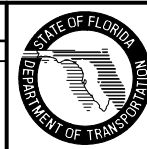

2006 Interim Design Standard

30" SQUARE PRESTRESSED CONCRETE PILE

Interim Date	Sheet No.
11/07/06	1 of 1
Index No.	
20630	