

# Landscape Inspection Seminar



This 2006 revision was carried out under the direction of

Jeff Caster, State Transportation Landscape Architect  
Florida Department of Transportation  
Environmental Management Office

Janna S. Glenn, RLA, Ph.D., ASLA  
Landscape Architect  
Hatch Mott MacDonald

Yvonne Collins, State Construction Training Administrator

# Intent

- ◆ Landscape Construction Inspector's goal is to verify that the Landscape Contractor has completed all the work according to FDOT Plans, Specifications, and Standards. Because landscape involves live plants that require not only proper installation procedures, but proper handling and care, the Inspector has to be aware of the factors that influence a successful completion of a particular job.
- ◆ The goal of this seminar is to introduce these factors, and to provide resources for reference and further study. At the end of the seminar, a short self-test will help you identify subject areas for which you may want to seek additional information.

# Course Organization

The following major topics will be introduced in this course:

- ◆ Plant Material Quality
  - ◆ Compliance with Division of Plant Industry regulations
  - ◆ Size
  - ◆ Grade
- ◆ Installation
  - ◆ Site preparation
  - ◆ Planting methods
- ◆ Establishment and Care
  - ◆ Symptoms of transplant shock, pest and disease problems, and injuries.

# Daily Inspection

- ◆ Inspector should be present at the project site during majority of the time the landscape is being installed.
- ◆ Daily observations are recorded in Daily Report of Construction (DRC).
- ◆ Reports should be submitted to the Project Administrator on a monthly basis.
- ◆ Any discrepancies between Plans and Specifications, and the work being performed must be recorded in the DRC and immediately reported to the Project Administrator.
- ◆ Basic requirements of Landscape Inspection are outlined in current Fiscal Year QC Category No. 14B Statewide Inspection List for Landscaping, available on the web:

<http://www.dot.state.fl.us/construction/CONSTADM/guidelist/guideindex.htm>

# Final Acceptance

- ◆ Although Final Acceptance is the responsibility of Project Administrator, the Inspector is required to be present at the final walk-through.
- ◆ Other individuals involved in final walk-through and Final Acceptance should include Landscape Architect, Contractor, and representatives of the municipality (if the municipality assumes maintenance responsibilities after Final Acceptance). These individuals should clearly communicate their questions and concerns at this time.
- ◆ General guidelines for Final Acceptance are described in Section 12.1 "Project Acceptance" of Construction Project Administration Manual:

<http://www.dot.state.fl.us/construction/manuals/cpam/CPAM70000000/cpamman.htm>

# FDOT Guidelines

- ◆ Final acceptance of a job is based on several FDOT publications that describe minimum standards for site preparation, plant size and quality, installation, and care during establishment:
  - ◆ Standard Specifications 162, 570, 580, 981, and 987.
  - ◆ Design Standards, Indices 104, 105, and 544.
- ◆ Plants have to be installed according to Roadway Plans and Design Specifications. For general information on reading plans, please see FDOT training course "Contract Plan Reading".
- ◆ In addition, some requirements, such as verifying tree grade, plant name, or health and vigor are not described in FDOT publications, but instead rely on Inspector's knowledge and ability to reference other sources. These sources will be provided in each section of this course.

# Florida State Guidelines

- ◆ All work has to comply with the following Florida Statutes:
  - ◆ Chapter 479.106 "Vegetation Management" prohibits plant installations in the view zone of a legally erected and permitted outdoor advertising sign. This statute also defines the view zone based on a posted speed.
  - ◆ Chapter 581.083 "Introduction or release of plant pests, noxious weeds, or organisms affecting plant life" prohibits installation of plants infected with pests or diseases, or sod contaminated with noxious weed plants or seed.
- ◆ Other Florida Statutes may be applicable, depending on the nature of the project.

# Plant Material Quality: Division of Plant Industry

- ◆ FDOT requires that all plants used for landscaping be purchased from Florida based nursery stock and comply with all required inspections and regulations. It is important to note that this means plants should be grown in Florida from Florida-based cuttings, liners, or seed. It is not appropriate to install plants sold by a Florida nursery which has purchased liners or seedlings from another state.
- ◆ Any discrepancies or errors should be reported to the Construction Project Administrator and noted in Daily Construction Log.



# Plant Material Quality: Division of Plant Industry

- ◆ The Division of Plant Industry (DPI) Bureau of Plant and Apiary Inspection publishes requirements for nursery registration and certification that can be found on <http://www.doacs.state.fl.us/pi/>
- ◆ Some of the main requirements include:
  - ◆ Registration of nursery with the DPI.
  - ◆ Inspection and approval of nursery stock by a Plant Protection Specialist of the DPI.
  - ◆ A valid inspection tag issued by the DPI on each separate package or bundle of nursery stock.

# Verifying Tree Size

- ◆ Small tree and shrub height and crown spread can be measured with a measuring tape or yardstick. For measuring large trees use a 25' surveying rod. Large trees can not be accurately measured with a yard stick or tape measure.
- ◆ Tree caliper is simply the diameter of tree trunk – for nursery trees this measurement is taken at 6" above grade. In order to accurately determine trunk diameter (without cutting the tree down), a specialized instrument, called a tree caliper, has been developed.
- ◆ Tree calipers (see next page) may come in different shapes and sizes, but the basic principle is the same. The instrument has one fixed and one movable arm, and a scale/ruler.

# Taking Caliper Measurements

- ◆ To measure the trunk, position the caliper arms so that the measuring points are held flush against the trunk, and read the measurement on the ruler. Take two measurements, at perpendicular directions, to get an average caliper for irregular trunks.
- ◆ Since tree trunks taper (reduce in diameter with height), a standard height for taking measurements is necessary. For nursery trees, take caliper measurements 6" above ground.



Image courtesy of Timothee Salin

# Taking Caliper Measurements

## DBH

Sometimes trees are specified with certain DBH, which stands for "Diameter at Breast Height". The procedure for taking this measurement is the same, the only difference is the height at which the measurement is taken. Take measurements at a height of 4.5 feet (an average person's chest height). As with any caliper measurements, take two measurements in perpendicular directions, and determine the average.

# Other Tools

The following tools may be helpful in evaluating a landscape installation:

Soil compaction gauge – used to determine soil compaction. Soil that is too compacted may result in slow root growth, or in extreme cases, prevent root penetration completely.

Image courtesy of John Sij, Texas Agricultural Experiment Station



# Other Tools

Soil probe – used to remove undisturbed samples of the soil profile for testing.



# Other Tools

Moisture meter – to determine if the plant's root zone is adequately moist.



# Confirm Plant Species

- ◆ FDOT requires that the plants used for landscaping are true to type and species.
- ◆ Further, a minimum of two plants of each species on each shipment must be shipped with tags stating the botanical nomenclature (scientific, or latin name) and common name of the plant.
- ◆ Plant tags should contain the minimum information required – name of the nursery/retailer, scientific name, and common name of the plant.



# Plant Quality

- ◆ Plants should never be handled by stem (or branches), always by rootball (or pot). It is possible for major roots or stem to fracture below the soil level, a defect that would not be detectable until a strong wind breaks the tree trunk completely.
- ◆ If the budget allows, all large trees (30 gallon or larger) should be tagged by the Landscape Architect at the nursery, to allow approval of trees before delivery to job site. Alternatively, a photograph of a minimum acceptable plant quality can be shared and agreed upon by the Contractor and Landscape Architect to provide a basis upon which plants are accepted or rejected.

# Plant Identification Resources

- ◆ FDOT requires that the plants used for landscaping are true to type and species. This is not an easy task, as some of the species are so similar in appearance that expert knowledge of plant morphology may be required to identify them. Such knowledge is beyond the scope of this seminar, but the list of resources below may be helpful in identification of a particular plant. These websites provide scientific and common names, cultural requirements, and photographs of plants.
  - ◆ USDA PLANTS Database: <http://plants.usda.gov/>
  - ◆ Floridata – Encyclopedia of Plants and Nature: <http://www.floridata.com/>
  - ◆ Horticipia: <http://www.horticipia.com>
  - ◆ Atlas of Florida Vascular Plants: <http://www.plantatlas.usf.edu/>

# Florida Grades and Standards for Nursery Stock

- ◆ Florida Grades and Standards for Nursery Stock was developed to improve the quality of plants reaching job sites. It defines quality of trees in terms of structure and health, and thus affects longevity of tree in the landscape and increases safety to future users.
- ◆ Florida Grades and Standards for Nursery Stock is published by Florida Department of Agriculture and Consumer Services, Division of Plant Industry:  
<http://www.doacs.state.fl.us/pi/plantinsp/publications.html>

# Florida Grades and Standards for Nursery Stock

- ◆ **FDOT installations must use ONLY Florida #1 grade or better quality plants.** Trees must be planted as #1 and remain a minimum #1 quality until final acceptance. It is not acceptable to plant lesser quality trees in hopes that by the end of the project they would grow into #1 trees.
- ◆ To understand exactly what Florida #1 tree should look like, we will also discuss Florida Fancy (better quality than #1, acceptable) and Florida #2 (worse quality compared to #1, not acceptable) grades, but not a cull (unacceptable quality trees).

# Florida Grades and Standards for Nursery Stock

- ◆ Because many factors have to be considered in grading a tree, it may be a difficult process, and sometimes disputes arise when a nursery and Inspector can not agree on a grade of a particular tree.
- ◆ In such a case, a request for a formal re-grading inspection should be made in writing to the Chief Plant Inspector, Division of Plant Industry, P.O. Box 147100, Gainesville, Florida 32614-7100.
- ◆ To qualify for a re-grading inspection the plants in question must have originated from a nursery that is currently registered and under inspection by the DPI and the plants in question must not have been at the landscape site for more than 30 days. The 30 day requirement is to insure that the plants are in the same condition at the time of the inspection as they were when delivered to the landscape site by the nursery.



# Florida Grades and Standards for Nursery Stock

Of course, it is best to avoid as many disputes as possible. In order to further assist nurserymen and landscape professionals in understanding tree grading the following aids have been developed:

- ◆ Florida Chapter International Society of Arboriculture took the lead to establish a Certified Nursery Tree Grading program that aids implementation of the Florida Grades and Standards for Nursery Trees and Palms. This program trains consultants and others to provide certification that nursery stock meets a specified grade.
- ◆ Roots Plus Growers publishes a Tree Grading Cue Card. This small, laminated field reference guide is useful for remembering the basic principles of tree grading. You may obtain a free copy of Tree Grading Cue Card by visiting [www.rootsplusgrowers.com](http://www.rootsplusgrowers.com)

# Tree Grading Cue Card

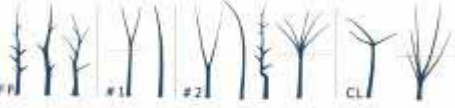
**Tree Grading Cue Card**  
provided by Roots Plus Growers™

- Look inside the crown of the tree at the trunk form.
 
- Check branch arrangement.
 
- Choose appropriate tree matrix type.
  - Type 1- spreading and rounded shapes.  
ex. live oak, dogwood, black olive, gumbo limbo
  - Type 2- pyramidal shapes.  
ex. river birch, bald cypress, cedar, pine
  - Type 3- columnar / upright shapes.  
ex. East Palatka holly, schefflera, Italian cypress
  - Type 4- vase shapes.  
ex. crape-myrtle, buttonwood, ligustrum, redbud
  - Type 5- oval shapes.  
ex. red maple, podocarpus, tabebuia, dathon holly

Refer to the matrix tables in the Grades and Standards when necessary to determine proper root ball size, container size, crown spread, and height.
- Measure the caliper of the trunk.
 

Trunk caliper is measured 6 inches from the ground on trees up to and including 4 inches in caliper, and 12 inches above the ground for larger trees. Diameter at 4 1/2 feet (DBH) is not considered an appropriate measurement for nursery trees.
- Grade the tree based on crown spread.
 

If the crown spread does not look proportional to the tree, use the matrix table you selected above along with the trunk caliper measurement to determine the crown spread for the tree. For this step, select a grade based on crown spread only.
- Grade the tree according to structural uniformity.
 
- Make note of the lowest grade determined in steps 1, 2, 5, and 6.

- Reduce grade determined in step 7 by one grade if any **one** of the following is true.
  - Tree with a trunk caliper >1" needs a stake to hold it upright.
  - The root ball or container is undersized. (consult tree matrix)
  - B&B root ball is not properly pinned, tied or wired.
  - Tree is excessively root-bound.
  - Evidence of large roots growing out of container (1/3 trunk diam)
  - Crown is thin and sparsely foliated. (allow for harvesting time of year)
  - More than 5% of branches have tip dieback.
- Reduce grade determined in step 8 by one grade if **two** of the following are true.
 

If only one is true, do not reduce the grade. However, it takes only **one** true statement to reduce a Florida Fancy to a Florida #1. If more than two of the following are true reduce the grade by two.

  - Tree height is not in proper proportion. (consult tree matrix)
  - Flush cuts were made when pruning branches from the trunk.
  - Branch stubs are left beyond the branch collar.
  - Open trunk wounds or other bark injury is evident.
  - Graft unions are not complete.
  - More than the lower 40% of the trunk is free of branches.
  - More than 5% of canopy is chlorotic/peet & disease damaged.
  - Most leaves are smaller than normal.
  - Included bark between main trunks or trunk and major branch.
  - Trunks and/or major branches are touching.
- Tree is a cull if it has a root greater than 1/10th the diameter of the trunk circling around more than 1/3rd of the trunk in the top half of the root ball.

## Important Grading Notes

- Remember that grading a tree should be a quick process. Once you are familiar with the process it should only take a few seconds to grade a single tree.
- When grading small maturing trees such as crape-myrtle, coffee guava, wax privet, yaupon holly, lignum-vitae, wax myrtle or other small-maturing trees skip steps 1, 2, and 4.
- Trunks do not have to be straight to be a Florida Fancy or Florida #1. See drawings for Florida Fancy and Florida #1 in step one.
- A trunk dogleg is defined as a significant 's'-shaped deformation in the trunk. This is illustrated in the figure to the right. The angle 'A' can be no more than 30°. The distance 'B' can be no more than the trunk diameter.
 

This tree grading cue card was provided to you courtesy of the Roots Plus Field Growers Association of Florida

**ROOTS PLUS GROWERS**

Growing Quality Field-Grown Trees  
www.rootsplusgrowers.org

This Tree Grading Cue Card is available from Roots Plus Growers.

You may download a free copy of this card at [www.rootsplusgrowers.com](http://www.rootsplusgrowers.com)

# Tree Grade Tag



This tree grade tag is issued by International Society of Arboriculture.

Image courtesy of Timothee Salin, Cherry Lake Tree Farm



# Grades and Standards: Trunk

- ◆ Large-maturing trees should have just one dominant trunk through the center to the top of the tree.
- ◆ Small trees normally grown with multiple trunks (crepe myrtle, buttonwood, river birch) are allowed.
- ◆ Branch diameter should not be larger than  $\frac{2}{3}$  diameter of the trunk (measured directly above the branch).
- ◆ Consult appropriate Grades and Standards matrix for crown spread (depends on species and trunk caliper, see next page for an example).

# Grades and Standards: Tree Matrix

EXAMPLES	TYPE ONE MATRIX — SPREADING & ROUNDED SHAPES									EXAMPLES
	CALIPER	MINIMUM TREE HEIGHT	MAXIMUM TREE HEIGHT	MINIMUM CROWN SPREAD DIAMETER			MINIMUM B&B ROOT-BALL DIAMETER	MINIMUM GROW BAG ROOT-BALL DIAMETER	MINIMUM CONTAINER VOLUME	
				FL. FAN	#1	#2				
apple, pitch-bauhinia bay, red-camphor tree carambola citrus dogwood, flowering fig, fiddle-leaf fig, rusty fig, weeping floss silk tree goldenrain tree gumbo limbo holly, round kapok laurel, Cuban-lychee loquat	1/4"	18"	30"	10"	8"	6"	6"	—	4" Sleeve	mahoe mango mangrove, black oak, laurel oak, live oak, sand live oak, water oak, white olive, black-olive, spiny black-pagoda tree, Japanese rubber tree, Indian-sausage tree shaving brush tree silk-cotton tree, red sycamore tamarind weeping willow
	1/2"	24"	6'	14"	12"	8"	8"	—	1 Gal.	
	3/4"	4'	8'	30"	24"	18"	14"	—	3 Gal.	
	1"	5'	10'	36"	30"	24"	16"	12"	5 Gal.	
	1 1/4"	6'	11'	42"	36"	30"	18"	14"	7 Gal.	
	1 1/2"	7'	12'	48"	42"	34"	20"	16"	15 Gal.	
	2"	8'	15'	54"	48"	42"	24"	18"	15 Gal.	
	2 1/2"	9'	16'	60"	54"	48"	28"	18"	25 Gal.	
	3"	10'	18'	66"	60"	54"	32"	20"	45 Gal.	
	3 1/2"	11'	18'	6'	5 1/2'	5'	36"	24"	65 Gal.	
	4"	12'	22'	7'	6 1/2'	6'	40"	30"	95 Gal.	
	4 1/2"	14'	24'	8'	7 1/2'	7'	44"	36"	95 Gal.	
	5"	16'	26'	10'	9'	8'	48"	36"	95 Gal.	
	5 1/2"	17'	28'	11'	10'	9'	50"	—	200 Gal.	
	<b>Notes:</b> 1. Trees to be graded under this matrix are listed in the index of trees on pages 37-44. 2. Any liner less than 1/4" caliper shall be a minimum of 12" in height, well-rooted in its container which shall not be less than 2" in diameter. Bare-root trees shall be so noted. 3. Ball depth on B&B stock shall be at least 2/3 of the root-ball diameter shown. For trees larger than 5 1/2" caliper, root-ball diameter shall be 8.5" for each inch of tree caliper. Trees grown in soils with a high water table can have shallower root balls provided the root-ball diameter is increased to the next larger tree size in the table. 4. Red or black mangrove may be a minimum of 18" overall height in a 1-gallon container, 24" overall height in a 3-gallon container. 5. For the purpose of determining minimum root-ball size, cured trees can have a caliper up to 1" larger than indicated in the table. 6. ANZI Standards Z60.1 designations for container size (e.g. #3, #15, #30, etc.) can be substituted for minimum spread diameter									

In this example, a 1" caliper oak should have height between 5' - 10', minimum crown spread of 2.5', grown in a 5 gallon container, or larger.

This and all following images from Grades and Standards are used with permission from Richard A. Clark, Chief of Bureau of Plant and Apiary Inspection

# Grades and Standards: Trunk

## Florida Fancy:

- ◆ One trunk more or less in the center of the tree.
- ◆ Trunk is straight or has a bow less than 5% (some species excepted).
- ◆ Tip of the leader is intact and terminal bud is the highest point of the tree.
- ◆ No branch has diameter greater than  $\frac{2}{3}$  of trunk diameter measured directly above branch crotch.

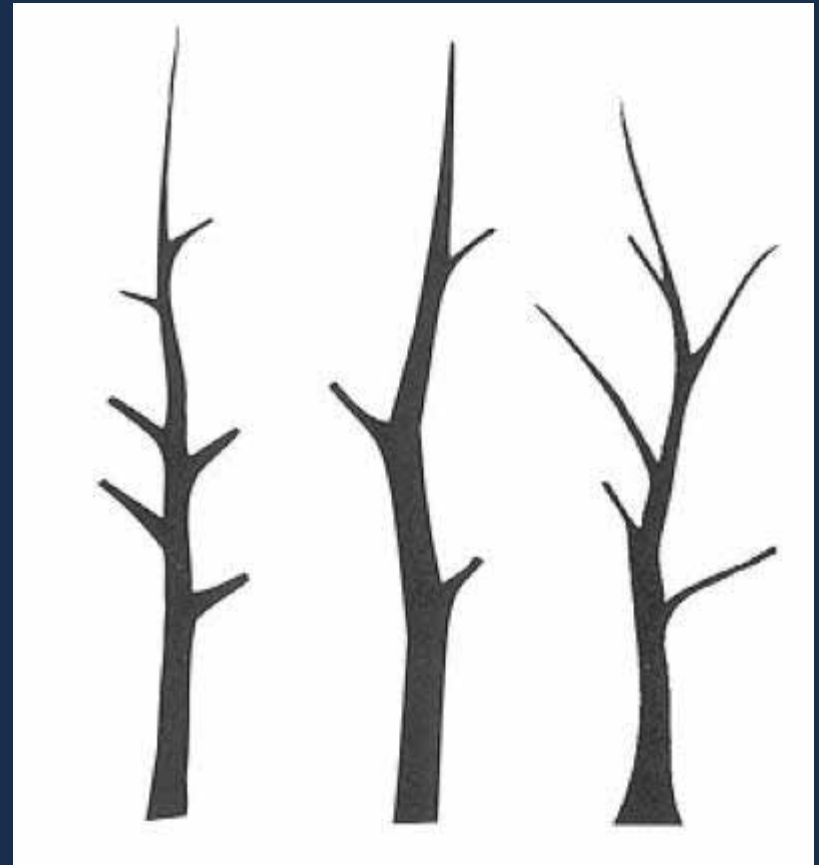

# Grades and Standards: Trunk

## Florida #1:

- ◆ Trunk forks into two nearly-equal diameter trunks in the upper ½ of the tree.
- ◆ Only one trunk is present, but it bows 5-15%.
- ◆ Tip of the leader is intact and terminal bud is the highest point of the tree.

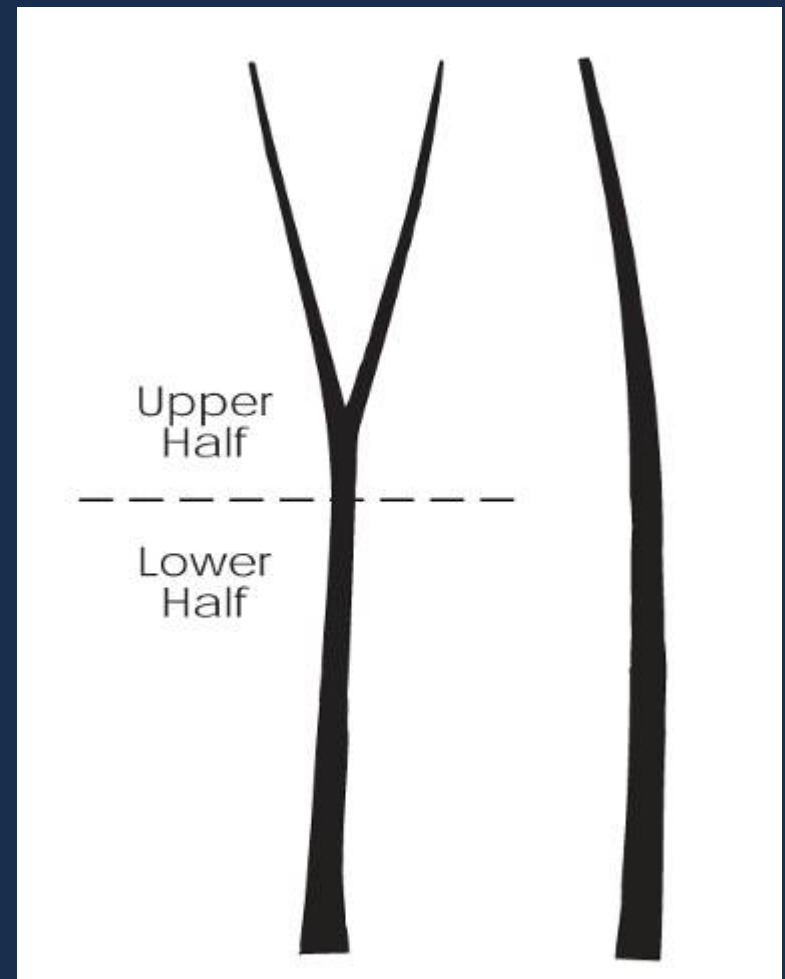

# Grades and Standards: Trunk

## Florida #1:

It is important to understand that since every tree is a unique living individual, the Grades and Standards document allows certain imperfections:

- ◆ If the trunk divides in two nearly equal-diameter stems in the upper 10% of the tree, the trunk is not downgraded to a Florida #1 (for that reason alone).
- ◆ Shade trees do not have to have straight trunks in order to meet Florida #1 grade, a dominant leader is enough. Please note that a degree of bow is allowed (up to 15% from vertical).

# Grades and Standards: Trunk

## Florida #2:

- ◆ Trunk forks into two nearly-equal diameter trunks in the lower ½ of the tree.
- ◆ Or, trunk branches into three or more nearly-equal diameter trunks in the upper ½ of the tree.
- ◆ Only one trunk is present, but it bows more than 15%, or has a dogleg below canopy. Trees with a dogleg in the canopy are not downgraded.

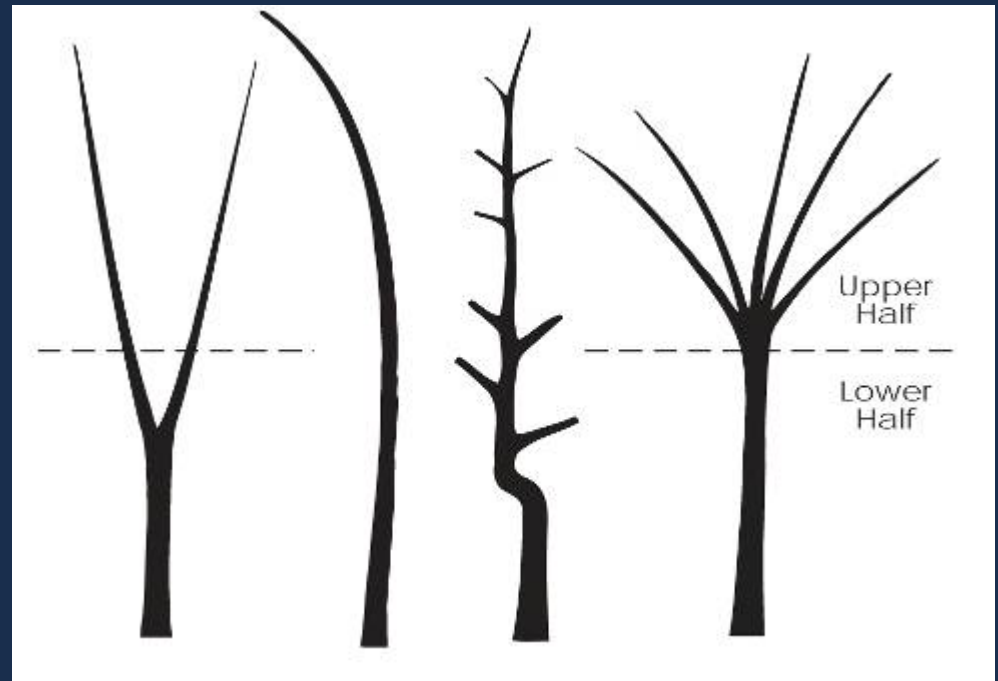

# Grades and Standards: Branch Arrangement

## Florida Fancy:

- ◆ Several branches are larger in diameter (and obviously more dominant) than others.
- ◆ Dominant branches are spaced more than 6" apart along the trunk.
- ◆ No major branches are oriented nearly vertical.
- ◆ Temporary branches on the lower trunk may not be larger than 1/5 diameter of the trunk.

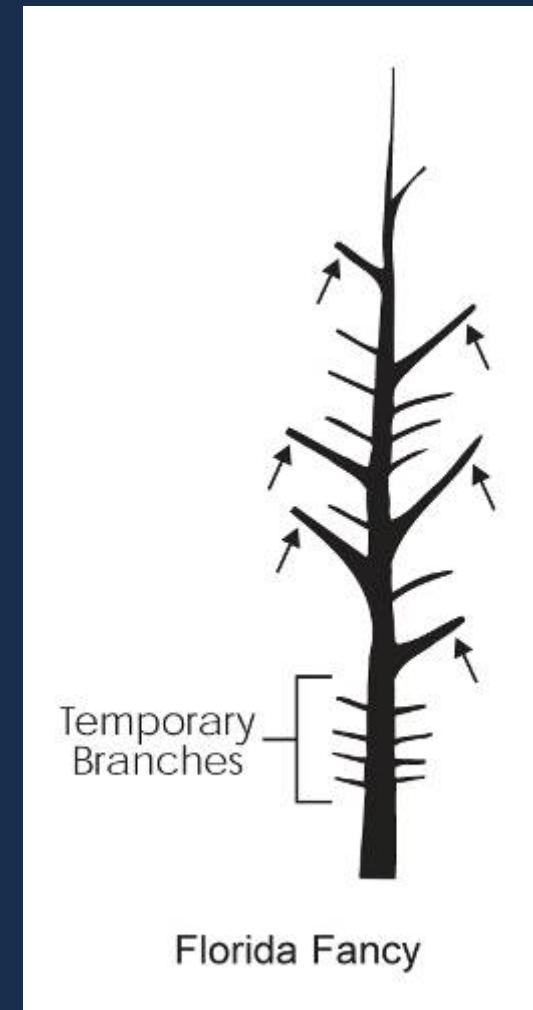

# Grades and Standards: Branch Arrangement

## Florida #1:

- ◆ All branches are approximately equally dominant.
- ◆ Or, there are dominant branches, but two are nearly equal in diameter and spaced less than 4" apart. Other major branches are more than 4" apart.
- ◆ No branch tips are taller than the trunk.
- ◆ See page 4 of Grades and Standards for list of species exempt from this requirement.





# Grades and Standards: Branch Arrangement

## Florida #2:

- ◆ Most major branches are oriented vertically.
- ◆ Nearly equal diameter branches are located within 4" of each other at two or more positions on the trunk (see arrows).
- ◆ One or more branches in the lower half of the tree are larger than  $\frac{2}{3}$  of the trunk diameter measured directly above that branch.



# Grades and Standards: Crown Uniformity

## Florida Fancy:

- ◆ Branches are evenly distributed around the trunk.
- ◆ No major branch is located directly above another.
- ◆ Crown is full of foliage, evenly distributed.

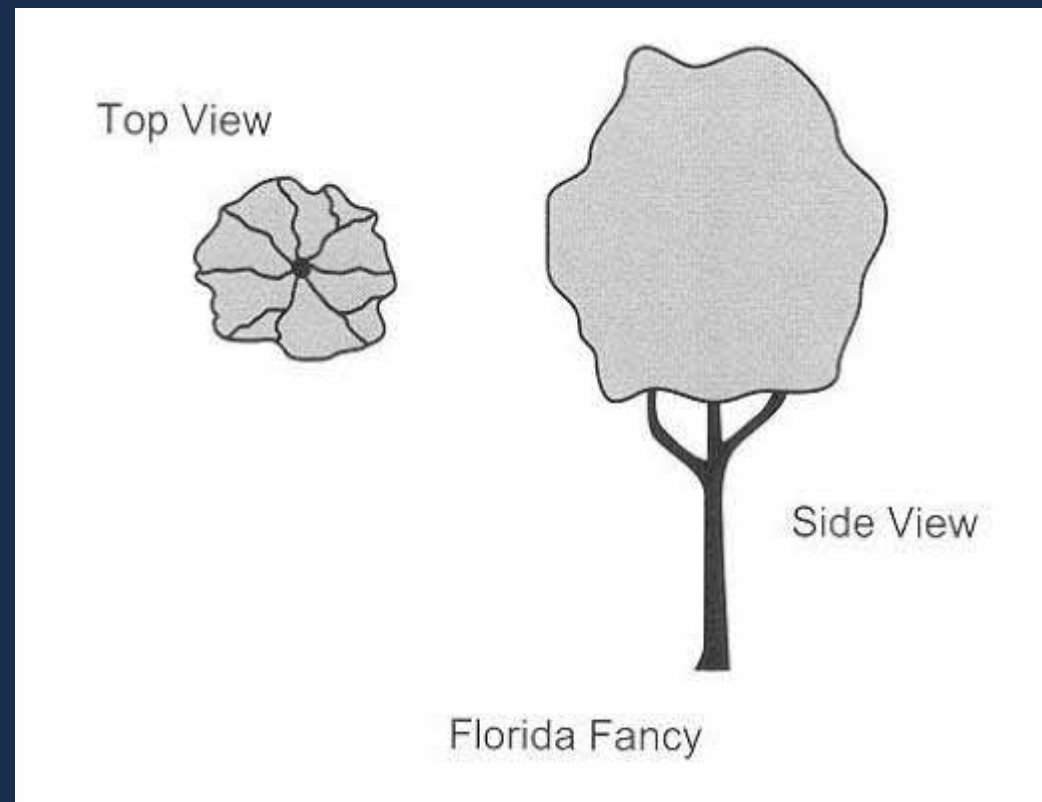

# Grades and Standards: Crown Uniformity

## Florida #1:

- ◆ One major branch may be located directly above another; other branches are evenly distributed.
- ◆ Crown is not completely full of foliage and may have small voids.

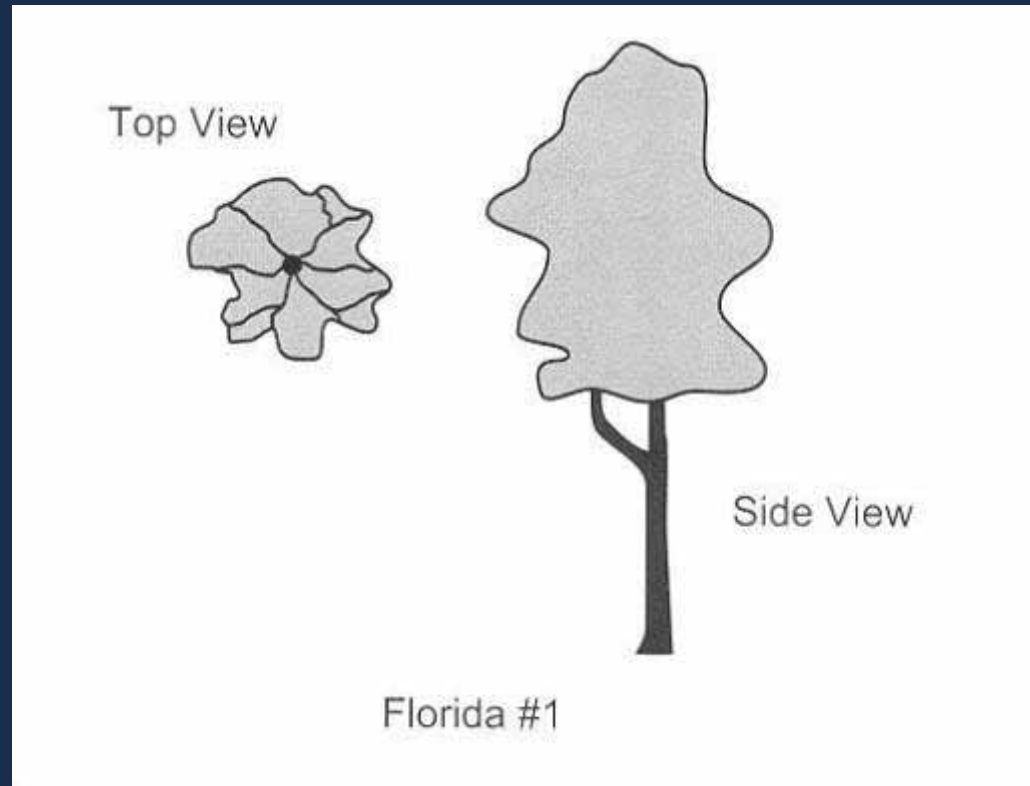

# Grades and Standards: Crown Uniformity

## Florida #2:

- ◆ Branches are not evenly distributed around the trunk.
- ◆ Several branches are growing from the same side of trunk.
- ◆ Two or more branches may be located directly above others.
- ◆ Crown has a large void.

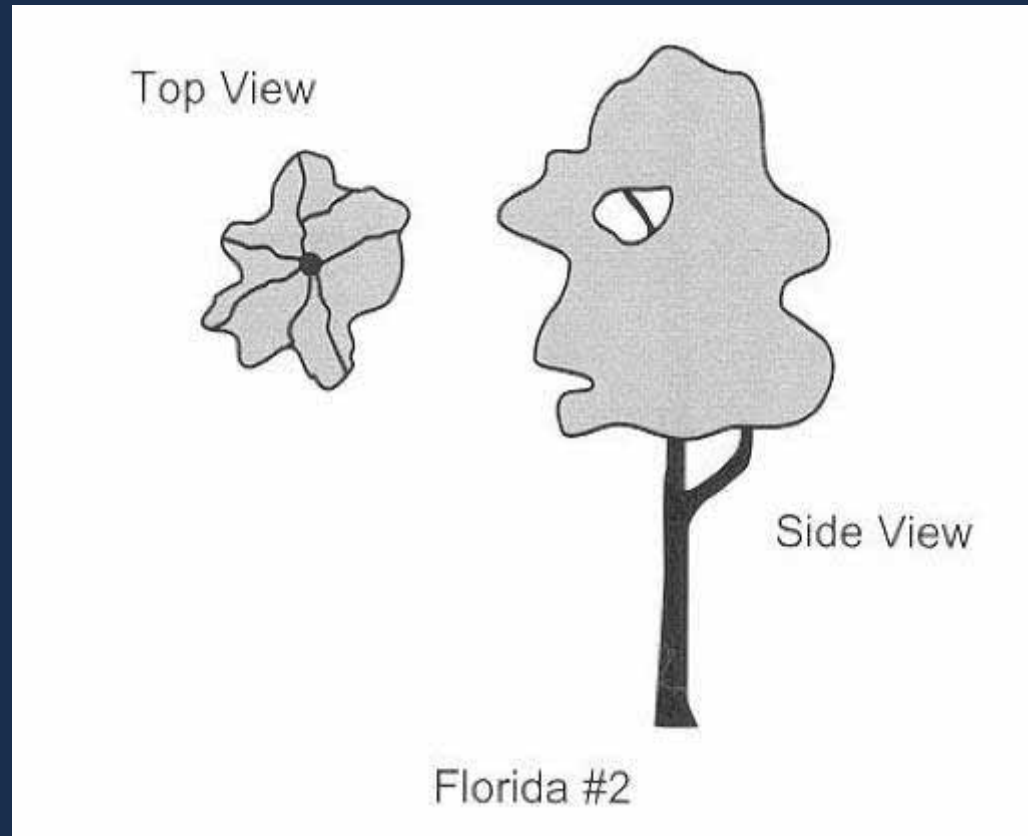

# Grades and Standards: Pruning Cuts

## Correct Pruning Cut:

- ◆ Cuts made above branch collar (tissue swelling at the base of each branch). Correct cut is illustrated with a dash line.
- ◆ Pruning scar is nearly circular.
- ◆ Wound is well healed and is surrounded by a ring of callus (woundwood).

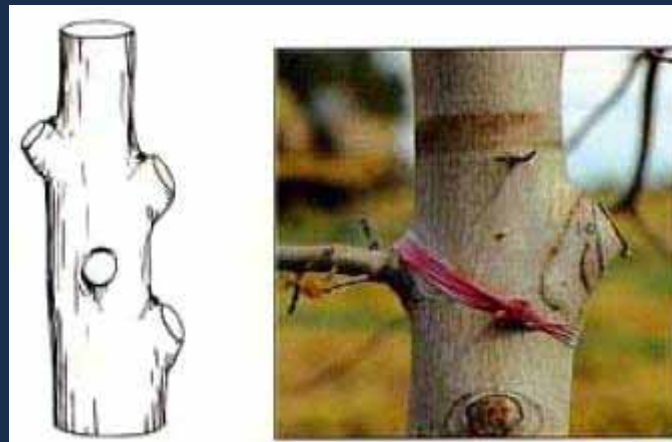
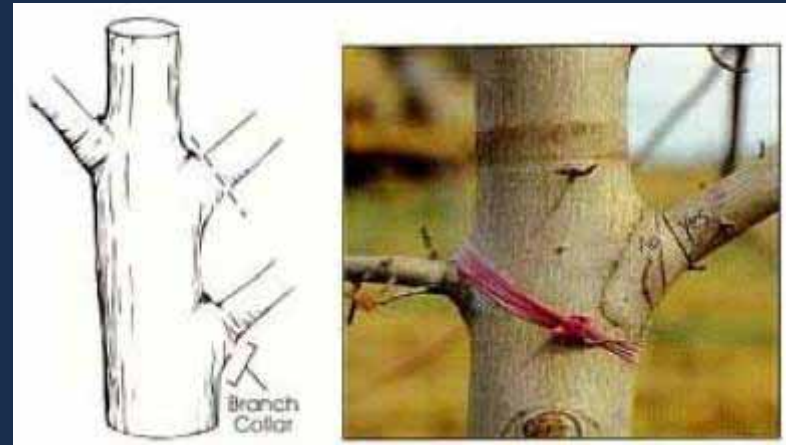

# Grades and Standards: Pruning Cuts

## Incorrect Pruning Cut:

- ◆ Cuts made below branch collar
- ◆ Pruning scar is oval.
- ◆ Callus is often missing from the wound.
- ◆ Signs of trunk decay may be visible.

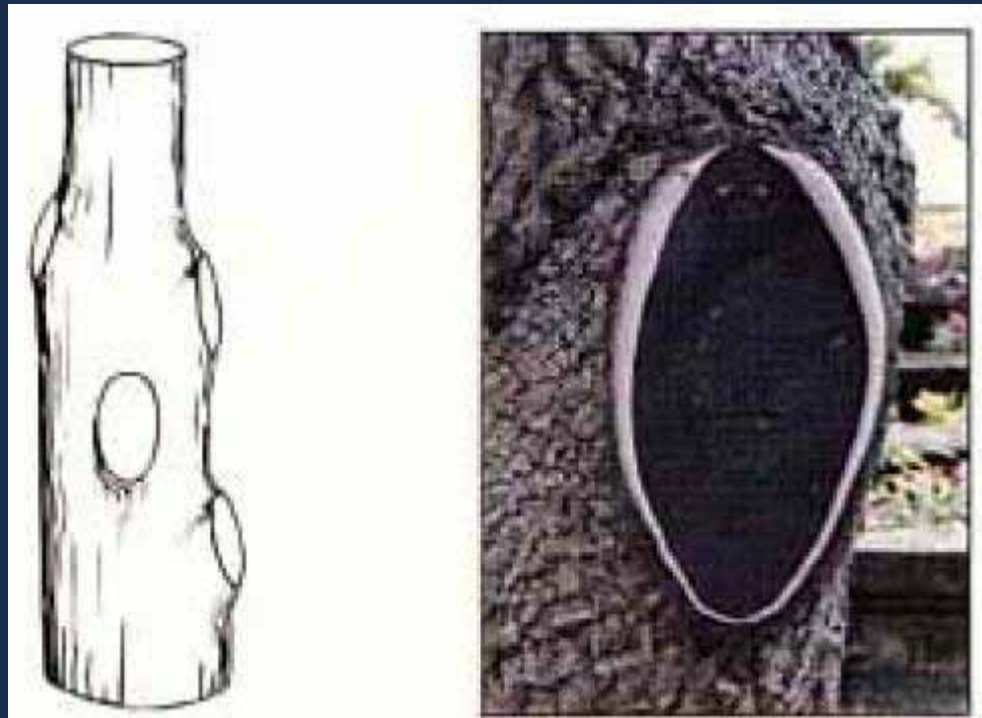

# Grades and Standards: Florida Fancy

- ◆ Single, straight trunk
- ◆ Uniform branch distribution throughout the crown
- ◆ Uniform crown with full foliage
- ◆ No flush cuts evident



# Grades and Standards: Florida #1

- ◆ Trunk divides into two equal-sized trunks in the upper ½ of the tree (although hard to see in the photograph).
- ◆ Branches are well spaced along the trunk
- ◆ Crown is fairly uniform and full of foliage





## Grades and Standards: Florida #2

- ◆ Trunk divides into two equal-sized trunks in the lower ½ of the tree
- ◆ Crown is sparse, with many openings



# Grades and Standards: Palms&Cycads

To correctly grade a palm, first determine an appropriate matrix by selecting an appropriate Palm Category and Type (such as B-2 or A-3):

## Palm Categories:

- A – Single-trunk with pinnate leaves.
- B – Single-trunk with palmate leaves.
- C – Clustering types.

## Trunk Types:

- 1 – Slender trunk.
- 2 – Moderate trunk.
- 3 – Heavy trunk.

Consult “Grades and Standards” for minimum mature height and minimum root ball size.

# Grades and Standards: Palms&Cycads

All palm leaves are compound, with many leaflets arranged into one structure. It is easy to determine whether a palm has a palmate or pinnate type leaf, if you look at the structure of an individual leaf (see next page):

- ◆ In "pinnate" leaves the segments/leaflets are parallel to each other and attached to a long midrib, like the segments of a feather (thus the name).
- ◆ "Palmate" means the leaflets radiate out from a single point, like the fingers from the palm of a hand, or the segments of a collapsible hand fan

# Grades and Standards: Palms&Cycads



Pinnate Leaf (left):  
Note the resemblance of  
the leaf structure to a  
feather.



Palmate Leaf (above):  
Looks similar to an open  
hand, or a hand fan.

# Grades and Standards: Palms&Cycads

## Florida Fancy:

- ◆ An exceptionally healthy and vigorous palm that is perfectly formed and foliated (subject to the natural growth of species).
- ◆ Meet or exceed caliper specifications (found in appropriate Matrix).
- ◆ Well formed, with no abrupt changes in caliper (unless typical of species).
- ◆ No holes, cavities, or other defects.
- ◆ Heavy canopy with all petioles in ascending position, and 75% excellent leaves.
- ◆ No pests, disease or sunburn symptoms.
- ◆ No extreme succulence (tender new growth typical of shade-growing or overfertilization).
- ◆ Clustering palms are symmetrical and well-formed.

# Grades and Standards: Palms&Cycads

**Unacceptable Conditions:** If even one of these eliminating factors is present, the specimen is rendered NOT gradable and is not acceptable.

- ◆ General, overall chlorosis (yellowing of leaves).



Chlorosis of coconut palm.

Image courtesy of S. Nelson, University of Hawaii

# Grades and Standards: Palms&Cycads

**Unacceptable Conditions:** If even one of these eliminating factors is present, the specimen is rendered NOT gradable and is not acceptable.

- ◆ Bacterial or fungal crown rots (discoloration of crown tissues, slimy, rotted appearance, foul smell, drooping and dead leaves).



Crown rot on cycad – notice soft, discolored (dark) scales.

# Grades and Standards: Palms&Cycads

**Unacceptable Conditions:** If even one of these eliminating factors is present, the specimen is rendered NOT gradable and is not acceptable.

- ◆ Wood or crownshaft boring insects or damage (watch for holes in trunk, oozing fluid, extruded fiber and insect droppings).



Image courtesy of S. Nelson,  
University of Hawaii



# Grades and Standards: Palms&Cycads

**Unacceptable Conditions:** If even one of these eliminating factors is present, the specimen is rendered NOT gradable and is not acceptable.

- ◆ Holes, cavities or gouges (consult "Grades and Standards" for matrix-specific maximum size).
- ◆ Under-size root ball (according to an appropriate matrix).
- ◆ Palms improperly staked using nails in trunk.
- ◆ In mature palms, caliper less than specified for class (Matrix A&B only).

# Grades and Standards: Palms&Cycads

Although some degree of damage is allowed on palms, learn to recognize symptoms of lethal yellowing (LY), a serious disease rapidly spreading in Florida. All trees believed to be infected with LY should be reported to Division of Plant Industry for professional evaluation.

This disease was first noticed in the Caribbean region of North America about 100 years ago, that more recently has spread to other areas of Florida and into Texas. There is no cure for lethal yellowing, although the palms native to Florida are generally resistant to this disease.

The early symptoms of LY include fruit drop and blackening of flower stalks. Then palm fronds start to yellow (or, in the case of some species, turn greyish-brown), beginning with the older, lower fronds and progressing up through the crown (hence the name). Finally, the top leaf and bud die and the trunk is left bare. Trees die very quickly – within 3-6 months from the appearance of first symptoms.

# Grades and Standards: Palms&Cycads

## Lethal Yellowing:



Early symptoms of flower stalk blackening.



Discoloration and death of older fronds.

Eventual death of the palm.

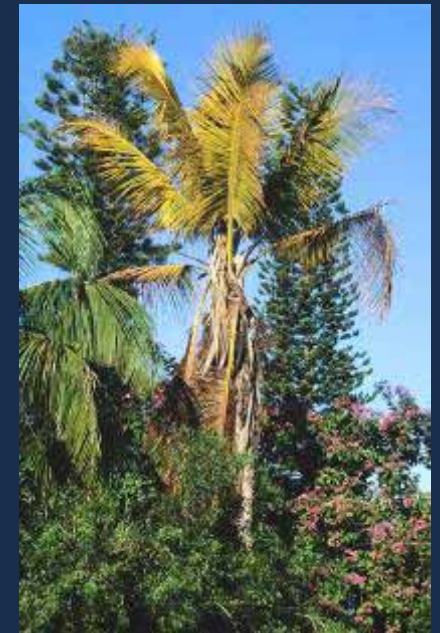

Images property of Doug Caldwell, IFAS, University of Florida , Collier Co. Extension. Used with permission.

# Grades and Standards: Palms&Cycads

## One-Grade Deductions:

- ◆ Abrupt changes in caliper not typical of the species.
- ◆ For each, hole, cavity, gouge or depression, less than 1" wide or 3" long or ½" deep.
- ◆ Live insects or insect damage.
- ◆ Leaf spots exceeding 10% of leaf surface.
- ◆ Chlorosis exceeding 10% of leaf surface (excluding the oldest leaf).
- ◆ Crooked or bent trunk, unless typical of the species or specified by contract.
- ◆ Extreme succulence.
- ◆ Rugged or torn boots, or scarring of trunk caused by tearing off boots prematurely (Matrix B&C only).
- ◆ Cluster not balanced or symmetrical, or number of main trunks is not proportional to the total number of intermediate trunks.

# Grades and Standards: Palms&Cycads

Total 'Yes' responses to "One-Grade Deductions":  
0=Florida Fancy; 1=Florida #1; 2=Florida #2; 3=Not Gradable



Florida Fancy



Florida #1



Florida #2  
(unacceptable)

# Planting Bed Preparation

Any type of installation requiring excavation (such as digging planting pits for trees) must take into account locations of underground utilities. Before beginning any type of excavation, contractor should mark the area of work with white marking materials and then contact Sunshine State One-Call of Florida, Inc. (SSOCOF) 1-800-432-4770 to request excavation site “locates” for underground utilities. This is required by “Underground Facility Damage Prevention and Safety Act”, Chapter 556, F.S.

Small planting pits (for small trees and shrubs, less than 2' deep) should be excavated by hand.

# Planting Bed Preparation

Planting bed (soil) preparation is discussed in Standard Specification 162 "Prepared Soil Layer". Main emphasis of this Specification is placed on assuring proper pH and organic matter content of the soil to a depth of 6".

Full text of this Specification is available on the Web:

<http://www.dot.state.fl.us/specificationsoffice/2007BK/162.pdf>

Please note that in the future this Specification will be expanded to include soil preparation for trees (and greater depth of prepared soil layer). It will also require that planting pits drain freely (this drainage condition should be enforced now, to prevent root rot).

# Planting requirements: Index 544

In 2006, the outdated one-page Index 544 was replaced by a comprehensive three page document, based on input from FDOT District Landscape Architects, the latest research by University of Florida faculty and International Society of Arboriculture.

The new Index 544 takes into account plant size and form, adds another level of detail and clarifies tree staking and guying, as well as adding an option of planting trees with underground wooden stakes (cross-braces).



# Index 544: Tree Planting

The following general rules apply to all planting:

- ◆ Planting pits for trees and shrubs on level ground should be at least twice as wide as the rootball diameter, and no deeper than the depth of rootball. Rootball should be set on existing undisturbed soil.

The reason for specifying the minimum size of a planting pit, is to assure initial root growth in loosened backfill.

The reason for digging a planting pit no deeper than the depth of a rootball, is to prevent soil settling under the rootball, which will eventually cause the plant to be planted deeper than the intended depth. Existing undisturbed soil will have minimum settling, compared to backfill, which will reduce in volume with watering and pressure from tree weight.

# Index 544: Tree Planting

- ◆ On slope, planting pits for trees and palms are only 6" wider than the rootball (on all sides). Shrub planting pit should be the same size as for planting on level ground (twice as wide as the rootball diameter).

The reason for limiting planting pit size on slope, is to limit soil disturbance, and to avoid erosion to the maximum extent possible.

Shrub planting pits are considerably smaller, so the difference is minimal and it is not necessary to make this distinction.

# Index 544: Tree Planting

As discussed previously, even existing undisturbed soil will tend to settle somewhat under the pressure of tree weight. It is a good rule of thumb to set trees slightly higher to counteract this effect:

- ◆ Regardless of production type (container or Balled and Burlapped), top surface of tree rootballs should always be set 1"-2" above grade, to allow for soil settlement. Remove containers, cages and at least top 1/3 of burlap.

Containers have to be removed because they will not decay for years and will prevent or significantly limit root growth into the surrounding soil. Wire cages will girdle trunk and major roots. Natural burlap is biodegradable, and the roots can easily grow through the spaces between threads.

# Index 544: Tree Planting

- ◆ Trees should be set plumb to the horizon (exactly vertical).

This is especially important when planting on slope – check trunk position with a level or a plumb (weight tied to a string), rather than just visually.

# Index 544: Tree Planting

Containers, synthetic burlap, and wire cages should be removed completely. Biodegradable burlap should be removed from at least 1/3 of the rootball.

In addition, roots of container-grown trees should be inspected and combed or pruned if pot-bound. Severely pot-bound trees or trees with large girdling (circling the trunk) roots should be rejected.

To check installations, excavate the roots with an air gun. If not available, carefully remove top soil with a plastic trowel.

# Index 544: Tree Planting

- ◆ Backfill for trees should always be loosened existing soil.

In the past compost and other amendments were recommended as additives to the planting soil. Recent research has shown that in amended backfill tree roots may have difficulty penetrating into surrounding existing soil. The result is a confined root system and a poorly adapted tree, less likely to survive strong winds or periods of drought.

Very large stones and other debris should be removed from backfill. Naturally occurring smaller stones are not a problem, and may even improve planting pit drainage.

# Index 544: Tree Planting

- ◆ Trees should have a soil ring formed of existing soil at the edge of the planting hole.

This soil ring will help collect irrigation water and rain, and reduce runoff. Please note that configuration of soil ring is affected by whether or not the planting site is level.

On level sites, the soil ring is continuous along the entire edge of the planting pit. On sites with a slope of 1:6 or steeper, the soil ring should be only on the downslope from the tree – to catch runoff. There should not be any soil mounded on the upslope – otherwise water would be directed away from the planting pit, where it is needed.

# Index 544: Tree Planting

- ◆ All trees should be mulched with 3" of approved mulch (measured after settlement). Keep mulch away from the trunk (mulch to the edge of trunk flare).

Approved mulch materials include pine bark chips, pine needles, compost and some inorganic materials (which usually require approval of the Engineer).

Mulch should not be piled on too thick – like the dreadful “volcanoes” sometimes seen around trees. Too much of a good thing may cause reduced water and oxygen penetration to the roots. Mulch piled on next to the trunk will increase chances of rot and insect damage.



# Index 544: Tree Planting

- ◆ Above-ground guying systems should be attached to the trunk at a level between  $1/2$  to  $2/3$  of the tree height.

Locating guying below  $1/2$  of the tree height may not allow enough leverage to support the tree. Locating guying above the  $2/3$  of the tree's height may put too much stress on the upper, thinner, and weaker part of the tree, and cause damage.

# Index 544: Tree Planting

- ◆ Guying material in contact with the tree should be strong, soft, pliable, and flexible inorganic material, securely fastened to strapping.

Material in direct contact with the tree trunk may injure bark because of the movement in the wind and rubbing of the material against bark. Softer materials help prevent this injury.

As a tree grows, its trunk diameter will increase, and the guying system may put too much pressure on the trunk, causing girdling, weakening, and even death. This is also a reason why guying systems should be inspected and adjusted periodically, and removed completely within one year from planting.

# Index 544: Tree Planting

Tree girdled by rope  
guying system.



# Index 544: Tree Planting

- ◆ All aboveground wooden stakes or earth anchors should be located beyond the edge of the soil ring.

This is required to ensure that the support system is anchored in existing, firm soil. Backfill within the planting pit is too loose, and the stakes, or anchors, can be pulled out easily.

# Index 544: Tree Planting

- ◆ Strapping should be made of material manufactured to withstand outdoor conditions and support tree for the life of the guying system.

Some of the materials suitable for strapping include nylon ties, cables, and synthetic rope. Keep in mind that these materials are attached to a soft and flexible guying material, and not to the tree trunk.

Materials chosen for strapping should withstand UV radiation (sun), moisture, and wind forces for the period of establishment (approximately one year).

# Index 544: 1"-3.5" Caliper Tree Planting

- ◆ Note the plan view of the tree planting to the right, showing locations of support stakes and guying material.
- ◆ Note that the support stakes are located outside of the planting pit, firmly secured in the existing soil. Safety flags are permanently attached to each stake.

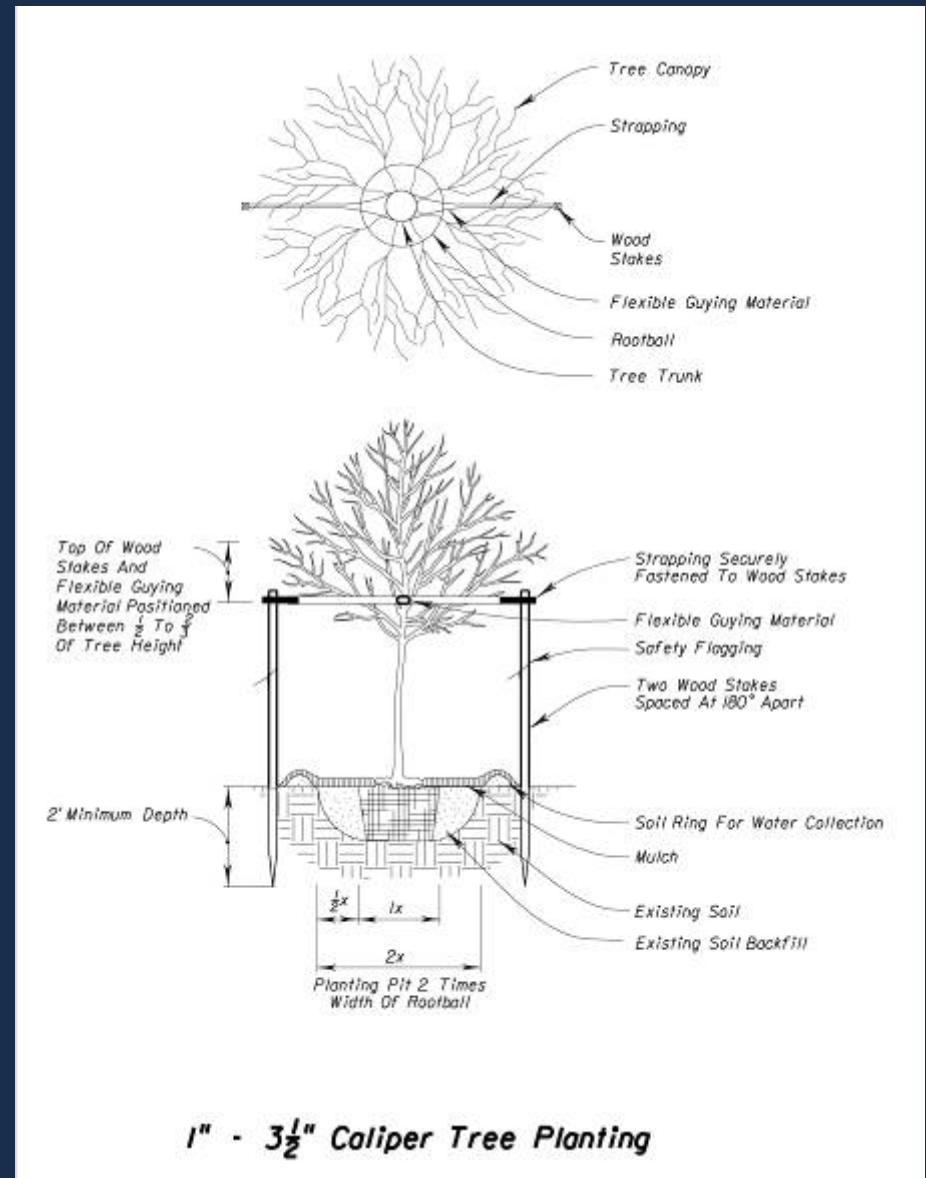

# Index 544: 1"-3.5" Caliper Tree Planting



Correctly planted 1"-3.5" tree.

# Index 544: 4" and Larger Caliper Tree Planting

- ◆ The only difference in planting larger trees is the guying system. Trees 4" in caliper and larger are secured using three wood anchors, driven under ground at an angle. Strapping is secured to the anchors and to the flexible guying material at the trunk. Flexible guying material is positioned between  $\frac{1}{2}$  to  $\frac{2}{3}$  of tree height.
- ◆ Note safety flagging attached to each strap.

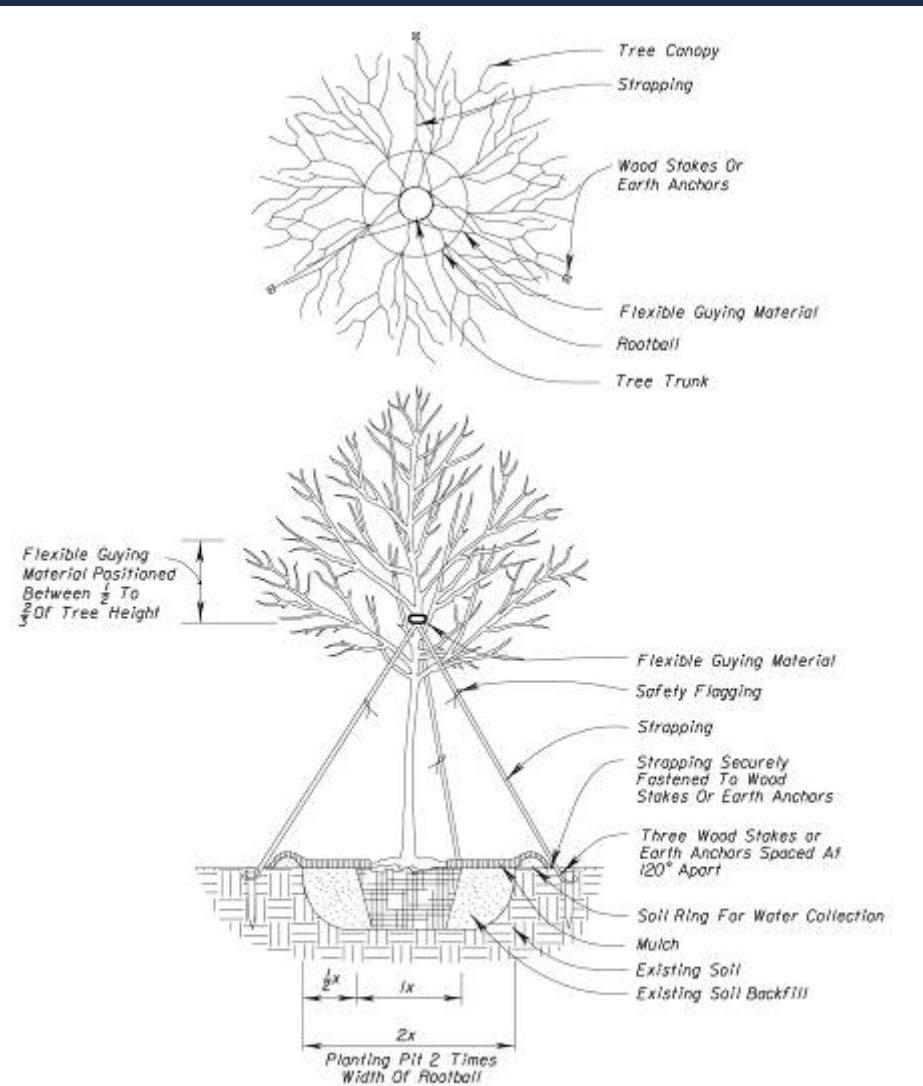

**4" and Larger Caliper Tree Planting**



# Index 544: 4" and Larger Caliper Tree Planting

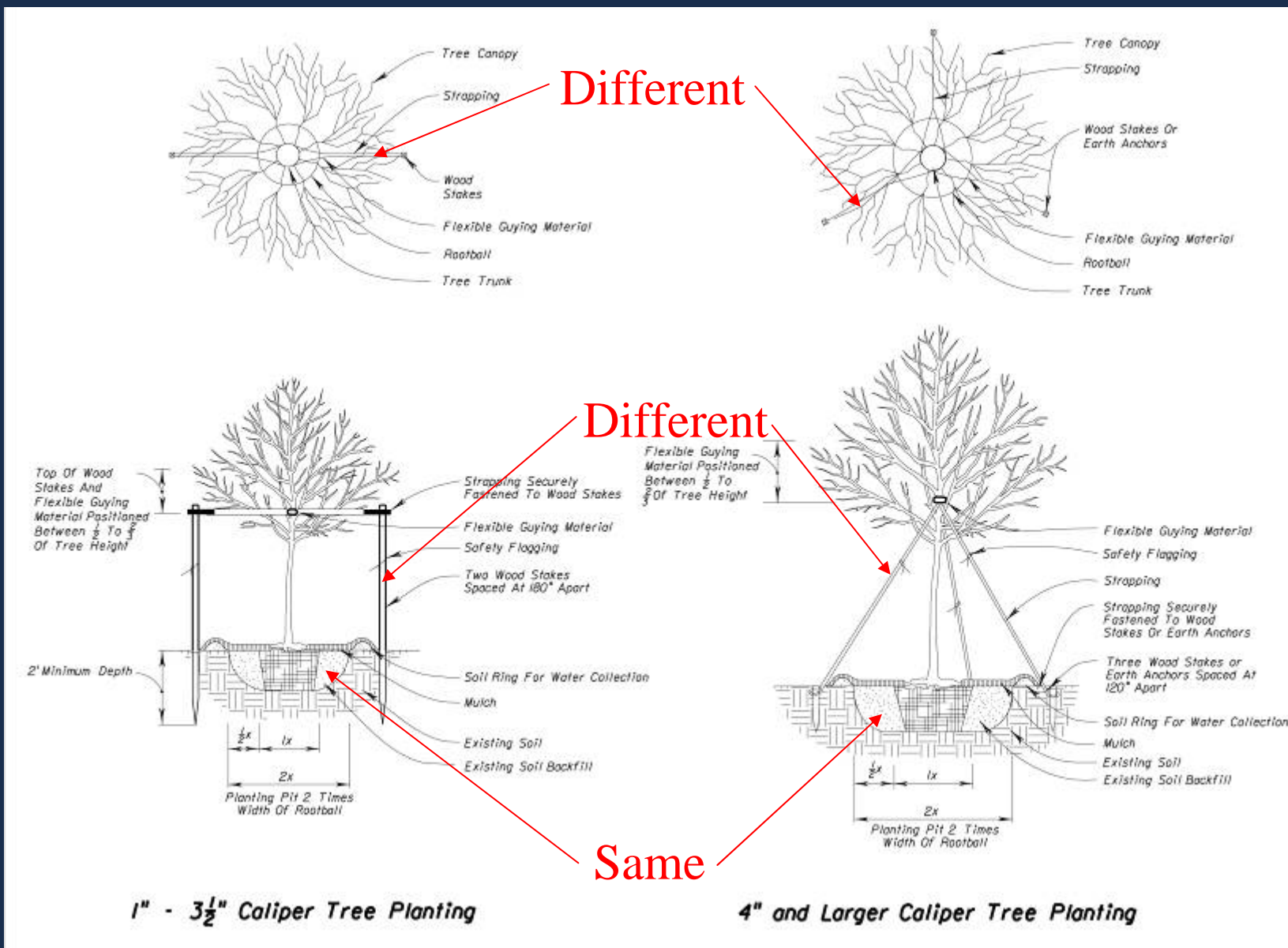

# Index 544: Tree Planting With Wooden Stakes.

- ◆ Again, the only difference from the previous types of tree planting is the guying system. This guying system is located completely underground.
- ◆ Two wooden cross-braces (minimum size 2 x 2) are nailed to vertical wooden stakes, located at the edges of rootball and driven into the firm existing soil below, to the minimum depth of 3.5'.
- ◆ To check if the installation was performed correctly, remove upper soil layer with air gun or plastic trowel.

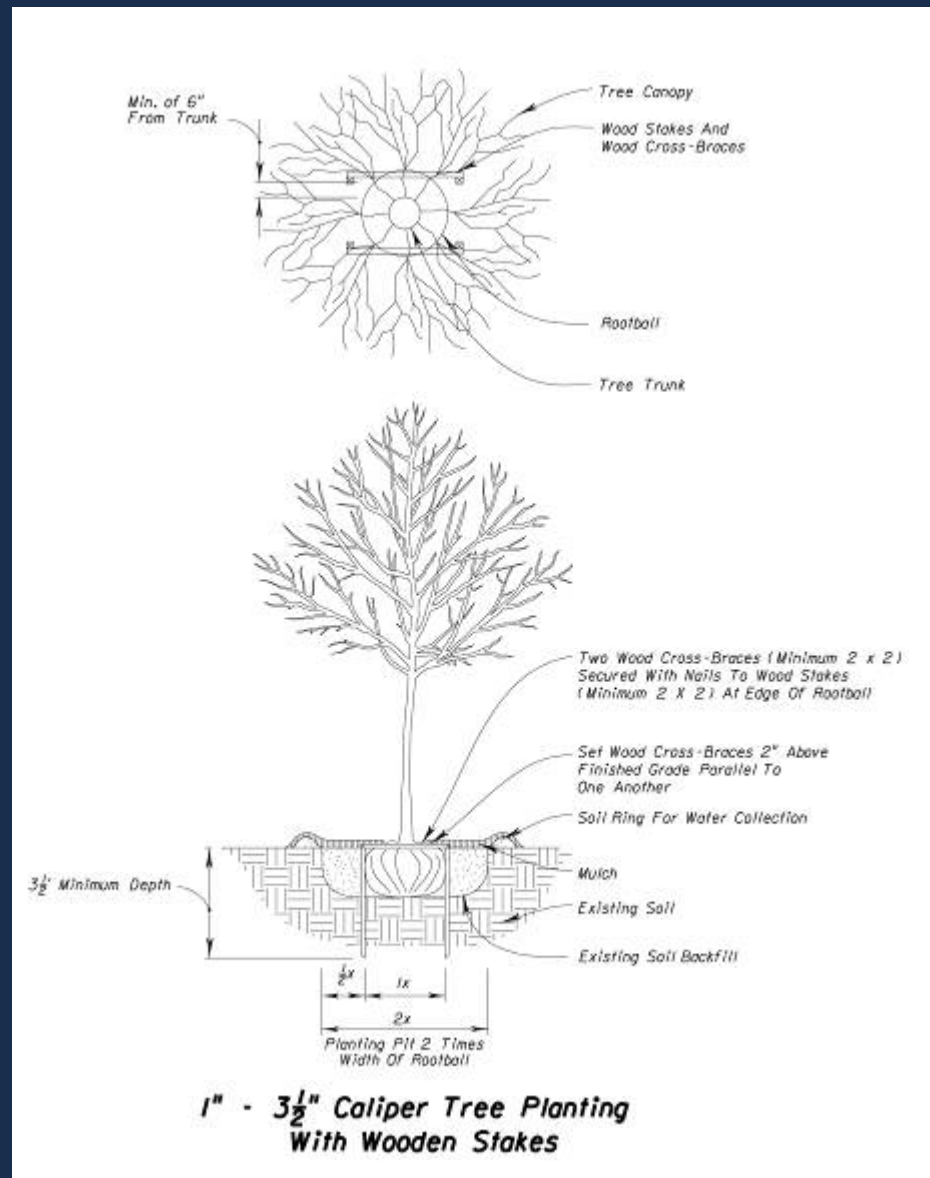

## Index 544: Tree Planting on Slope (1"-3.5" Cal.).

- ◆ Here the main difference from the small tree planting on flat ground is the size of planting pit and configuration of the soil ring. Note that while support stakes should be driven minimum 2' into the soil, the actual length may be different, to accommodate slope.

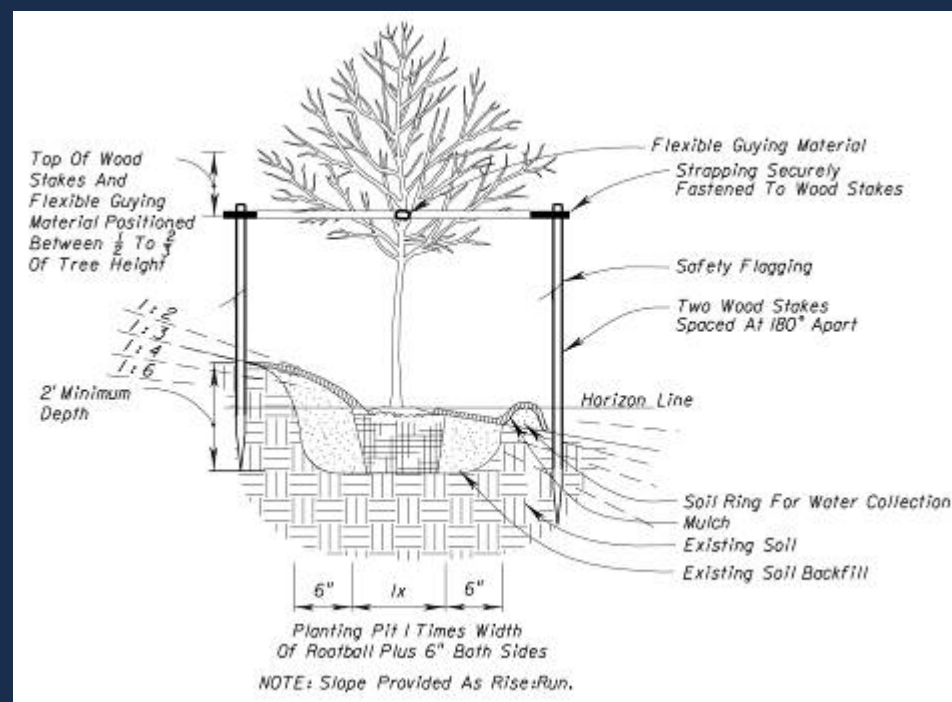

- ◆ The planting pit is potentially smaller, just 6" wider on all sides than the rootball (as compared to 2x rootball diameter). This is to reduce native soil disturbance and erosion potential.

## Index 544: Tree Planting on Slope (1"-3.5" Cal.).

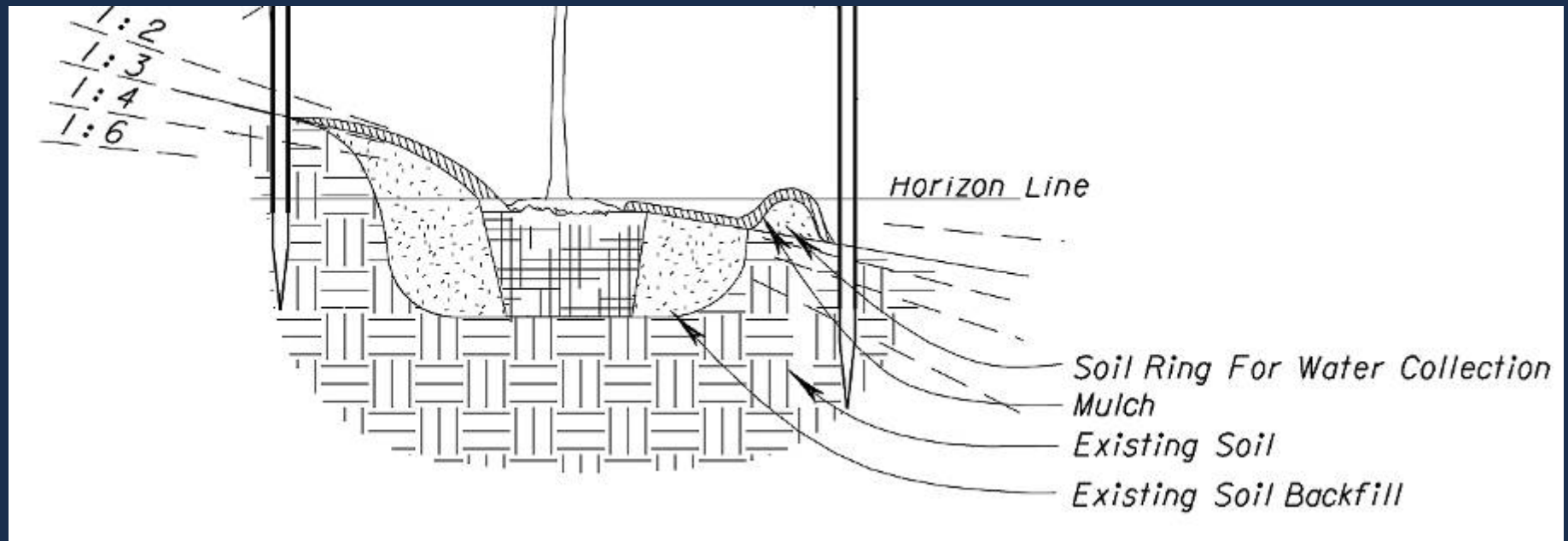

- ◆ Soil ring is constructed only down the slope from the tree, to collect runoff and reduce erosion. Top of the soil ring should be level with the base of the tree (flare) and mulched to prevent erosion.
- ◆ Height of the soil ring depends on the slope - to be level with tree base, soil ring will be taller with steeper slope.

## Index 544: Tree Planting on Slope (4" + Cal.).

- ◆ When planting 4" and larger caliper trees on slope, guying system will remain the same as for 4" caliper trees planted on flat ground.
- ◆ Again, the main difference from planting on level ground is the size of planting pit and configuration of the soil ring (as previously described for 1"-3.5" caliper trees).

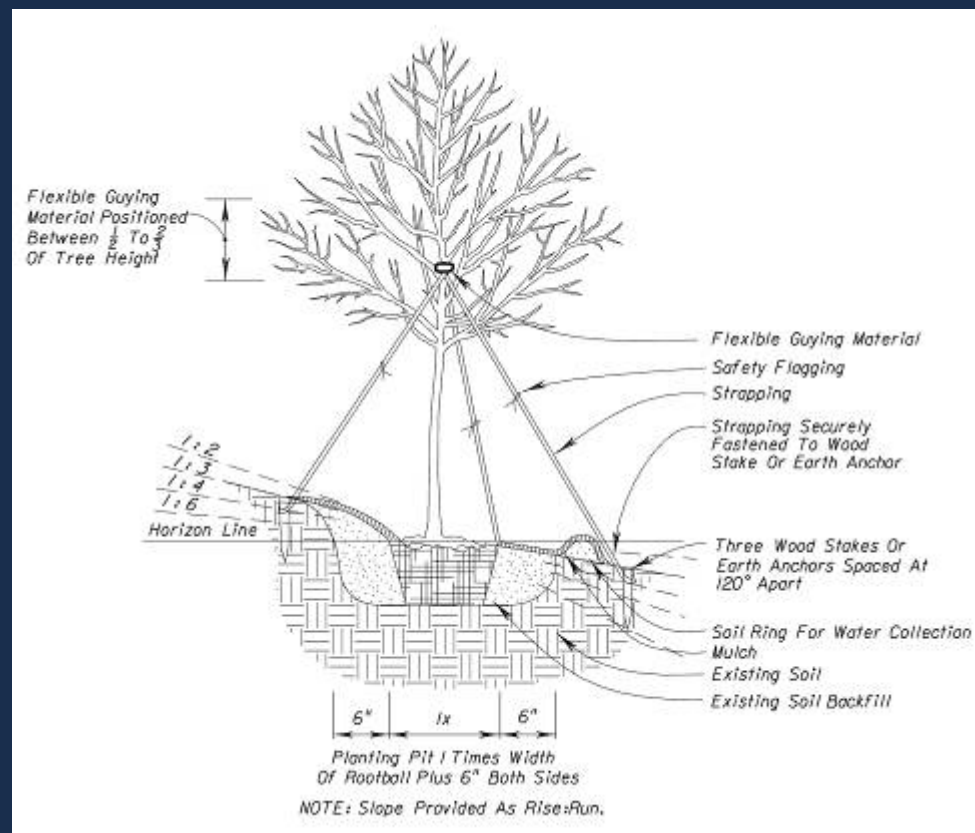

# Index 544: Multi-Trunk Tree Planting.

- ◆ The only difference between planting single-trunk trees and multi-trunk trees is the guying system.
- ◆ Guying system is similar to small caliper (1"-3.5") trees with the following exceptions:
  - ◆ Three stakes are installed instead of two (equally spaced).
  - ◆ Each strap is attached to a different branch on the main trunk taking care to not pull the crown apart.

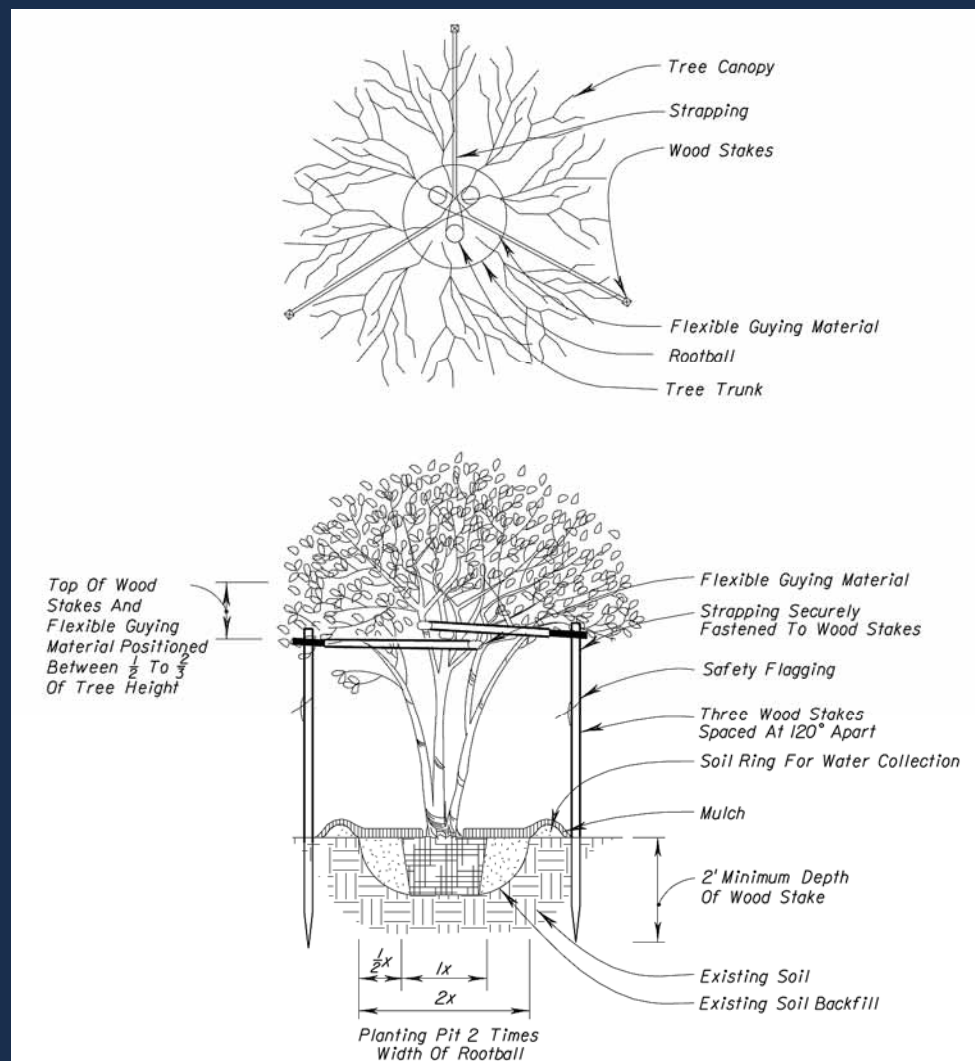

# Index 544: Multi-Trunk Tree Planting.

- Note the similarities and differences between the small tree and multi-trunk tree planting methods.

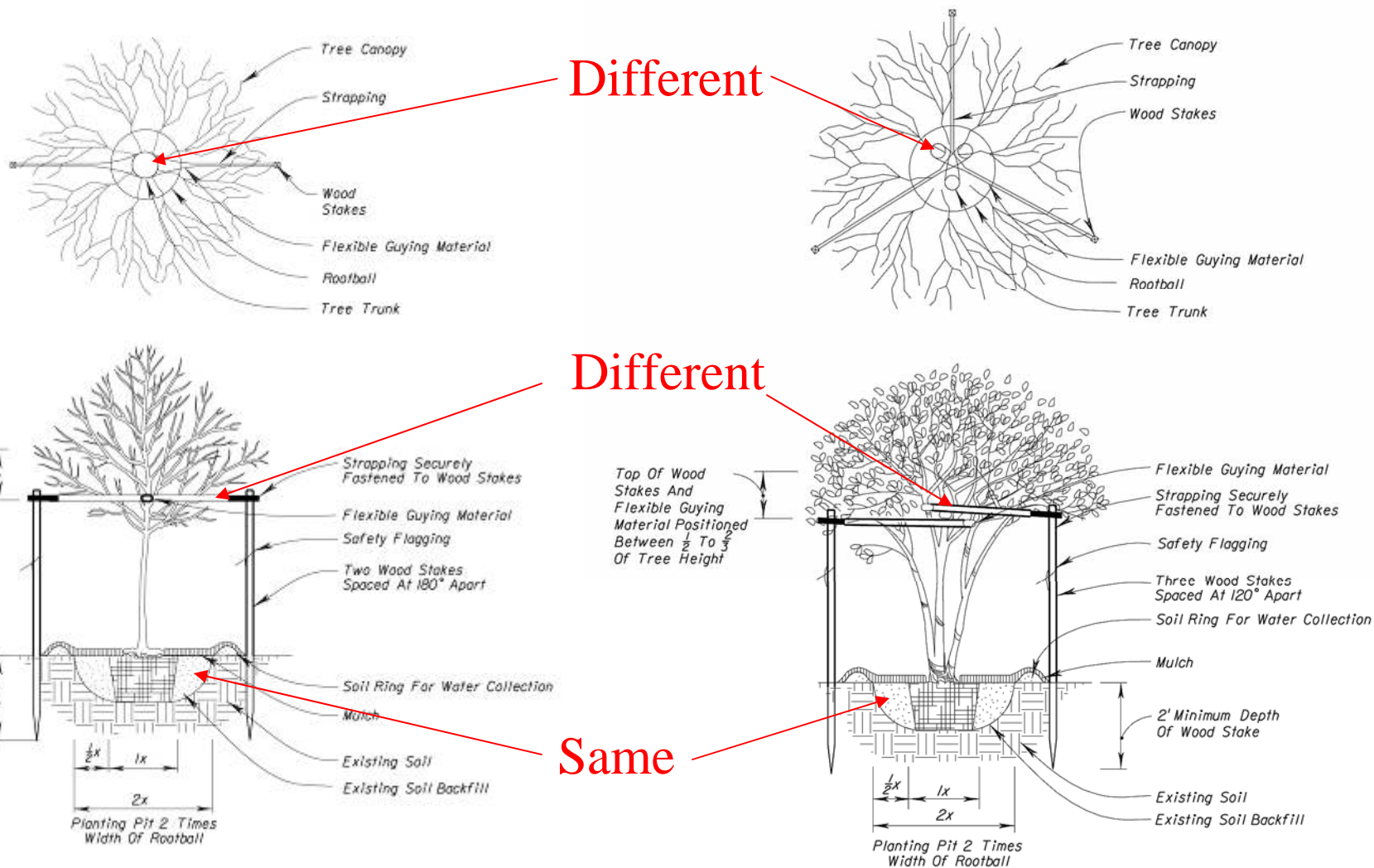

# Index 544: Palm Planting.

- ◆ The main difference between tree and palm planting is the guying system.
- ◆ At least 3 (or 4) wooden braces, equally spaced around the trunk, should be securely nailed to earth anchors and wooden batten (see following slides for details). Care should be taken so that the batten or nails are never in direct contact with trunk.

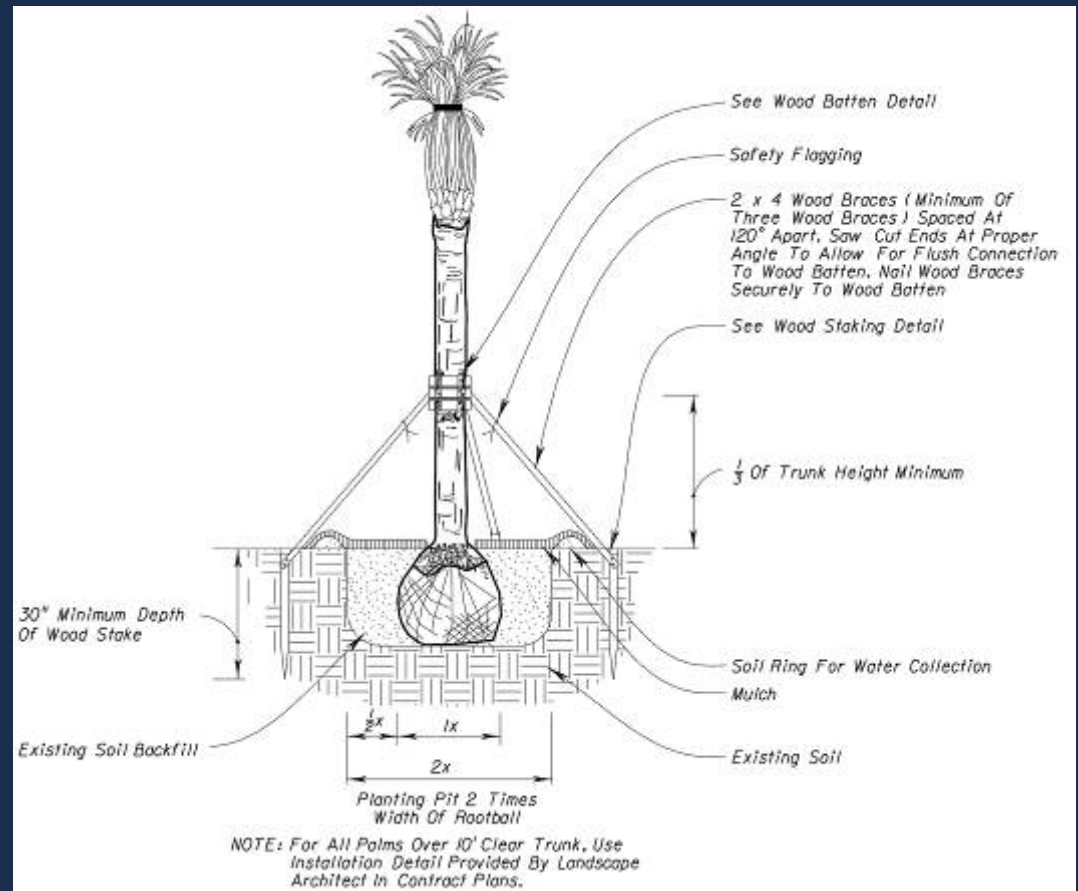

- ◆ Sabal palms may be hurricane cut, while others should have fronds tied with biodegradable strap.



## Index 544: Palm Planting.



Correctly planted palm grouping.

# Index 544: Palm Planting.

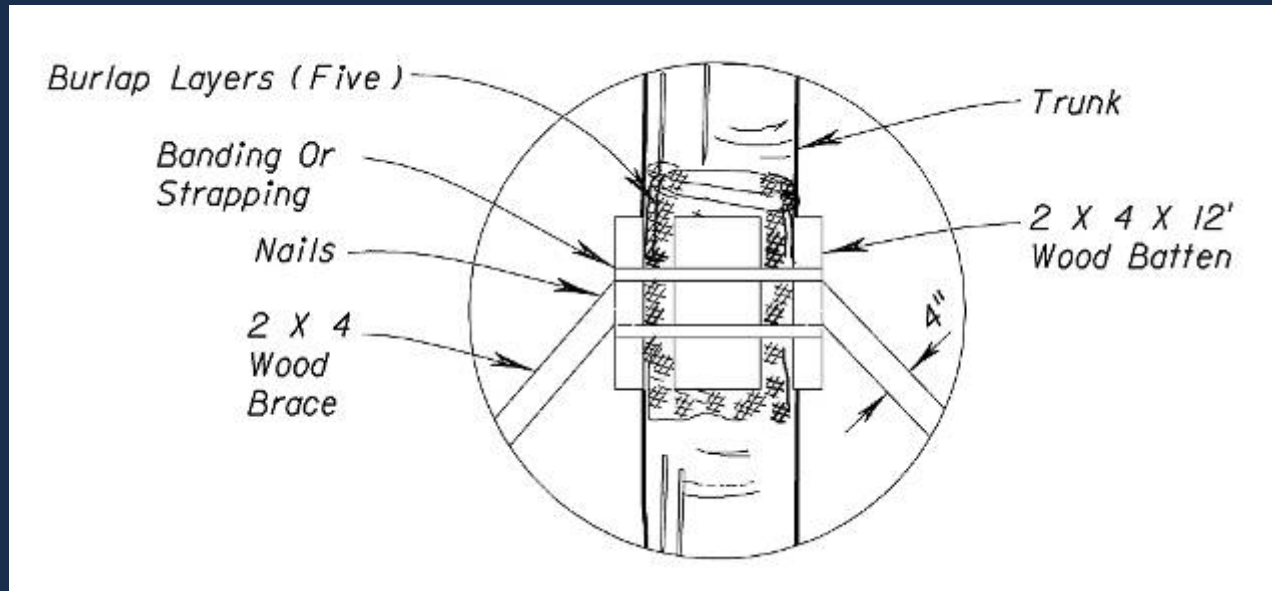

- ◆ Trunk should be wrapped in at least five layers of burlap, to prevent surface scraping.
- ◆ Note the orientation of 2 x 4 wooden brace (wider side vertical), for maximum strength.
- ◆ Wooden braces should be saw-cut to allow for flush connection to the wooden batten. This angle varies depending on distance from the trunk to earth anchors and height of wooden batten from soil level.

# Index 544: Palm Planting.

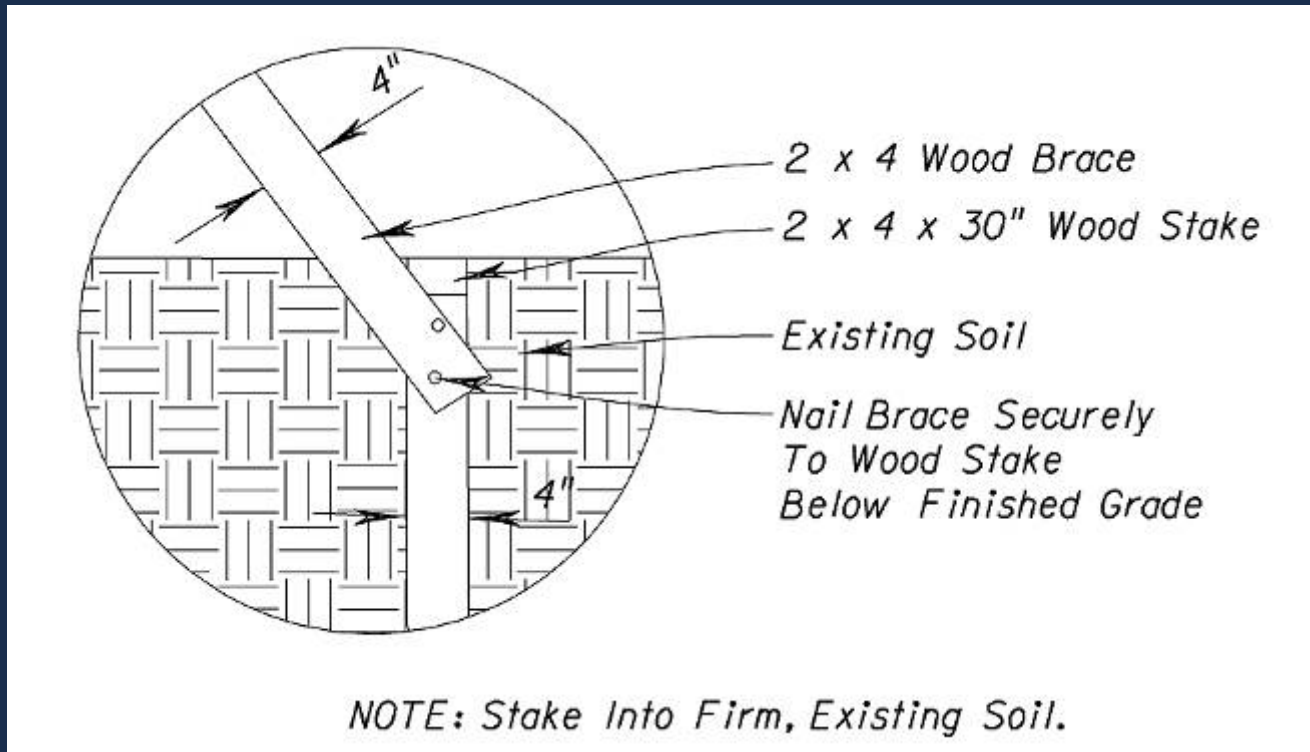

- ◆ This diagram illustrates the connection of wooden braces to wooden stakes (earth anchors). Again, note vertical orientation of the 2 x 4 braces and stakes.
- ◆ Stakes should be driven below soil level, into firm native soil.

# Index 544: Shrub Planting.

- ◆ Shrub planting is similar to tree planting as follows:
  - ◆ Planting pit should be at least 2x the diameter of rootball and only as deep as the depth of rootball.
  - ◆ Only existing soil should be used as backfill.
- ◆ Shrub planting is different from tree planting as follows:
  - ◆ No staking or guying is necessary.
  - ◆ When planting on flat ground, no soil ring is necessary.
  - ◆ Entire planting bed should be mulched.

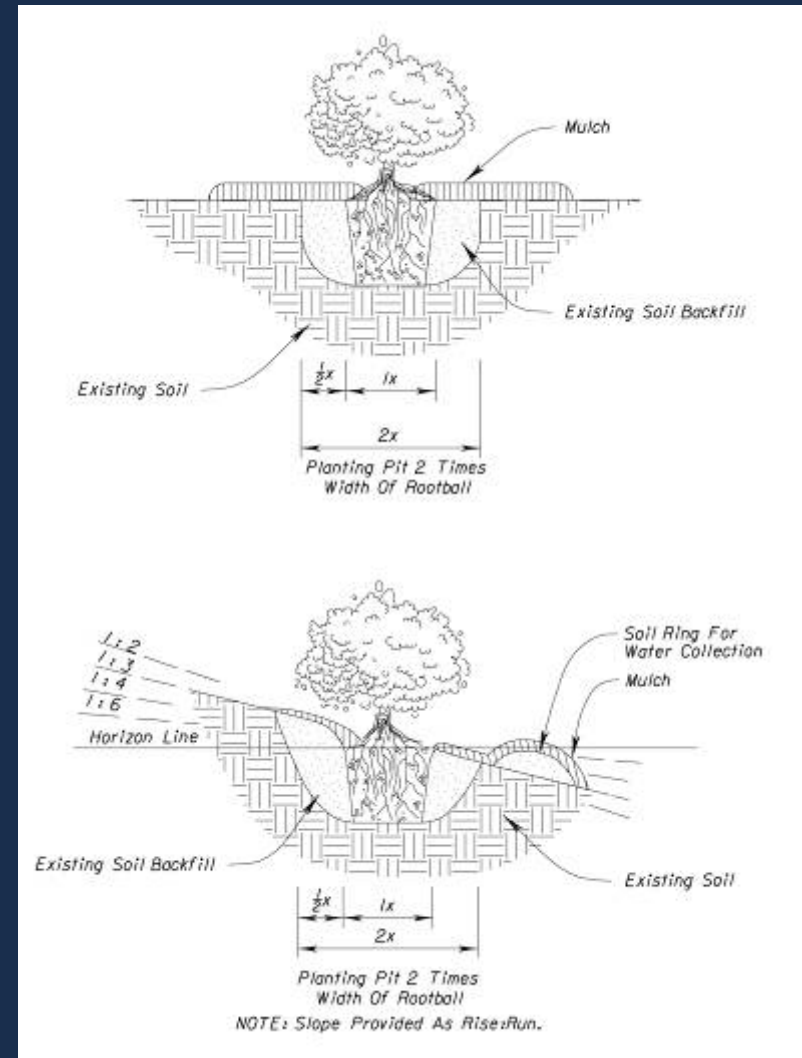

# Index 544: Shrub Planting.

## Shrub layout:

- ◆ In multiple-plant beds or double rows, stagger plants to provide more growing space and avoid empty spots.
- ◆ Planting beds should be mulched to the edge of the crown spread. Weeds (and turfgrass) should be removed periodically from the planting bed.

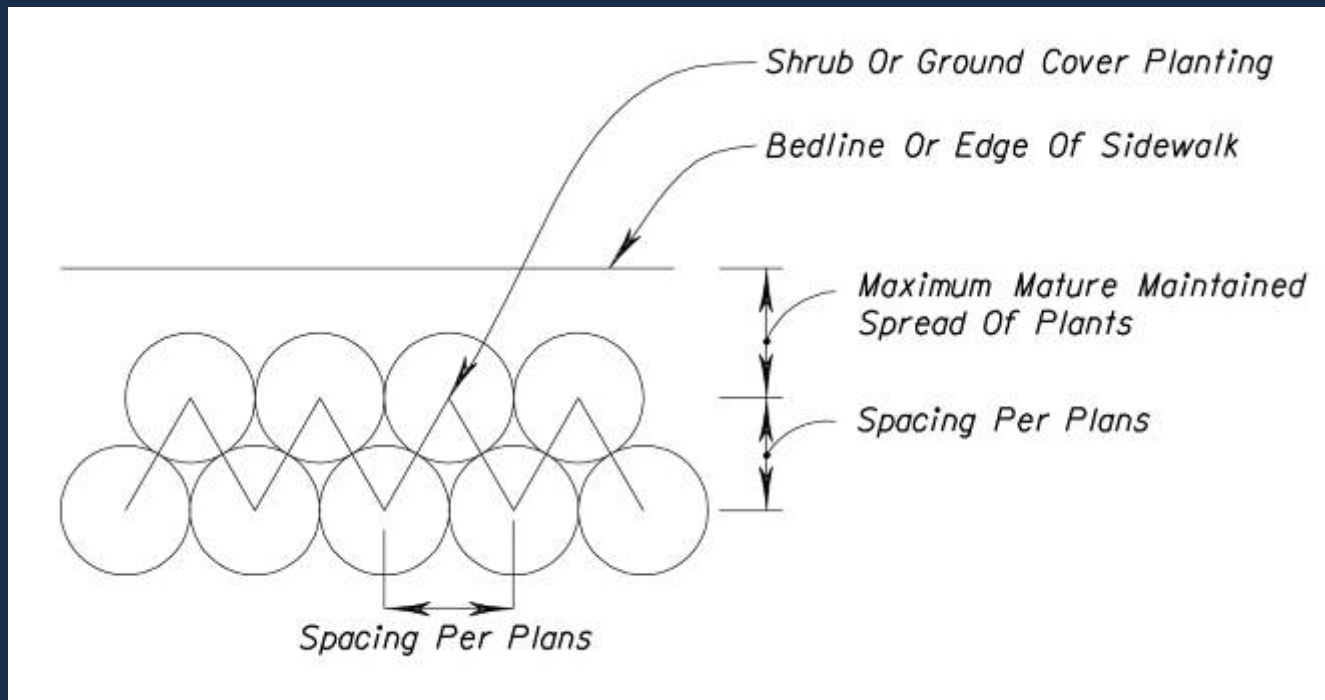

# Index 544: Tree Protection.

- ◆ Critical protection zone: the area surrounding the tree within the circle described by a radius of one foot for each inch of the tree trunk diameter at 54" above finished grade.
- ◆ Individual trees: surround entire critical protection zone with barricade.
- ◆ Tree groups: place barricade between trees and construction activity.

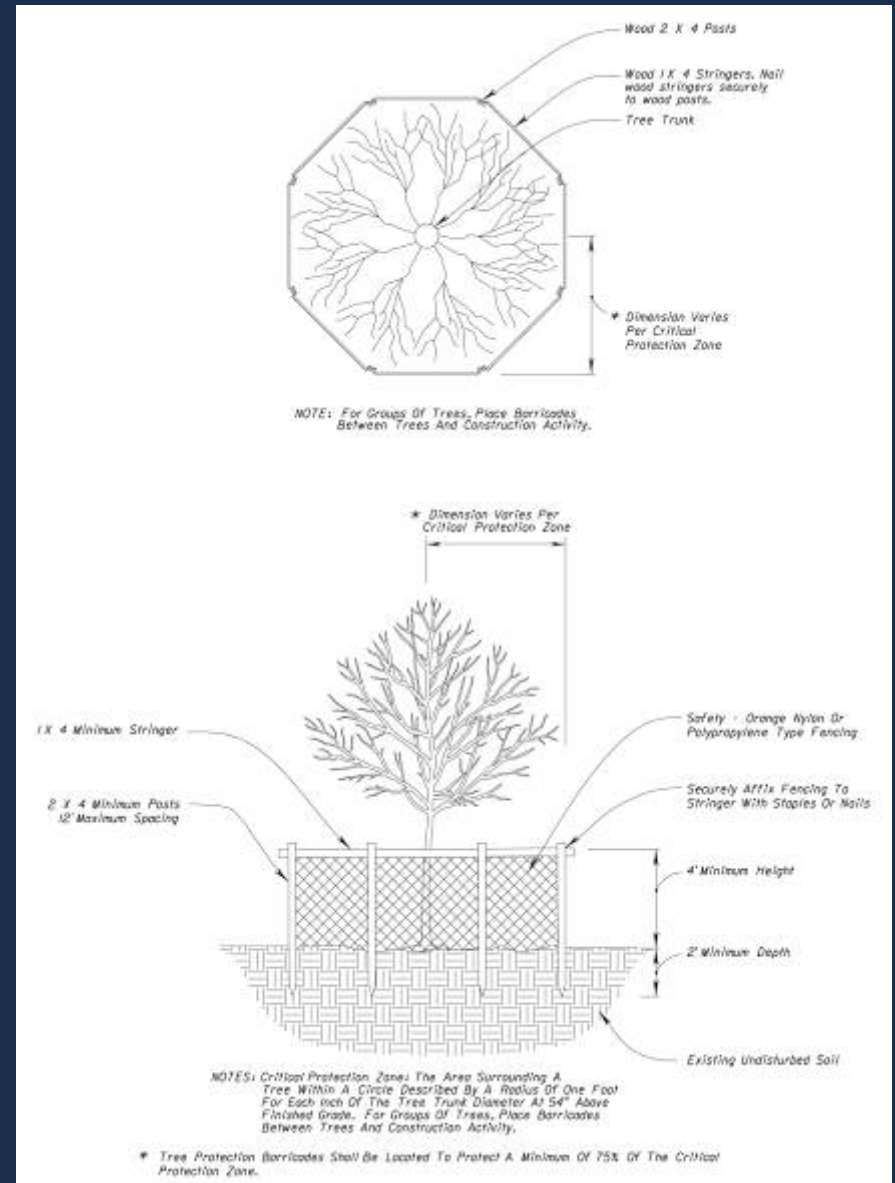

# Irrigation

All plants should be watered immediately upon planting. Waiting until the end of the day to water all plants at once is detrimental to root growth and plant health, and is not acceptable.

If irrigation system is not provided, plants should be watered regularly and deeply using a water truck. Frequency of watering should be based on weather, soil type, and plant species. When watering large shrubs and trees, enough water should be applied to moisten soil throughout the root growth zone. Frequent light applications of water that moisten only the top few inches of soil cause majority of new root growth to be located in the upper layer of soil. Such plants are not prepared to rely on rain once the regular watering stops – they simply do not have a deep root system necessary to draw water from deep soil layers.

# Irrigation

If irrigation system is provided, it should be checked to assure that all components function properly, and that 100% (or “head-to-head”) coverage is achieved.

“Head-to-head” coverage literally means that spray from one sprinkler should reach its neighboring sprinklers. The diagram on right illustrates this principle.

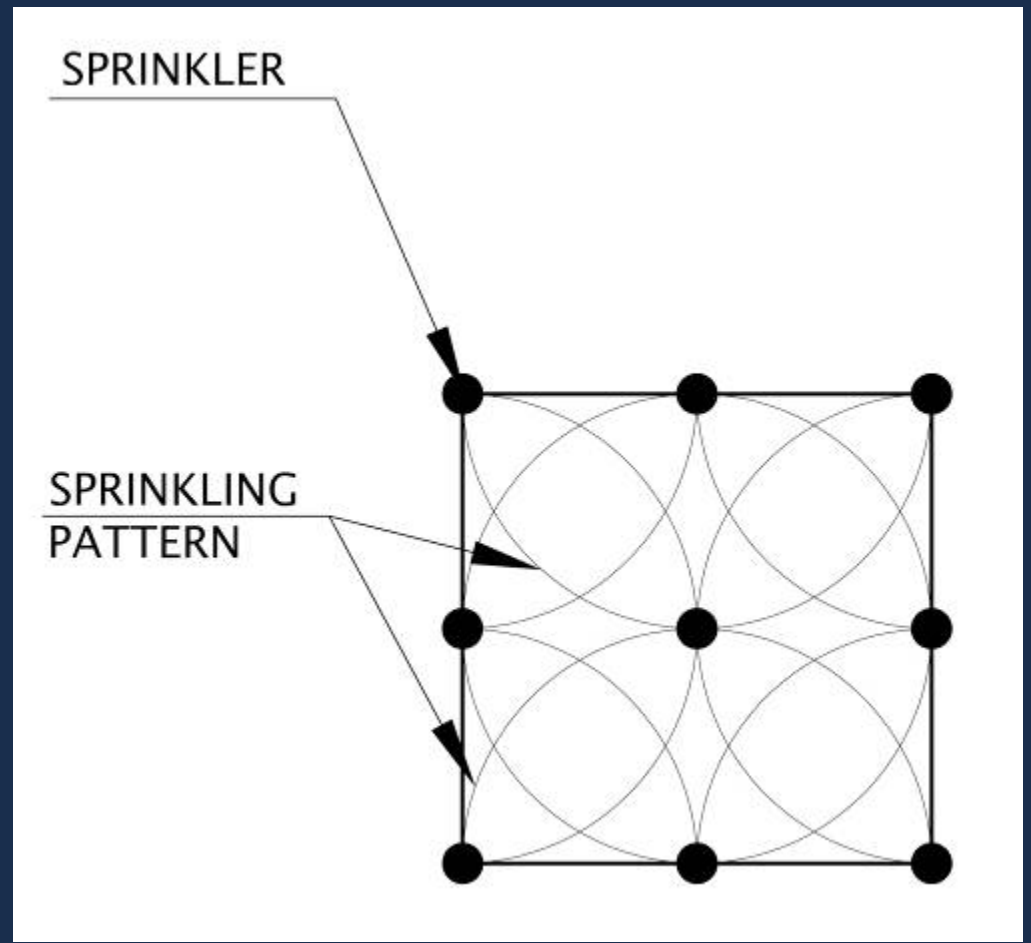



# Irrigation - Checklist

The following checklist (although not all-inclusive) could be used to verify proper functioning of the irrigation system:

- ◆ Make sure an irrigation system is equipped with a rain sensor that automatically stops the sprinkler system during a rain event – it's the law!
- ◆ Contractor should flush the system before first use.
- ◆ Replace/adjust broken or leaning sprinkler heads.
- ◆ Avoid overspray (irrigation of sidewalks or roads).
- ◆ Rotors not rotating.
- ◆ Misting instead of spraying water droplets (indicates that water pressure is too high).

## Irrigation – cont.

- ◆ Uneven coverage – this should be measured by randomly placing clear cups throughout the irrigated area, running the system for at least 30 minutes, then measuring depth of water in each cup (depths should be approximately equal).
- ◆ Plant material should not block spray patterns (and create dry spots).
- ◆ Check for clogged nozzles, leaking lines, or missing components.
- ◆ Check operation of the automatic irrigation timer. Review irrigation schedule and timing. It is best to apply water early in the morning, to reduce evaporation losses and disease occurrence.

# Transplant Shock

Contractor is required to maintain plantings in healthy condition until establishment, which requires adequate fertilization, irrigation and care. Negligence in any one aspect of landscape maintenance of newly transplanted plants may result in transplant shock, or adverse impact on plant overall health and the length of establishment period.

Learn to recognize the following signs of transplant shock, water stress and injury:

- ◆ Wilt.
- ◆ Leaf scorch.
- ◆ Nutrient deficiencies.
- ◆ Herbicide injury.

# Wilt

Wilt refers to loss of rigidity (turgor) and drooping of leaves generally caused by insufficient water in the plant. This condition can be caused by transplant shock, but also by drought, and vascular infection by a fungus or bacterium.

Wilting caused by Dutch Elm Disease.



# Leaf Scorch

Leaf scorch symptoms are browning of leaf margins (blackening in some species), that progresses inward between the major leaf veins. The cause of this problem is inability of the root system to supply enough water to the leaves.

Besides transplant shock, bacterial diseases of xylem (inner part of the trunk) and roots, high winds, or other causes that restrict water supply to the foliage, will result in leaf scorch. That's why scorch symptoms are often more severe on outer, more exposed leaves, especially on sunward or windward side of the tree.



Image property of Purdue University Extension Service (<http://www.ces.purdue.edu>)



Image property of KSU Research & Extension Used with permission (Professor Charles Marr)

# Nutrient Deficiency

Trees need certain nutrients for proper growth. Nitrogen, phosphorus and potassium (N-P-K) are the most important. Many other major and minor nutrients are essential to tree growth. Symptoms of nutrient deficiency mimic many other diseases and vary greatly depending upon which nutrient is lacking. The most common symptoms of nutrient deficiency are: reduced growth, leaf chlorosis, yellowing, and necrosis.



Photograph property of USDA Forest Service  
(<http://www.na.fs.fed.us>)

# Herbicide Injury

Improperly applied herbicides can injure trees. Leaves of deciduous trees will become distorted, curled, and brown on the margins (similar to scorch). Conifer needles will turn yellow or brown, and succulent shoots will curl or become deformed. Trees will usually survive, but their growth will be stunted.



Photograph property of University of Nebraska-Lincoln  
(<http://www.ianrpubs.unl.edu>)

# Turf

Turf is very important in roadway installations, and not only in terms of aesthetics:

- ◆ Dense, vigorous turf stand protects soil surface from erosion.
- ◆ Established turf on roadway shoulders protects the edge of pavement.
- ◆ A healthy turf stand filters roadway runoff and prevents non-point pollution.

The key to achieving these benefits is providing a vigorously growing stand of turf. Just like tree and shrub planting, turf installation and maintenance has to use proper methods in order to assure turf survival and establishment.



# Turf – Acceptance Criteria

Turf can be installed by seeding or sodding. Regardless of installation method, final acceptance of turf is based on the following criteria, described in Standard Specifications:

- ◆ Established root system (leaf blades break before seedlings or sod can be pulled from the soil by hand).
- ◆ No bare spots larger than one square foot [0.1m<sup>2</sup>].
- ◆ No continuous streaks running in the direction of water runoff.
- ◆ No bare areas comprising more than 1% of any given 1,000 square foot [100 m<sup>2</sup>] area.
- ◆ No deformation of the turf areas caused by mowing or other Contractor equipment.

# Turf – Acceptance Criteria

In turf installation, watch out for the following hazards:

- ◆ Turf surface is more than 1" above or below the sidewalk surface. This usually happens when the depth of turf was not accounted for in soil grading. Such conditions may create trip hazards.
- ◆ Exposed netting.
- ◆ Stakes (in slope installations) protruding above ground surface.

# Turf - Mowing

Improper mowing causes more problems with turf than any other maintenance practice:

- ◆ Mowing too low may cause scalping. Scalping in patches is an indication of a poor grading job done prior to turf installation.
- ◆ Mowing too low on a regular basis results in a less developed root system, and susceptibility of turf to drought. FDOT specifies that grass should not be mowed lower than 6".
- ◆ If mower blades are not sharpened regularly, the grass blade is shredded and is more likely to be infected by pathogens.
- ◆ Mowing in the same direction each time may result in noticeable patterns on turf. The grass actually leans in the direction of mowing.
- ◆ Trash should be picked up before each mowing, otherwise it may become a hazard, when thrown by mower blades.

# Turf - Injury

One of the examples of turf deformation or injury is scalping – browning of turf that results from too low cutting height or cutting on uneven surface. This process is sometimes used to renovate old bermuda turf, but it should never be used on a newly installed turf.



The turfgrass on the left is brown during the active growing season due to scalping.

Image property of Dr. L.B. McCarty, used with permission.  
<http://turf.ufl.edu>

# Turf - Injury

Other injuries to turf may include herbicide injury, evidence of pest or disease problems, fertilizer burn, and localized dry spots.



The photograph on the left illustrates one of the symptoms of herbicide injury. Other symptoms may include chlorosis, stunted and irregular growth and dry, dead leaves.

Image property of Dr. L.B. McCarty, used with permission.

<http://turf.ufl.edu>

# Turf - Weeds

Turf should be free from undesirable vegetation, which may include invasive species or tree seedlings. In a pure stand of grass this is easy to see, but becomes difficult if the turf includes more than one species of grass, or wildflowers.



Image property of University of California.

Examples of some of the most common Florida weeds, spurge (left) and crabgrass.

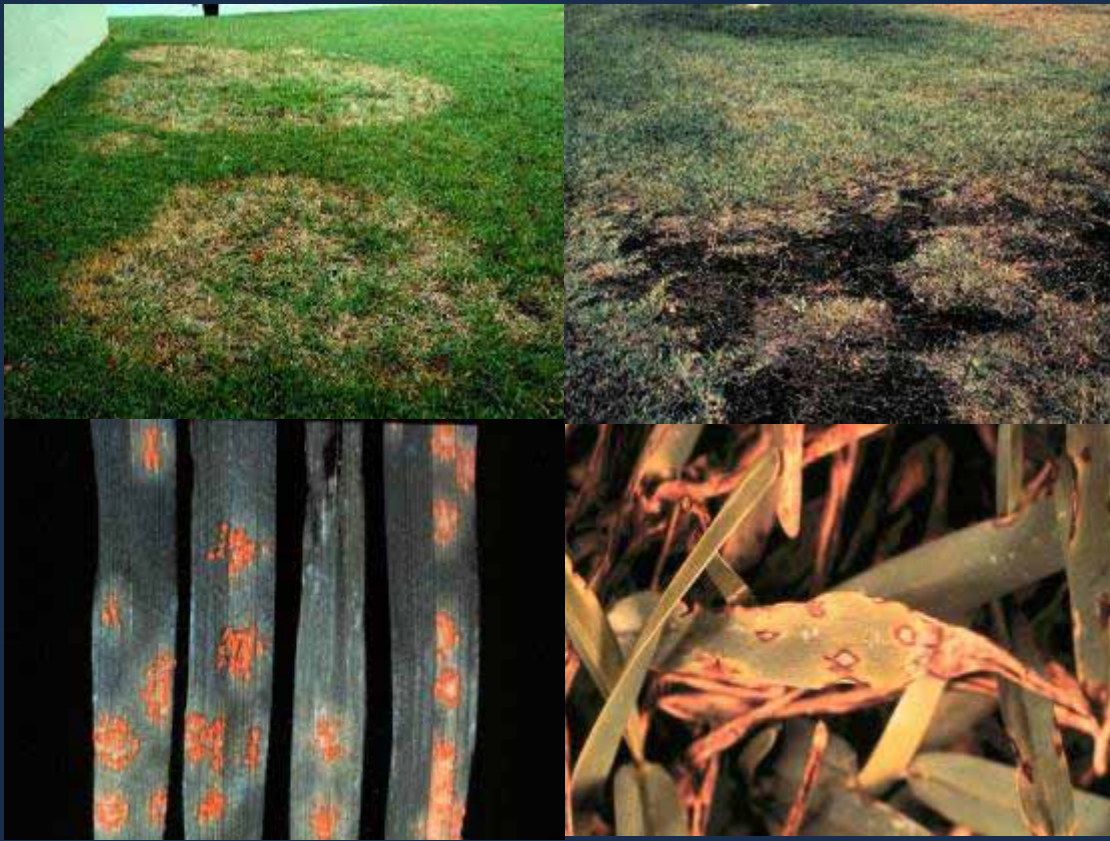

Image property of Dr. L.B. McCarty, used with permission.

<http://turf.ufl.edu>

# Turf - Disease Symptoms

Symptoms of disease damage may include patches or areas of yellow, brownish, or dead turf, orange or black spots on leaves, slimy decay, or chlorosis associated with general decline.



Examples of some of the most common Florida diseases (clockwise from top left): brown spot, take-all root rot, grey spot, and rust.

Images property of Dr. M.L. Elliott and Dr. G.W. Simone.

University of Florida, IFAS Extension. Used with permission.

<http://turf.ufl.edu>

# Glossary

- ◆ **Balled and Burlapped (B & B):** Field-grown trees, harvested and packaged with a soil ball containing roots of the plant wrapped and secured in synthetic, natural or treated burlap, and/or wire.
- ◆ **Boot:** In palms - the dead leaf base or enlarged portion of the petiole remaining affixed to the trunk after the leaf has died, been broken, or cut off.
- ◆ **Caliper:** Trunk diameter measured 6 inches from the ground on trees up to and including 4 inches in caliper, and 12 inches above the ground for larger trees.  
In palms - the diameter of the palm trunk taken at the widest portion, measured between 1 foot and 3 feet from the soil line.
- ◆ **Dominant Leader:** The single trunk that grows up through the center of the tree and obviously dominates the rest of the branches.
- ◆ **Chlorosis:** Yellowing of leaves due to low chlorophyll levels. Chlorosis may be caused by nutrient deficiencies, low light conditions and plant diseases. Chlorosis is not to be confused with normal yellowing of foliage common on many deciduous species late in the season. It is also not to be confused with yellowing of leaves on evergreens just prior to a new leaf flush.



# Glossary

- ◆ **Clear trunk:** An industry term referring to that portion of the trunk maintained free of any branches. The clear trunk is the lower portion of the trunk measured from the soil line up to the first major branch. Temporary branches may exist on a clear trunk.  
In palms - a measurement from the soil line to a point in the canopy where the trunk caliper begins to taper abruptly. On many palms, this point will lie at the base of the petiole of the third or fourth youngest but fully expanded leaf.
- ◆ **Clustering Palms:** Palms with two or more trunks (suckers) growing in a single group.
- ◆ **Conifer:** A class of trees that are evergreen, have needle or scale-like foliage and cone-like fruit; often called softwood. Examples include pine, hemlock, cedar and cypress
- ◆ **Corrective pruning:** Pruning which removes one or more branches or trunks to create a stronger, well structured tree framework.
- ◆ **Crown:** The branches, twigs and leaves that make up the foliage portion of the tree.
- ◆ **Crown spread:** Crown spread diameter is the average of the widest branch spread and that perpendicular to it.

# Glossary

- ◆ **Crownshaft:** In palms - a conspicuous neck-like structure formed by tubular leaf bases on some palms with pinnately compound leaves.
- ◆ **Dominant Branch:** One of the larger branches comprising the main structure of tree crown.
- ◆ **Extreme succulence:** In palms - soft, tender growth caused by over-fertilization, over-irrigation or overcrowding. The palm may not survive when transplanted.
- ◆ **Flush cut:** A pruning cut made too close to, or flush with, the trunk.
- ◆ **Foliage:** Tree leaves, collectively.
- ◆ **Girdling root:** root growing around part of the trunk, restricting its expansion.
- ◆ **Grade:** A level of plant quality that meets minimum standards.
- ◆ **Included (embedded) bark:** Bark between a narrow angle of branch attachment and trunk or between trunks that is squeezed together in the crotch of the branch. This condition indicates weak attachment and branch could easily break off from the trunk as the tree grows older.
- ◆ **Intermediate trunk (in cluster type palms):** Clear trunk height half or more as tall as the main trunk or trunks.

# Glossary

- ◆ **Leader:** That part of the trunk that extends into the top 1/4 of the tree.
- ◆ **Main trunk(s)** (in cluster type palms): Tallest trunk in the cluster. All other trunks at least three fourths of this height will be considered main trunks.
- ◆ **Major branch:** A branch that is among the largest in diameter on the tree.
- ◆ **Matrix:** A set of data (numbers) arranged in a rectangular array (rows and columns)
- ◆ **Mature height:** In palms - the height range at which the species begins to exhibit mature trunk characteristics, and the minimum height at which caliper shall be considered in Grading.
- ◆ **Midrib:** Central vein of a leaf or leaflet.
- ◆ **Multiple leaders:** Two or more trunks growing nearly parallel to each other, originating at any place along the stem. The crotch angle between them is often very narrow. This tree defect is more serious when it occurs on the lower portion of the tree.
- ◆ **Nearly-equal diameter:** One trunk or branch is at least 2/3 the diameter of the other.

# Glossary

- ◆ **Palmate Leaf:** Leaf with leaflets radiating from one point, like fingers from a palm of a hand.
- ◆ **Pinnate Leaf:** Leaf with leaflets arranged in rows on both sides of a central midrib, featherlike in appearance.
- ◆ **Root-ball diameter:** The average diameter of the widest portion of the root ball and that perpendicular to it, measured near the top of the root ball.
- ◆ **Root bound:** A condition of container grown trees where there are several roots larger than 1/4 inch diameter growing on the outside edge of the root ball.
- ◆ **Suckers (in cluster type palms):** Any stem which does not meet the height specifications of an intermediate or main trunk.
- ◆ **Temporary branches:** Short branches meant to be pruned from the tree in the near future as the tree grows and produces major branches.
- ◆ **Terminal Bud:** End bud of the leader.
- ◆ **Topiary:** A formal, man-manipulated plant form, either tree or shrub, developed and maintained by frequent clipping and shearing.

# Glossary

- ◆ **Transplant Shock:** Stress caused by transplanting, leading to wilting, leaf drop, die-back, and possibly plant death.
- ◆ **Tree height:** Tree height is measured from the ground to the topmost portion of the tree.
- ◆ **Trunk dogleg:** A significant 's' - shaped deformation in the trunk.
- ◆ **Trunk wound:** A trunk injury that is open and not sealed over, or closed. A properly executed pruning cut that is not closed over is not considered a trunk wound.
- ◆ **Turgor:** Normal rigid state of fullness of a plant cell resulting from pressure of the contents against the cell wall.
- ◆ **Wilt:** Loss of turgor (cell rigidity) caused by lack of water in the plant cells.

# References and Links

1. Atlas of Florida Vascular Plants: <http://www.plantatlas.usf.edu/>
2. Construction Project Administration Manual  
<http://www.dot.state.fl.us/construction/manuals/cpam/CPAM70000000/cpamman.htm>
3. Division of Plant Industry Bureau of Plant and Apiary Inspection requirements for nursery registration and certification  
<http://www.doac.state.fl.us/pi/>
4. EDIS IFAS <http://turf.ufl.edu>.
5. Florida Grades and Standards for Nursery Stock  
<http://www.doacs.state.fl.us/pi/plantinsp/publications.html>
6. Florida Highway Landscape Guide  
<http://www.dot.state.fl.us/emo/beauty/landscap.pdf>
7. Florida Greenbook  
<http://www.dot.state.fl.us/rddesign/FloridaGreenbook/FGB.htm>
8. Floridata – Encyclopedia of Plants and Nature:  
<http://www.floridata.com/>

# References and Links

9. FY QC Category No. 14B Statewide Inspection List for Landscaping  
<http://www.dot.state.fl.us/construction/CONSTADM/guidelist/guideindex.htm>
10. Horticipia: <http://www.horticipia.com>
11. Roadway and Traffic Design Standards [http://www.dot.state.fl.us/rddesign/rd/RTDS/Standard\\_Index.htm](http://www.dot.state.fl.us/rddesign/rd/RTDS/Standard_Index.htm)
12. Standard Specifications for Road and Bridge Construction  
<http://www.dot.state.fl.us/specificationsoffice/2004BK/toc.htm>
13. Tree Grading Cue Card by visiting [www.rootsplusgrowers.com](http://www.rootsplusgrowers.com)
14. USDA PLANTS Database: <http://plants.usda.gov/>
15. Utility Accomodation Manual  
[http://www.dot.state.fl.us/rddesign/utilities/files/UAM\\_04.htm](http://www.dot.state.fl.us/rddesign/utilities/files/UAM_04.htm)